



US00D441321S

(12) **United States Design Patent** (10) **Patent No.:** **US D441,321 S**
Faurote et al. (45) **Date of Patent:** **** May 1, 2001**

(54) **VEHICLE BODY**

DESCRIPTION

(75) Inventors: **Brandon L. Faurote**, Rochester;
Donald A. Renkert, Royal Oak; **David C. McKinnon**, Birmingham; **Robert E. Boniface**, Bloomfield Hills, all of MI (US)

FIG. 1 is a perspective view of the front and left side of a vehicle body showing our new design;

FIG. 2 is a perspective view of the rear and right side thereof;

(73) Assignee: **DaimlerChrysler Corporation**, Auburn Hills, MI (US)

FIG. 3 is a left side view thereof, it being understood that the opposite side not shown is a substantial mirror image thereof;

(**) Term: **14 Years**

FIG. 4 is a front view thereof;

(21) Appl. No.: **29/116,169**

FIG. 5 is a rear view thereof;

(22) Filed: **Dec. 28, 1999**

FIG. 6 is a left side view of a vehicle body showing a second embodiment of our new design, the differences from the first embodiment being the incorporation of an alternative body side molding and an alternative front fascia, it being understood that the opposite side to that shown is a substantial mirror image thereof;

(51) **LOC (7) Cl.** **12-08**

(52) **U.S. Cl.** **D12/91**

(58) **Field of Search** D12/90-92; 296/185

(56) **References Cited**

U.S. PATENT DOCUMENTS

D. 360,606	7/1995	Holmes et al.	12/90
D. 414,134	* 9/1999	Ikeda	D12/91
D. 418,087	* 12/1999	Ueno	D12/91
D. 424,980	* 5/2000	Hunter et al.	D12/91
D. 425,584	* 7/2000	Warkuss	D12/91

* cited by examiner

FIG. 7 is a front view of the vehicle body of the fourth embodiment; and,

FIG. 8 is a rear view of the vehicle body of the fourth embodiment.

The roof of all embodiments of the vehicle body is understood to be plain and unornamented. It is further being understood that the hidden line showing throughout the drawings is for illustrative purposes only and forms no part of the present invention.

It will be further understood that the top is plain and unornamented.

Primary Examiner—Melody N. Brown
(74) *Attorney, Agent, or Firm*—Mark P. Calcaterra

(57) **CLAIM**

The ornamental design for a vehicle body, as shown and described.

1 Claim, 6 Drawing Sheets

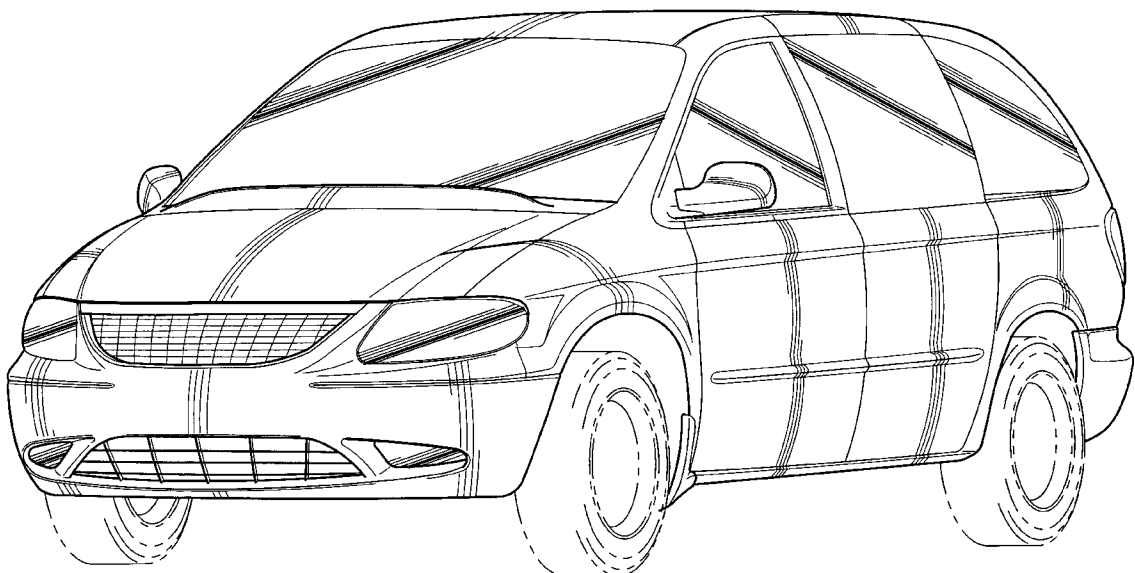

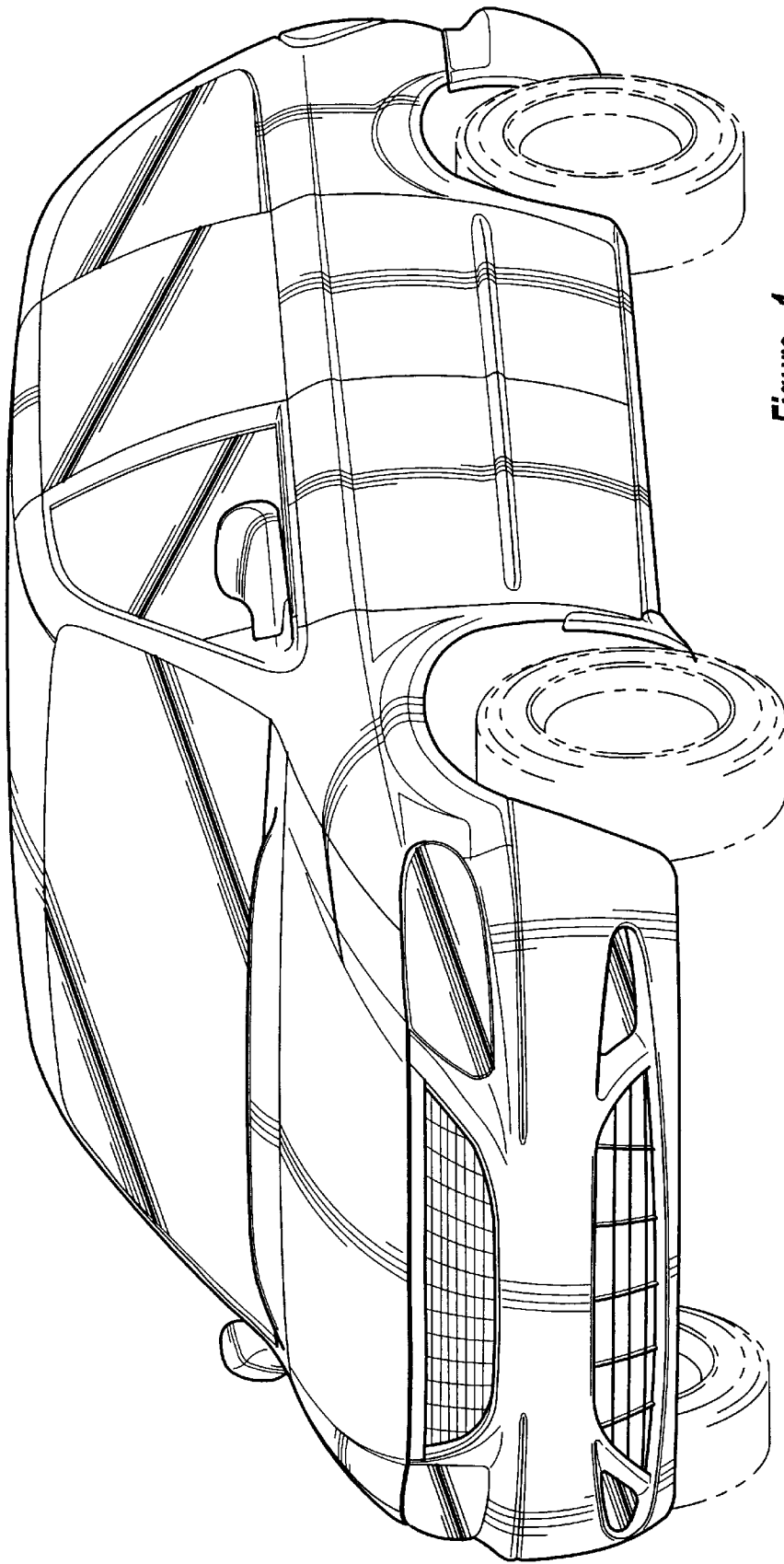

Figure - 1

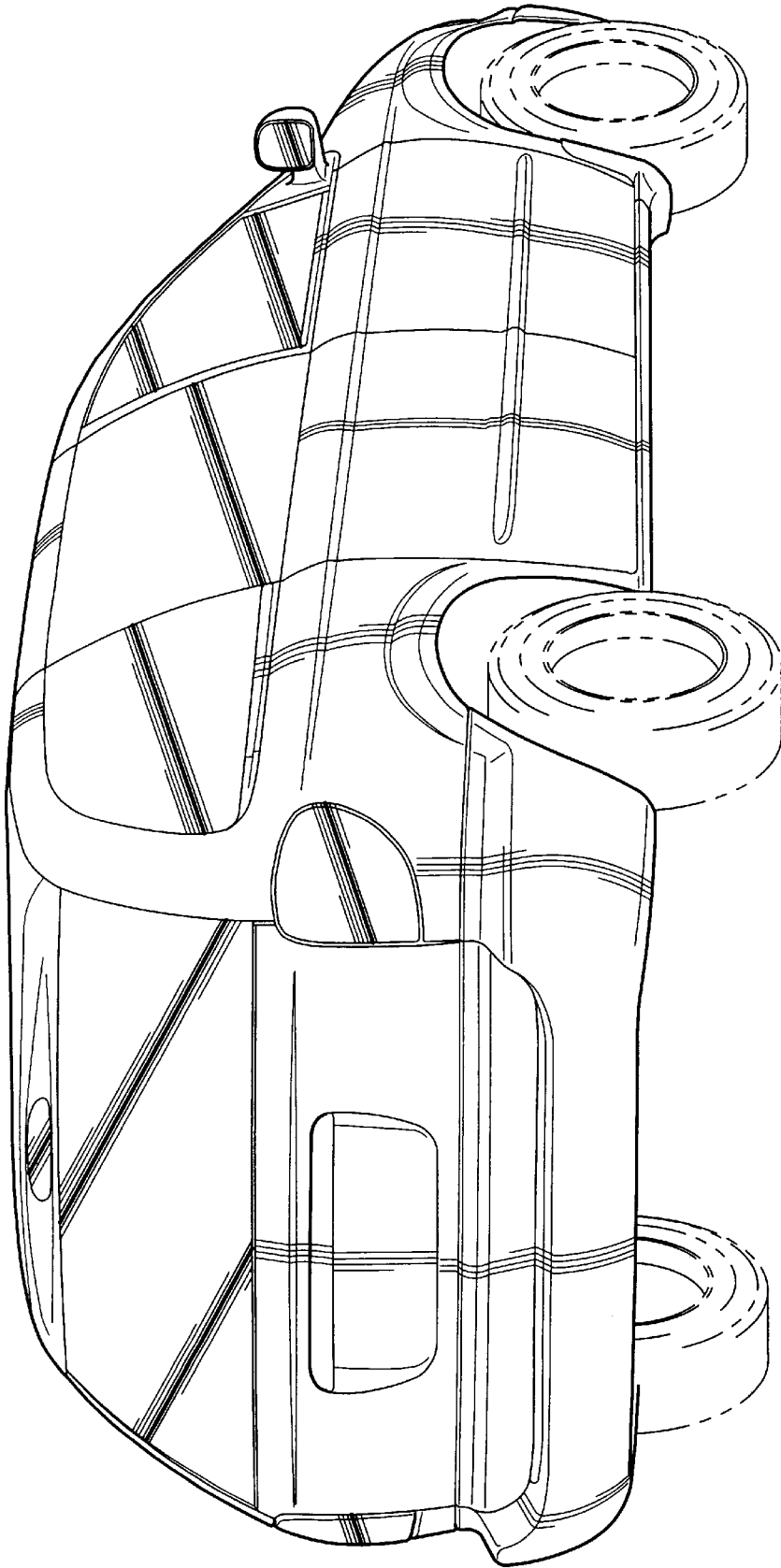

Figure - 2

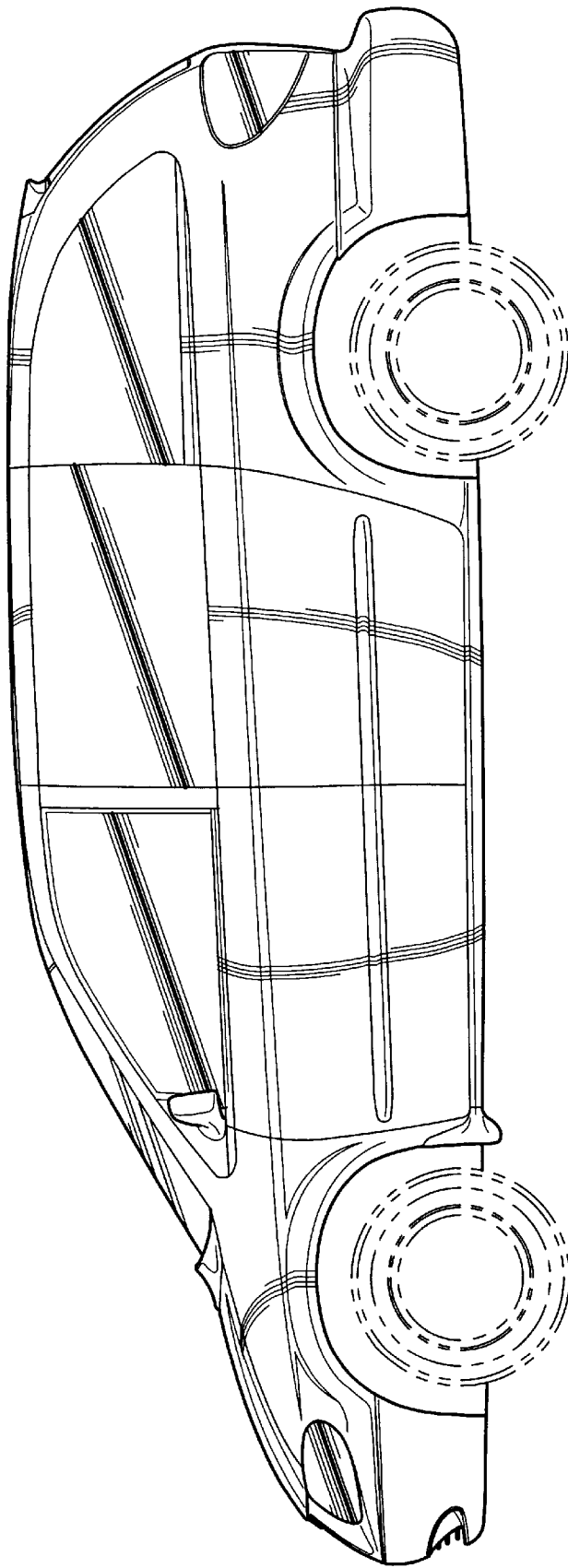

Figure - 3

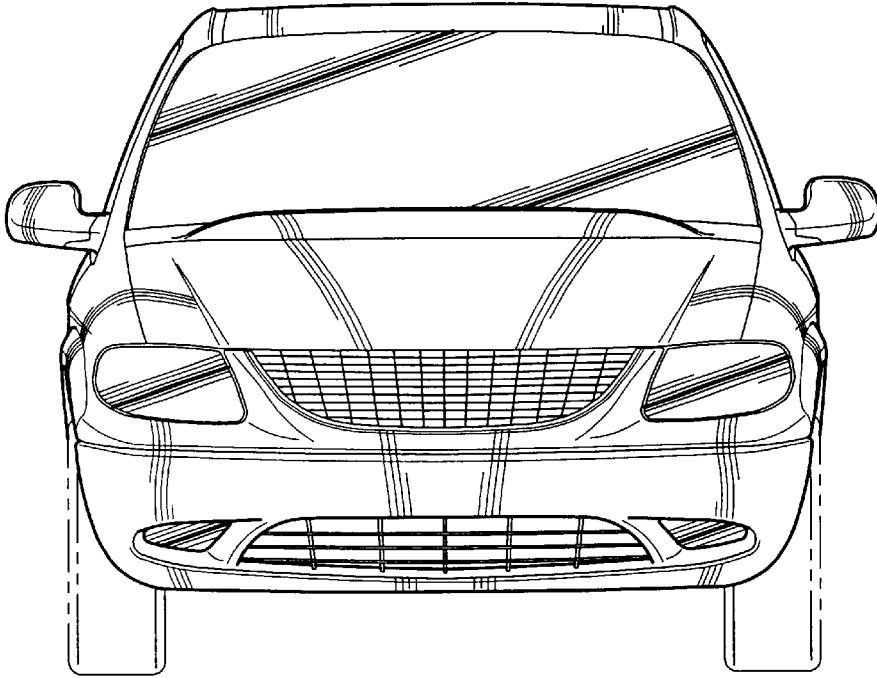

Figure - 4

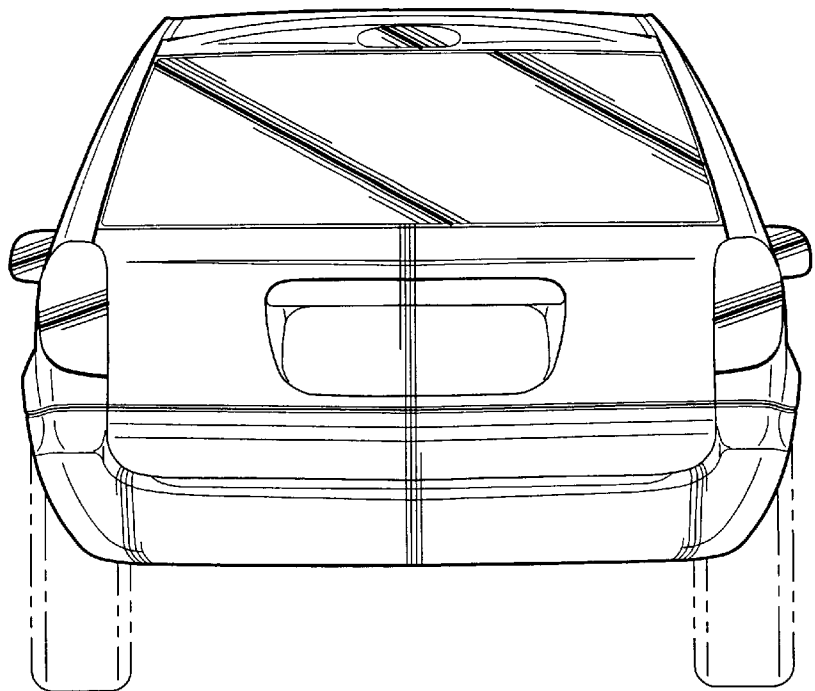

Figure - 5

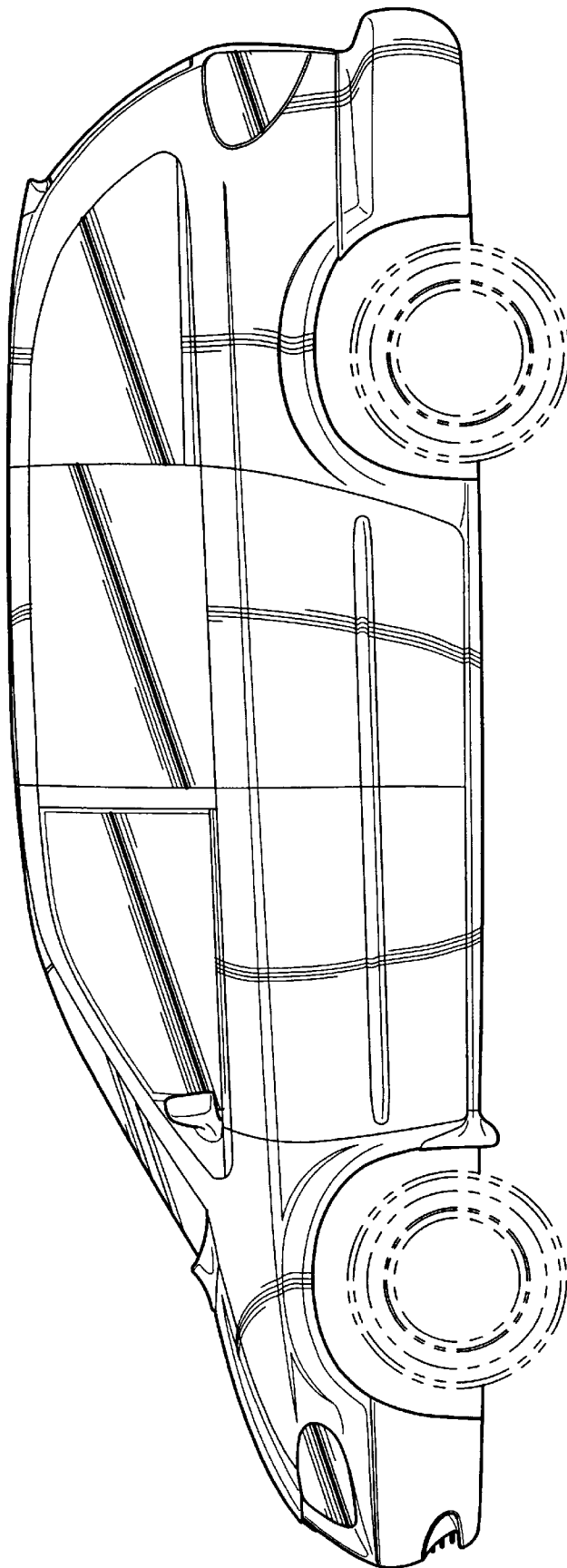

Figure - 6

Figure - 7

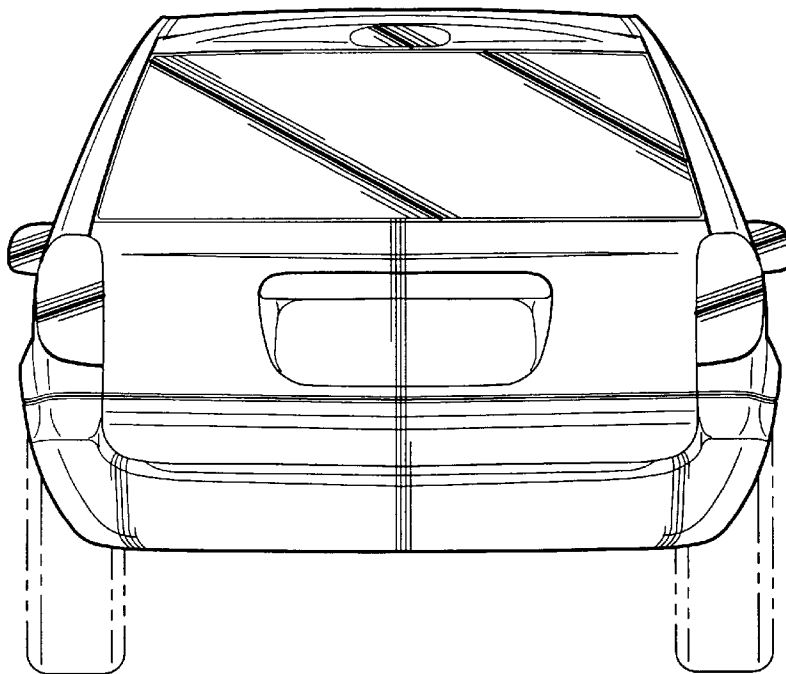
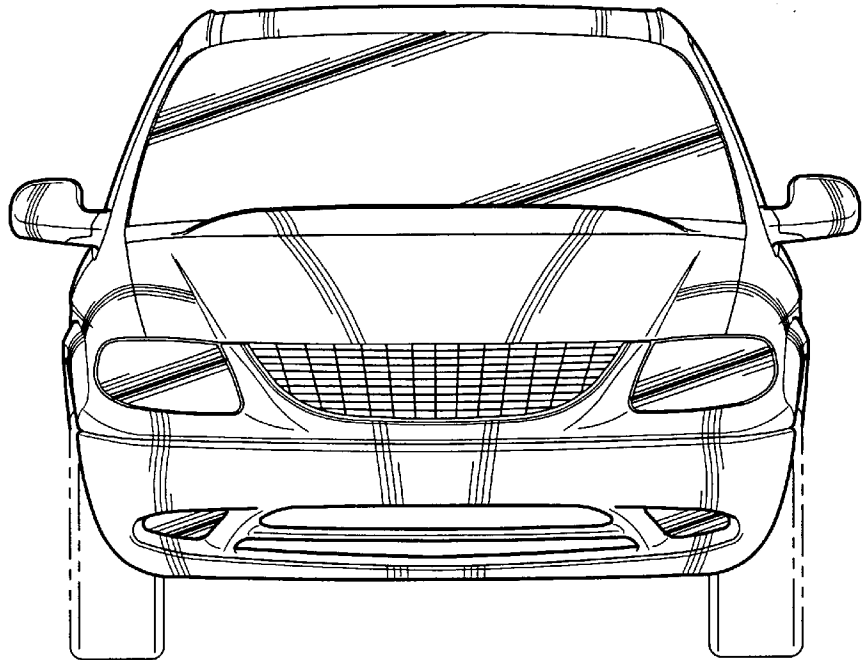

Figure - 8