

(No Model.)

A. H. JARECKI.  
SAFETY VALVE.

No. 287,131.

Patented Oct. 23, 1883.

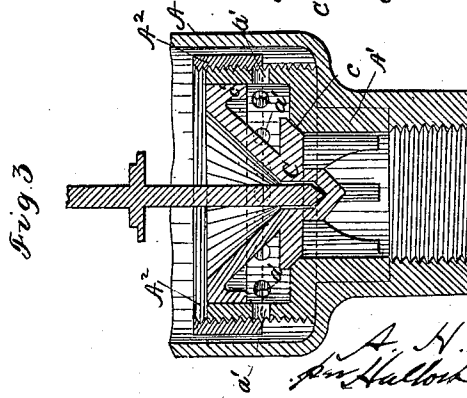
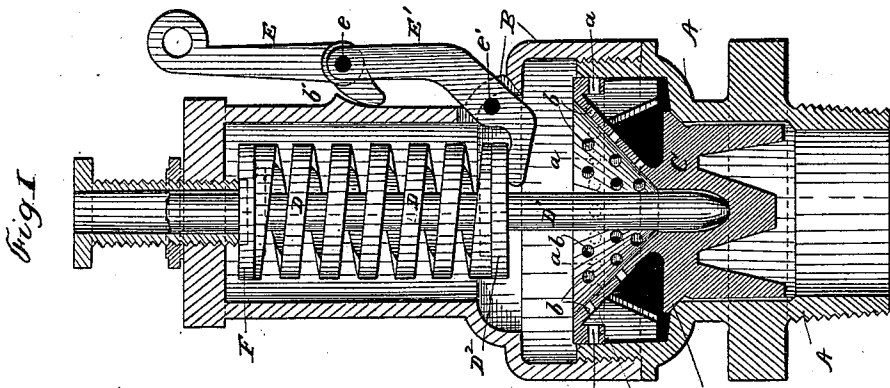
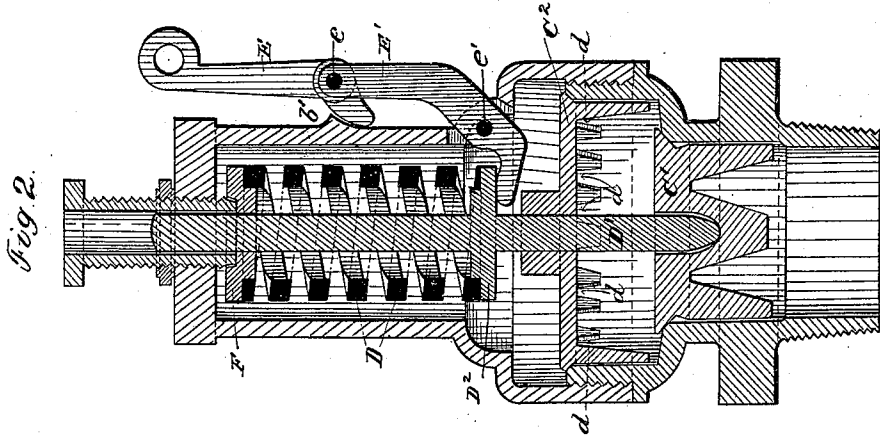

Witnesses  
W. R. Edelin  
Robt. H. Porter.

Inventor

A. H. Jarecki  
per Hallock & Hall

# UNITED STATES PATENT OFFICE.

ALBERT H. JARECKI, OF ERIE, PENNSYLVANIA.

## SAFETY-VALVE.

SPECIFICATION forming part of Letters Patent No. 287,131, dated October 23, 1883.

Application filed June 15, 1883. (No model.)

*To all whom it may concern:*

Be it known that I, ALBERT H. JARECKI, a citizen of the United States, residing at Erie, in the county of Erie and State of Pennsylvania, have invented certain new and useful Improvements in Safety-Valves; and I do hereby declare the following to be a full, clear, and exact description of the invention, such as will enable others skilled in the art to which it appertains to make and use the same.

This invention relates to safety-valves; and it consists in providing new and useful improvements in the construction of the valves of said device, as will fully and at length appear in the following description and claims.

A second feature of the invention relates to devices for opening the valve by hand.

The first feature in the construction of the valve consists in making the upper seating of a differential valve in the form of a cylinder and piston, the piston being adapted to be lifted above the cylinder when a wide escape for steam is required.

This second feature of the valve consists in providing the said piston with openings through it, so that a partial escape of steam can be had before the piston is lifted wholly out of the cylinder.

The third feature of the valve consists in the form which may be given to the said openings through the piston, whereby they will afford more and more opening the higher the valve rises.

The improvement in the means for springing the valve by hand consists in the combination and arrangement of a compound leverage, whereby less exertion is required to raise the valve.

The invention is illustrated in the drawings by three figures, all of which are vertical sectional views. The construction is somewhat varied in each figure, for the purpose of showing variety in the manner of applying the invention.

In Figures 1 and 3 the differential valves are shown as solid—*i. e.*, made of one piece of metal—while in Fig. 2 is shown a valve composed of two parts,  $C^1 C^2$ ; but it will be seen that in all cases the upper part is shown as a narrow piston working in a cylinder. In Fig. 3 the piston

is not provided with openings at all; but the cylinder is, (see  $a'$ ), and a hooding-ring,  $A^2$ , is used to regulate the size of the openings, and so fix the degree of pressure which will be required to lift the piston wholly out of the cylinder; and thus afford a free escape. In Fig. 1 the piston is shown as provided with openings  $a$  in its rim and  $b$  in its disk. It will be seen that this device will afford a graduated escape as the piston is lifted, for as the holes  $a$  pass above the upper edge of the cylinder the escape is increased, and when the piston is forced above the cylinder the escape is free, as in the construction shown in Fig. 3.

In Fig. 2 the piston is shown as having its rim serrated, thus affording flaring openings  $d$ . This is perhaps the most preferable construction, as it gives a still more graduated escape as the piston is lifted, for as the piston rises above the edge of the cylinder the holes  $d$  grow wider as well as longer.

I am aware that two perforated cylinders—one within the other—have been combined to operate in a safety-valve for a dissimilar purpose, (see Patent No. 215,242, May 13, 1879,) and I do not, therefore, claim as my invention that which would include such a construction.

A second feature of my invention consists in providing an improved lever for lifting the valve manually. This consists of the compound lever  $E E'$ . The lever  $E'$  is pivoted to the case B at  $e'$ , and extends into the case and under the valve-stem spring-ledge. On the top of this lever is pivoted the second lever,  $E$ , at  $e$ . This lever has a foot which bears upon a lug,  $b'$ , on the side of the shell or case B. The engineer's connecting-cord connects with the lever  $E$ . It will be evident to any one that much less exertion will be required to raise the valve with this leverage than by a single lever, as is now commonly used.

What I claim as new is—

1. In a safety-valve, substantially as described, the combination of a cylinder and a differential valve, the upper part of which is a narrow flanged or rimmed piston within the cylinder, from which it can be lifted to allow steam to escape between its flanged rim and the upper edge of the cylinder, for the purpose set forth.

2. In a safety-valve, substantially as described, the combination of a cylinder and a differential valve, the upper part of which is a narrow flanged or rimmed piston provided with passages in its rim, and seated within a cylinder, from which it can be lifted partially or wholly, and when partially lifted will afford a partial escape through said passages, as set forth.
- 10 3. In a safety-valve, the combination, substantially as shown, of a cylinder and a differential valve, the upper part of which is a piston having a narrow serrated rim or flange affording flaring openings *d*, and seated with-
- 15 in said cylinder, from which it can be lifted

partially or wholly, and when partially lifted will afford a graduated partial escape through said openings, as set forth.

4. In a safety-valve, the combination, with the valve, valve-stem, and weighting-spring, of a compound lever, E E', arranged to operate substantially as and for the purposes mentioned.

In testimony whereof I affix my signature in presence of two witnesses.

ALBERT H. JARECKI.

Witnesses:

JNO. K. HALLOCK,  
ROBT. H. PORTER.