

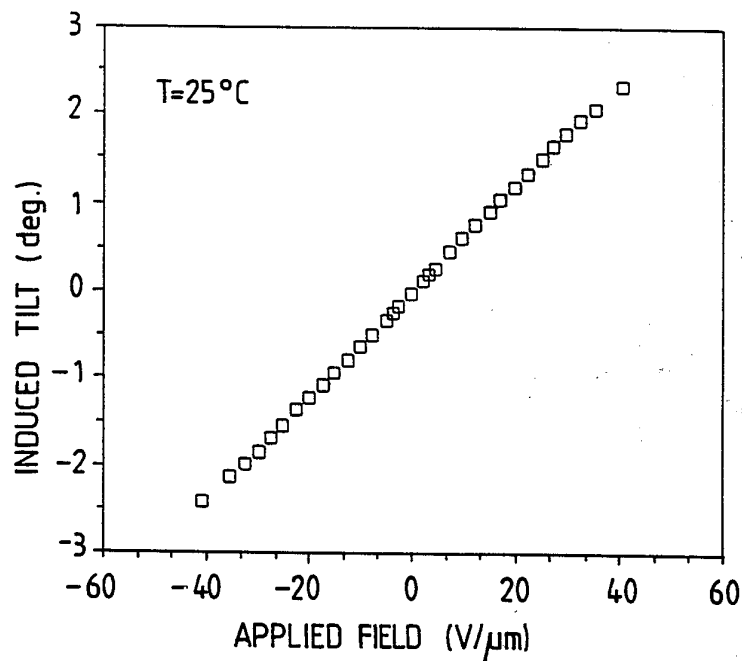

INTERNATIONAL APPLICATION PUBLISHED UNDER THE PATENT COOPERATION TREATY (PCT)

| | | |
|------------------------------------------------------------------------------------------------------------------------------------------------------------------------------------------------------------------------------------------------------------------------------------------------------------------------------------------------------------------------------------------------------------------------------------------------------------------------------------------------------------------------------------------------------------------------------------------------------------------------------------------------------------------------------------------------------------------------------------------------------------------------------------------------------------------------------------------------------------------------------------------------------|-----------|----------------------------------------------------------------------------------------------------------------------------------------------------------------------------------------------------------------------------------------------------------------------------------------------------------------------------------------------------------------------------------------------------------------------------------------------------------------------------------------------------------|
| (51) International Patent Classification ⁵ : G02F 1/133 | A1 | (11) International Publication Number: WO 90/09614 (43) International Publication Date: 23 August 1990 (23.08.90) |
| (21) International Application Number: PCT/SE90/00109 (22) International Filing Date: 16 February 1990 (16.02.90) (30) Priority data: 8900563-1 16 February 1989 (16.02.89) SE (71) Applicant (for all designated States except US): S.T. LAGERWALL S.A.R.L. [FR/FR]; 8, corniche Bonaparte, F-83150 Bandol (FR). (72) Inventors; and (75) Inventors/Applicants (for US only) : DAHL, Ingolf [SE/SE]; Rundbergsgatan 11, S-431 61 Mölndal (SE). ANDERSSON, Gunnar [SE/SE]; Holtermansgatan 5, S-411 29 Göteborg (SE). STEBLER, Bengt [SE/SE]; Carlbergsgatan 19, S-412 66 Göteborg (SE). KOMITOV, Lachezar [BG/SE]; Landalabergen 14, S-411 29 Göteborg (SE). SKARP, Kent [SE/SE]; Bräckavägen 45, S-427 00 Lindome (SE). LAGERWALL, Sven, Torbjörn [SE/SE]; Snäckvägen 30B, S-414 75 Göteborg (SE). | | (74) Agents: HJÄRNE, Per-Urban et al.; H. Albihns Patentbyrå AB, Box 3137, S-103 62 Stockholm (SE). (81) Designated States: AT (European patent), BE (European patent), CH (European patent), DE (European patent), DK (European patent), ES (European patent), FR (European patent), GB (European patent), IT (European patent), JP, KR, LU (European patent), NL (European patent), SE (European patent), US. Published <i>With international search report.</i> |

(54) Title: LIQUID CRYSTAL DEVICES USING A LINEAR ELECTRO-OPTIC EFFECT



(57) Abstract

Compound liquid crystal devices are disclosed which amplify the often small or relatively small values of achievable directional shift in the effective optic axis given by the electroclinic or ferroelectric response. By carefully choosing the relative directions of the optic axes in the elements, the undesired chromatic properties can be made to partially cancel, giving the combination a much smaller chromaticity than the single cells. Examples of device implementations are bright reflective displays, modulators, spatial light modulators, beam switches and deflectors, and polarization or phaseshifting switches capable of switching between binary or triple states. Multiple element compounds can instead enhance the chromatic dependence, giving electrically timable colour filters, e.g. such that can be rapidly scanned between three positions in the CIE colour diagram.

FOR THE PURPOSES OF INFORMATION ONLY

Codes used to identify States party to the PCT on the front pages of pamphlets publishing international applications under the PCT.

| | | | | | |
|----|------------------------------|----|------------------------------------------|----|--------------------------|
| AT | Austria | ES | Spain | MG | Madagascar |
| AU | Australia | FI | Finland | ML | Mali |
| BB | Barbados | FR | France | MR | Mauritania |
| BE | Belgium | GA | Gabon | MW | Malawi |
| BF | Burkina Fasso | GB | United Kingdom | NL | Netherlands |
| BG | Bulgaria | HU | Hungary | NO | Norway |
| BJ | Benin | IT | Italy | RO | Romania |
| BR | Brazil | JP | Japan | SD | Sudan |
| CA | Canada | KP | Democratic People's Republic of Korea | SE | Sweden |
| CF | Central African Republic | KR | Republic of Korea | SN | Senegal |
| CG | Congo | LI | Liechtenstein | SU | Soviet Union |
| CH | Switzerland | LK | Sri Lanka | TD | Chad |
| CM | Cameroon | LJ | Luxembourg | TG | Togo |
| DE | Germany, Federal Republic of | MC | Monaco | US | United States of America |
| DK | Denmark | | | | |

LIQUID CRYSTAL DEVICES USING A LINEAR ELECTRO-OPTIC EFFECTDescription of Device Principle and Embodiments

If the rotation of the polarization plane is insufficient to produce a high contrast-high brightness effect, this
5 may be remedied by letting the light pass the cell twice, using a reflector. In this case the optimum condition is recovered when a quarterplate retarder is inserted between the reflector and the liquid crystal which has to be a
10 halfwave plate of a material with a tilt θ of 11.25 degrees. Such a value of the tilt, or apparent tilt, is indeed common in many SSFLC cells. A difficulty with this design is that the property of being a halfwave of a quarterwave plate can be fulfilled only for a certain
15 wavelength λ . If not properly made, the design of the compound cell will add the chromaticity of the parts so that the cell is more chromatic than either component. On the contrary, with axis directions carefully chosen, a compensation of the wavelength dependence can be achieved so that the combination is nearly achromatic, i.e. with a
20 flat wavelength transmission characteristics, thus well adapted to process even white light.

A second method to increase an insufficient rotation of the polarization plane is to use several liquid crystal
25 cells, in series eventually glued into one unit. Again, if this is just made in a repetitive way, the wavelength dependence of the elements will add to an undesired chromaticity, whereas the combination can be made essentially achromatic already in a double cell, by choosing the optic
30 axes orthogonal instead of parallel.

If ferroelectric or electroclinic materials are used for the implementation of (reflective, double or multiple cell) devices described below does not, generally speak-

ing, alter the optical design of these devices. Their use and performance will be different according to the utilized materials. Both give very rapid (submicrosecond) electrooptic response.

5

Whereas the SSFLC cells are characterized by a pronounced threshold, and may switch between two bistable states, the SMFLC cells have no threshold, an induced tilt angle increasing linearly with the applied field E (cf. Figure 2) and therefore an electrically controlled, continuous grey-scale. It is of course also possible to add or mix these properties in a device, filling the different component cells with different materials, ferroelectric and electroclinic, respectively.

10

15

One of the most attractive devices for real-time optical processing, incoherent-coherent, and thus also Fourier transformation of images is a spatial light modulator, with an optically addressed photoconductor layer or pixel pattern, acting on liquid crystal. Such a device should operate at high speed and low power, would not require memory, but would greatly benefit from a continuous grey scale. Furthermore, the liquid crystal in this application should preferably work in reflective mode. Thus a single-cell reflective soft-mode device would seem ideal. A surface-stabilized device using a tilted smectic would operate in the same way, but with the maximum contrast, without grey scale.

20

25

30

One possibility to arrange a reflective device is to take a transmissive device, consisting of one $\lambda/2$ cell between two crossed polarizers, and place the whole arrangement in front of a mirror. Then, we will gain in contrast compared to a single passage of light through the cell, but at the same time we lose in intensity. The optimum zero-field preset angle Ψ_0 for maximum light intensity modulation becomes 30° , compared to 22.5° for the simple

35

transmissive device. For a tilt angle swing of $\pm 10^\circ$, we could then switch between 17% reflection and 94% reflection, measured relative to the intensity of the incoming linearly polarized light at the optimum wavelength.

A better arrangement is to replace the polarizer next to the mirror by a $\lambda/4$ retarder plate, giving the arrangement in Figure 3(b). In this device, we use the ability of the mirror to change the state of polarization of light. Linearly polarized light, reflected by a mirror at normal incidence, will still be linearly polarized in the same plane, but circularly polarized light will change its handedness. It is thus possible to see the mirror image if a linear polarizer is placed in front of a mirror. If instead a circular polarizer is placed in front of the mirror, the mirror will appear black. To get full modulation of a ferroelectric liquid-crystal device, it should thus be able to switch the light falling on the mirror, from being linearly polarized to become circularly polarized. This could be accomplished by the $\lambda/4$ cell shown in Figure 3(a), but would require a 45 degree swing of the optic axis to get full modulation. This means it would require a 22.5 degree material, so far only available as SSFLC, not yet approached by SMFLC. Using a $\lambda/2$ cell together with a fixed $\lambda/4$ retarder, however, as in the setup of Figure 3(b), the device can be realized with either C* or A* material, for instance, where the tilt (C*) or the maximum induced tilt (A*) is 11.25 degrees. We can arrange the orientation of the polarizer, the SMFLC cell, and the retarder plate in various ways, but a comparison indicates that the arrangement shown in Figure 3(b) gives optimum wavelength characteristics: If the slow axis in the case of a soft-mode cell is made to turn between 0° and 22.5° relative to the transmission direction of the polarizer, the slow axis of the $\lambda/4$ plate should be at the angle 45° relative to the polar-

SUBSTITUTE SHEET

izer. Thus the retarding effects of the active cell and of the fixed retarder plate should to some degree be counter-acting. The spectral characteristics of such a device are shown in Figure 4. The wavelength behaviour is comparable to that of a double electroclinic cell (see below), with better achromaticity at maximum reflection, but not so good extinction at minimum reflection. This property could be further optimized by tailoring the dispersion of Δn .

10 Even if the tendency today goes towards backlit displays, there will always be a need for screens working mainly in reflection - either because of minimum power requirements or because of powerful ambient illumination. For high resolution or video applications, the multiplexed single-cell C* reflective devices, or single-cell A* reflective devices, combined with thin-film transistors offer the most powerful solutions. It might be pointed out that the described arrangement, extended by a suitable polarizer behind a transflective reflector, works at the same time in transmission. A reasonable and simple choice is to optimize brightness for the reflective mode, which has to be paid by a 50% light loss in transmission mode, which can always be compensated by backlighting power.

25 As we have seen, a single liquid crystal cell is sufficient for adequately amplifying the polarization plane rotation in the reflective mode. In the transmissive mode, a double cell will be necessary. As in the double pass, with two cells in series we can amplify a tilt θ to the value 8θ , when talking of the amount of rotation of polarization. Each cell contributes to a turn of 4θ : an induced tilt angle of 10° could thus by the use of two cells turn the plane of polarization by 80° , and as before, 11.25° of induced tilt is needed if we want to achieve the ideal value of 90° .

Since the possible change in tilt angle is twice the

maximum tilt angle, we see that the maximum tilt angle should be multiplied by 8 to give maximum rotation of the plane of polarization. Moreover, such pairs can be piled to further enhance the effect: The optical rotation grows linearly with the number of devices.

To obtain the light valve device in practice, we assume that two SMFLC cells are placed between two crossed polarizers, and we want zero transmission at one limiting value of the control voltage and maximum transmission at the other one. The preferred choice is then to place two identical $\lambda/2$ cells on top of each other, in such a way that the zero transmission state is obtained when the slow optic axes of the two cells are perpendicular to each other, coinciding with the polarizer and analyzer directions, respectively, as shown in Figures 5 and 6(a). When changing the applied voltage, the optic axis of the first cell should swing out counterclockwise to the angle Ψ , and the optic axis of the second cell should turn clockwise, to the angle $90^\circ - \Psi$, measured relative to the polarizer transmission direction. The angle between the optic axes then becomes $90^\circ - 2\Psi$, and the plane of polarization is thus turned the angle $180^\circ - 4\Psi$, which gives a four times magnification, the tilt angle swing needs to be $+11.25^\circ$ and the zero field azimuth angle Ψ_0 of the two cells should thus be chosen as 11.25° and 78.75° , respectively. This tilt angle swing is in the range of what is achievable with present materials. In principle, the same operation would be possible if the slow optic axes of the two cells had been parallel in the initial state [cf. Figure 5(b)]. The reason why we choose them perpendicular is that the $\lambda/2$ condition is only fulfilled for one specific wavelength λ , whereas it is clearly desirable to have the device working in the prescribed mode over as large a wavelength region as possible. By interchanging the fast and slow directions of one of the cells, the chromaticity partly compensates instead of add, so that

SUBSTITUTE SHEET

the combination will show fairly flat wavelength characteristics, especially towards the red-infrared part of the spectrum. The calculated transmission spectra are shown in Figure 6, where a comparison is made between the two cases. If we pile two such pairs on top of each other (this combination requiring then only half of 11.25° tilt in each single cell for full modulation depth), the wavelength characteristics will become even slightly more flat. As we will see below, this combination of two soft mode cells is also suitable to be included in colour switching devices.

With a continuous varying control voltage, an excellent grey-scale device is achieved, with a contrast high enough (set by the polarizers and the cell quality) to fully utilize the grey-scale dynamics. The price we have to pay is the complexity of two cells and four electrodes. In principle, by filling one cell with one smectic-A mixture and the other with its optical antipode, the same sign of voltage could be used over the two cells, and then in principle a construction with only two electrodes is possible. To make practical devices out of this idea, sheets of smectic-A* or -C* polymer could be laminated in a plywoodlike structure. This would enable close packing without mixing of the optical antipodes. In this context, one might contemplate the basic question about the fundamental prerequisites for the electroclinic effect. Maybe we could expect an electroclinic effect in some polymers, made out of chiral monomers, even without the smectic layer structure. Maybe even the presence of a polymeric backbone could replace the smectic layer structure as symmetry breaking element.

We could thus obtain an optical component that is as fast as a single electroclinic cell, but with possibilities to give full modulation of light or, alternatively, to rotate the polarization plane by 90° . Since we could make use of

small tilt angles, we could choose the temperature of the cells a bit further inside the smectic-A phase, away from the phase transition to smectic-C, and make use of the smaller, but faster, and less temperature-dependent electroclinic effect there. The additive properties of multiple electroclinic cells could also be used to make analog or logical addition. There are also numerous applications, where the cells could be combined with polarization-sensitive deflective optical components, to control the light path through an optic system. There are several different polarization-sensitive deflective optical devices available. Such components could use birefringent plates with suitably arranged optic axes, gratings, especially those made of birefringent material, Brewster windows, total internal reflection in birefringent materials, the reflective properties of one-dimensional conductors, etc. By placing electroclinic cell combinations and this other component in alternating order in a row, we could control where the deflection should occur. In this way we could control and scan the lateral position of a light beam, which otherwise is a difficult problem. We could also construct optical switchboards of high speed and with relatively low light losses. These switchboards could be constructed by stacking electroclinic cell pairs together with birefringent plates of different thicknesses and with oblique optic axes as in Figure 7. Such a device could direct a light beam to any out of a big number of exit lines, or vice versa. If the liquid crystal cell pairs are arranged as linear arrays, a big number of entrance lines, by a quite simple, compact, and fast construction. The light absorption in this type of switchboard will only be caused by material imperfections and not by the working principles as such, and thus the light losses could be kept quite small.

A great number of deviators, beam splitters, beam switch-

SUBSTITUTE SHEET

ers, phase shifters and polarization switches could be designed either using SSFLC or SMFLC double cells in combination with prisms and retarders. We show some examples of beam splitters in Figure 6. In Figure 9 are shown simple examples of optical switchboards with a double cell in front and a deviator or communications switch with a single cell actively controlling the change in birefringence and thereby the refraction and total reflection.

10

Some examples of polarization switches using double-cells are shown in Figure 10. The zero-field state is illustrated at the top. One sign of the now turns Ψ to zero making the incoming vertical polarization staying vertical, whereas the other sign turns the polarization by 90 degrees. The zero field state gives circularly polarized light. By turning the back retarder 45 degrees linear polarization goes to circular and vice versa.

15

20

An optical computing element can be obtained in a variety of LC technologies, illustrated in a general way by Figure 11. Different threshold properties can be chosen not only by way of the liquid crystal but its combination with non linear-elements. Different logic can be chosen, like amplitude or polarization logic, the latter using binary or ternary states as just described.

25

30

In addition to the already mentioned applications, the SMFLC effect can be explored for high-speed colour switches. The cell behaves like a birefringent plate, with an almost constant phase difference δ and a field-sensitive direction of the optic axis. We can combine it with additional birefringent plates, to obtain switching between colours instead of switching between black and white. The possible change in position of the optic axis for the single cell is presently of the order $\pm 10^\circ$, and we want here to discuss the possibilities to get significant

35

SUBSTITUTE SHEET

colour changes in spite of the somewhat limited angular range of the electroclinic effect. For future materials with higher values of the induced tilt, the colour scan domain will increase accordingly. But already with available materials, there are highly interesting possibilities for colour generation, with switching between two or three significantly different colours for one electroclinic cell. With two filter combinations in series we could get switching between a great number of different colours, covering a large part of the physiological colour spectrum.

We give two examples of soft-mode cell combinations, containing fixed birefringence plates and working in transmission. The colour coordinates are calculated from the transmission spectra. The thickness of the cells has been chosen to give a phase retardation of $\lambda/2$ at some wavelength, since approximately this thickness should give maximum optical response and speed for minimum applied voltage.

The first combination may be denoted a sliding-minimum filter (see Figure 12). We build up this combination by starting with a polarizer and a fixed birefringence plate of optical path difference of 5460\AA , that is a normal λ plate, turned 45° . (All angles are measured relative to the transmission direction of the polarizer). Then, we take a $\lambda/4$ plate, with path difference 1365\AA , parallel to the polarizer, followed by an SMFLC cell and an analyzer at 90° . The thickness of the soft-mode cell is $2.02\ \mu\text{m}$, which gives $\lambda/2$ plate at 5460\AA . If the optic axis of this cell can be driven from -10° to $+10^\circ$ by an electric field, we will get the transmission curves displayed in Figure 12(b), where we can see how the position of the transmission minimum is displaced by the field. If light at wavelengths far from the minima are blocked by filters as indicated in Figure 12(b), we can generate colours along the trace shown in the CIE diagram shown in

SUBSTITUTE SHEET

Figure 12(c): On the way from greenish blue to orange we will pass purple and red. The parameters are not fully optimized, but are chosen to give an illustration of what can be achieved. The transmission of polarized light through the cell (weighed by the eye sensitivity) varies between 5% and 17%.

As a second example we choose a combination containing two pairs of electroclinic cells in series, with a polarizer also between the cells. The idea is that one of the cells should control the blue-yellow contrast, the other the green-red contrast. By placing two colour switches in series, one switching continuously between blue and yellow with neutral transmission in red and green, and another switching continuously between green and red, with neutral transmission for blue and yellow, all colour hues should be obtainable. Then we want each cell to generate approximately straight lines in the CIE diagram, and thus the sliding-minimum combination is unsuitable. Instead, we can work with what we denote "pivot filters". If we want a shift between low-blue, high-yellow and high-blue, low-yellow transmission, it is reasonable to look for transmission curves that have a pivot point, that is, a point where the transmission is independent of the position of the optic axis of the electroclinic cell, at some wavelength in green. If we then maximize the change of the derivative at this fixed point, we are likely to achieve quite good sensitivity. We will also place a fixed point in the red part of the spectrum to give the blue-yellow filter neutral green-red properties. To realize this, we put in series a polarizer, a birefringence plate of optical path difference 2.25λ , where $\lambda = 5300\text{\AA}$ (green) with the axis at 45° to the polarizer, then a soft-mode cell pair, and finally an analyzer (see Figure 13(a)). Each electroclinic cell should have the thickness $1.93 \mu\text{m}$, and the pair should be geometrically arranged and controlled in the same way as previously described for

SUBSTITUTE SHEET

the cell pair in Figure 5. This combination is now going to act as the blue-yellow filter. The green-red filter is the same combination, but with $\lambda = 5750\text{\AA}$ (yellow), and with each electroclinic cell of thickness $2.17\ \mu\text{m}$. The pivot filters could of course have one analyzer/polarizer in common. The optic axes of both electroclinic cell pairs are assumed to be controlled independently, with a swing of 22.5° for each cell. The transmission spectra are shown in Figure 13 (b, c and d). Figure 13(d) displays the area covered in the CIE diagram: It is comparable to that of colour cathode ray tubes, and all different hues can be reached, although the colours, as in the CRT case, are not fully saturated. The transmission of the whole combination varies between 6% and 37%. The filter combinations could be optimized further to give even better characteristics, according to the demands of the possible applications. Especially, the dispersion of the fixed birefringent plates could be tailored to extend the usable wavelength range. Also the sliding-minimum filter becomes much better, but at the same time more complicated if we use a thicker retarder plate together with double electroclinic cells. We then get a "sliding-maximum" filter, with transmission maxima and minima, that could be moved along the wavelength axis by the applied field. Again, these general ideas of colour formation could, of course, also be used in devices containing ferroelectric liquid crystals in the chiral smectic-C phase, where also bigger tilt angles are available. We can also note that it is possible to incorporate multiple cells in the design of narrow band birefringent colour filters, and in this way get tunable Lyot-Öhman filters or tunable Solc-filters. These could be used in various scientific instruments, where speed together with simple, compact, and robust design is attractive.

35

Also in the case of colour generation, reflective devices are of great interest, because of the possibility to

reduce the number of active cell components in the reflective mode. In principle, the analog of the pivot filter combination of Figure 17 could be made with only two electroclinic cells. We will lose in colour saturation compared to the pivot filter combination with four electroclinic cells, but if the filters are combined with a mirror to a thin package, the two passages of light will partly compensate for the loss in colour saturation. At the same time we will lose in brightness, and that is more critical for a reflective device than for a backlit transmissive. Thus a compromise must be made between contrast and brightness. A construction would benefit if colour selective partial polarizers could be included. Such polarizers should absorb only in yellow and blue, or only in red and green. (Also the transmissive pivot colour filters could benefit from such polarizers.) The angular dependence of the device is more critical for a reflective device than for a transmissive. With this limitation, however, the optical component would act as high speed colour mirror, capable of reflecting different colour components in the incoming light, according to the applied control voltages. In combination with the single two pass cell of Figure 3(b) and TFT addressing, it could be used for high resolution colour video screen, with continuous colours and shades, only working in ambient light. If bistable ferroelectric liquid crystals are used instead, corresponding computer displays with a fixed number of colours could be constructed.

The orthogonal chiral smectic liquid crystals are a presently unexplored class of electro-optic materials with high-performance potential. They will be an important complement to the tilted chiral smectics, whose properties and uses in physical devices have been the object of intense research and development over the last 5 years.

The study of the physical and electro-optical properties

SUBSTITUTE SHEET

of the smectic-A* phase, being the most important representative, and so far practically also the only available material of the orthogonal smectic class, has revealed that its applications will lie in slightly
5 different areas than the applications of the smectic-C* phase, with a certain area of overlap. The existence of a bistable electro-optic effect in the C* phase makes this class of materials generally more useful. On the other hand, the electro-optic effect in the A* phase is the most
10 rapid of those found in liquid crystals to date. Response times are presently of the order to 500 ns at room temperature, should become much less at elevated temperatures, and even for the future polymer A* materials we may expect values below 100 μ s. Modulation linearity and
15 available continuous gray shade add to the usefulness of the effect, together with the possibility to use it also in the ultraviolet and infrared regions. On the negative side is a limited modulation depth or contrast if high transmission is required. This is due to the limited
20 amplitude in the induced tilt, which is the underlying basic effect (electroclinic effect). The expected forthcoming rapid development in broadband smectic-A* mixtures is likely to change this situation.

25 As single electro-optic components, the performance of the smectic-A* and C* devices have to be compared to those of available materials using electro-optic, magneto-optic, and acousto-optic effects. It is then clear, for instance, that a double A* cell, at least up to about 2MHz, is a
30 much simpler and much more versatile device than a Faraday rotator. Both A* and C* devices would also compare favourably with both Pockels, Kerr, and acoustic-optic modulators. In general terms, the unique feature of liquid crystals is that we may have a birefringence n that is
35 independent of the applied field, which only controls the direction of the optic axis. For the chiral smectic liquid crystals, there are two options: Either we have in the A*

SUBSTITUTE SHEET

phase (or other chiral orthogonal phases) an axis direction that is a linear function of E, whereas the switching speed is independent of E, or we have in the C* phase (or other chiral tilted phases) the opposite case where the
5 much bigger angular deviation is largely independent of E, whereas the switching speed is essentially linear in E. The values of birefringence (0.1-0.3) are giant compared to Δn introduced by Pockels and, especially, Kerr effects. This permits very thin layers to be used and
10 gives the component a very small physical configuration, like a normal polarizer or retarder plate, at the same time as only low voltages (<100 V) are applied. Furthermore, the acceptance angle for the incoming light is much larger than that of a Pockels cell. Together, these properties made FLC (ferroelectric liquid-crystal) devices,
15 especially those using the soft-mode in the A* phase, very attractive for all kinds of cheap and compact shutters and modulators up to about 100 kHz (C*) or about 2 mKz (A*). Compared to the acousto-optic modulators, the FLC devices
20 have the advantage, in spite of their overall compactness, of much higher apertures, especially as beam deflectors or in similar applications. They seem to be suitable for very much the same applications as acousto-optic modulators, e.g. image scanners, printers, and real-time signal-processing devices for correlation, spectral analysis, and
25 more.

The virtually unlimited apertures of liquid crystal devices will also be the basis for SMFLC applications in
30 camera shutters (high-speed photography), permitting not only exposure as time integrals, but control of the aperture function in time (square wave, sawtooth, etc.) and with all parts of the aperture field exposed simultaneously. Applications for stereoscopic displays, for instance using the rapid switching between orthogonal
35 polarization states (cf. Figure 10), and in automatic welding glasses and laser and flash goggles, are similar.

SUBSTITUTE SHEET

The large available active areas also permit simple manufacturing of linear shutter arrays, which probably will replace many optical designs where mechanical devices are used for light deflection, for example, the rotating mirrors in laser printers. The more versatile control possibilities of the linear arrays make new design concepts available. Again, two chiral smectic options are available: Direct drive high-speed A* phase devices with continuous grey scale or multiplexable C* phase devices with no intrinsic grey scale.

Due to the lack of memory in the soft-mode devices, these would have to be active-matrix addressed, electrically or optically, for making two-dimensional discrete arrays. Such arrays, using thin-film transistors and a smectic-A* cell in reflective mode is probably the ultimate in performance for optical computing using liquid crystals, due to the high speed together with the very important depth of continuous grey shades (see Figure 11). The same is true for nondiscrete optical processing devices, like silicon-addressed spatial light modulators.

Several examples of colour generation have already been pointed out above. One application of electroclinic colour switches would be together with black and white cathode ray tubes, where this kind of colour switch could make high resolution more easily obtainable and also allow integration with a polarization modulator for stereoscopic vision. Another example is ferroelectric displays in the "sequential backlighting" approach, where the information is written to the screen one colour at a time, in a rapid time sequence, and the screen is illuminated by a synchronized sequence of coloured flashes. In such a device the inclusion of suitable electroclinic filters means that only one flash lamp is needed, instead of three flash lamps. Finally, we want to stress what we believe is a particularly interesting application of the electroclinic

SUBSTITUTE SHEET

colour filter: Besides colour separation in colour scanners and in general colour sensors, it will, in conjunction with a charge-coupled device (CCD), permit a very simple compact, and cheap colour-TV camera, where the three colours, red, green, and blue, are electrically scanned.

Brief Description of the Drawings

10 In the drawings:

Figure 1 is a schematic view of the liquid crystal between electroded glass plates, showing the projection θ of the induced molecular tilt θ on the glass plates. Also shown are the projection of the molecular orientation (and the optic axis) in the neutral (field $E = 0$) case. In the case drawn the liquid crystal in a tilted bookshelf geometry.

Figure 2 shows the projection of the induced molecular tilt on the glass plates, as a function of applied voltage at 25°C. The liquid crystal mixture used in this example is 88-158 by Merck.

Figure 3 is a reflective single SMFLC cell device, (a) being a simple build-up yet requiring a 45° turn of the optic axis for full modulation, whereas (b), incorporating a birefringent $\lambda/4$ plate, allows full modulation for a zero to 22.5 degree turn of the optic axis.

Figure 4 shows the wavelength dispersion of the transfer properties of the device according to Figure 3(b), in which the $\lambda/2$ condition for the liquid crystal cell and the $\lambda/4$ condition for the retarder plate is fulfilled at wavelength $\lambda = 5460\text{\AA}$.

Figure 5 is a schematic view of an optimized double electroclinic cell between crossed polarizers, in which

SUBSTITUTE SHEET

ψ marks the angle between the optic axis of the first cell and the polarizer, and at the same time $-\psi$ marks the angle between the optic axis of the second cell and the analyzer. ψ varies between 0 degrees, giving extinction, and 22.5 degrees, leading to full transmission.

Figure 6 shows, for an electroclinic cell pair comprising a liquid crystalline substance (ZLI-3774 by Merck in its chiral smectic C* phase) of typical optical character (birefringence and wavelength dependence of the refractive indices), the calculated transmission for two set-ups and as a function of induced electroclinic angle ψ and of wavelength. The set-ups are, in case (a) an arrangement having the optic axes of the two electroclinic cells at right angles to each other at zero electric field, and in case (b) the cells' optic axes are arranged parallel to each other. As is illustrated, the turns of the cells' optic axes are to take place in opposite senses. Over the visible range of light, set-up (a) is seen to result in an almost ideal achromatic behaviour.

Figure 7 shows a schematic view of a light ray multiplexor (a) being built up by one or more doubling units (b), each consisting of an electroclinic cell combination (like that of Figure 5) along with a thick birefringent plate. The relative intensities of the ray components due to splitting in each birefringent plate are determined by the polarization state of incident light controlled by the electroclinic cells.

Figure 8 shows examples of double SMFLC cells glued onto single birefringent prisms, allowing to electrically control the relative intensities of split and deflected light beams.

Figure 9 shows examples of optical switchboards, made up of combined doubled SMFLC cells and double birefringent

SUBSTITUTE SHEET

(9 a, b, c) or ordinary (9 d) prisms, allowing to electrically control the change in birefringence and thereby the two (or four) outgoing components relative intensities (and the conditions of total reflection).

5

Figure 10 shows schematically examples of polarization switches combining retarders with double SMFLC cells; on 10(a), for one particular set-up, the relative orientations of polarizer, retarder and of the zero electric field (dashed lines) or switched (angles $+\psi$ or $-\psi$) optic axes of the SMFLC cells. In 10(b) and (c) are seen arrangements allowing the switching, as illustrated, between orthogonal linearly polarized states via a (zero field) circularly polarized states (in opposite senses) via a (zero field) linearly polarized states.

10
15

Figure 11 is a general outline of an optical computing element, consisting of two partially covered SMFLC reflective devices, each assisted by thin film transistors, and, in between, various conventional optical elements.

20

Figure 12 shows schematically one example of a colour controlling arrangement, here a sliding-minimum-wavelength filter. As seen in (a), a polarizer, a fullwave and a quarter wave plate are followed by a SMFLC cell, an analyzer and finally a passive colour filter, the relative orientations of optical axes marked for each component. The resulting transmission versus wavelength is seen in (b), showing the sliding minimum position depending on the SMFLC optical axis tilt ($\psi=10.5, 0, -5$ or -10 degrees). In (c) the corresponding colour change is seen in a CIE diagram.

25
30

Figure 13 shows a colour switching filter, made up of a combination of two pivot filters (a) that allows a continuous variation of colours. In (b) and (c) are seen the transmission spectra of the two pivot filters, showing

35

SUBSTITUTE SHEET

pivot points at wavelengths 5300Å and 5750Å, respectively. In (d) is shown the "window" in the CIE diagram corresponding to the different hues obtainable if the two pivot filters are varied independently. Stars indicate the blue, green and red phosphors used in cathode ray tubes.

5

SUBSTITUTE SHEET

We claim:

1. A liquid crystal between electroded glass plates, characterized by having two different states of its averaged optic axis projection on the plane of the plates, said states depending on whether the electric field applied between the plates has a positive or negative sign, respectively.
2. A device according to Claim 1, where the liquid crystal is a smectic liquid crystal in a monomeric or polymeric state.
3. A device according to Claim 1, where the liquid crystal is a nematic liquid crystal in a monomeric or polymeric state.
4. A device according to Claims 1, 2, 3, having means of transforming the difference in optic axis direction to a visible effect. Means being polarizers, retarders, reflectors, dyes doped into the liquid crystal or a combination thereof.
5. A device according to Claims 1 to 4, where the optic effect is enhanced by a retarder-reflector combination giving a further rotation of the polarization plane for light traversing the liquid crystal cell in a double pass.
6. A device according to Claims 1 to 5 with liquid crystal cell thickness corresponding to a half-wave plate, where the material gives a difference in said optic axis directions of 22.5 degrees and said retarder is a quarter-wave plate with its slow axis turned 45 degrees relative to the slow axis of the liquid crystal corresponding to one of the field directions.

SUBSTITUTE SHEET

7. A device according to Claims 1 to 5 with liquid crystal cell thickness corresponding to a half-wave plate, where the material gives a difference in said optic axis directions of 22.5 degrees and said retarder is a quarter-wave plate with its slow axis turned 135 degrees relative to the slow axis of the liquid crystal, allowing the device to perform an achromatic operation.
8. A device according to any of the Claims 6 and 7, where the liquid crystal is electrically addressed by an adjacent photoconductor making the reflected light a coherent state information of the light incident on the photoconductor.
9. A device incorporating any combinations of devices according to Claims 1 to 5, in which a second partial reflector is used for selecting, by multiple pass interference, the colour of the light transmitted by the combination, said colour controlled by the electric field.
10. A pair of cells in series, according to any one of Claims 1 to 4, used in transmission, said cells being half-wave plates with their optic axes perpendicular for one field state, and where the material permits a rotation of the optic axis of 22.5 degrees upon reversing the applied field, the polarity of the field applied to the two cells chosen such that on reversing them simultaneously, the angle between said optic axes diminishes from 90 degrees to 45 degrees, said combination turning any incoming polarization parallel to one of the perpendicular axes by the amount of 90 degrees between the two states of opposite voltage, and by the amount of 45 degrees between one active voltage state and zero field state.
11. A multiple n of cell pairs in series as in Claim 10 with a material permitting an optic axis rotation of $22.5/n$ degrees upon reversing the field applied to each cell.

12. A device according to Claim 10 in combination with a quarter-wave plate retarder, said retarder having its optic axis parallel to the direction of polarizer axis and liquid crystal optic axis, said combination giving orthogonal states of linear polarization for the two opposite signs of applied voltage and circularly polarized light for zero voltage.

13. A device according to Claim 10 in combination with a quarter-wave plate retarder, said retarder having its optic axis at 45 degrees to the direction of polarizer axis and liquid crystal optic axes, said combination giving right-handed circularly polarized light for one sign of the control voltage, left-handed for the opposite sign, linearly polarized light for zero applied voltage, and elliptically polarized light of the corresponding handedness for control voltage amplitude giving less than 22.5 degrees axis rotation.

14. A plurality of devices according to Claim 10 or 11, each followed by a birefringent plate for spatially displacing a light beam exiting from each cell pair according to its polarization state.

15. A device according to Claim 10 in combination with a Glan Thomson or equivalent prism, said combination giving a different polarization state and a directional splitting of light corresponding to the sign of the control voltage being applied to the corresponding part of the double cell, said combination making a multichannel electrooptic switch.

16. A simple or double cell device according to Claims 1 to 4 in combination with one or more of birefringent prisms, the combination acting as an electrically controlled beam-splitter.

SUBSTITUTE SHEET

17. A device according to Claims 1 to 4, in which the glass plates are parts in a double prism, said combination acting as a beam splitter or beam switch by controlling the direction of the liquid crystal axis and thereby the reflection of one of the internal glass surfaces.

18. A plurality of single and double cells in combination with polarizers and retarders, where the induced tilt in optic axis of the cells makes the combination an electrically controlled and tunable colour filter.

19. The use of a plurality of single and double cells as of Claim 18 for a scanned colour separation filter in combination with a black and white scanned detector in a TV camera.

SUBSTITUTE SHEET

1 / 12

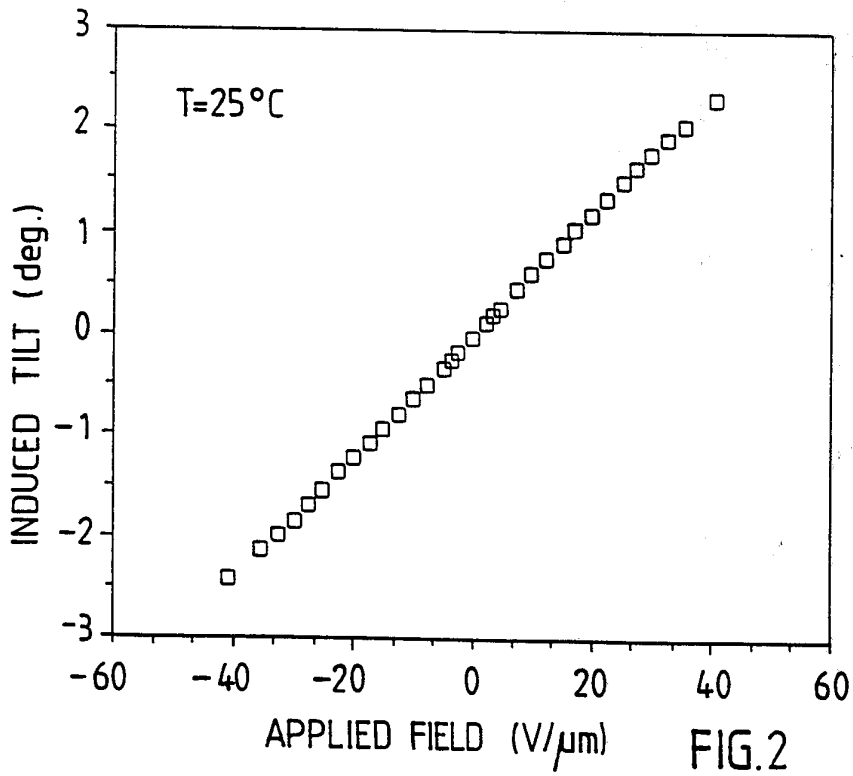
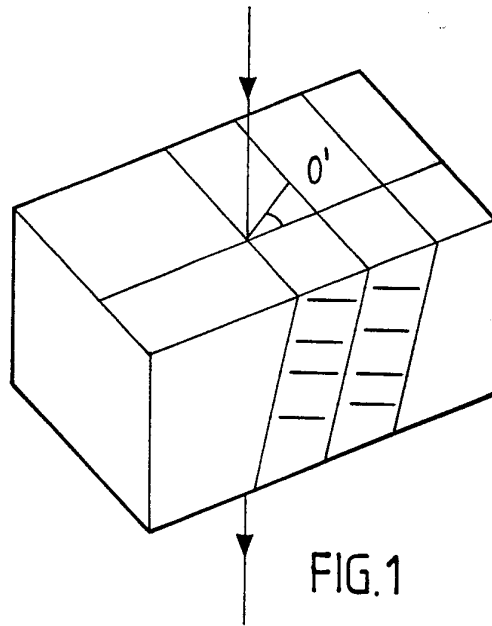

SUBSTITUTE SHEET

ELECTROCLINIC REFLECTIVE DEVICE

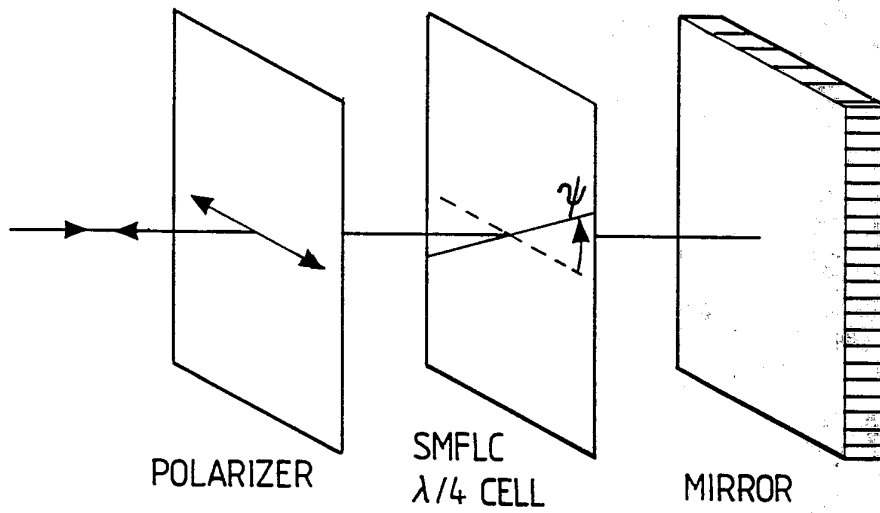

FIG.3A

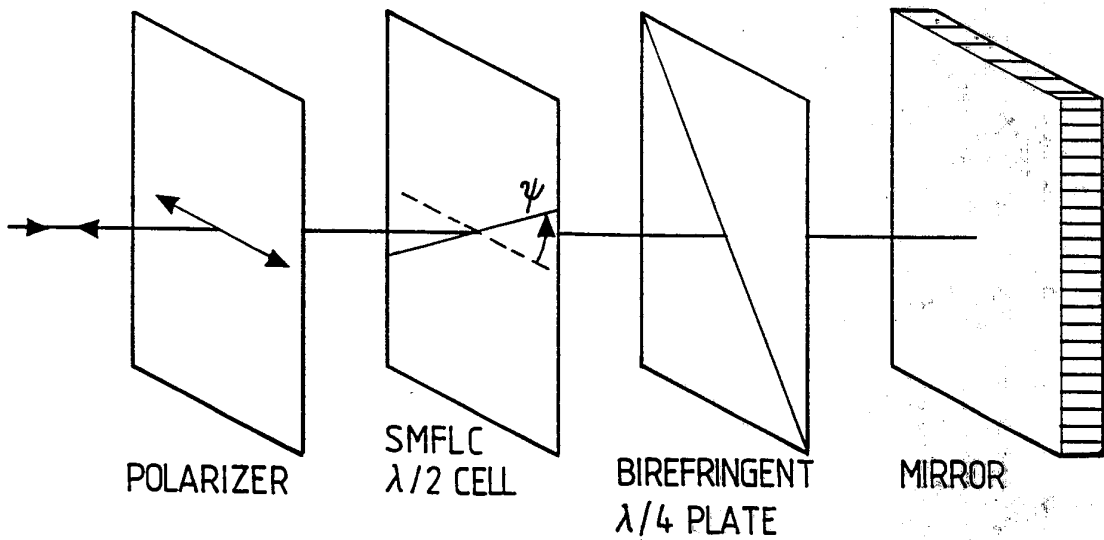

FIG.3B

SUBSTITUTE SHEET

3/12

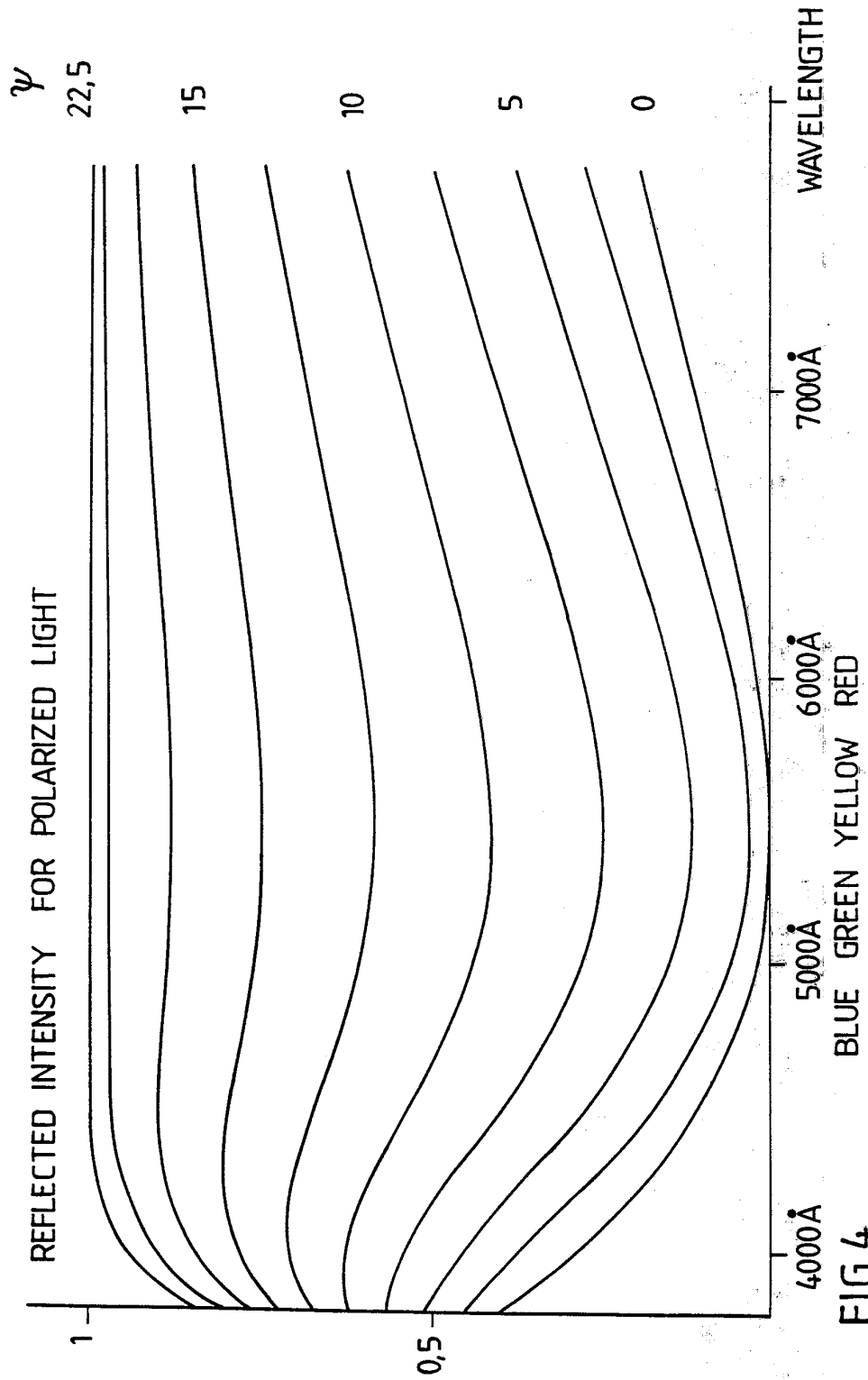

FIG.4

SUBSTITUTE SHEET

4/12

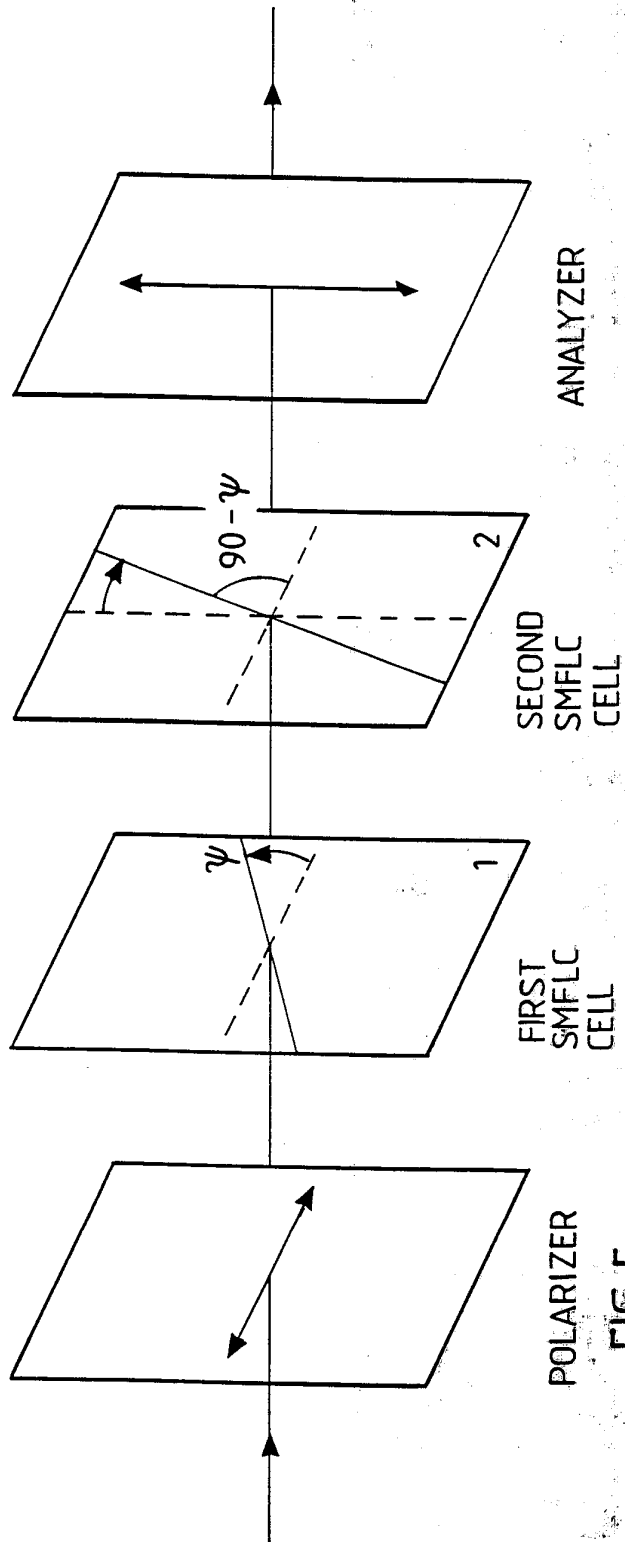

FIG. 5

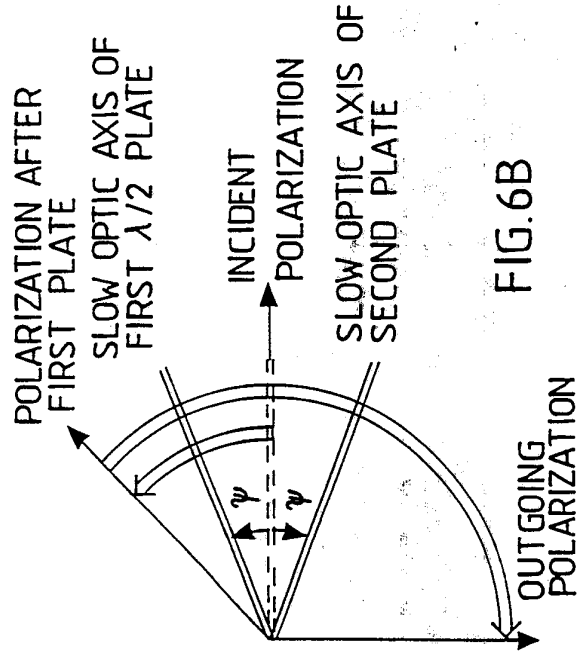
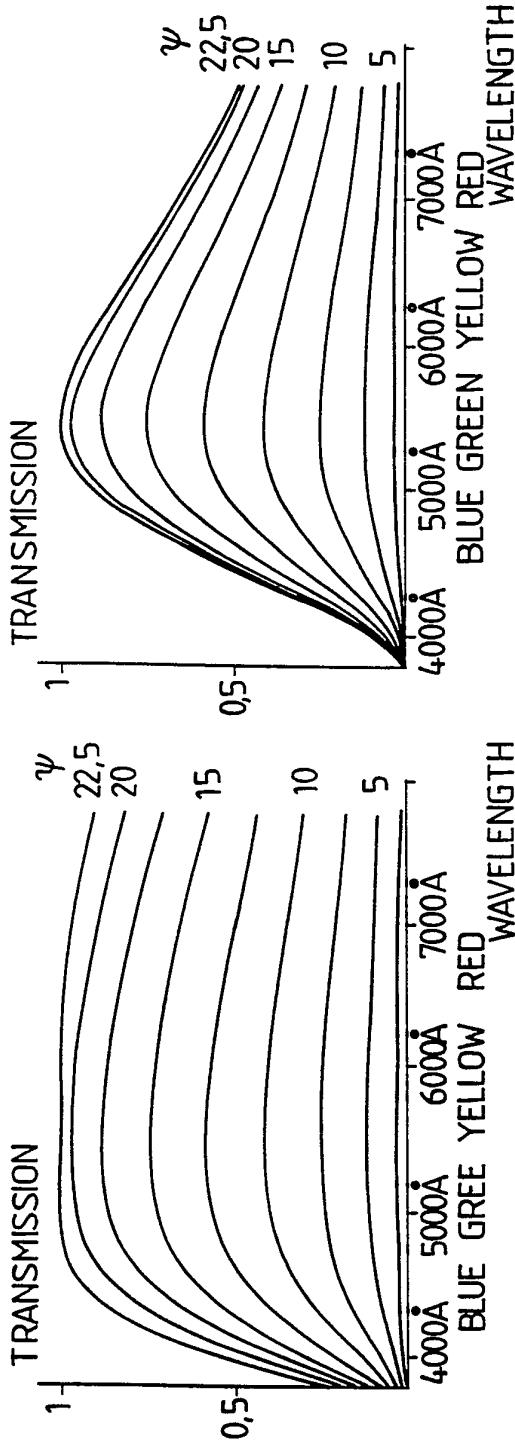

FIG. 6B

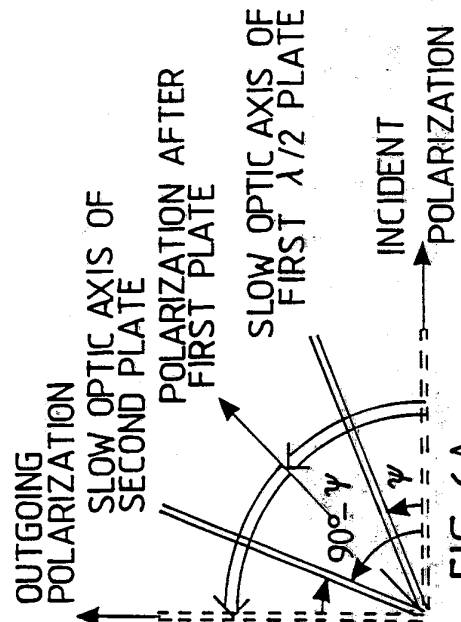

FIG. 6A

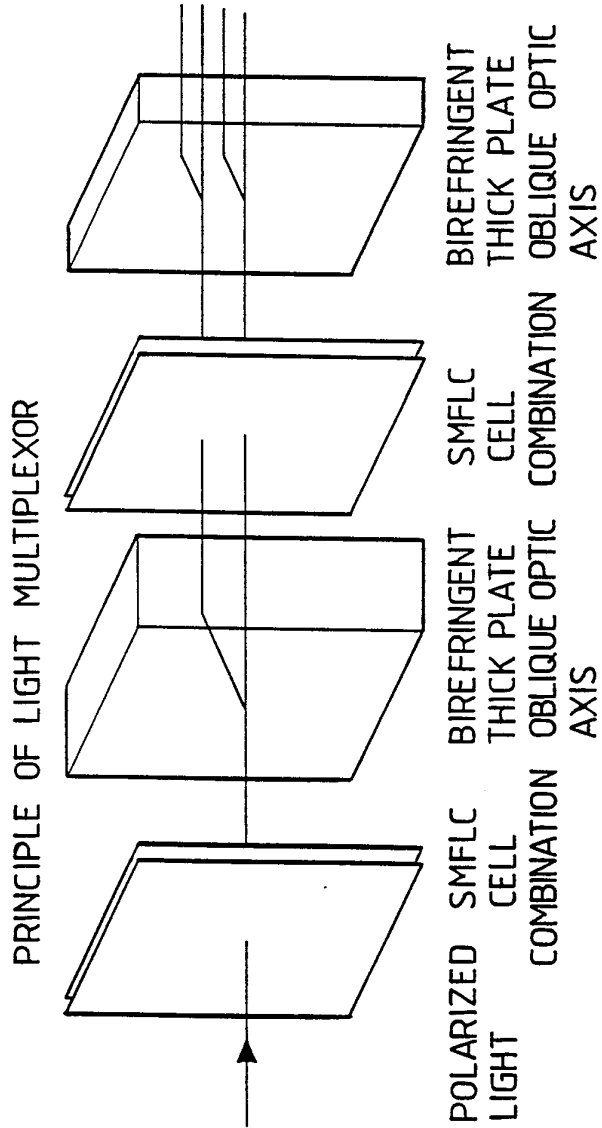
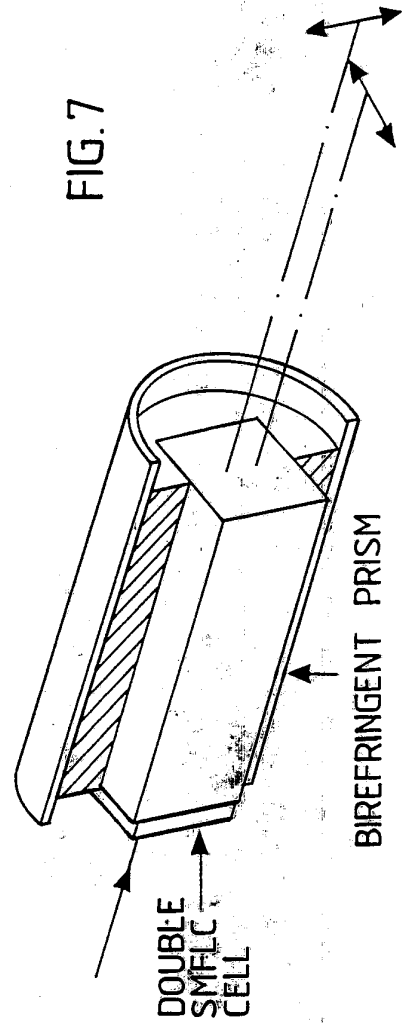

FIG. 7



7/12

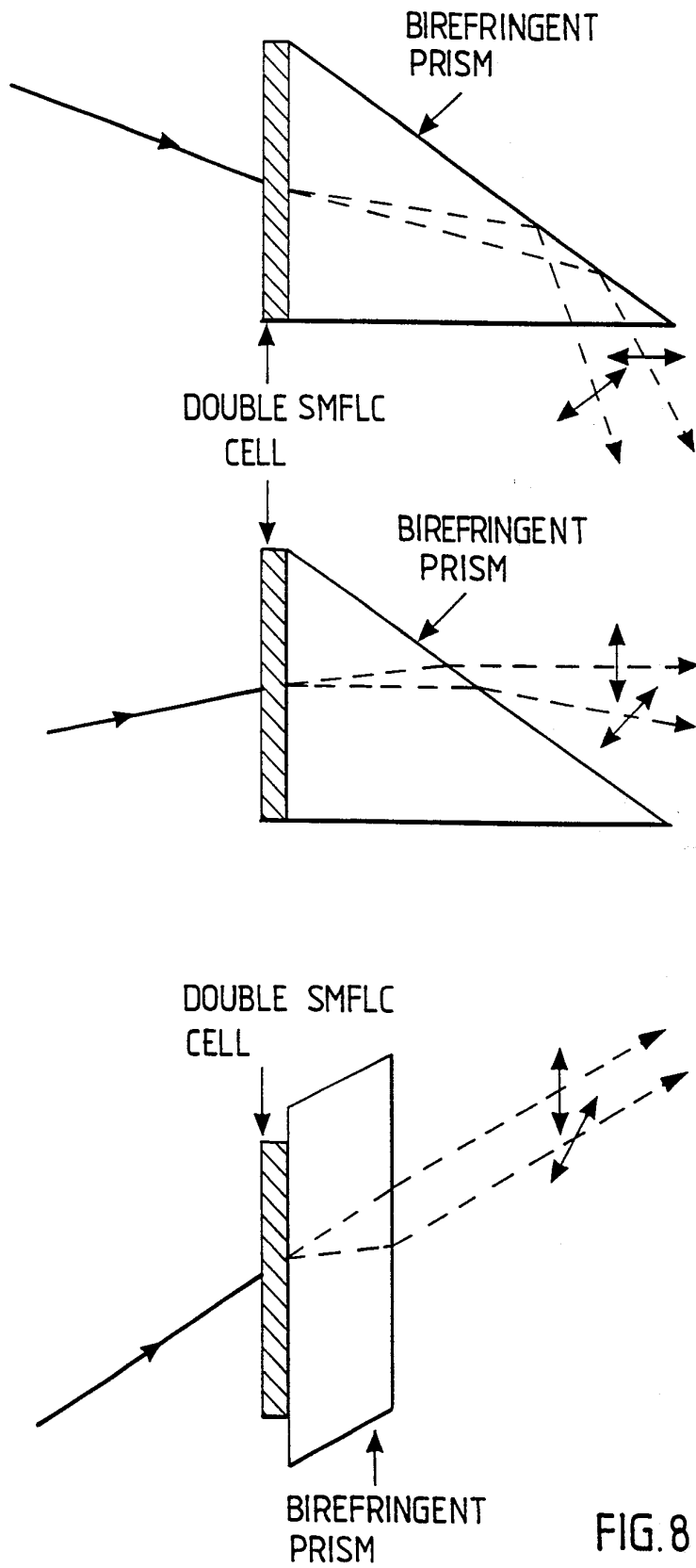
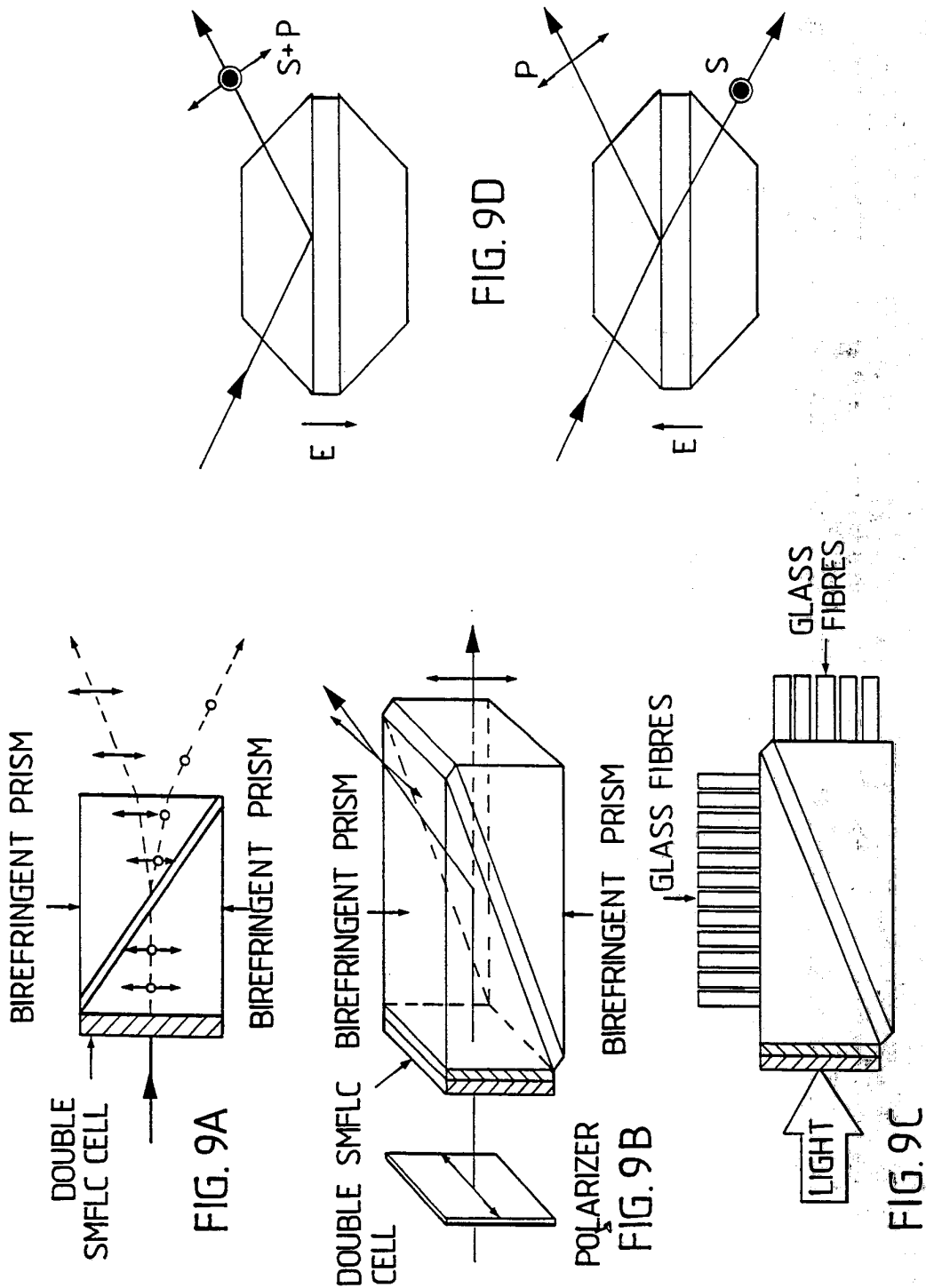
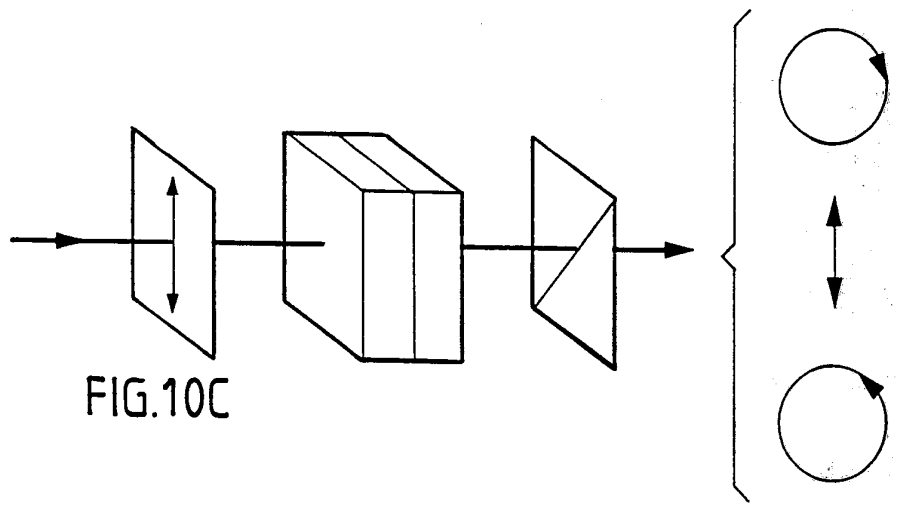
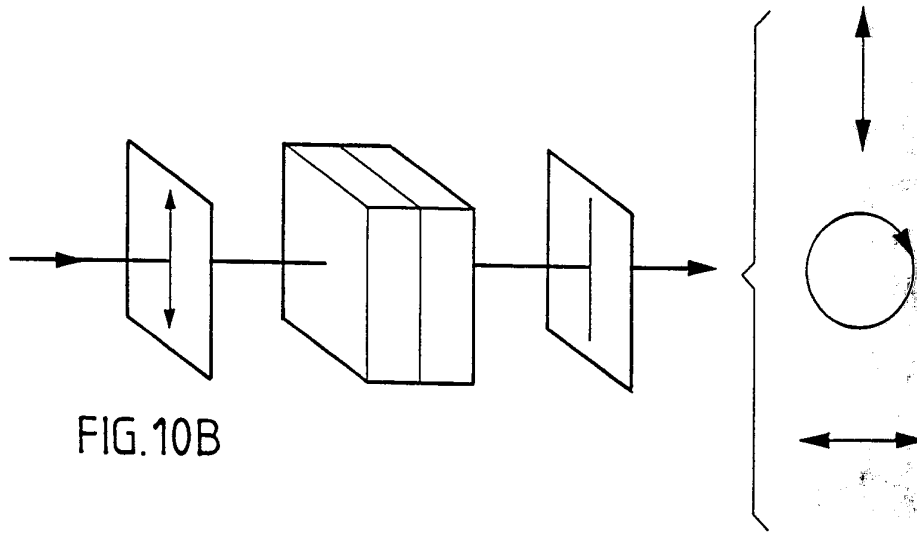
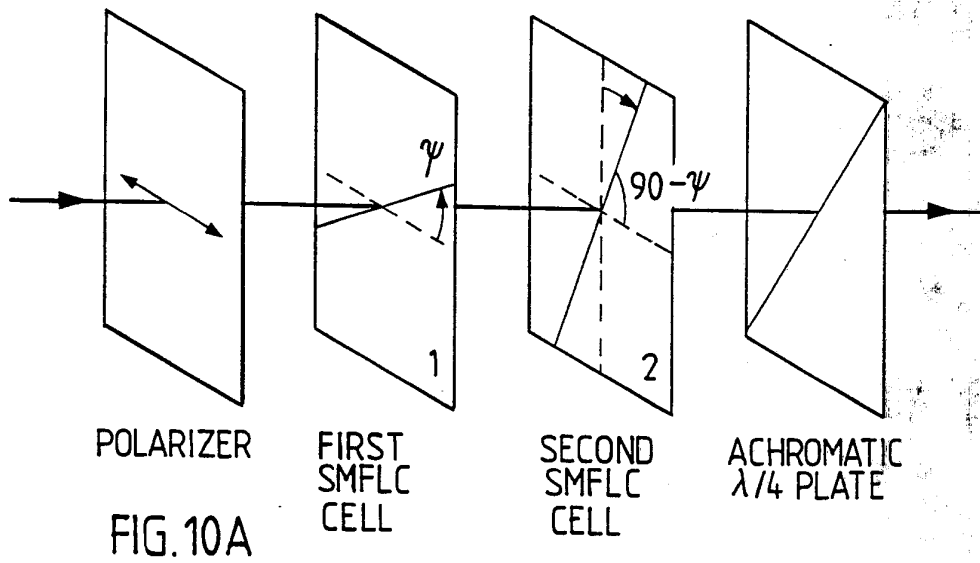

FIG. 8



9/12



SUBSTITUTE SHEET

OPTICAL COMPUTING ELEMENT

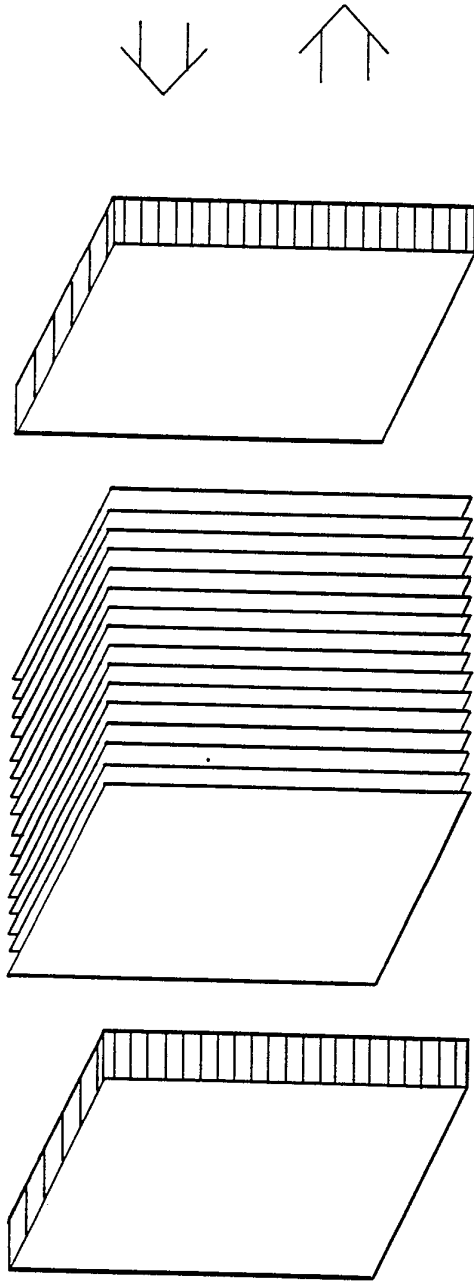

LIGHT SUPPLY

PARTIALLY COVERED SMFLC REFLECTIVE DEVICE ASSISTED BY THIN FILM TRANSISTORS

VARIOUS OPTICAL ELEMENTS AS BEAM APERTURES, FOCUSING ELEMENTS, DEFLECTIVE ELEMENTS, AND OTHER, EITHER AS DISCRETE ELEMENTS OR AS PARTS OF HOLOGRAMS

PARTIALLY COVERED SMFLC REFLECTIVE DEVICE, ASSISTED BY THIN FILM TRANSISTORS

OPTICAL ACCESS



ALSO ELECTRICAL ACCESS TO MODULATORS

FIG. 11

11/12

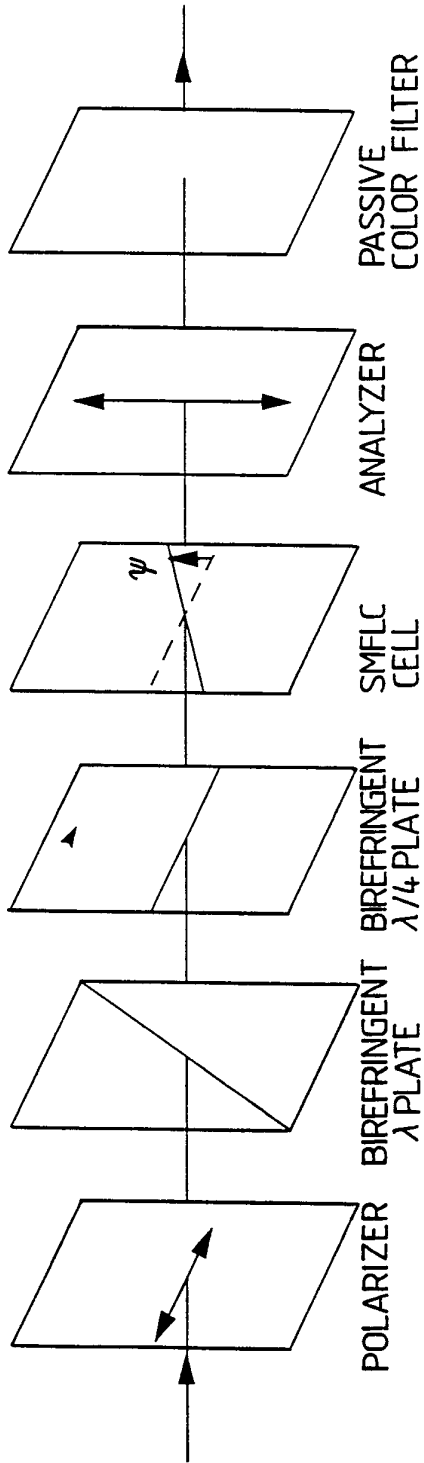

CIE 1931 COLOR DIAGRAM

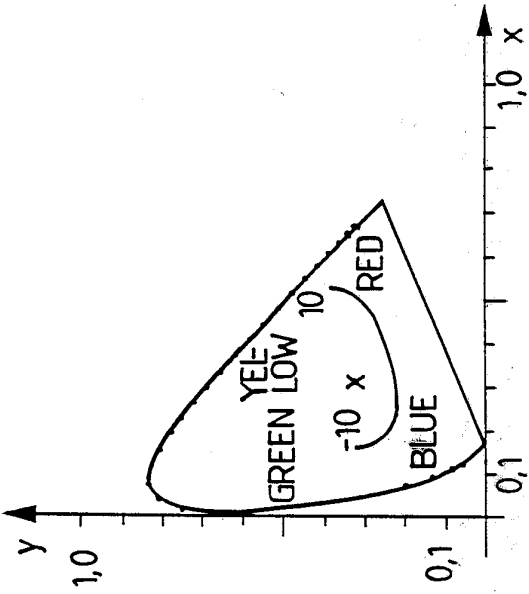

FIG.12B

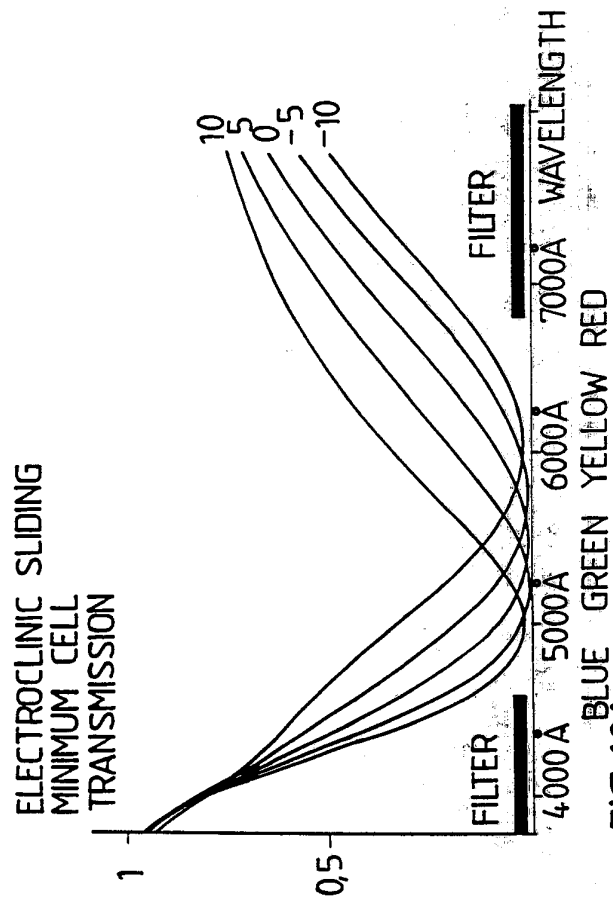

FIG.12A

SUBSTITUTE SHEET

12/12

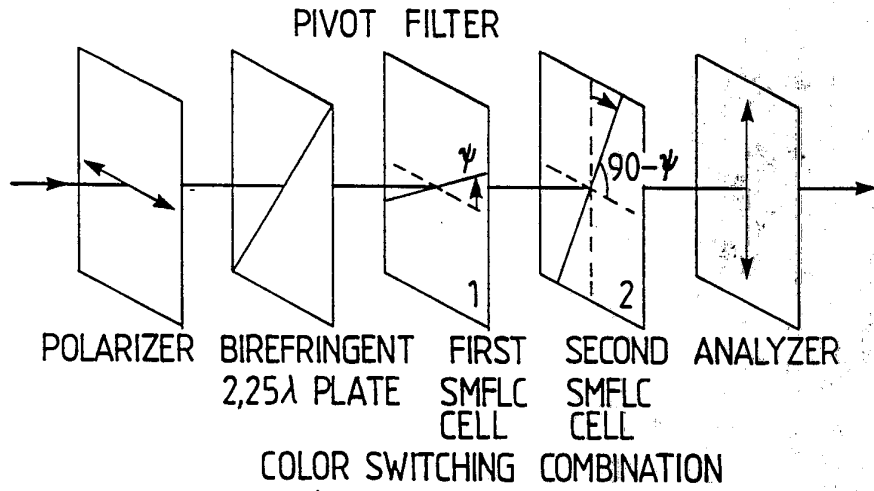
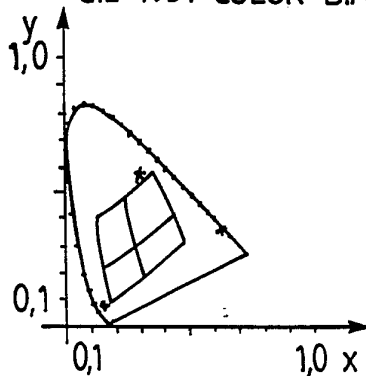
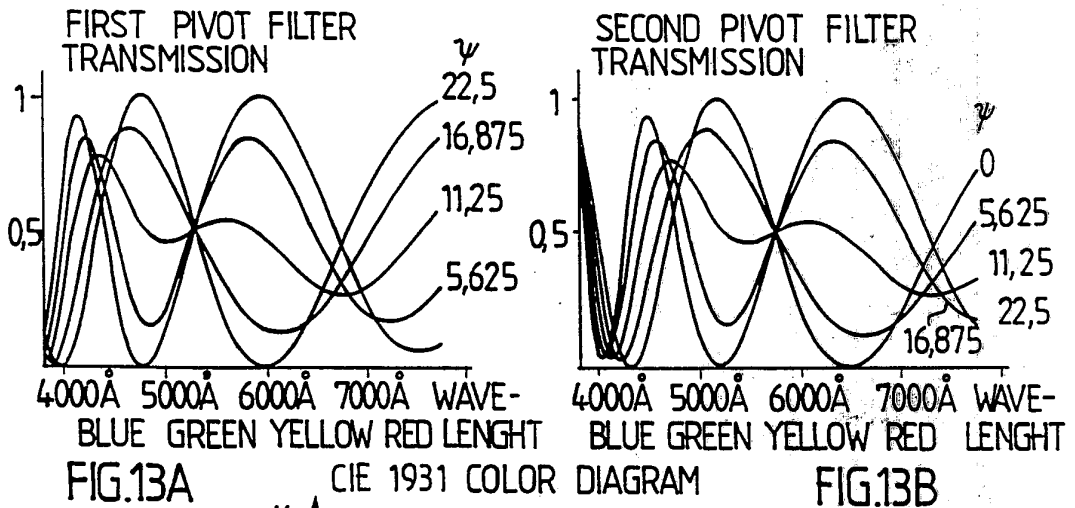



FIG.13



INTERNATIONAL SEARCH REPORT

International Application No PCT/SE 90/00109

| | | | | |
|--------------------------------------------------------------------------------------------------------------------------------------------------------------------------------------------------------------------------------------------------------------------------------------------------------------------------------------------------------------------------------------------------------------------------------------------------------------------------------------------------------------------------------------------------------------------------------------------------------------------------------------------------------------------------------------------------------------------------------------------------------------------------------------------------------------------------------------------------------------------------------------------------------------------------------------------------------------------------------------------------------------------------------------------------------------------------------------------------------------------------------------------------------------------------------------------------------------------------------------------------------------------------------------------------------------------------------------------------------------------------------------------------------------------------------------------------------------------------------------------------------------------------------------|---------------------------------------------------------------------------------------------------------------------------------------------------------------------------------------------------------------------------------------------------------------------------------------------------------------------------------------------------------------------------------------------------------------------------------------------------------------------------------------------------------------------------------------------------------------------------------------------------------------------------------------------------------------------------------|-------------------------------------|---------------------------------------------------------------------------------------------------------------------------------------------------------------------------------------------------------------------------------------------------------------------------------------------------------------------------------------------------------------------------------------------------------------------------------------------------------------------------------------------------------------------------------------------------------------------------------------------------------------------------------------------------|---------------------------------------------------------------------------------------------------------------------------------------------------------------------------------------------------------------------------------------------------------------------------------------------------------------------------------------------------------------------------------------------------------------------------------------------------------------------------------------------------------------------------------------------------------------------------------------------------------------------------------------------------------------------------------|
| I. CLASSIFICATION OF SUBJECT MATTER (if several classification symbols apply, indicate all) ⁶ | | | | |
| According to International Patent Classification (IPC) or to both National Classification and IPC IPC: G 02 F 1/133 | | | | |
| II. FIELDS SEARCHED | | | | |
| Minimum Documentation Searched ⁷ | | | | |
| Classification System | Classification Symbols | | | |
| IPC5 | G 02 F | | | |
| Documentation Searched other than Minimum Documentation to the Extent that such Documents are Included in Fields Searched ⁸ | | | | |
| SE,DK,FI,NO classes as above | | | | |
| III. DOCUMENTS CONSIDERED TO BE RELEVANT⁹ | | | | |
| Category * | Citation of Document, ¹¹ with indication, where appropriate, of the relevant passages ¹² | Relevant to Claim No. ¹³ | | |
| X | Applied Physics Letters, Vol. 51, No. 9, August 1987 (New York) G. Andersson et al: "Submicrosecond electro-optic switching in the liquid-crystal smectic A phase: The soft-mode ferroelectric effect ", see page 640 - page 642 especially page 640, line 1 - line 17 | 1 | | |
| A | -- | 2-19 | | |
| P,X | Journal of Applied Physics, Vol. 66, No. 10, November 1989 (New York) G. Andersson et al: "Device physics of the soft-mode electro-optic effect ", see page 4983 - page 4995 | 1-19 | | |
| X | US, A, 4725129 (KONDO ET AL) 16 February 1988, see column 1, line 33 - line 68 | 1-2,4 | | |
| <table style="width: 100%; border: none;"> <tr> <td style="width: 50%; border: none; vertical-align: top;"> <p>* Special categories of cited documents:¹⁰</p> <p>"A" document defining the general state of the art which is not considered to be of particular relevance</p> <p>"E" earlier document but published on or after the international filing date</p> <p>"L" document which may throw doubts on priority claim(s) or which is cited to establish the publication date of another citation or other special reason (as specified)</p> <p>"O" document referring to an oral disclosure, use, exhibition or other means</p> <p>"P" document published prior to the international filing date but later than the priority date claimed</p> </td> <td style="width: 50%; border: none; vertical-align: top;"> <p>"T" later document published after the international filing date or priority date and not in conflict with the application but cited to understand the principle or theory underlying the invention</p> <p>"X" document of particular relevance, the claimed invention cannot be considered novel or cannot be considered to involve an inventive step</p> <p>"Y" document of particular relevance, the claimed invention cannot be considered to involve an inventive step when the document is combined with one or more other such documents, such combination being obvious to a person skilled in the art.</p> <p>"&" document member of the same patent family</p> </td> </tr> </table> | | | <p>* Special categories of cited documents:¹⁰</p> <p>"A" document defining the general state of the art which is not considered to be of particular relevance</p> <p>"E" earlier document but published on or after the international filing date</p> <p>"L" document which may throw doubts on priority claim(s) or which is cited to establish the publication date of another citation or other special reason (as specified)</p> <p>"O" document referring to an oral disclosure, use, exhibition or other means</p> <p>"P" document published prior to the international filing date but later than the priority date claimed</p> | <p>"T" later document published after the international filing date or priority date and not in conflict with the application but cited to understand the principle or theory underlying the invention</p> <p>"X" document of particular relevance, the claimed invention cannot be considered novel or cannot be considered to involve an inventive step</p> <p>"Y" document of particular relevance, the claimed invention cannot be considered to involve an inventive step when the document is combined with one or more other such documents, such combination being obvious to a person skilled in the art.</p> <p>"&" document member of the same patent family</p> |
| <p>* Special categories of cited documents:¹⁰</p> <p>"A" document defining the general state of the art which is not considered to be of particular relevance</p> <p>"E" earlier document but published on or after the international filing date</p> <p>"L" document which may throw doubts on priority claim(s) or which is cited to establish the publication date of another citation or other special reason (as specified)</p> <p>"O" document referring to an oral disclosure, use, exhibition or other means</p> <p>"P" document published prior to the international filing date but later than the priority date claimed</p> | <p>"T" later document published after the international filing date or priority date and not in conflict with the application but cited to understand the principle or theory underlying the invention</p> <p>"X" document of particular relevance, the claimed invention cannot be considered novel or cannot be considered to involve an inventive step</p> <p>"Y" document of particular relevance, the claimed invention cannot be considered to involve an inventive step when the document is combined with one or more other such documents, such combination being obvious to a person skilled in the art.</p> <p>"&" document member of the same patent family</p> | | | |
| IV. CERTIFICATION | | | | |
| Date of the Actual Completion of the International Search | Date of Mailing of this International Search Report | | | |
| 3rd May 1990 | 1990 -05- 16 | | | |
| International Searching Authority | Signature of Authorized Officer | | | |
| SWEDISH PATENT OFFICE |  Roland Landström | | | |

| III. DOCUMENTS CONSIDERED TO BE RELEVANT (CONTINUED FROM THE SECOND SHEET) | | |
|----------------------------------------------------------------------------|-------------------------------------------------------------------------------------------------------------------------------------------------------------------------------------|----------------------|
| Category * | Citation of Document, with indication, where appropriate, of the relevant passages | Relevant to Claim No |
| X | US, A, 4729642 (KANEKO) 8 March 1988, see column 11, line 24 - column 12, line 26 -- | 1-2,4 |
| X | Ferroelectrics, Volume, Vol. 84, 1988 (New York) G. Andersson et al: "The Soft-Mode Ferroelectric effect ", see page 285 - page 315 especially page 285 - page 287, line 3 | 1 |
| A | -- ----- | 2-19 |

**ANNEX TO THE INTERNATIONAL SEARCH REPORT
ON INTERNATIONAL PATENT APPLICATION NO.PCT/SE 90/00109**

This annex lists the patent family members relating to the patent documents cited in the above-mentioned international search report. The members are as contained in the Swedish Patent Office EDP file on **90-03-30**.
The Swedish Patent Office is in no way liable for these particulars which are merely given for the purpose of information.

| Patent document cited in search report | Publication date | Patent family member(s) | Publication date |
|----------------------------------------|------------------|-------------------------|------------------|
| US-A- 4725129 | 88-02-16 | EP-A- 0173246 | 86-03-05 |
| | | JP-A- 61052630 | 86-03-15 |
| US-A- 4729642 | 88-03-08 | DE-A- 3401073 | 84-07-19 |
| | | GB-A-B- 2136185 | 84-09-12 |
| | | JP-A- 59129837 | 84-07-26 |
| | | US-A- 4548476 | 85-10-22 |