

(21) Application No 9214022.7

(22) Date of Filing 01.07.1992

(71) Applicant(s)
John Bruce Clayfield Davies
1 Mansfield Court, LIVINGSTON VILLAGE,
West Lothian, EH54 7BJ, United Kingdom

(72) Inventor(s)
John Bruce Clayfield Davies

(74) Agent and/or Address for Service
Cruikshank & Fairweather
19 Royal Exchange Square, GLASGOW, G1 3AE,
United Kingdom

(51) INT CL⁵
A61B 17/58 , F16B 7/04

(52) UK CL (Edition M)
A5R RFB RX4
F2G GRX GR1
U1S S1067

(56) Documents Cited
GB 1486701 A FR 002653006 A1 US 4492226 A

(58) Field of Search
UK CL (Edition L) A5R RFB
INT CL⁵ A61B , F16B 7/04
ONLINE DATABASES: WPI

(54) Securing devices for tubular members/ bone portions

(57) The device, which may be an intramedullary bone portion securing device for use with a fracture of the humerus or femur, comprises a rod (2) for receipt within the elongate cavity of the bone and provided with at least two expansion devices mounted to grip wall portions of the cavity at locations, on each side of the fracture site. The devices comprise slits formed in a sleeve (4) surrounding the rod so that an end surface (16) abuts a flange on the rod, tightening of a nut (20) causing the slits to distort. The sleeve may be in portions (4a, 4b) securable together so as to avoid relative rotational movement there between and between the portions and rod. Spacer means is provided between adjacent sleeve portions to allow adjustment of the distance between the expansion devices. The securing device may also be used to unite the end portions of tubular members of metal or plastics.

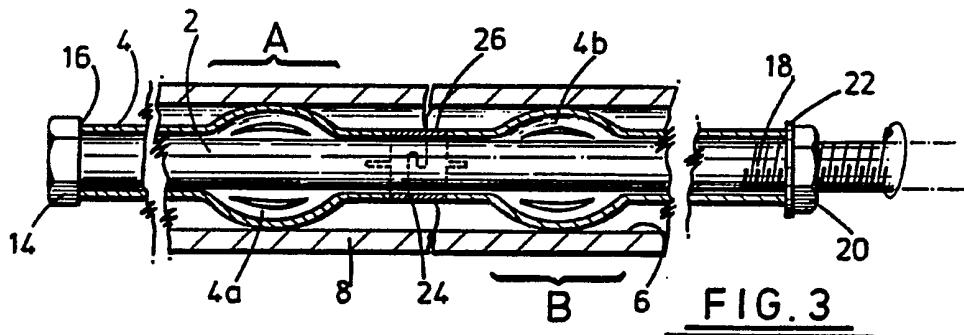

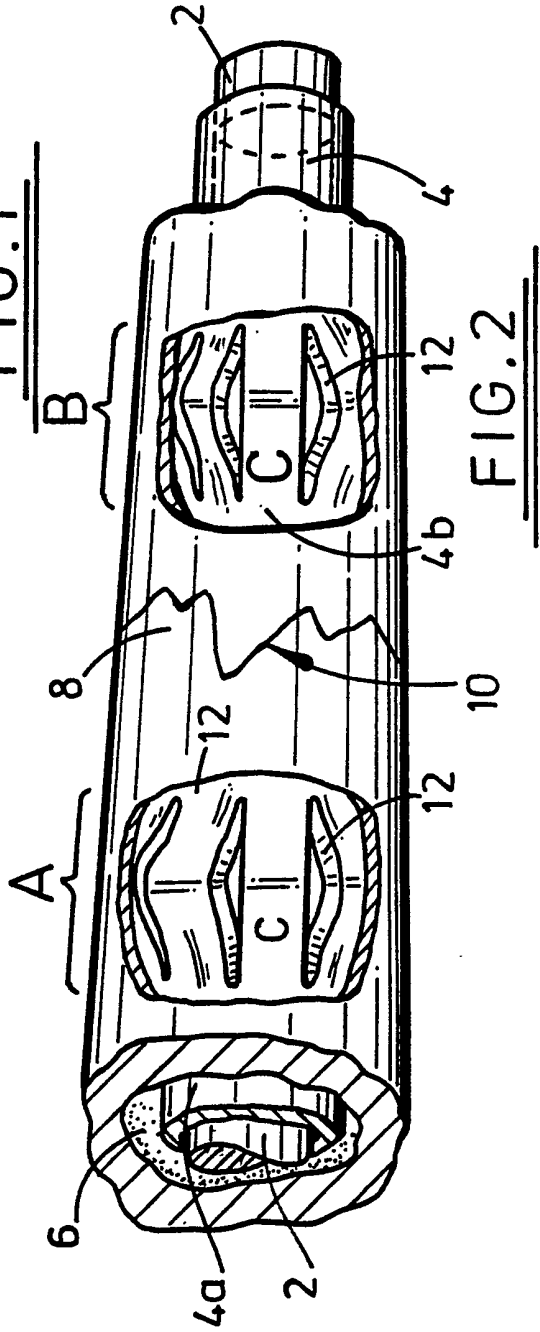
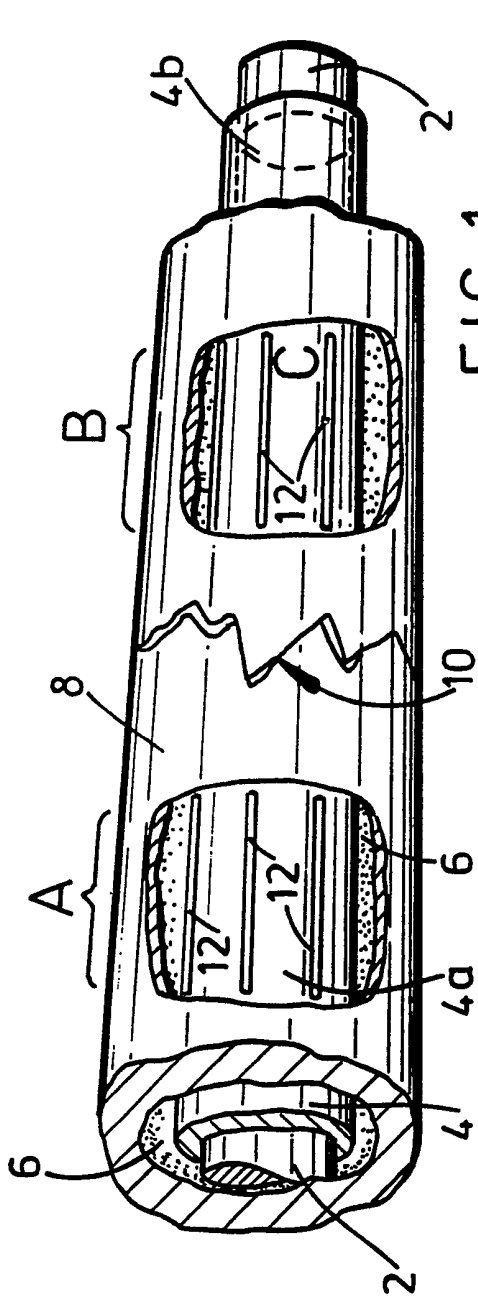

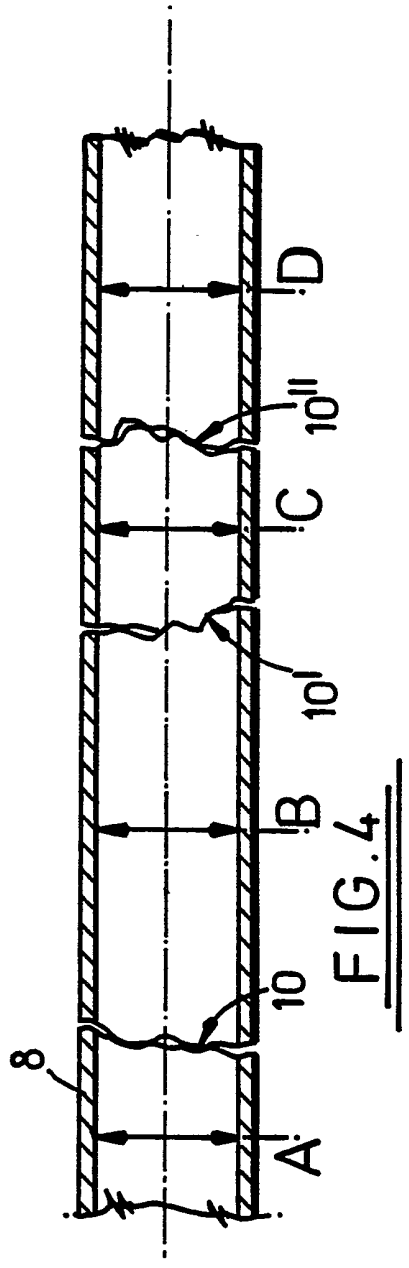
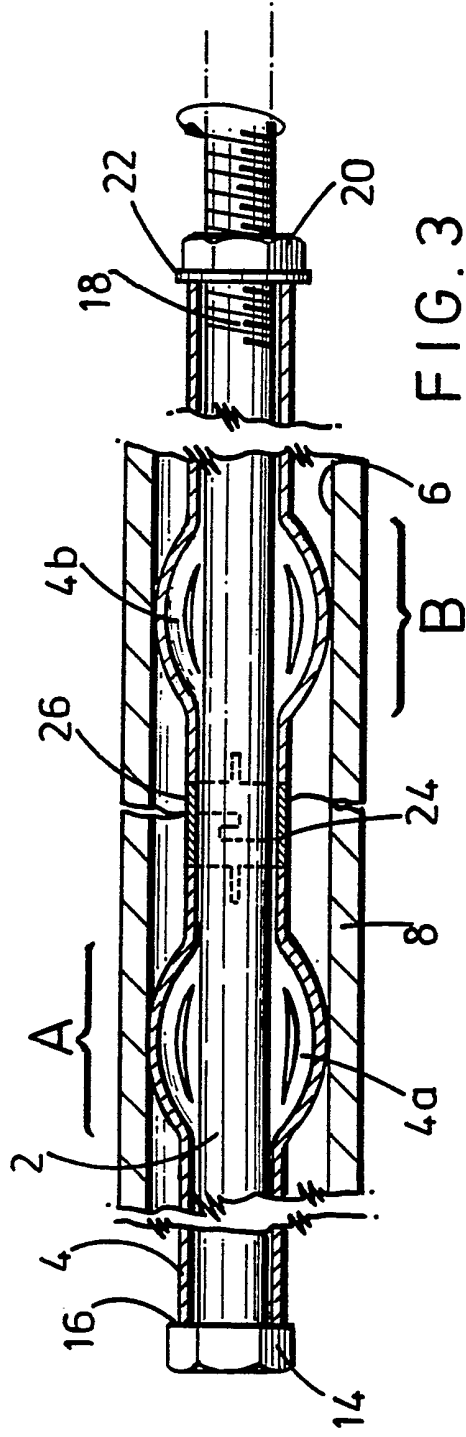

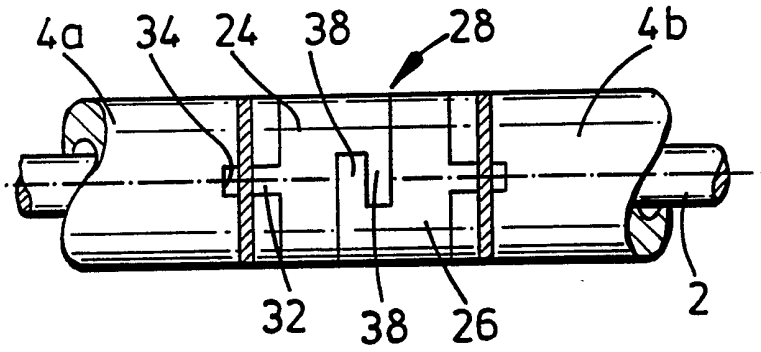

FIG. 5

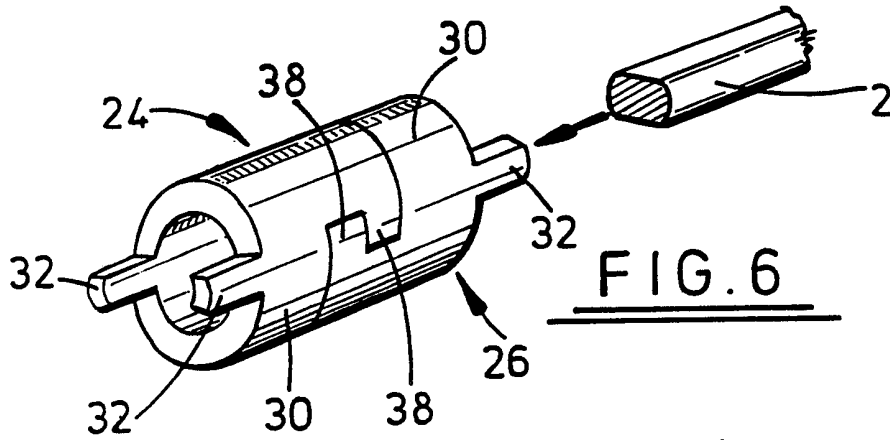

FIG. 6

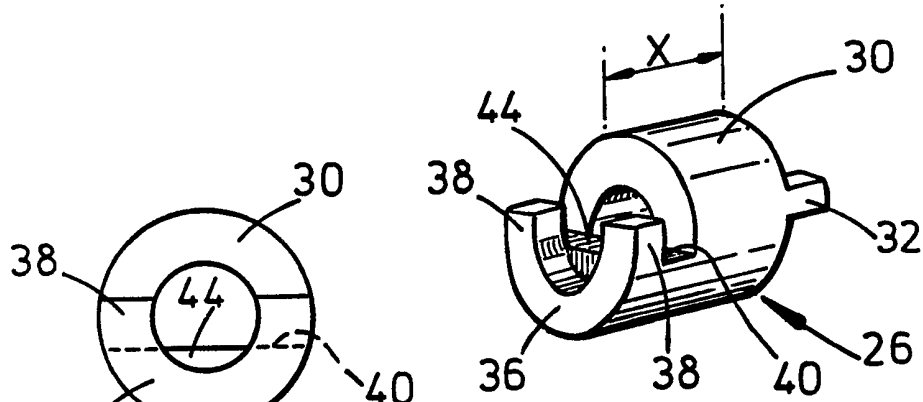

FIG. 7

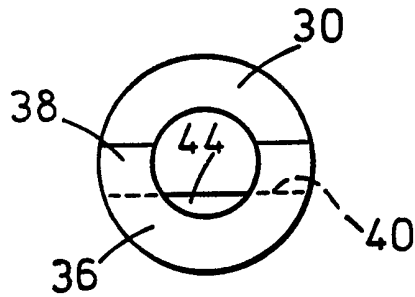

FIG. 8

SECURING DEVICES

The invention is concerned with improvements in or relating to securing devices. While the devices are particularly but not exclusively suitable for use in uniting and securing end portions of tubular members such as bones, they may be found useful in the context of tubular members of other rigid material such as metal, plastics and the like.

In the context of uniting fractured bone portions or bridging sound bone portions with replacement parts, a particular problem is that of bone fractures which require the use of intramedullary nails which are received in the marrow canal and secured in place by transverse pins. Corrosion, localised stresses and a lack of opportunity both for accurate initial positioning and for ease of later component removal, renewal or replacement, are but a few of the disadvantages associated with the use of conventional nails.

The present invention provides, according to one of its several aspects, a securing device for engagement with an interior cavity within a tubular member so as to link said tubular member with a second member, comprising rod or strut means, at least two expansion devices mounted in tandem upon the rod or strut means at zones spaced apart by an adjustable distance, actuating means being provided in association with said expansion devices to bring about increased dimensions thereof transversely of the tubular

member.

In examples of use of a device according to the invention and described later in this specification, the rod or strut means may be rigid. Conveniently, the rod or strut means may be as fully enclosed as is possible or practical within the tubular members, end portions of which abut or closely confront one another.

The invention further provides, according to another of its several aspects, an intramedullary bone portion securing device comprising rod means adapted to be received within a lengthwise extending bone cavity, at least two expansion devices mounted in tandem in association with the rod at spaced apart zones thereof, means to adjust and vary the distance between said zones, actuating means adapted to apply compressive force to said expansion devices to increase transverse dimensions thereof whereby to grip wall portions of said cavity, the construction and arrangement being that in use at least one expansion device is positioned within one bone portion and at least a second device is positioned within a second bone portion so as to secure said portions in an at least substantially rigid manner about said rod.

Conveniently, at least two expansion devices are incorporated in longitudinally spaced apart areas of a sleeve means through which said rod axially passes, an anchor portion of said sleeve means being secured to said rod so as to prevent axial movement with respect thereto

in the area of the anchor portion, said actuating means being arranged to apply said compressive force at a rod zone spaced from the anchor portion to cause the intervening expansion devices to deform to increase the effective diameter of the sleeve at the location of said expansion devices.

Advantageously, the actuating means may comprise means to reduce the overall effective length of the rod within the sleeve means.

In examples of the devices, each expansion device may comprise a plurality of longitudinal slits formed around a wall portion of the sleeve means. Conveniently the sleeve means may comprise a plurality of sleeve portions arranged end-to-end about the rod with spacer means provided between adjacent sleeve portions to allow adjustment of the distance between sleeve portions and the overall length of the device.

Intramedullary devices as referred to above may conveniently be used in the setting of bone fractures, being particularly useful in the case of long bones for example, a femur humerus, radius or ulna. Such sites entail difficulties where the bone is required to be held in place, since these bones are usually surrounded by a considerable thickness of muscle, which spaces a rigid support of plaster of paris from the bone by a distance which is too great to ensure that the bone is accurately aligned and firmly held. Moreover, when the arm or leg is

in use, there may be rotary movement of the limb which could result in relative rotary movement between the sleeve portions. The present invention therefore provides a securing device as described above having an insert between adjacent sleeve portions comprising two connector portions one secured to each of said sleeve portions, the two connector portions being interengageable in a non-rotatable manner and attached in a fixed non-rotatable manner to the rod or strut portions. Preferably the two portions engage with a movement in a plane of their diameters.

It is not uncommon for there to be more than one site of fracture in a long bone. Moreover, the fracture may involve splintering or fragmentation of the bone such that the overall length may be difficult to maintain whilst the bone is healing, resulting in a shortened limb. In the use of devices according to the present invention, the overall length of the bone may be maintained where the rod or strut means extends rigidly between two expansion devices. It will be appreciated that the expansion devices are capable of gripping even a small region of the bone cavity wall provided there is at least a narrow, complete circumferential zone of undamaged bone at a reasonable location on each side of a fracture or between areas of damage in a double fracture. Thus in the latter mentioned circumstances a single rod may be received within the bone, engaging the intramedullary cavity walls

at intervals, the rod holding the bone as an integral member and maintaining its desired length. It will be understood therefore that the opportunity may be taken, if desired, to adjust or correct any bone length discrepancy.

It will be appreciated that the use of the connectors of the invention provide means by which a tensile load may be transmitted from one sleeve to the next to that when the device is to be removed the arrangement aids the collapse of the expansion devices.

There will now be described an example of one securing device according to the present invention. It will be understood that the description, which is to be read with reference to the drawings, is given by way of example only and not by way of limitation.

In the drawings:-

Figure 1 shows a fragmentary perspective view of a securing device for use with bone fractures and according to the invention, including expansion devices in an unexpanded condition;

Figure 2 shows the securing device of Figure 1 the expansion device having been actuated;

Figure 3 shows a similar arrangement to that of Figures 1 and 2 and including a spacer means;

Figure 4 is a diagrammatic representation of a device as shown in the Figures, adapted to deal with a multiple fracture;

Figure 5 is a fragmentary side view of a connector or

joining device having a rotation-resisting arrangement;

Figure 6 is a perspective view of the connector of Figure 5;

Figure 7 is a perspective view of a portion of the connector; and

Figure 8 is an end view of the connector.

The securing device as shown in Figures 1 and 2 comprises a rod 2 which passes through a sleeve member 4 formed of stiffly resilient plastics material. The sleeve member 4 comprises two portions 4a and 4b for reasons to be explained below. The device is shown received in the marrow channel or cavity 6 of a bone 8, which in the present example is a mammalian humerus. The bone is shown with a fracture at 10 which requires the portions of the bone 8 to be re-united.

Expansion devices are provided in the sleeve member 4 by forming a plurality of longitudinal slots 12 in a group at each of two areas A and B of the sleeve member, the bone 8 having been drawn broken-away at those areas for clarity.

In order for the effective diameter of the expansion devices to be brought about in order to achieve gripping contact with the wall of the bone cavity 6, compressive force must be applied axially of the sleeve so as to force the slots 12 to open, due to the reduced resistance to deformation of the sleeve in the region of the slots. The opened slots can be seen in Figure 2, where the portions C

of the sleeve 4a are outwardly bowed into the required gripping contact.

One example of a means for actuating the expansion devices in Figures 1 and 2 is shown in Figure 3, in which the rod 4 is provided with a radial flange 14 at one end thereof against which flange abuts an annular end surface 16 of the sleeve. The opposite end of the rod is provided with a screw-threaded portion 18 on which is received a nut 20 and washer 22. The opposite end surface of the rod 2 abuts the washer which, when the nut is turned, bears against the captive sleeve 4 and applies the required compressive force. Although Figure 3 is a schematic view, it will be appreciated that a number of suitable methods by which the nut may be turned will be available to the surgeon or veterinary practitioner. Access to the operating component will normally be through the end portion (not shown) of the bone 8; in the case of the humerus, this may be the area immediately adjacent the elbow joint.

Figure 3 illustrates the two-part construction of the sleeve 4 to accommodate a requirement for varying distances to be provided between the areas A and B. Each portion, 4a and 4b, is secured to one of two interengageable annular portions 24, 26 of a joining device 28 (see also Figures 5 to 8) adapted to connect together the portions 4a and 4b in a manner to prevent inadvertent relative rotary movement through use of the

limb during healing of the bone. Each portion 24, 26 comprises a cylindrical member 30 having two projections 32 extending from one annular end surface thereof and fixedly engageable in a pair of slots 34 in the sleeve portions 4a and 4b, respectively. Extending from the opposite end surface of each member 30 is a part cylindrical extension 36, having two circumferentially extending lugs 38 each of which partially defines a recess 40. The two portions 24, 26 are interengaged by bringing them together in a transverse movement with respect to the axis of the cylindrical members 30 so that the lugs 38 of one portion are received in the recess 40 of the other portion. The rod 2 then passes through the connecting members but is itself prevented from rotation relative to the connecting members by the provision of a flat 42 on the rod 2 which engages in a bridge portion 44 of the connector member 26 as shown in Figures 7 and 8. Thus any tendency for unwanted rotational movement is suppressed.

The axial dimension of member 30 may be selected from a range of dimensions in order to provide the required distance between the two areas A and B. The portions 24 and 26 are assembled with the sleeve portion 4a and 4b on the rod 2, prior to insertion in the bone, the or each set of components being slid into the rod 2 to result in the required overall dimensions.

Figure 4 illustrates a diagrammatic layout of four areas where expansion device such as the slots 12 of

sleeve 4 are to be provided to accommodate a badly broken bone 8 which has a plurality of fractures 10, 10' and 10". Area B is thus situated between fractures 10 and 10', and area C between fractures 10' and 10", areas A and D being outwith or beyond the region of damage. It will be appreciated that there may well be gaps between bone edges at any of the fractures 10 but this is in no way detrimental to the operation of the securing device of the invention. Such gaps will in any case tend to fill in as the bone heals.

It will be appreciated that the use of a device according to the invention may be controlled to an appreciable degree by the manner in which the slotted portion of the sleeve members is formed. The extent of the deformation brought about by the application of compressive force in a longitudinal direction can be controlled by selection from a number of variables, e.g. number of slots in each annular group, thickness of sleeve wall, choice of material for the sleeve, width and/or length of the slots, width of sleeve area intervening between the slots and so on. Moreover, the deformation characteristics of the expansion devices may be selected to vary between two or more areas of the bone, so that selection expansion, sequentially arranged if desired, can be achieved.

It will also be understood that the cross section of the sleeve, although described above as being conveniently

circular, may be oval, triangular or rectangular or any convenient cross-section as desired.

In addition, as briefly referred to above, there is the facility now provided for adjustment of the device during the insertion thereof if required.

It is also possible to select the material of the sleeve so that it is degradable in time and does not require to be removed once the bone has healed. The rod means may be withdrawn from the bone through the access point, e.g. the elbow, at which actuation of the expansion devices was brought about

In the above description, the references to the expansion devices have been illustrated with respect to slotted sleeves, but it will be understood that the invention is not limited to this form of expansion device. Alternative forms may involve additional gripping surfaces, biasing means and if necessary, use of a camming action between part conical or wedge-shaped surfaces forming part of the expansion devices.

Various modifications may be made within the scope of the invention.

CLAIMS:

1. An intramedullary bone portion securing device comprising rod means adapted to be received within a lengthwise extending bone cavity, at least two expansion devices mounted in tandem in association with the rod at spaced apart zones thereof, means to adjust and vary the distance between said zones, actuating means adapted to apply compressive force to said expansion devices to increase transverse dimensions thereof whereby to grip wall portions of said cavity, the construction and arrangement being that in use at least one expansion device is position within one bone portion and at least a second device is positioned within a second bone portion so as to secure said portions in an at least substantially rigid manner about said rod.

2. A device according to claim 1, wherein at least two expansion devices are incorporated in longitudinally spaced apart areas of a sleeve means through which said rod axially passes, an anchor portion of said sleeve means being secured to said rod so as to prevent axial movement with respect thereto in the area of the anchor portion, said actuating means being arranged to apply said compressive force at a rod zone spaced from the anchor portion to cause the intervening expansion devices to

deform to increase the effective diameter of the sleeve at the location of said expansion devices.

3. A device according to claim 2, wherein the actuating means comprises means to reduce the overall effective length of the rod within the sleeve means.

4. A device according to any one of the preceding claims, wherein each expansion device comprises a plurality of longitudinal slits formed around a wall portion of the sleeve means.

5. A device according to any one of claims 1 to 3, wherein the expansion devices comprise portions including part-conical or wedge-shaped surfaces adapted to partake of a camming action therebetween.

6. A device according to any one of claims 1 to 3, wherein the expansion devices comprise additional gripping surfaces or biasing means.

7. A device according to any one of claims 2 to 4, wherein the sleeve means comprises a plurality of sleeve portions arranged end-to-end about said rod, spacer means being provided between adjacent sleeve portions to allow adjustment of the distance between sleeve portions and of the overall length of the device.

8. A device as claimed in claim 2, wherein said sleeve means comprises a plurality of sleeve portions arranged end-to-end about said rod, confronting end portions of said sleeves portions each being provided with a joining portion, said joining portion being interengageable with one another so as to prevent relative rotation between adjacent sleeve portions and between the sleeve portions and the rod.

9. A device as claimed in claim 8, wherein the joining portions engage with a transverse movement in a plane of their diameters.

10. A device as claimed in either one of claims 8 and 9, wherein said confronting end portions are provided on a two-part joining means, a first part of which is fixedly secured to one of said sleeve portions and a second part of which is fixedly secured to an adjacent one of said sleeve portions.

11. A device as claimed in claim 10, wherein said two-part joining means provides a spacer device between adjacent sleeve portions to allow adjustment of the distance between adjacent sleeve portions and of the overall length of the device.

12. A device as claimed in either one of claims 10 and 11, wherein said joining means comprise two hollow cylindrical members each having a part-cylindrical projection extending axially from an annular end surface thereof, each said extension having two circumferentially extending lugs each of which at least partially defines a recess, the construction and arrangement being such that the two members are interengaged when brought together in said transverse movement by the lugs of one portion being received in the recess of the other portion.

13. A device as claimed in claim 12, wherein a bridge portion is included in recess of each joining portion, said bridge portion including a flat surface formed on an arc of said cylindrical member, and wherein said rod is provided with two, opposed lengthwise extending flat surfaces arranged so as in use to abut respective ones of said bridge portion flat surfaces to prevent relative rotation therebetween.

14. A securing device for engagement with an interior cavity within a tubular member so as to link said tubular member with a second member, comprising rod or strut means, at least two expansion devices mounted in tandem upon the rod or strut means at zones spaced apart by an adjustable distance, actuating means being provided in

association with said expansion devices to bring about increased dimensions thereof transversely of the tubular member.

15. An intramedullary bone portion securing device constructed and arranged substantially as hereinbefore described with reference to and as shown in the drawings.

**Patents Act 1977
Examiner's report to the Comptroller under
Section 17 (The Search Report)**

Application number

GB 9214022.7

Relevant Technical fields

- (i) UK CI (Edition L) A5R (RFB)
- (ii) Int CI (Edition 5) A61B, F16B 7/04

Search Examiner

L V THOMAS

Databases (see over)

- (i) UK Patent Office
- (ii) ONLINE DATABASE: WPI

Date of Search

28 SEPTEMBER 1993

Documents considered relevant following a search in respect of claims 1-15

Category (see over)	Identity of document and relevant passages	Relevant to claim(s)
X	GB 1486701 (AVILA) See lines 21-64 page 1	1, 14
X	FR 2653006 A1 (DORANGE) See line 29 page 1 - line 11 page 2, lines 8-16 page 4 - lines 4-16 page 8	1, 2, 6, 14
X	US 4492226 (BELYKH ET AL) See lines 26-42 column 2 and lines 4-46 column 3	1, 5, 14

--	--	--

Categories of documents

X: Document indicating lack of novelty or of inventive step.

Y: Document indicating lack of inventive step if combined with one or more other documents of the same category.

A: Document indicating technological background and/or state of the art.

P: Document published on or after the declared priority date but before the filing date of the present application.

E: Patent document published on or after, but with priority date earlier than, the filing date of the present application.

&: Member of the same patent family, corresponding document.

Databases: The UK Patent Office database comprises classified collections of GB, EP, WO and US patent specifications as outlined periodically in the Official Journal (Patents). The on-line databases considered for search are also listed periodically in the Official Journal (Patents).