

⑫

EUROPEAN PATENT APPLICATION

⑰ Application number: 88115194.8

⑤① Int. Cl.4: **B05C 21/00** , **B32B 27/00** ,
B05D 1/32

⑱ Date of filing: 16.09.88

⑳ Priority: 18.09.87 JP 143498/87 U
18.09.87 JP 143499/87 U
18.09.87 JP 143500/87 U
18.09.87 JP 143501/87 U
07.04.88 JP 47328/88 U
18.04.88 JP 51693/88 U

㉓ Date of publication of application:
22.03.89 Bulletin 89/12

㉔ Designated Contracting States:
DE FR GB IT SE

㉖ Applicant: **NAGOYA OILCHEMICAL CO., LTD.**
213-5 Honowari Minamishibata-cho
Tokai Aichi(JP)

㉗ Inventor: **Horiki, Seinosuke**
c/o Nagoya Oilchemical Co., Ltd. 213-5
Honowari
Minamishibata-cho Tokai-shi Aichi(JP)
Inventor: **Makino, Reiji**
c/o Nagoya Oilchemical Co., Ltd. 213-5
Honowari
Minamishibata-cho Tokai-shi Aichi(JP)

㉙ Representative: **Vossius & Partner**
Siebertstrasse 4 P.O. Box 86 07 67
D-8000 München 86(DE)

⑤④ **A masking member.**

⑤⑦ A new masking member (100) consisting of a laminated sheet which comprises a polystyrene foam sheet (101X) and thermoplastic film(s) (101Y) laminated on one or both side(s) of said polystyrene foam sheet. Said polystyrene foam sheet is reinforced by said thermoplastic film(s) and also protected by said thermoplastic film(s) from an organic solvent.

FIG. 1

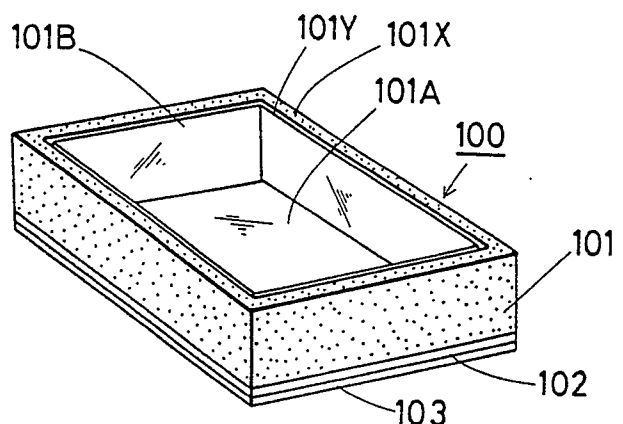

EP 0 307 932 A1

A MASKING MEMBER

BACKGROUND OF THE INVENTION

The present invention relates to a new masking member which protects the necessary part(s) of an article from a surface treatment, such as coating, plating, vacuum evaporation, and the like. The masking member may be attached on the even surfaces of the article to be protected by an adhesive layer formed on said masking member, or said masking member may be attached to the holes of the article to be protected by inserting said masking member into said holes, or said masking member may be attached to the panel-like parts of the article by inserting said panel-like parts into a slit formed from an end of said masking member. Masking members thus attached to the parts of the article to be protected may be removed respectively from said parts after surface treatment. Accordingly, from the viewpoint of the rationalization of the surface treatment process, it may be important how said masking members are easily attached to said parts before said surface treatment and how said masking members are easily removed from said parts after said surface treatment. Especially, said ease of attaching and removing said masking members to/from said parts of the article may be very significant in the mass producing process, such as the coating line of the automobile industry or the house hold electric furnishings industry. Further, the masking member will not be swelled or dissolved by/in an organic solvent or an agent used in the surface treatment, to protect completely the part of the article to which the masking member is attached from said surface treatment. Still further, the masking member will not be broken during transportation, storing, handling, or the like. Still further, since the masking member may be abandoned after use, the material cost and the production expense of the masking member will be inexpensive.

DESCRIPTION OF THE PRIOR ART

Hitherto, the inventors of the present invention have proposed masking members consisting of a polystyrene foam sheet (USSN 061,700, USSN 100,524, USSN 101,689). Said polystyrene foam sheet, what is called polystyrene paper, may be very suitable for the material of a masking member since said polystyrene foam sheet is inexpensive and easily molded by such as vacuum forming and the like. Said masking member consisting of said polystyrene foam sheet may be removed by em-

ploying a hook or by heating. Since said polystyrene foam is one of the most brittle of plastic foams, a hook may be easily stuck into said masking member consisting of said polystyrene foam sheet. Further, since said polystyrene foam sheet of said masking member has a closed cell, when said masking member is heated at a higher temperature than its softening point, air and blowing gas in said closed cell may expand and simultaneously the masking member may also expand, and then said expanding air and blowing gas will break said closed cell and said air and blowing gas will escape from said closed cell and as the result, the masking member may shrink. Thus, when said masking member is heated at a higher temperature than the softening point of said polystyrene foam sheet of said masking member, said masking member may first expand and then shrink, and when said masking member expands, close contact between said masking member and the part of the article to which said masking member is attached may become loose and as the result, when said masking member shrinks, the removing of said shrunk masking member from said part may be very smooth without the sticking of said softened shrunk masking member to said part. Accordingly, a masking member consisting of said polystyrene foam sheet can be provided at a low price and said masking member is very easily attached and removed to/from a part of the article to be protected from surface treatment.

SUMMARY OF THE INVENTION

Accordingly, an object of the present invention is to provide a masking member at a low price. Another object of the present invention is to protect the masking member from being broken during transportation, storing, handling or the like. A further object of the present invention is to protect the masking member from an organic solvent used in the surface treatment. A still further object of the present invention is to provide a masking member which is easily attached and removed to/from the part of the article to be protected.

According to the present invention, there is provided a masking member consisting of a laminated sheet which comprises a polystyrene foam sheet and thermoplastic film(s) laminated on one or both side(s) of said polystyrene foam sheet. Said thermoplastic film may be the film of a thermoplastic resin such as polyethylene, polypropylene, polyvinylchloride, polyamide, polystyrene and the like, and a high-impact polystyrene is one of the desir-

able thermoplastic resins since the price of said high-impact polystyrene is low. Of course, said high-impact polystyrene is dissolved in an organic solvent, such as toluene, ethyl acetate, and the like but said high-impact polystyrene has better resistance against an organic solvent than said polystyrene foam and said high-impact polystyrene film may protect completely said polystyrene foam sheet from the poorer solvents of polystyrene, such as methanol, ethanol, and the like, and further, said high-impact polystyrene film may protect said polystyrene foam sheet from the strong solvents of polystyrene, such as toluene, ethyl acetate and the like in a short exposure of said strong solvents. Said thermoplastic film may be laminated on one or both side(s) of said polystyrene foam sheet when said polystyrene foam sheet is produced by extrusion foaming, or after said polystyrene foam sheet is produced by extrusion foaming, such as when said polystyrene foam sheet is molded by vacuum forming. Commonly, said thermoplastic film is attached to said polystyrene foam sheet by heating or by using an adhesive. In said laminated sheet, the expansion ratio of said polystyrene foam sheet may be commonly from 2 to 50 times and desirably from 7 to 20 times and the thickness of said sheet may be 0.5 to 7 mm, and the thickness of said thermoplastic film may be 0.001 to 1 mm.

The masking member of the present invention may be produced by vacuum forming, pressing, blow-molding, cutting, and the like from said laminated sheet and if desirable, an adhesive layer may be formed partially or wholly on the surface of said masking member. Said adhesive layer may be formed by coating an adhesive on said surface of said masking member and drying said coated adhesive. It is desirable to use an emulsion type adhesive since said emulsion type adhesive does not make said polystyrene foam sheet of said masking member swell or dissolve and it is desirable to add a water soluble polymer in said emulsion type adhesive to increase cohesion of said adhesive (USSN 001,822). In the case where cohesion of said adhesive is increased by adding said water soluble polymer, said water soluble polymer may prevent transfer of said adhesive to the part of the article to which the masking member has been attached when said masking member is removed from said part.

Said masking member of the present invention may be used in the coating process of the automobile industry such as the coating of a car body, the coating of bumpers, the corrosion, sound, and vibration-proof treatment of the underside of a car body by using a viscoelastic material such as polyvinylchloride sol, polyurethane, tar-polyurethane, and the like, and also said masking member of the present invention may be used in the coating pro-

cess of the house hold electric furnishings industry, such as the coating of electric refrigerators, televisions, and the like.

Further, said masking member of the present invention is used not only in the coating process, but also for other surface treatment, such as plating, vacuum evaporation, and the like.

BRIEF DESCRIPTION OF THE DRAWINGS

Figure 1 is a perspective view of a first embodiment of the present invention.

Figure 2 is a partial side sectional view of the first embodiment of the present invention after coating.

Figure 3 is a partial side sectional view of the first embodiment of the present invention in the case of removing the masking member from the article.

Figure 4 is a perspective view of a second embodiment of the present invention.

Figure 5 is a perspective view of a third embodiment of the present invention.

Figure 6 is a partial side sectional view of the third embodiment of the present invention after coating.

Figure 7 is a partial perspective view of the third embodiment of the present invention in the case of said third embodiment being produced.

Figure 8 is a perspective view of a fourth embodiment of the present invention.

Figure 9 is a perspective view of a fifth embodiment of the present invention.

Figure 10 is a perspective view of a sixth embodiment of the present invention.

Figure 11 is a side sectional view of the sixth embodiment of the present invention.

Figure 12 is a perspective view of a seventh embodiment of the present invention.

Figure 13 is a perspective view of an eighth embodiment of the present invention.

Figure 14 is a perspective view of a ninth embodiment of the present invention.

Figure 15 is a perspective view of a tenth embodiment of the present invention.

Figure 16 is a perspective view of an eleventh embodiment of the present invention.

Figure 17 is a perspective view of the eleventh embodiment of the present invention in the case of said first embodiment being produced.

Figure 18 is a partial side sectional view of the eleventh embodiment of the present invention after coating.

Figure 19 is a partial side sectional view of the eleventh embodiment of the present invention in the case of removing the masking member from the article.

Figure 20 is a partial side sectional view of the eleventh embodiment of the present invention in case of protection of a protruding part.

Figure 21 is a perspective view of a twelfth embodiment of the present invention.

Figure 22 is a partial side sectional view of the twelfth embodiment of the present invention after coating.

Figure 23 is a perspective view of a thirteenth embodiment of the present invention.

Figure 24 is a perspective view of a fourteenth embodiment of the present invention.

Figure 25 is a perspective view of a fifteenth embodiment of the present invention.

Figure 26 is a partial side sectional view of the fifteenth embodiment of the present invention after coating.

Figure 27 is a perspective view of a sixteenth embodiment of the present invention.

Figure 28 is a partial side sectional view of the sixteenth embodiment of the present invention after coating.

Figure 29 is a perspective view of the seventeenth embodiment of the present invention.

Figure 30 is a partial side sectional view of the seventeenth embodiment of the present invention.

Figure 31 is a partial side sectional view of the seventeenth embodiment of the present invention in the case of removing the masking member from the article.

Figure 32 is a perspective view of the eighteenth embodiment of the present invention.

Figure 33 is a partial side sectional view of the eighteenth embodiment of the present invention after coating.

Figure 34 is a perspective view of the nineteenth embodiment of the present invention.

Figure 35 is a perspective view of the twentieth embodiment of the present invention.

Figure 36 is a perspective view of the twenty-first embodiment of the present invention.

Figure 37 is a perspective view of the twenty-second embodiment of the present invention.

Figure 38 is a perspective view of the twenty-third embodiment of the present invention.

Figure 39 is a partial side sectional view of the twenty-third embodiment of the present invention after coating.

Figure 40 is a side sectional view of the twenty-fourth embodiment of the present invention.

Figure 41 is a perspective view of the twenty-fifth embodiment of the present invention.

Figure 42 is a perspective view of the twenty-sixth embodiment of the present invention.

Figure 43 is a perspective view of the twenty-seventh embodiment of the present invention.

Figure 44 is a perspective view of the twenty-eighth embodiment of the present invention.

Figure 45 is a perspective view of the twenty-ninth embodiment of the present invention.

Figure 46 is a partial side sectional view of the twenty-ninth embodiment after coating.

Figure 47 is a perspective view of the thirtieth embodiment of the present invention.

Figure 48 is a partial side sectional view of the thirtieth embodiment of the present invention.

Figure 49 is a perspective view of the thirty-first embodiment of the present invention.

Figure 50 is a partial side sectional view of the thirty first embodiment of the present invention.

Figure 51 is a perspective view of the thirty-second embodiment of the present invention.

Figure 52 is a perspective view of the thirty-third embodiment of the present invention.

Figure 53 is a partial side sectional view of the thirty-third embodiment after coating.

Figure 54 is a partial sectional view of the thirty-third embodiment in the case of removing the masking member from the article.

Figure 55 is a perspective view of the thirty-fourth embodiment of the present invention.

Figure 56 is a perspective view of a car body of a practical example of the present invention.

Figure 57 is a perspective view of Part A to be protected by the masking member of the practical example.

Figure 58 is a perspective view of Part B to be protected by the masking member of the practical example.

Figure 59 is a perspective view of Part C to be protected by the masking member of the practical example.

Figure 60 is a perspective view of Part D to be protected by the masking member of the practical example.

Figure 61 is a perspective view of Part E to be protected by the masking member of the practical example.

Figure 62 is a perspective view of a thirty-fifth embodiment of the present invention.

Figure 63 is a sectional view along a cutting line A-A in Figure 62.

Figure 64 is a partial perspective view of a bumper to which the masking member of the thirty-fifth embodiment is applied.

Figure 65 is a side sectional view of said bumper after coating.

Figure 66 is a side sectional view of said bumper in the case of removing the masking member from said bumper.

Figure 67 is a perspective view of a thirty-sixth embodiment of the present invention.

Figure 68 is a partial side sectional view of the thirty-sixth embodiment of the present invention.

DETAILED DESCRIPTION

[Masking member A]

Masking member A is used to protect the even surfaces of the article.

Figure 1 to Figure 3 relate to a first embodiment of the present invention. Referring now to Fig. 1 to Fig. 3, a masking member(100) comprises a body(101) having a vessel form consisting of a rectangular bottom(101A) and perpendicular walls(101B) which extend upwards from the perimeter of said bottom(101A), with said body(101) manufactured by vacuum forming of a laminated sheet consisting of a polystyrene foam sheet(101X) and a thermoplastic film(101Y). An adhesive layer(102) such as the pressure sensitive adhesive layer is formed on the under surface of said body (101) and said adhesive layer(102) is covered with a release sheet(103) such as a polyethylene film, a polypropylene film, a release paper and the like to prevent sticking to another article, the hands of workers and the like when the masking members are handled, one placed upon another, transported, and the like.

When said masking member(100) is used, said release sheet(103) is removed from said adhesive layer(102) and said masking member(100) is then attached to an even part(201) of the surface of an article(200) by said adhesive layer (102) thereof, which is necessary to be protected from a coating of viscoelastic material. After said masking member(100) is attached to said part(201), for instance a paint is coated on the surface of said article(200) by such as spraying, dipping and the like to form a coating layer(300) as shown in Figure 2. Said part(201) of said surface of said article(200) is not subjected to said coating since said part(201) is covered with said masking member(100) and said coating layer(300) may be cut by an edge(104) of the body(101) of said masking member(100). Said part(201) may have hole(s) and in this case, said hole(s) is(are) also not subjected to said coating. After said coated metal structure(200) is heated to dry and/or cure if desired and in cases where the heating temperature is adequately higher than the softening points of the polystyrene foam sheet (101X) and the thermoplastic film (101Y) of said body(101) of said masking member(100), said masking member(100) will firstly expand and then

shrink by said heating and come off by itself from said part(201) of said surface of said article(200) as shown in Fig. 3. As said masking member(100) comprises a body having a vessel form, the volume of said shrunk masking member(100) may be much smaller than the apparent volume of the unshrunk masking member(100) and further, as above described, said coating layer(300) may be cut by an edge(104) of the body(101) of said masking member(100), the removing of said masking member(100) from said part(201) of said article(200) may be very smooth without obstruction of said coating layer(300). Said masking member(100) may also be removed by a hook and, in this case, said masking member(100) may be easily removed without obstruction of said coating layer (300).

Figure 4 relates to a second embodiment of the present invention. In this embodiment, a masking member(110) comprises a body(111) having a vessel form consisting of a circular bottom(111A) and a perpendicular wall(111B) which extends upwards from the circumference of said bottom(111A), with said body(111) manufactured by vacuum forming of a laminated sheet consisting of a polystyrene foam sheet(111X) and a thermoplastic film(111Y) the same as the first embodiment of the present invention. An adhesive layer(112) is formed on the under surface of said body(111) and said adhesive layer(112) is covered with a release sheet(113) the same as the first embodiment of the present invention. Further, the body of said masking member of the present invention should have a suitable form according to the part to be protected from a surface treatment.

Figure 5 to Figure 7 relate to a third embodiment of the present invention. Referring now to Fig. 5 to Fig. 7, a masking member(120) comprises a body(121) having a vessel form consisting of a rectangular bottom(121A) and perpendicular walls(121B) which extend upwards from the perimeter of said bottom(121A), and a flange(122) which is extended from the upper edges of said walls(121B), with said body (121) manufactured by vacuum forming of a laminated sheet consisting of a polystyrene foam sheet(121X) and a thermoplastic film(121Y) the same as the first and second embodiments of the present invention. An adhesive layer(123) is formed on the under surface of said body(121) and said adhesive layer(123) is covered with a release sheet(124) the same as the first and second embodiments of the present invention.

When said masking member(120) is used, said release sheet(124) is removed from said adhesive layer(123) and said masking member(120) is then attached to a even part(221) of the surface of an article(220) which is necessary to be protected from a surface treatment. After said masking

member(120) is attached to said part(221), for instance, a paint is coated on said surface of said metal structure(220) to form a coating layer(320) as shown in Fig. 6. In this embodiment, said coating layer(320) may be more completely cut by said flange(122) of said masking member(120) than in the cases of the first and second embodiments of the present invention and, as the result, said masking member(120) may be more smoothly removed from said part(221) of said surface of said article(220).

A number of masking members(120) of this embodiment may advantageously be produced by vacuum forming from said laminated sheet as shown in Fig. 7. Referring to Fig. 7, a number of bodies(121) of masking members(120) are formed arranged in rows and lines, and each body(121) is connected to the other body(121) by the flange(122). Cutting lines (125) or grooves are formed between said flange(122) and another said flange(122) and when said masking member(120) is used, said masking member(120) is broken along said cutting lines(125) or grooves by hand. Said cutting lines(125) or grooves may be formed simultaneously with vacuum forming or after vacuum forming.

Figure 8 relates to a fourth embodiment of the present invention. In this embodiment a masking member(130) comprises a body(131) having a vessel form consisting of a rectangular bottom(131A) and perpendicular walls(131B) which extend upwards from the perimeter of said bottom (131A), a flange(132) which is extended from the upper edges of said walls(131B), and perpendicular walls(133) which extend upwards from the perimeter of said flange(132), with said body(131) manufactured by vacuum forming of a laminated sheet consisting of a polystyrene foam sheet(131X) and a thermoplastic film(131Y) the same as the first, second, and third embodiments of the present invention. An adhesive layer(134) is formed on the under surface of said body(131) and said adhesive layer(134) is covered with a release sheet(135) the same as the first, second, and third embodiments of the present invention. A surface treatment layer such as a coating layer may be more completely cut by said perpendicular walls(133) of said flange(132).

Figure 9 relates to a fifth embodiment of the present invention. In this embodiment, a masking member(140) comprises a body(141) having a vessel form consisting of a circular bottom(141A) and a perpendicular wall(141B) which extends upwards from the circumference of said bottom(141A), a flange(142) which is extended from the upper edges of said wall(141B), and perpendicular wall(143) which extends downwards from the circumference of said flange(142), with said body(141) manufactured by vacuum forming of a laminated

sheet consisting of a polystyrene foam sheet(141X) and a thermoplastic film(141Y) the same as the first, second, third and fourth embodiments of the present invention. An adhesive layer(144) is formed on the under surface of said body(141) and said adhesive layer(144) is covered with a release sheet(145) the same as the first, second, third, and fourth embodiments of the present invention.

Figure 10 and Figure 11 relate to a sixth embodiment of the present invention. In this embodiment, a masking member(150) comprises a body(151) having a vessel form consisting of a rectangular bottom(151A) from which a grip (152) is risen and perpendicular walls(151B) which extend upwards from the perimeter of said bottom(151A), with said body(151) made of a laminated layer consisting of a polystyrene foam sheet(151X) and a thermoplastic film(151Y) the same as the first, second, third, fourth, and fifth embodiments of the present invention. An adhesive layer(153) is formed on the under surface of said body(151) and said adhesive layer(153) is covered with a release sheet(154) the same as the first, second, third, fourth and fifth embodiments of the present invention. The masking member (150) of this embodiment is easily handled by holding said grip(152) of said masking member(150) when said masking member(150) is attached to an even part of the surface of an article which is to be protected from a coating and further, said masking member is easily removed by sticking said grip(152) of said masking member(150) with a hook.

Figure 12 relates to a seventh embodiment of the present invention. In this embodiment, a masking member(160) comprises a body(161) having a vessel form consisting of a circular bottom(161A) from which a grip(162) is risen and perpendicular wall which extend upwards from the circumference of said bottom(161A), with said body(161) manufactured by vacuum forming of a laminated sheet consisting of a polystyrene foam sheet(161X) and a thermoplastic film(161Y) the same as the first, second, third, fourth, fifth, and sixth embodiments of the present invention. An adhesive layer (163) is formed on the under surface of said body(161) and said adhesive layer(163) is covered with a release sheet (164) the same as the first, second, third, fourth, fifth, and sixth embodiments of the present invention.

Figure 13 relates to an eighth embodiment of the present invention. In this embodiment, a masking member(170) comprises a body(171) having a vessel form consisting of a rectangular bottom(171A) from which a grip(173) is risen and perpendicular walls(171B) which extend upwards from the perimeter of said bottom(171A), a flange(172) which is extended from the upper edges of said walls(171B), with said body(171) manufactured by

vacuum forming of a laminated sheet consisting of a polystyrene foam sheet(171X) and a thermoplastic film(171Y) the same as the prior embodiments of the present invention. An adhesive layer(174) is formed on the under surface of said body(171) and said adhesive layer(174) is covered with a release sheet(175) the same as the prior embodiments of the present invention.

Figure 14 relates to a ninth embodiment of the present invention. In this embodiment, a masking member(180) comprises a body(181) having a vessel form consisting of a rectangular bottom from which a grip(184) is risen and perpendicular walls(181B) which extend upwards from the perimeter of said bottom(181A), a flange(182) which is extended from the upper edges of said walls(181B), and perpendicular walls(183) which extend upwards from the perimeter of said flange(182), with said body(181) manufactured by vacuum forming of a laminated sheet consisting of a polystyrene foam sheet(181X) and a thermoplastic film (181Y) the same as the prior embodiments of the present invention. An adhesive layer(185) is formed on the under surface of said body(181) and said adhesive layer(185) is covered with a release sheet(186) the same as the prior embodiments of the present invention.

Figure 15 relates to a tenth embodiment of the present invention. In this embodiment, a masking member(190) comprises a body(191) having a vessel form consisting of a rectangular bottom(191A) from which a grip is risen and perpendicular walls(191B) which extend upwards from the perimeter of said bottom(191A), a flange(192) which is extended from the upper edges of said walls(191B), and perpendicular walls(193) which extend downwards from the perimeter of said flange(192), with said body(191) manufactured by vacuum forming of a laminated sheet consisting of a polystyrene foam sheet(191X) and a thermoplastic film(191Y) the same as the prior embodiments of the present invention. An adhesive layer(195) is formed on the under surface of said body(191) and said adhesive layer(195) is covered with a release sheet(196) the same as the prior embodiments of the present invention.

[Masking member B]

Masking member B is used to protect the even surface or the protruding part of the article.

Figure 16 to Figure 19 relate to an eleventh embodiment of the present invention. Referring now to Fig. 16 to Fig. 19, a masking member(1100) comprises a body(1101) having a vessel form consisting of a square bottom(1101A), perpendicular walls(1101B) which extend upwards from the pe-

rimeter of said bottom(1101A), a flange(1102) which is extended from the upper edges of said walls(1101B), and an adhesive layer(1103) formed on the surface of said flange (1102), with said masking member(1100) manufactured by vacuum forming of a laminated sheet consisting of a polystyrene foam sheet(1101X) and a thermoplastic film(1101Y). Said adhesive layer(1103) is covered with a release sheet (1104).

Said masking member(1100) may advantageously be produced by vacuum forming from said laminated sheet as shown in Fig. 17. Referring to Fig. 17, a number of masking members (1100) are formed and arranged in rows and lines, and each masking member(1100) is connected to the other masking member(1100) by the flange(1102). Cutting lines(1105) or grooves are formed between said flange(1102) and another said flange(1102) and when said masking member(1100) is used, said masking member(1100) is broken along said cutting lines(1105) or grooves by hand. Said cutting lines(1105) or grooves may be formed on the surface or (and) the under surface of said flange(1102). Referring to Fig. 18, when said masking member(1100) is used, said release sheet (1104) is removed from said adhesive layer(1103) and said masking member(1100) is then attached to an even part(2101) of the surface of an article(2100) by said adhesive layer (1103) thereof. After said masking member(1100) is attached to said part(2101), a surface treatment such as a coating is effected on the surface of said article(2100) to form a coating layer(3100). Said part(2101) of said surface of said article(2100) is not subjected to said coating since said part(2101) is covered with said masking member(1100). After said coating, said coated article(2100) is heated to dry and/or cure if desired and in cases where the heating temperature is adequately higher than the softening points of the polystyrene foam sheet(1101X) and the thermoplastic film(1101Y) of said body(1101) of said masking member(1100), said masking member(1100) will firstly expand and then shrink by said heating and come off by itself from said part(2101) of said surface of said metal structure(2100) as shown in Fig. 19. Said masking member(1100) is attached by only said adhesive layer(1103) on the surface of said flange(1102) thereof to said part(2101) of said article (2100), the removing of said masking member(1100) from said part(2101) of said article(2100) may be very smooth without obstruction of said adhesive layer(1103). Said masking member(1100) may also be removed by a hook and, in this case, said masking member(1100) may also be easily removed without obstruction of said adhesive layer(1103).

As shown in Figure 20, said masking member(1100) is also used to protect a protruding part-

(2102) of said metal structure(2100) by covering said protruding part(2102) with said masking member(1100).

Figure 21 and Figure 22 relate to a twelfth embodiment of the present invention. In this embodiment, a masking member(1110) comprises a body(1111) having a vessel form consisting of a circular bottom(1111A), an inner perpendicular wall(1111B) which extends upwards from the circumference of said bottom(1111A), a flange(1112) which is extended from the upper edge of said wall(1111B), and an outer perpendicular wall(1113) which extends downwards from the perimeter of said flange(1112), and an adhesive layer (1114) formed on the surface of said flange(1112), with said masking member(1110) manufactured by vacuum forming of a laminated sheet consisting of a polystyrene foam sheet (1111X) and a thermoplastic film(1111Y) the same as the prior embodiments of the present invention. Said adhesive layer(1114) is covered with a release sheet(1115) the same as the prior embodiments of the present invention

When said masking member(1110) is used, said release sheet(1115) is removed from said adhesive layer(1114) and said masking member(1110) is then attached to an even part (2111) as shown in Fig. 22, of the surface of an article (2110) by said adhesive layer(1114) thereof, and said part (2111) has a hole(2112). After said masking member(1110) is attached to said part(2111), a coating is effected on the surface of said metal structure(2110) to form a coating layer(3110). Said part(2111) including said hole (2112) is not subjected to said coating since said part (2111) is covered with said masking member(1110) and said coating layer(3110) may be cut by said outer perpendicular wall(1113) of said flange(1112) of said masking member (1110). After said coating, said coated article(2110) is heated to dry and/or cure if desired and in cases where the heating temperature is adequately higher than the softening points of the polystyrene foam sheet(1111X) and the thermoplastic film(1111Y) of said masking member(1110), said masking member(1110) will firstly expand and then shrink by said heating and come off by itself from said part(2111) of said surface of said article(2110). Since said coating layer(3110) may be cut by said outer perpendicular wall (1113) of said flange(1112) of said masking member(1110) as shown in Fig. 22, and said masking member(1110) is also attached by only said adhesive layer(1114) on the surface of said flange(1112) thereof to said part(2111) of said article(2110) the same as the eleventh embodiment of the present invention, the removing of said masking member (1110) from said part(2111) may be very smooth without obstruction of said coating layer(3110) and said adhe-

sive layer(1114) of said masking member(1110).

Figure 23 relates to a thirteenth embodiment of the present invention. In this embodiment, a masking member (1120) comprises a body(1121) having a vessel form consisting of a rectangular bottom(1121A) from which a grip(1123) is risen, perpendicular walls(1121B) which extend upwards from the perimeter of said bottom(1121A), a flange(1122) which is extended from the upper edges of said walls(1121B), and an adhesive layer(1124) formed on the surface of said flange(1122), with said masking member(1120) manufactured by vacuum forming of a laminated sheet consisting of a polystyrene foam sheet(1121X) and a thermoplastic film (1121Y) the same as the prior embodiments of the present invention, and said adhesive layer(1124) is covered with a release sheet(1125) the same as the prior embodiments of the present invention. The masking member(1120) of this embodiment is easily handled by holding said grip(1123) of said masking member(1120) when said masking member(1120) is attached to a part of the surface of an article which is to be protected from a coating and further, said masking member is easily removed by piercing said grip(1123) of said masking member(1120) with a hook.

Figure 24 relates to a fourteenth embodiment of the present invention. In this embodiment, a masking member (1130) comprises a body(1131) having a vessel form consisting of a circular bottom(1131A), from which a grip(1133) is risen, an inner perpendicular wall(1131B) which extends upwards from the circumference of said bottom(1131A), a flange(1132) which is extended from the upper edge of said wall(1131B), an outer perpendicular wall(1134) which extends downwards from the perimeter of said flange(1132), and an adhesive layer(1135) formed on the surface of said flange (1132) with said masking member(1130) manufactured by vacuum forming of a laminated sheet consisting of a polystyrene foam sheet(1131X) and a thermoplastic film(1131Y) the same as the prior embodiments of the present invention, and said adhesive layer(1135) is covered with a release sheet(1136) the same as in the prior embodiments of the present invention.

The masking member (1130) of this embodiment is easily handled by holding said grip(1133) of said masking member (1130) when said masking member(1130) is attached to a part of the surface of an article which is to be protected from a coating and further, said masking member(1130) may be easily removed by sticking said grip(1133) of said masking member(1130) with a hook.

Figure 25 and Figure 26 relate to a fifteenth embodiment of the present invention. In this embodiment, a masking member(1140) comprises a body(1141A) having a vessel form consisting of a

rectangular bottom(1141A), inner perpendicular walls(1141B) which extend upwards from the perimeter of said bottom(1141B), an upper flange(1142) which is extended from the upper edges of said walls(1141B), outer perpendicular walls(1143) which extend downwards from the perimeter of said upper flange(1142), a lower flange(1144) which is extended from the lower edges of said outer walls (1143), and an adhesive layer(1145) formed on the surface of said upper flange(1142) with said masking member(1140) manufactured by vacuum forming of a laminated sheet consisting of a polystyrene foam sheet(1141X) and a thermoplastic film(1141Y) the same as the prior embodiments of the present invention, and said adhesive layer(1145) is covered with a release sheet(1146) the same as the prior embodiments of the present invention.

The masking member(1140) may be attached to an even part(2141) of the surface of an article(2140) which is to be protected from a surface treatment such as a coating, and a coating layer(3140) may be more completely cut by said lower flange(1144) of said masking member(1140) than in the cases of the twelfth and fourteenth embodiments of the present invention since said lower flange(1144) of said masking member (1140) covers and protects the perimeter of said part(2141) of the surface of said article(2140) from said coating as shown in Fig. 26. Therefore, the removing of said masking member(1140) from said part(2141) may be more smooth than in the cases of the twelfth and fourteenth embodiments of the present invention.

Figure 27 and Figure 28 relate to a sixteenth embodiment of the present invention. In this embodiment, a masking member(1150) comprises a body(1151) having a vessel form consisting of circular bottom(1151A), an inner perpendicular wall(1151B) which extends upwards from the circumference of said bottom(1151A), an upper flange(1152) which is extended from the upper edge of said wall(1151B), a middle perpendicular wall(1153) which extends downwards from the circumference of said flange(1152), a lower flange(1154) which is extended from the lower edge of said middle perpendicular wall(1153), an outer perpendicular wall(1155) which extends upwards from the circumference of said flange(1154), and an adhesive layer(1156) formed on the surface of said upper flange(1152) with said masking member(1150) manufactured by vacuum forming of a laminated sheet consisting of a polystyrene foam sheet(1151X) and a thermoplastic film (1151Y) the same as the prior embodiments of the present invention, and said adhesive layer(1156) is covered with a release sheet(1157) the same as the prior embodiments of the present invention.

The masking member(1150) may be attached to an even part(2151) in the surface of an article(2150) which is to be protected from a surface treatment such as a coating, and a coating layer(3150) may be still more completely cut by said lower flange(1154) and said outer perpendicular wall(1155) than in the case of the fifteenth embodiment of the fifteenth embodiment of the present invention since the circumference of said part(2151) may be covered with both said lower flange(1154) and said outer perpendicular wall(1155) to protect said circumference of said part (2151) from said coating as shown in Fig. 28. Therefore, the removing of said masking member(1150) from said part (2151) may be more smooth than in the cases of the prior embodiments of the present invention.

[Masking member C]

Masking member C is used to protect the hole of the article.

Figure 29 to Figure 31 relate to the seventeenth embodiment of the present invention. Referring now to said figures, a masking member(1160) consists of an inserting part(1161) having a vessel form consisting of a circular bottom(1161A) and a perpendicular wall(1161B) which extends upwards from the circumference of said bottom(1161A), and a flange(1162) which is extended from the upper edge of said wall(1161B), said masking member(1160) manufactured by vacuum forming of a laminated sheet consisting of a polystyrene foam sheet(1161X) and a thermoplastic film(1161Y). Said inserting part(1161) has a taper form decreasing in diameter from the base of said inserting part(1161) to the top of said inserting part(1160).

When said masking member(1160) is used, said masking member(1160) protects the inside of a hole(2161) of an article(2160) by inserting said inserting part(1161) into said hole(2161) as shown in Fig. 30, and said flange(1162) of said masking member(1160) covers the surroundings(2162) of said hole(2161). After which, a coating is effected on the surface of said article(2160) to form a viscoelastic layer(3160) and the inside and surroundings of said hole (2161) are not subjected to said coating. After said coating, said masking member(1160) may be removed from said hole(2161) by hand, hook, and the like. Said masking member(1160) can be also removed from said hole(2161) by heating at a temperature higher than the softening points of the polystyrene foam sheet (1161X) and the thermoplastic film(1161Y). When said masking member(1160) is heated to said temperature, it may be softened and gases such as air, gas of a blowing agent, and the like in the cells of said polystyrene foam may firstly expand and so

said masking member may also expand and, then, when said gases leave the cells, said masking member(1160) may shrink rapidly and remove itself naturally from said hole(2161) as shown in Figure 31. After said masking member(1160) is removed from said hole (2161), said coating layer(3160) has not been formed inside and on said surrounding(2162) of said hole(2161) as shown in Fig. 31. Further, said masking member(1160) can be used for many holes having different diameters since said inserting part(1161) of said masking member(1160) has a taper form as before mentioned.

Figure 32 and Figure 33 relate to the eighteenth embodiment of the present invention. In this embodiment, a masking member(1170) consists of an inserting part(1171) having a vessel form consisting of a circular bottom(1171A) and a perpendicular wall(1171B) which extends upwards from the circumference of said bottom(1171A) and a flange(1172) which is extended from the upper part of said wall(1171B). Said inserting part(1171) has a taper form decreasing in diameter from the base of said inserting part(1171) to the top of said inserting part(1171). Said masking member(1170) is manufactured by vacuum forming of a laminated sheet consisting of a polystyrene foam sheet(1171X) and a thermoplastic film(1171Y).

Said masking member(1170) of this embodiment is used as same as the seventeenth embodiment and a coating layer (3170) may be cut by the upper edge of said inserting part(1171) as shown in Figure 33, and therefore, said masking member(1170) may be smoothly removed from the hole(2171) of the article(2170) without the obstruction of said coating layer(3170).

Figure 34 relates to the nineteenth embodiment of the present invention. In this embodiment, a masking member (1180) consists of an inserting part(1181) having a vessel form consisting of a circular bottom(1181A) and a perpendicular wall(1181B), and a flange(1182) which is extended from the upper edge of said wall(1181B). The width of said flange(1182) is smaller than the width of the flange(1162) of the masking member(1160) of the seventeenth embodiment and said flange(1182) having small width acts as a stopper of the masking member(1180) when said masking member(1180) is inserted into the hole. Said masking member (1180) is manufactured by vacuum forming of a laminated sheet consisting of a polystyrene foam sheet(1181X) and a thermoplastic film(1181Y).

Figure 35 relates to the twentieth embodiment of the present invention. In this embodiment, a masking member(1190) comprises an inserting part(1191) having a vessel form consisting of a circular bottom(1191A) from which a grip(1191C) is

risen, and perpendicular wall(1191B) which extends upwards from the circumference of said bottom(1191A), and a flange(1192) which is extended from the upper edge of said wall(1191B). Said inserting part (1191) has a taper form decreasing in diameter from the base of said inserting part(1191) to the top of said inserting part(1191). Said masking member(1190) is manufactured by vacuum forming of a laminated sheet consisting of a polystyrene foam sheet(1191X) and a thermoplastic film(1191Y). The masking member(1190) of this embodiment is easily handled by holding said grip(1191C) when said masking member (1190) is inserted into the hole of the metal structure or removed from the hole.

Figure 36 relates to the twenty-first embodiment of the present invention. In this embodiment, a masking member (1200) consists of an inserting part(201) having a vessel form consisting of a circular bottom(1201A) from which a grip(1201C) is risen and a perpendicular wall(1201B) which extends upwards from the circumference of said bottom(1201A) and a flange(1202) which is extended from the upper part of said wall(1201B). Said inserting part(1201) has a taper form decreasing in diameter from the base of said inserting part(1201) to the top of said inserting part(1201). Said masking member(1200) is manufactured by vacuum forming of a laminated sheet consisting of a polystyrene foam sheet (1201X) and a thermoplastic film(1201Y). Said masking member(1200) of this embodiment is easily handled by holding said grip(1201C) when the masking member(1200) is inserted into the hole of the article or removed from the hole as same as the twentieth embodiment of the present invention. Further, the surface treatment layer on the article may be cut by the upper edge of said inserting part(1201) as same as the eighteenth embodiment so that said masking member(1200) is easily removed from the hole without the obstruction of said surface treatment layer.

Figure 37 relates to the twenty-second embodiment of the present invention. In this embodiment, a masking member(1210) comprises an inserting part(1211) having a vessel form consisting of a circular bottom(1211A) from which a grip(1211C) is risen, a perpendicular wall(1211B) which extends upwards from the circumference of said bottom (1211A), and a flange(1212) which is extended from the upper edge of said wall(1211B). Said inserting part(1211) has a taper form decreasing in diameter from base of said inserting part(1211) to the top of said inserting part(1211) and the width of said flange(1212) is smaller than the width of the flange(1192) of the masking member(1190) of the twentieth embodiment and said flange(1212) having small width acts as a stopper of the masking

member(1210) when said masking member(1210) is inserted into hole. Said masking member(1210) is manufactured by vacuum forming of a laminated sheet consisting of a polystyrene foam sheet (1211X) and a thermoplastic film(1211Y).

Figure 38 and Figure 39 relate to the twenty-third embodiment of the present invention. In this embodiment, a masking member(1220) consists of an inserting part(1221) having a vessel form consisting of a circular bottom(1221A) and a perpendicular wall(1221B) which extends upwards from the circumference of said bottom(1221A), and a flange (1222) which is extended from the upper edge of said wall (1221B), and has a perpendicular wall(1223) which extends upwards from the circumference of said flange(1222). Said inserting part(1221) has a taper form decreasing in diameter from the base of said inserting part(1221) to the top of said inserting part(1221). Said masking member(1220) is manufactured by vacuum forming of a laminated sheet consisting of a polystyrene foam sheet(1221X) and a thermoplastic film(1221Y).

Said masking member(1220) of this embodiment is used as same as the seventeenth embodiment, and in this embodiment a surface treatment layer such as a coating layer(3220) may be cut by the edge of said perpendicular wall(1221B) as shown in Figure 39, so that said masking member(1220) is easily removed from the hole(2221) of the article(2220) without obstruction of said coating layer (3220).

Figure 40 relates to the twenty-fourth embodiment of the present invention. In this embodiment, a masking member (1230) consists of an inserting part(1231) having a vessel form consisting of a circular bottom(1231A) and a perpendicular wall(1231B) in the middle part of which a horizontal rib(1231C) is formed, and a flange(1232) which is extended from the upper edge of said wall(1231B). Said masking member(1230) is manufactured by vacuum forming of a laminated sheet consisting of a polystyrene foam sheet (1231X) and a thermoplastic film(1231Y).

Said masking member(1230) of this embodiment is used as same as the seventeenth embodiment and said horizontal rib(1231C) reinforces said wall(1231B) of said inserting part(1231) of said masking member(1230) so that said masking member(1230) is firmly inserted into the hole of the article.

Figure 41 relates to the twenty-fifth embodiment of the present invention. In this embodiment, a masking member (1240) consists of an inserting part(1241) having vessel form consisting of a cross-shaped bottom(1241A) and a perpendicular wall(1241B) which extends upwards from the perimeter of said bottom(1241A), a flange(1242) which is extended from the upper edge of said

5 wall(1241B), and a perpendicular wall(1243) which extends upwards from the circumference of said flange(1242). Said masking member (1240) is manufactured by vacuum forming of a laminated sheet consisting of a polystyrene foam sheet(1241X) and a thermoplastic film(1241Y). In this embodiment, said inserting part(1241) is reinforced by said cross-shaped bottom(1241A) to prevent crushing of said inserting part (1241) of said masking member
10 when said masking member (1240) is inserted into the hole of the article, and further said masking member(1240) is supported in the inner wall of said hole by only partially contacts at the tips(1241C) of said inserting part(1241) so that removing of said
15 masking member(1240) from the hole may be very easy.

Figure 42 relates to the twenty-sixth embodiment of the present invention. In this embodiment, a masking member(1250) consists of an inserting part(1251) which has a vessel form and is divided
20 into two crescent parts(1251A) and (1251B) by a grip(1251C) which is risen from the bottom of said inserting part(1251), and a flange(1252) which is extended from the upper edge of said inserting part(1251).
25

Said masking member(1250) of this embodiment is easily manufactured by vacuum forming of a laminated sheet consisting of a polystyrene foam sheet(1251X) and a thermoplastic film(1251Y) and easily removed from the hole since said masking
30 member(1250) partially contacts with the inner wall of the hole, since said inserting part(1251) is divided into two crescent parts(1251A) and (1251B) by said grip(1251C).
35

Figure 43 relates to the twenty-seventh embodiment of the present invention. In this embodiment, a masking member(1260) consists of an inserting part(1261) which has a vessel form and is divided into four parts(1261A), (1261B), (1261C) and (1261D) by a cross-shaped grip(1261E) which
40 is risen from the bottom of said inserting part(1261), and a flange(1262) which is extended from the upper edge of said inserting part(1261). Said masking member(1260) is manufactured by vacuum forming of a laminated sheet consisting of a polystyrene foam sheet(1261X) and a thermoplastic film (1261Y).
45

Said masking member(1260) of this embodiment is used the same as the twenty sixth embodiment and easier removed from the hole since the contacting area of said masking member(1260) with the inner wall of the hole is smaller than the case of the twenty-sixth embodiment so that said
50 inserting part(1261) is divided into four parts(1261A), (1261B), (1261C), and (1261D) by said cross-shaped grip (1261E) and the laminated sheet is saved in this embodiment comprising the masking member having the cylindrical inserting part.
55

Figure 44 relates to the twenty-eighth embodiment of the present invention. In this embodiment, a masking member (1270) consists of an inserting part(1271) having vessel form consisting of a cross-shaped bottom(1271A) and a perpendicular wall(1271B) which extends upwards from the perimeter of said bottom(1271A), a lower flange(1272) which is extended from the upper edge of said wall(1271B), a perpendicular wall(1273) which extends upwards from the circumference of said lower flange(1272), and an upper flange(1274) which is extended from the upper edge of said wall(1273). Said masking member(1270) is manufactured by vacuum forming of a laminated sheet consisting of a polystyrene foam sheet(1271X) and a thermoplastic film(1271Y).

In this embodiment, said inserting part(1271) is reinforced by said cross-shaped bottom(1271A) to prevent crushing of said inserting part(1271) of said masking member when said masking member(1270) is inserted into the hole of the article, and further said masking member(1270) is supported in the inner wall of said hole by only partially contacts at the tips(1271C) of said inserting part(1271) so that removing of said masking member(1270) from the hole may be very easy. The surface treatment layer may be more completely cut by said upper flange(1274) with said lower flange(1272) and said perpendicular wall(1273) than in the case of the twenty-fifth embodiment of the present invention.

Figure 45 and Figure 46 relate to the twenty ninth embodiment of the present invention. In this embodiment, a masking member(1280) consists of an inserting part(1281) having vessel form consisting of a circular bottom(1281A) from which a grip(1281C) is risen and an inner perpendicular wall(1281B) which extends upwards from the circumference of said bottom(1281A), a lower flange(1282) which is extended from the upper part of said wall(1281B), an outer perpendicular wall(1283) which extends upwards from the circumference of said lower flange(1282), and an upper flange(1284) which is extended from the upper part of said wall(1283), and plural radiated ribs(1281D) and (1282A) are respectively formed in said lower flange(1282) and said upper flange(1284). Said inserting part(1281) has a taper form decreasing in diameter from the base to the top of said inserting part (1281). Said masking member(1280) is manufactured by vacuum-forming of a laminated sheet consisting of a polystyrene foam sheet(1281X) and a thermoplastic film(1281Y).

As shown in Figure 46, said masking member(1280) is inserted a hole(2281) of an article(2280) the same as the twentieth embodiment and since a coating layer(3280) may be cut by said upper flange(1284) of said masking member (1280), the removing of said masking member(1280) from said

hole(2281) may be very smooth without obstruction of said coating layer(3280) and further said ribs(1281D) and (1282A) respectively reinforce said lower and upper flanges (1282) and (1284).

Figure 47 and Figure 48 relate to the thirtieth embodiment of the present invention. In this embodiment a masking member(1290) consists of an inserting part(1291) having a vessel form consisting of a circular bottom(1291A) and a perpendicular wall(1291B) which extends upwards from the circumference of said bottom(1291A) and on which plural perpendicular ribs(1291C) are formed, and a flange(1292) which is extended from the upper edge of said wall(1291B). Said inserting part(1291) has a taper form decreasing in diameter from the base to the top of said inserting part (1291). Said masking member is manufactured by vacuum forming of a laminated sheet consisting of a polystyrene foam sheet(1291X) and a thermoplastic film(1291Y). In this embodiment, said perpendicular ribs(1291C) reinforce said perpendicular wall(1291B) to prevent crushing of said inserting part(1291) of said masking member(1290) when said masking member(1290) is inserted into a hole(2291) of an article(2290) as shown in Figure 48 and said masking member(1290) is firmly held in said hole(2291) since said perpendicular ribs(1290C) of said masking member(1290) tightly contact to the inner wall of said hole.

Figure 49 and Figure 50 relate to the thirty-first embodiment of the present invention. In this embodiment, a masking member(1300) consists of an inserting part(1301) having a vessel form consisting of a circular bottom(1301A) from which a grip(1301D) is risen and a perpendicular wall (1301B) which extends upwards from the circumference of said bottom(1301A) and on which plural perpendicular ribs (1301C) are formed, and a flange(1302) which is extended from the upper edge of said wall(1301B). Said inserting part(1301) has a taper form decreasing in diameter from the base to the top of said inserting part(1301). Said masking member(1300) is manufactured by vacuum forming of a laminated sheet consisting of a polystyrene foam sheet(1301X) and a thermoplastic film(1301Y). In this embodiment, said perpendicular ribs(1301C) reinforce said perpendicular wall (1301B) to prevent crushing of said inserting part(1301) of said masking member(1300) when said masking member (1300) is inserted into a hole(2301) of an article(2300) as shown in Figure 50 and said masking member(1300) is firmly held in said hole(2301) since said perpendicular ribs(1301C) of said masking member(1300) tightly contact to the inner wall of said hole(2301). Further, said masking member(1300) of this embodiment is easily handled by holding said grip (1301D) when said masking member(1300) is inserted into said

hole(2301).

Figure 51 relates to the thirty-second embodiment of the present invention. In this embodiment, a masking member (1310) consists of an inserting part(1311) having a vessel form consisting of a circular bottom(1311A) from which a grip(1311D) is risen and a perpendicular wall(1311B) which extends upwards from the circumference of said bottom(1311A) and on which plural perpendicular ribs(1311C) are formed, a lower flange(1312) which is extended from the upper edge of said wall(1311B), a perpendicular wall(1313) which extends upwards from the circumference of said flange(1312), and an upper flange(1314) which is extended from the upper edge of said perpendicular wall(1313). Said inserting part(1311) has a taper form decreasing in diameter from the base of said inserting part(1311) to the top of said inserting part(1311). Said masking member is manufactured by vacuum forming of a laminated sheet consisting of a polystyrene foam sheet(1311X) and a thermoplastic film(1311Y).

In this embodiment, said perpendicular ribs(1311C) reinforce said perpendicular wall(1311B) to prevent crushing of said inserting part(1311) of said masking member(1310) when said masking member(1310) is inserted into a hole(2311) of an article(2310) and said masking member (1310) is firmly held in the hole since said perpendicular ribs(1311C) of said masking member(1310) tightly contact to the inner wall of said hole. Further, said masking member (1310) of this embodiment is easily handled by holding said grip(1311D) when said masking member(1310) is inserted into the hole as same as the thirty-second embodiment and the surface treatment layer may be more completely cut by said upper flange(1314) with said lower flange(1312) and said perpendicular wall(1313) than in the case of the thirtieth and thirty-first embodiments of the present invention so that said masking member(1310) is more easily removed from the hole without the obstruction of the surface treatment layer.

[Masking member D]

Masking member D is used to protect the panel-like part of the article.

Figure 52 to Figure 54 relate to the thirty-third embodiment of the present invention. In this embodiment, a masking member(1320) consists of a body(1321) having a cylindrical vessel form, which has a slit(1322) formed from the opening end of said body(1321). Said masking member is manufactured by vacuum forming of a laminated sheet consisting of a polystyrene foam sheet(1321X) and a thermoplastic film(1321Y). A panel-like part(2321)

of an article(2320) to be protected is inserted into said slit (1322) of said masking member(1320) and a surface treatment layer such as a coating layer(3320) is not formed on said panel-like part(2321) since said panel-like part(2321) is protected by said masking member(1320) as shown in Figure 53. After surface treatment, said masking member is removed by heating as shown in Figure 54 or by hook without or before heating.

Figure 55 relates to the thirty-fourth embodiment of the present invention. In this embodiment, a masking member (1330) consists of a body(1331) having a square vessel form and a slit(1332) which is formed from the opening end of said body(1331). Said masking member is manufactured by vacuum forming of a laminated sheet consisting of a polystyrene foam sheet(1331X) and a thermoplastic film(1331Y). Said masking member is used the same as the thirty-third embodiment.

[Application of the present invention to the under side of the car body]

Figure 56 to Figure 61 relate to an applied embodiment in which the present invention is applied to the coating of viscoelastic material on the under side of the car body.

As shown in Fig. 56, the masking members of the present invention are attached to parts A, B, C, D and E of the under side(2341) of a car body(2340). Namely, as shown in Figure 57, the masking member C, such as said masking member (1160) of Figure 29 of the seventeenth embodiment may be attached to a hole(2341A) of part A into which a spring axis of a forward wheel is inserted and the circumference of the hole(2341A) is used as a bed for the spring. Therefore, the inside of the hole(2341A) is covered with the inserting part(1161) of the masking member(1160) and the circumference of the hole(2341) is covered with the flange(1162) of the masking member(1160) to protect these from the coating of viscoelastic material.

As shown in Figure 58, the masking member B, such as said masking member(1110) of the twelfth embodiment is attached to a bolt(2341B) of part B which is used to attach a part to the underside(2341) of the car body(2340).

As shown in Figure 59, the masking member(1190) of the twentieth embodiment is inserted into a drainage hole(2341C), as shown in Figure 60, the masking member D, such as the masking member(1320) of the thirty-third embodiment is attached to a bracket(2341D) of part D which is used to attach a part to the under side(2341) of the car body(2340), and as shown in Figure 61, the masking member(100) of the first embodiment is attached to a screw hole(2341E) which is used to attach a part

to the under side(2341) of the car body(2340). Thus, said hole(2341A), said bolt(2341B), said drainage hole(2341C), said bracket(2341D) and said screw hole(2341E) are protected by said masking members of the present invention from the coating of viscoelastic material.

[Masking member E]

Masking member E is used to protect the hollow part of an article.

Figures 62 to 66 relate to the thirty-fifth embodiment of the present invention. In this embodiment, a masking member(1340) comprises a body-(1341) manufactured by the vacuum forming of a laminated sheet consisting of a polystyrene foam sheet(1341X) and a thermoplastic film(1341Y), and an adhesive layer(1342) formed on the circumference of the outer side of said body(1341). Said masking member(1340) is used to protect an air-inlet(2351) of a bumper(2350) of a car as shown in Figure 64. In Figure 64, a pair of supporting pillars-(2351A), a plural number of vertical pieces(2351B), and a plural number of cross pieces(2551C) are formed inside said air-inlet(2351) and therefore a pair of inlaying parts(1341A) of said supporting pillars(2351A), a plural number of inlaying parts-(1341B) of said vertical pieces(2351B), and a plural number of inlaying parts (1341C) of said cross pieces(2551C) are formed on said body (1341) of said masking member(1340). Further, said adhesive layer(1342) may be covered with a release sheet.

When said masking member(1340) is used, if said adhesive layer(1342) is covered with said release sheet, said release sheet is removed from said adhesive layer(1342) of said masking member(1340) and said masking member(1340) is inlaid into said air-inlet(2351) of said bumper(2350). In this state, said supporting pillars(2351A) are inlaid in said inlaying parts(1341A) of said body-(1341) of said masking member(1340), said vertical pieces(2351B) are inlaid in said inlaying parts-(1341B) of said body(1341) of said masking member(1340), and said cross pieces(2551C) are inlaid in said inlaying parts(1341C) of said body-(1341) of said masking member(1340), and the circumference of the outer side of said body(1341) of said masking member(1340) is tightly attached to the inside of said air-inlet(2351) by said adhesive layer(1342). After said masking member (1340) is attached to the inside of said air-inlet(2351), a paint is coated on said bumper(2350) by a spray gun (4340) to form a coating layer(3340) and said coating layer (3340) is not formed inside said air-inlet-(2351) since the inside of said air inlet(2351) is

protected by said masking member(1340). After coating, said masking member(1340) is removed from the inside of said air-inlet(2351) by a hook (5340) or worker's hand as shown in Figure 66.

[Masking member F]

Masking member F is used to protect a plural number of protruding parts of an article.

Figure 67 and Figure 68 relate to the thirty-sixth embodiment of the present invention. A masking member (1350) is manufactured by the vacuum forming of a laminated sheet(1351) consisting of a polystyrene foam sheet(1351X) and a thermoplastic film(1351Y) and a pair of insertion parts(1351A) are formed in said laminated sheet(1351) of said masking member(1350).

Said masking member(1350) is attached a part-(2361) having a pair of protruding parts(2361A) by inserting said protruding parts(2361) into said insertion parts(1351A) of said masking member(1350) to protect said part(2361) together with said protruding parts(2361A).

Claims

1. A masking member consisting of a laminated sheet which comprises a polystyrene foam sheet and thermoplastic film(s) laminated one or both side(s) of said polystyrene foam sheet.

2. The masking member in accordance with Claim 1 which comprises a body having vessel form consisting of a bottom and perpendicular wall(s) which extend(s) upwards from the perimeter of said bottom, and an adhesive layer formed on the under surface of said body.

3. The masking member in accordance with Claim 1 or 2 which comprises a body having vessel form consisting of a bottom, perpendicular wall(s) which extend(s) upwards from the perimeter of said bottom and a flange which is extended from the upper edge(s) of said wall(s), and an adhesive layer formed on the surface of said flange.

4. The masking member in accordance with any of Claims 1 to 3 which comprises an inserting part having a vessel form consisting of a bottom and perpendicular wall(s) which extend(s) upwards from the perimeter of said bottom.

5. The masking member in accordance with any of Claims 1 to 4 consisting of a body having a vessel form which has a slit formed from the opening end of said body.

6. The masking member in accordance with any of Claims 1 to 5 having a shape fitting a hollow part of an article to be protected by said masking member from a surface treatment.

7. The masking member in accordance with any of Claims 1 to 6, having a plural number of inserting part having shapes fitting a plural number of protruding parts of an article to be protected by said masking member from a surface treatment. 5

8. The masking member in accordance with any of Claims 1 to 7, manufactured by vacuum forming of said laminated sheet.

9. The masking member in accordance with any of Claims 1 to 8, said thermoplastic film is a high impact polystyrene film. 10

10. The masking member in accordance with any of Claims 1 to 8, said thermoplastic film is a polyethylene film.

11. The masking member in accordance with any of Claims 1 to 8, said thermoplastic film is a polypropylene film. 15

20

25

30

35

40

45

50

55

15

FIG. 1

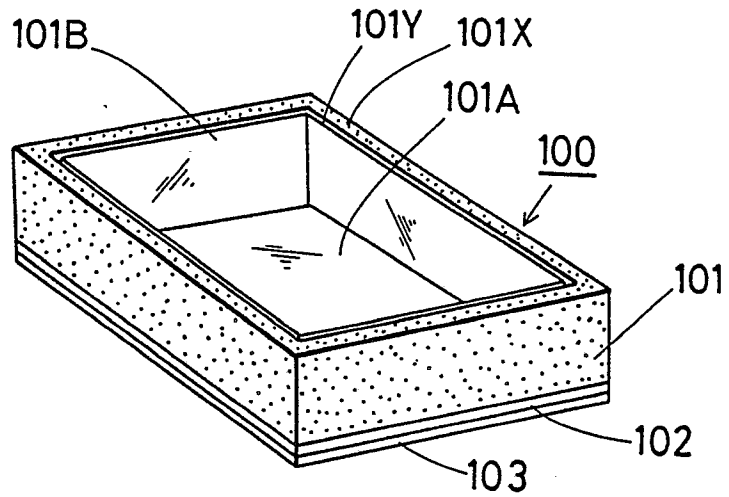

FIG. 2

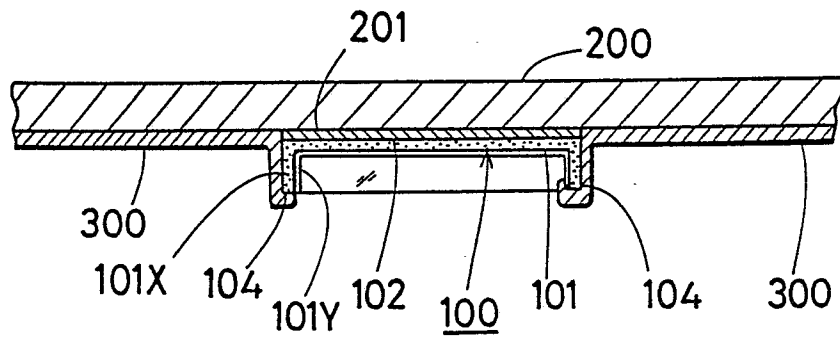

FIG. 3

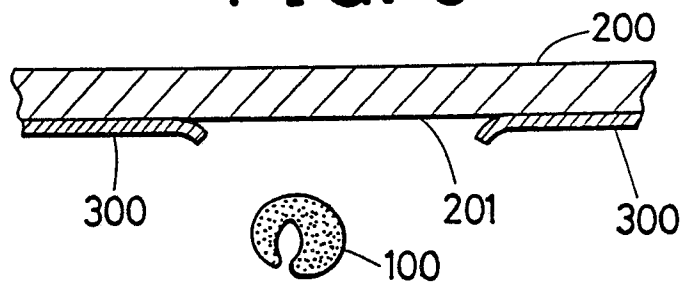

FIG. 4

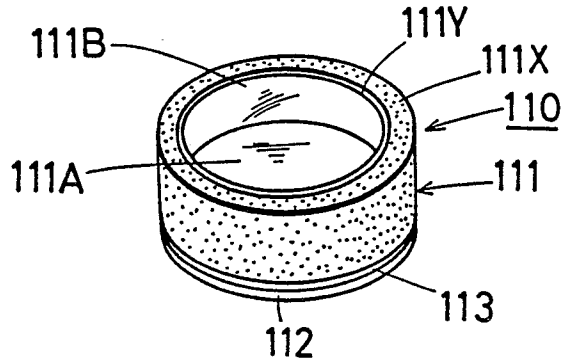

FIG. 5

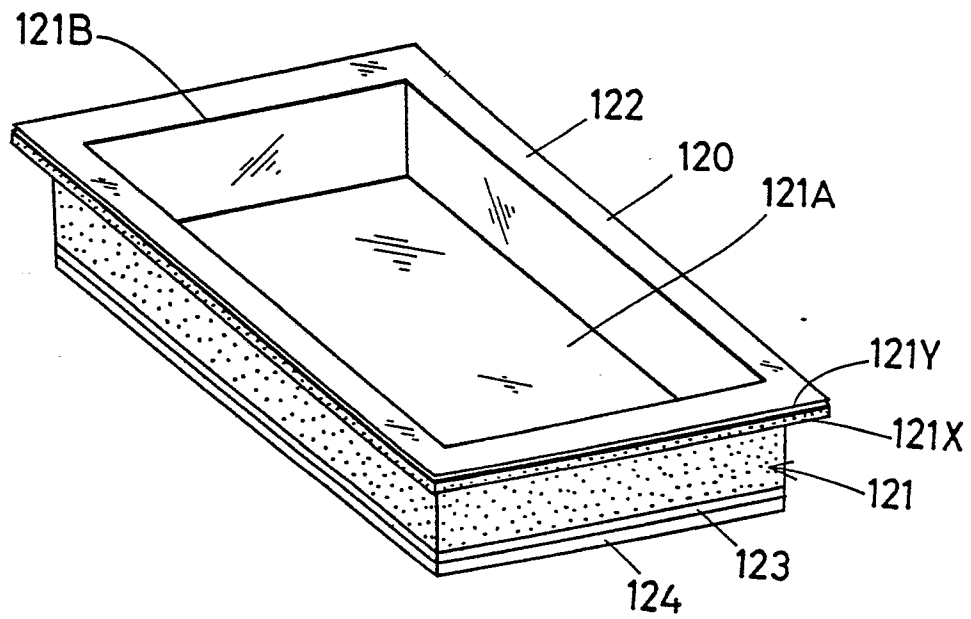

FIG. 6

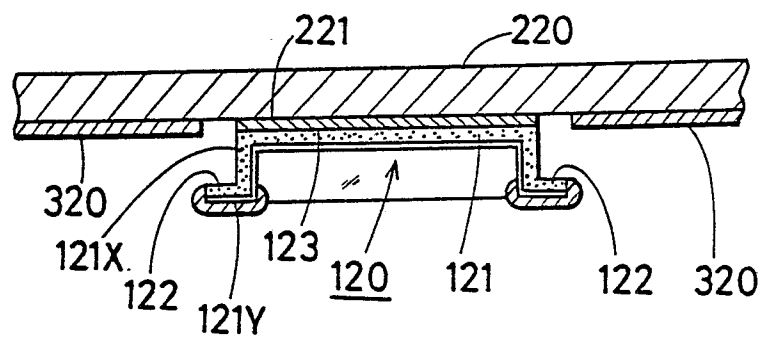

FIG. 7

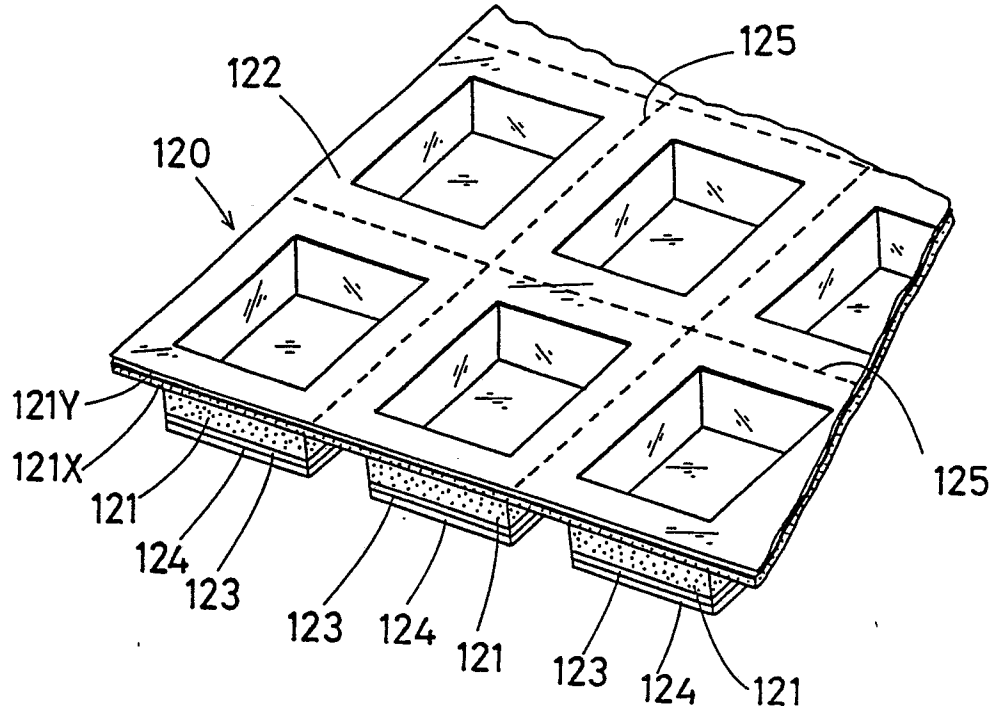

FIG. 8

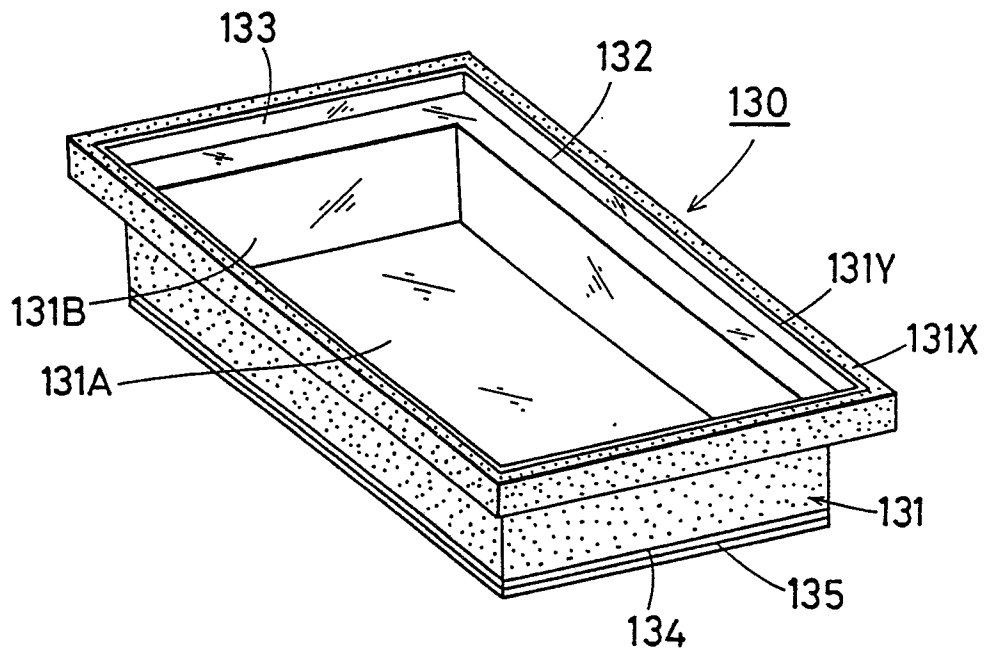

FIG. 9

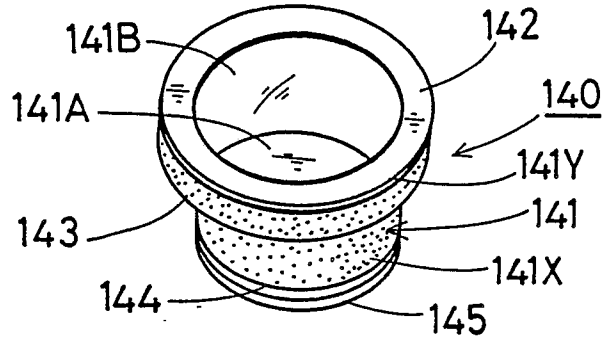

FIG. 10

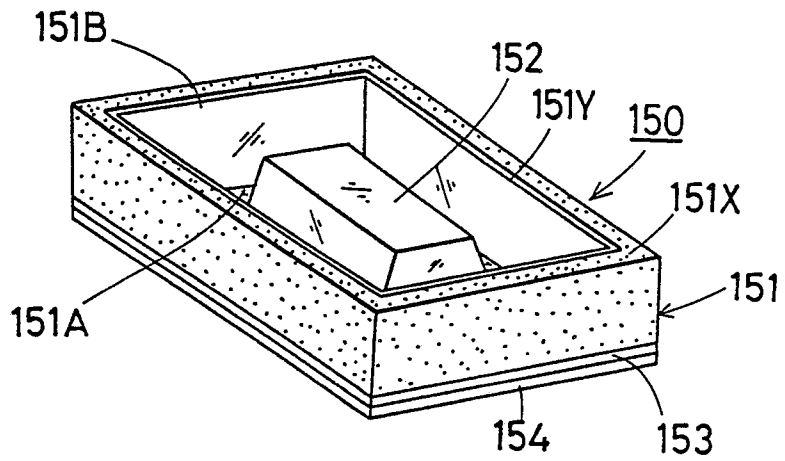

FIG. 11

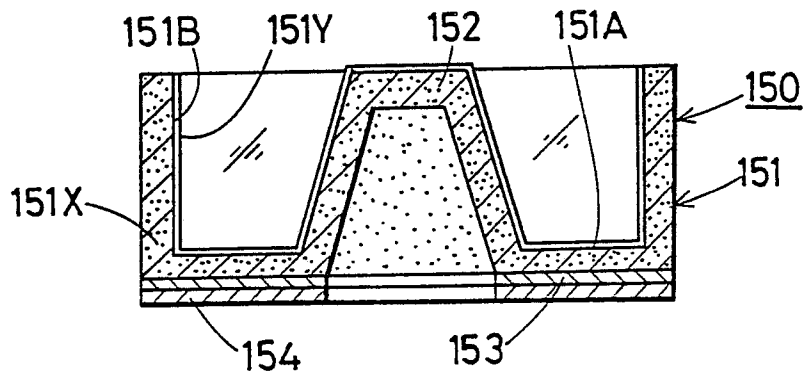

FIG. 12

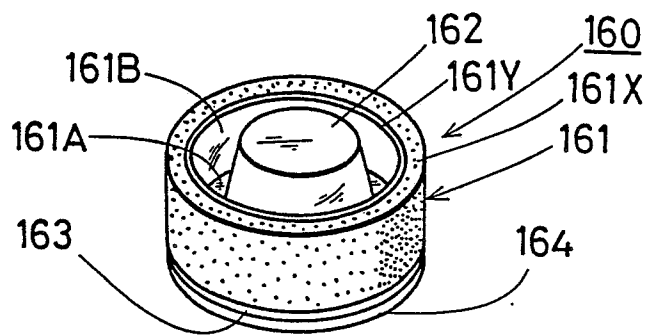

FIG. 13

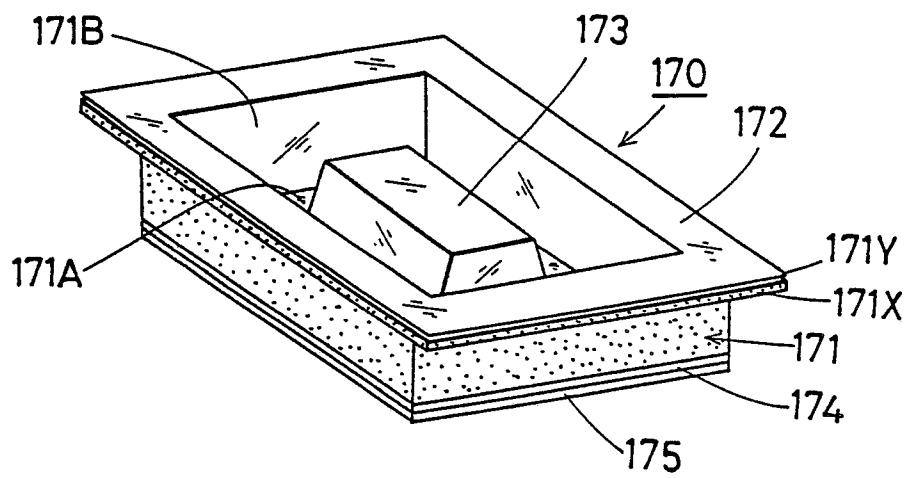

FIG. 14

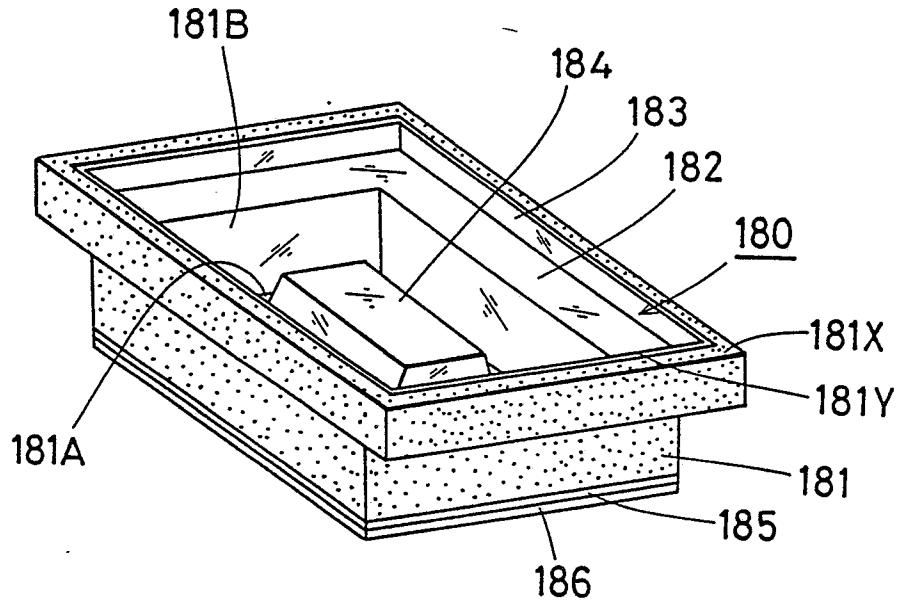

FIG. 15

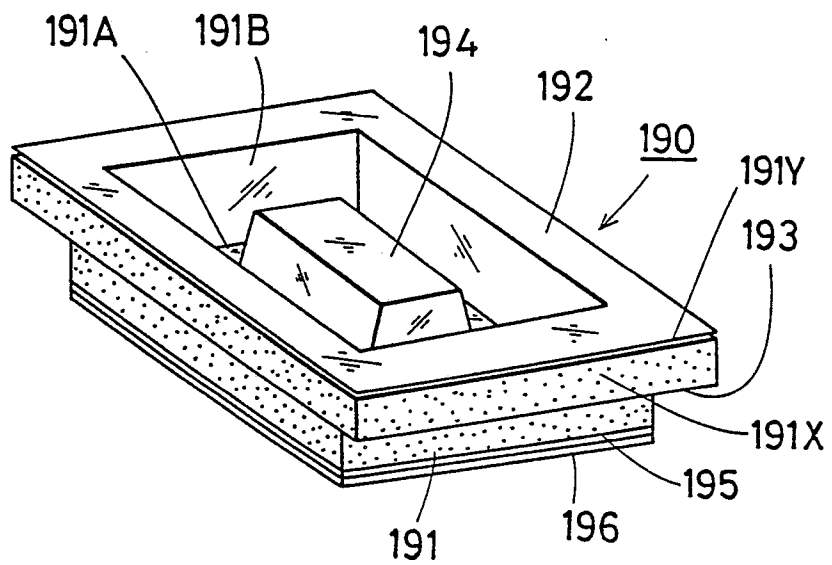

FIG. 16

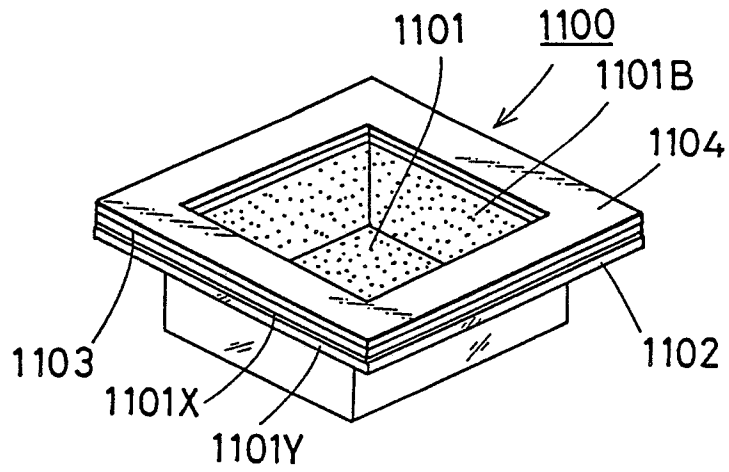

FIG. 17

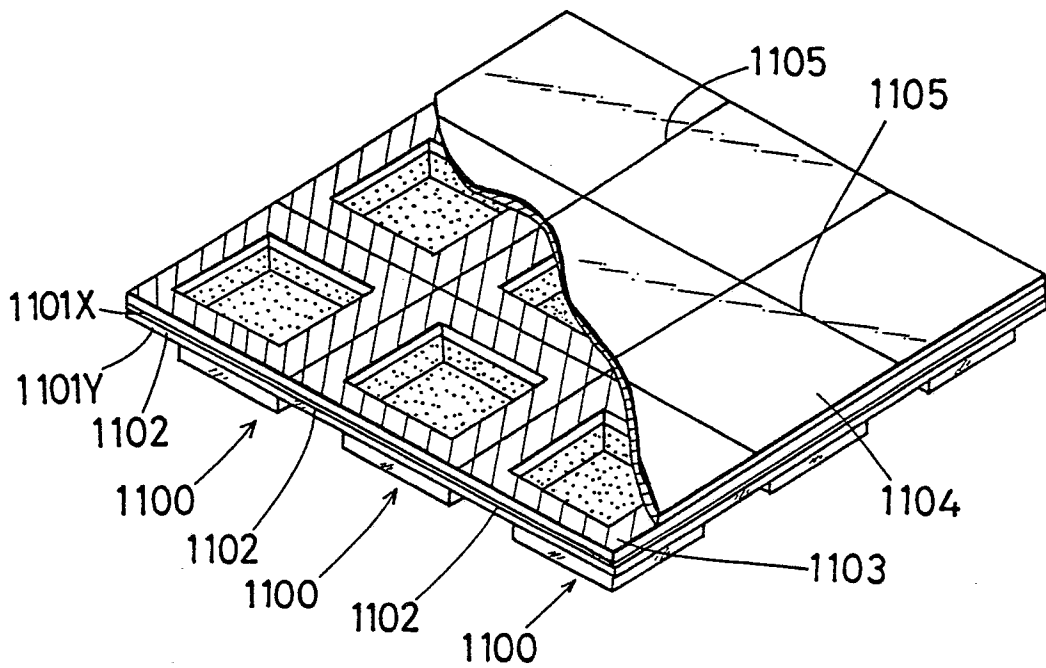

FIG. 18

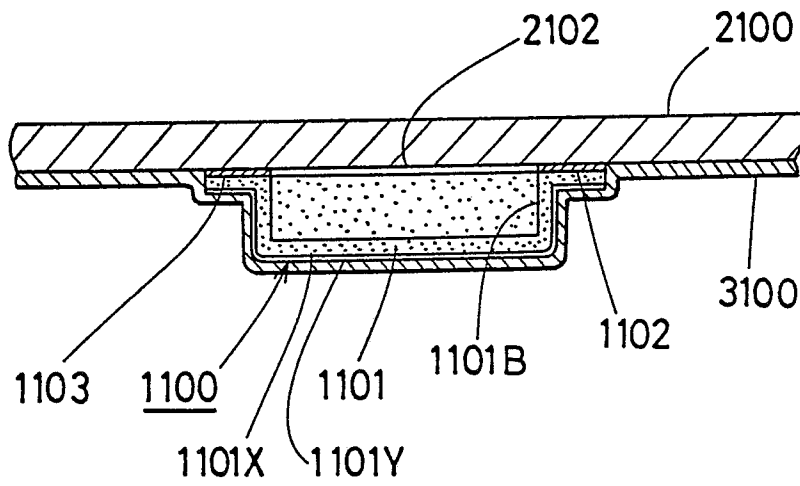

FIG. 19

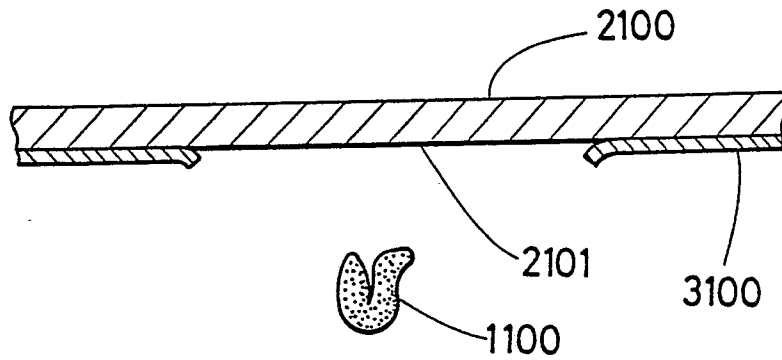

FIG. 20

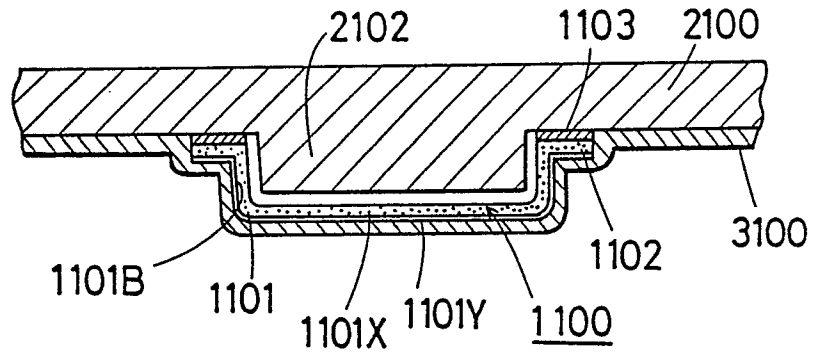

FIG. 21

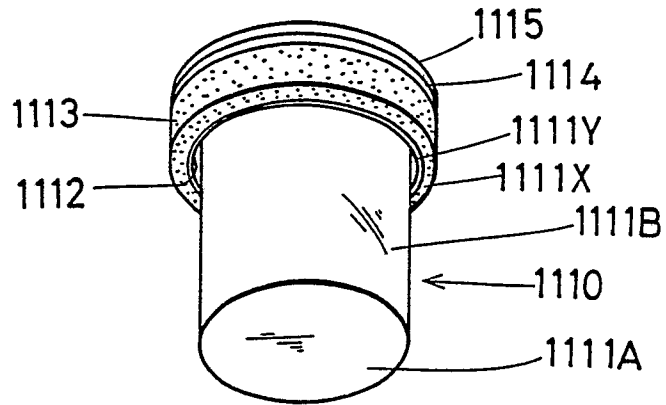

FIG. 22

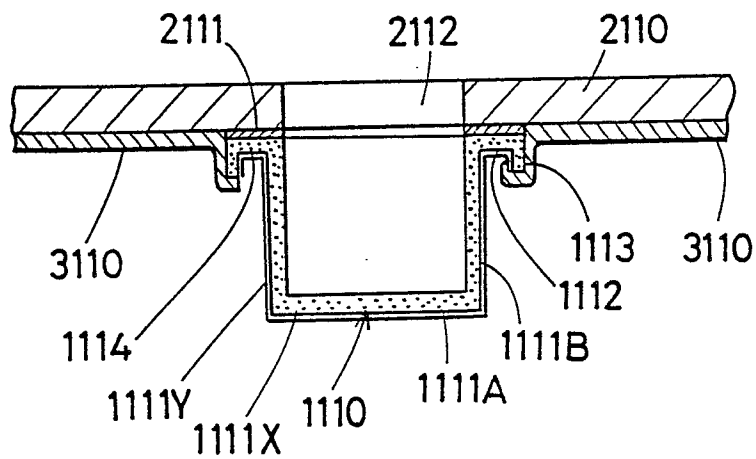

FIG. 23

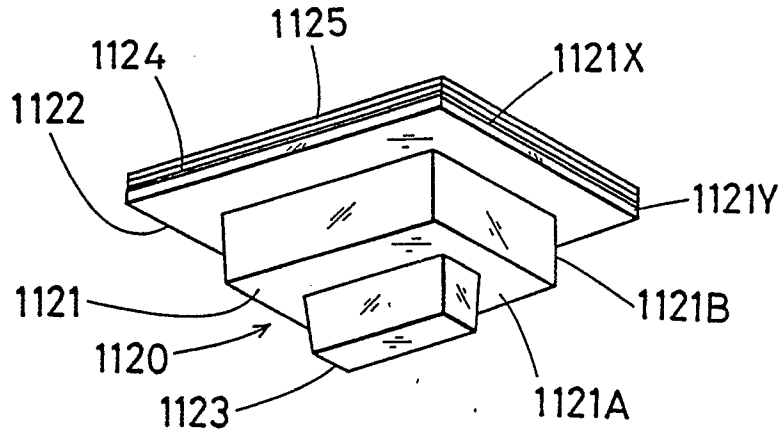

FIG. 24

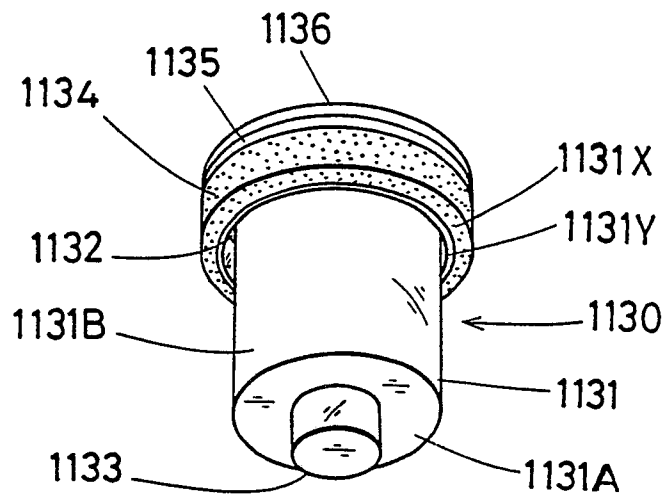

FIG. 25

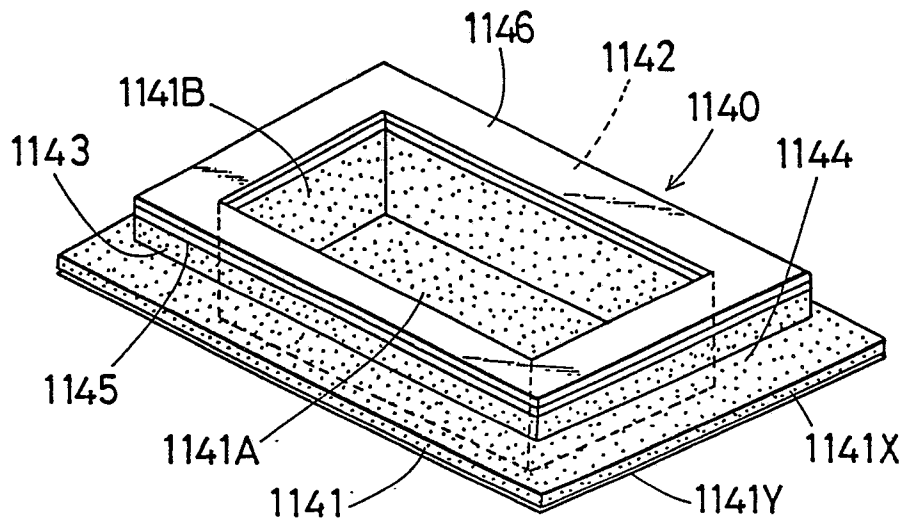

FIG. 26

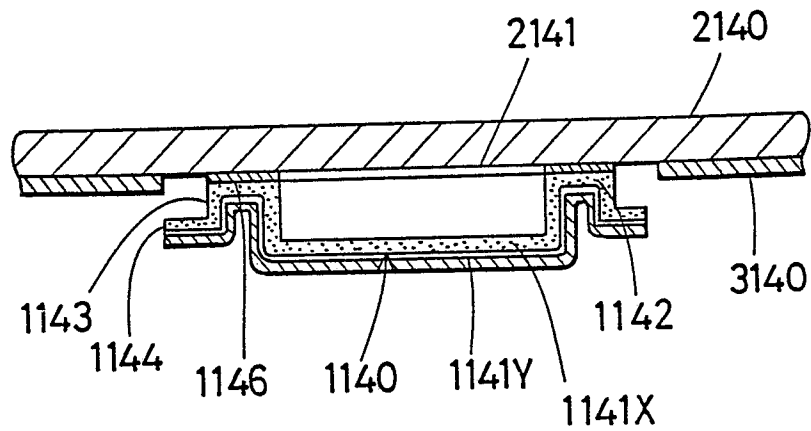

FIG. 27

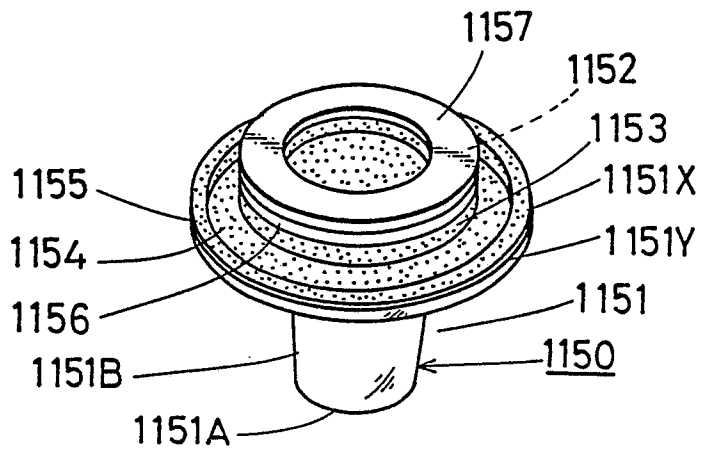

FIG. 28

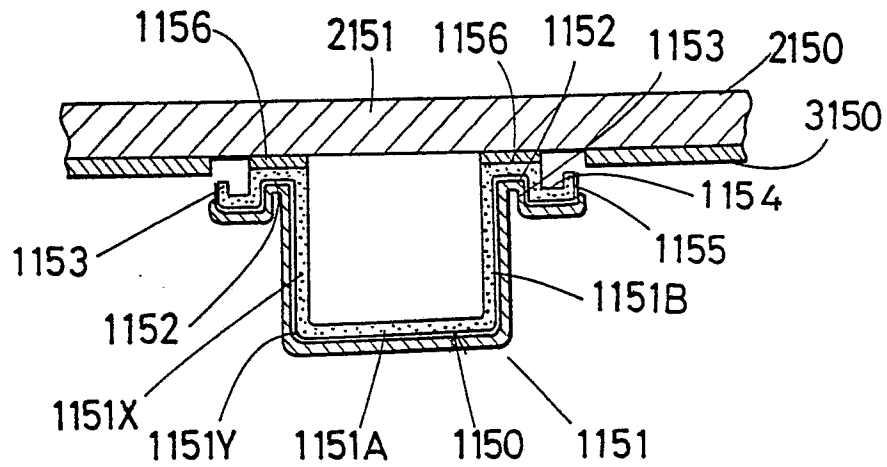

FIG. 29

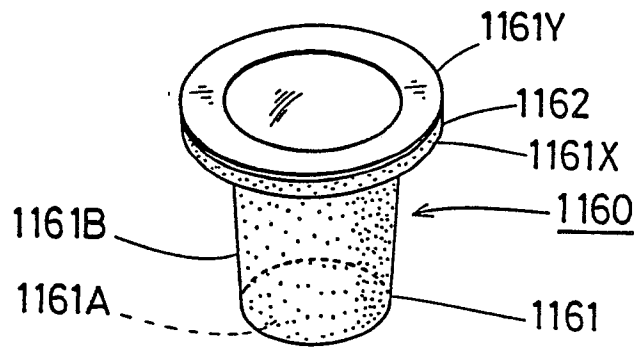

FIG. 30

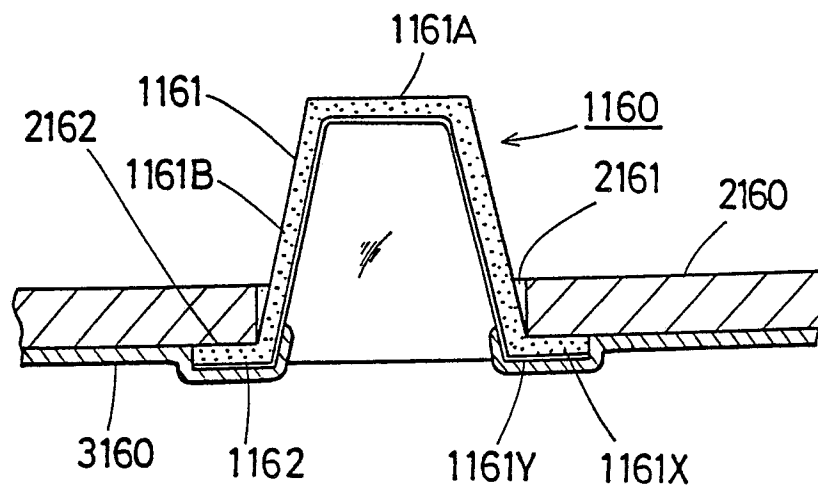

FIG. 31

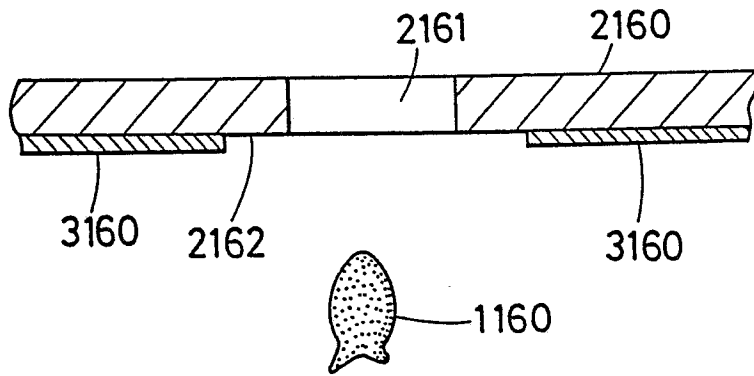

FIG. 32

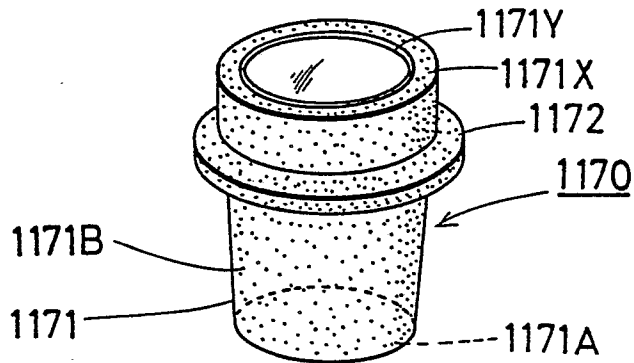

FIG. 33

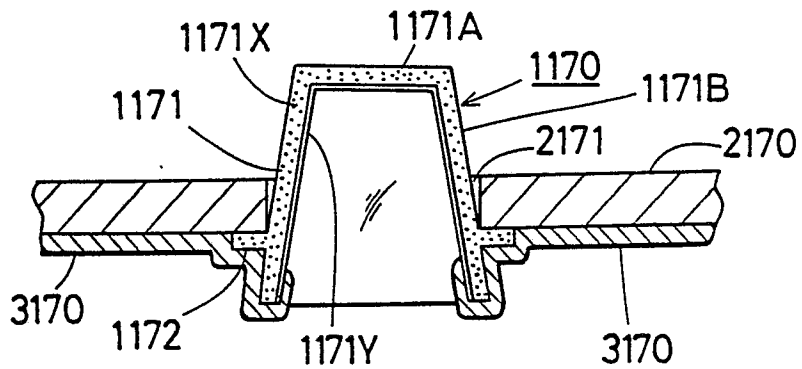

FIG. 34

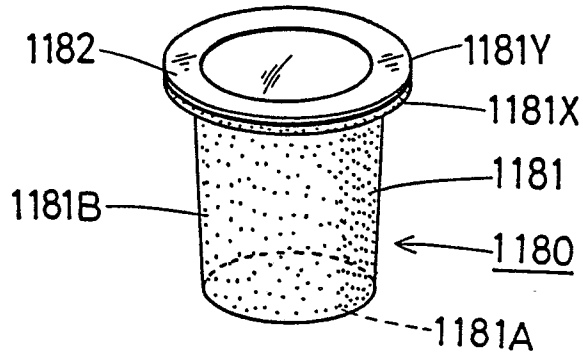

FIG. 35

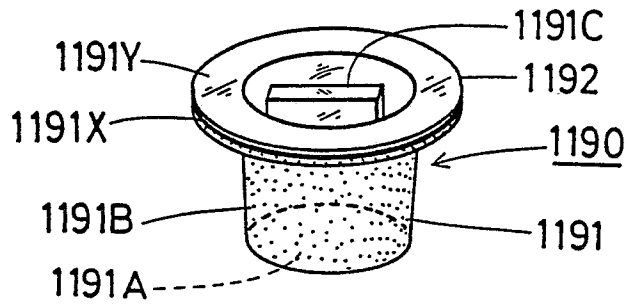

FIG. 36

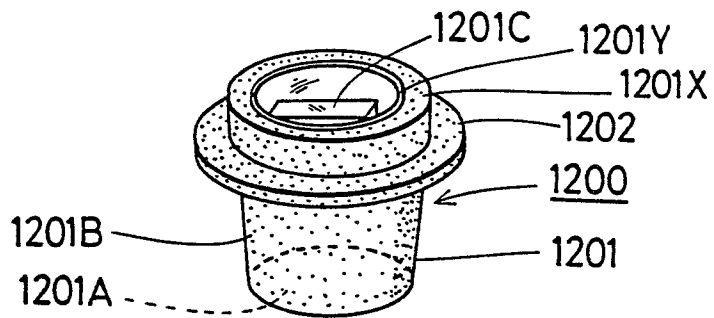

FIG. 37

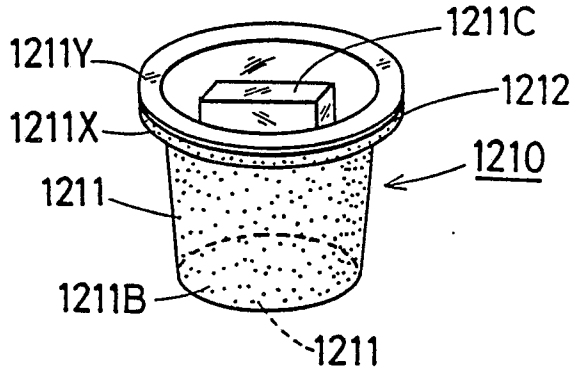

FIG. 38

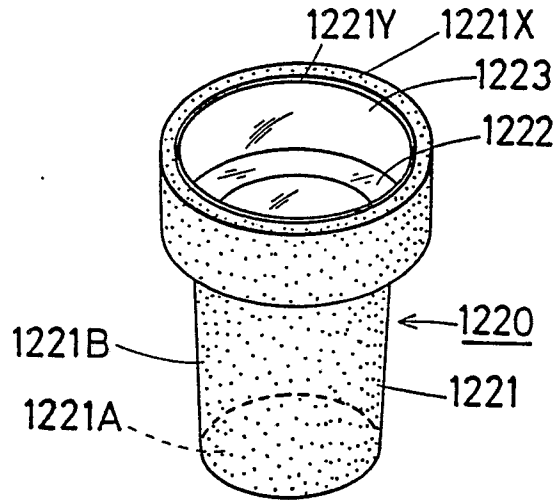

FIG. 39

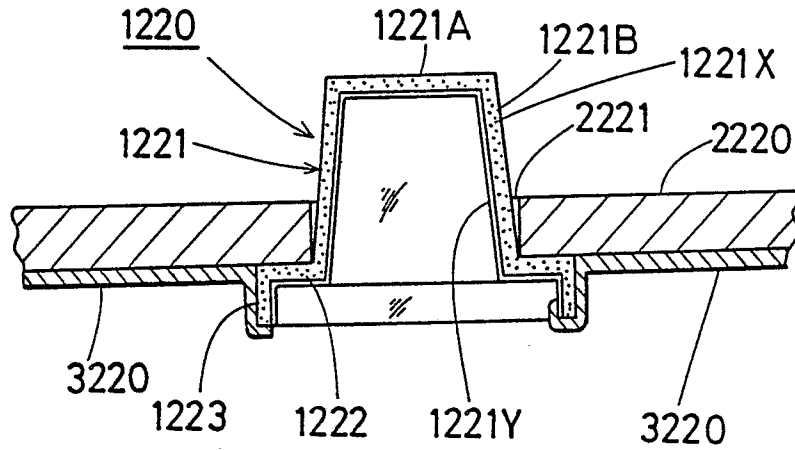

FIG. 40

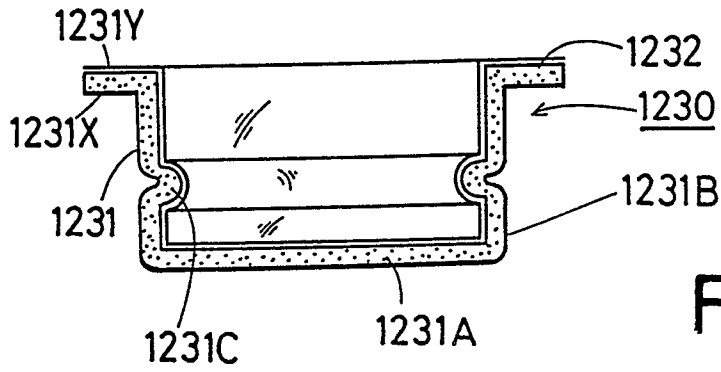

FIG. 41

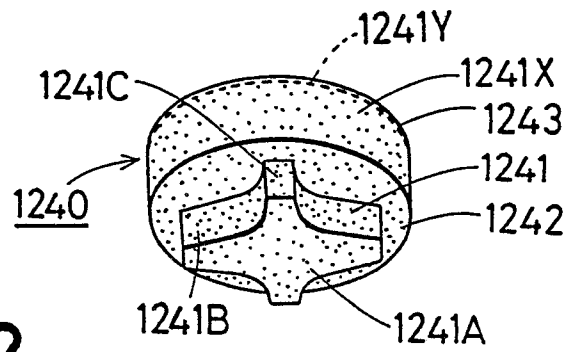

FIG. 42

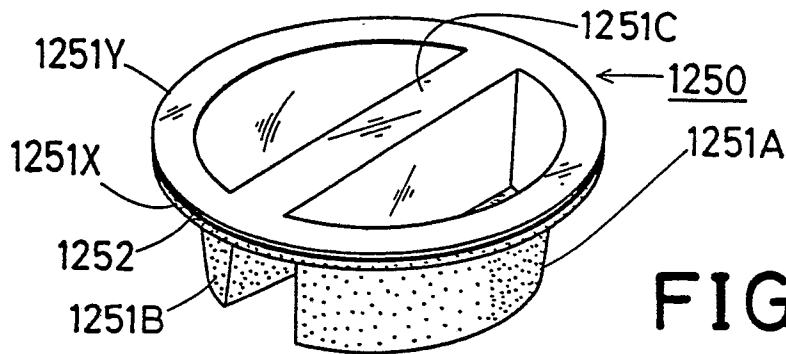

FIG. 43

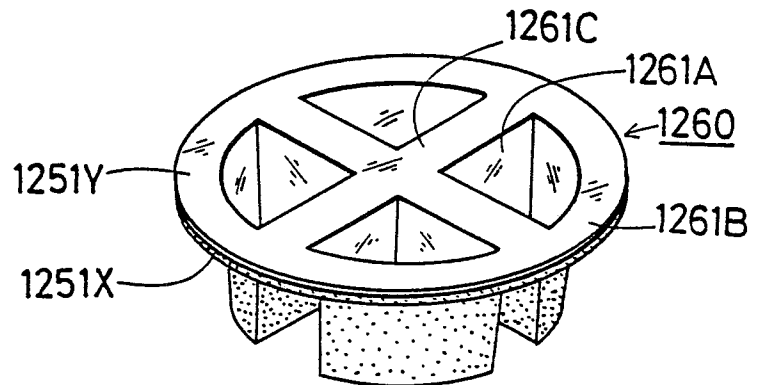

FIG. 44

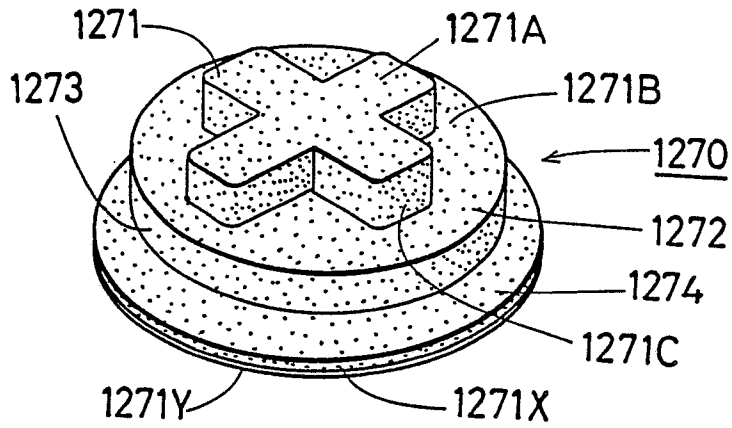

FIG. 45

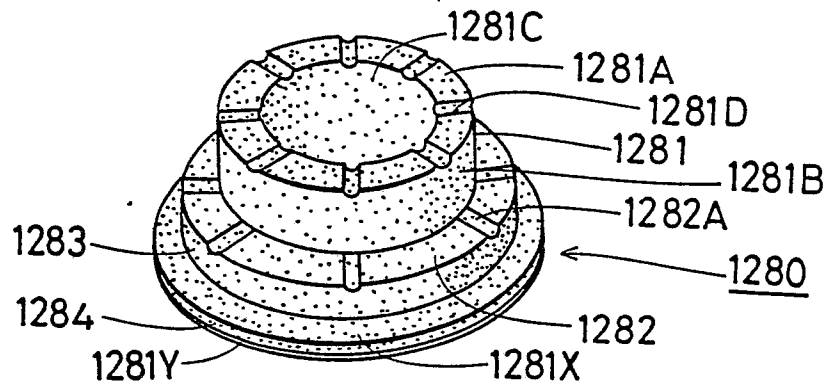

FIG. 46

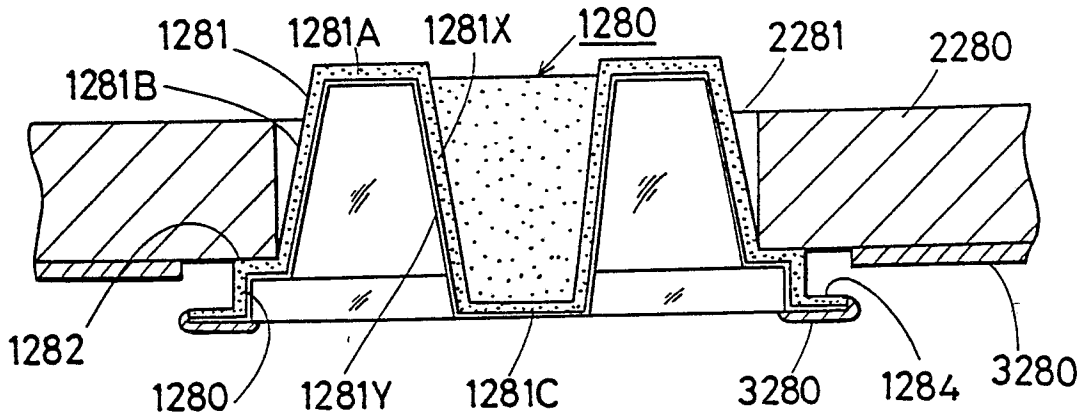

FIG. 47

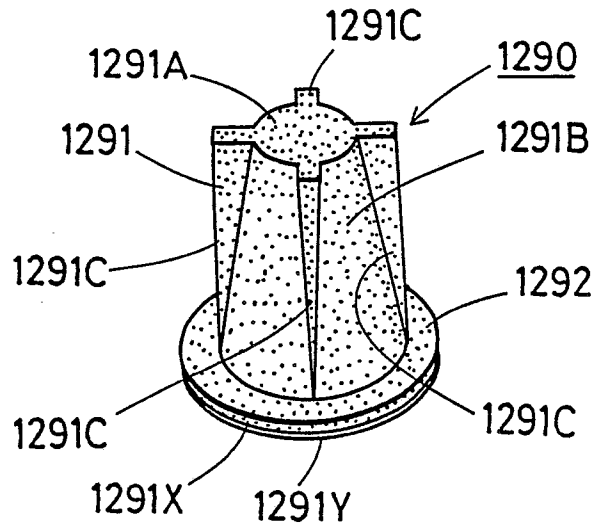

FIG. 48

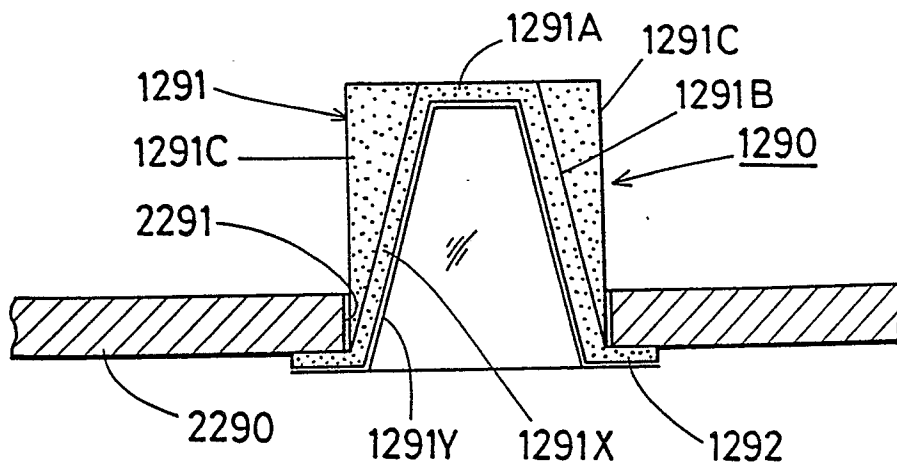

FIG. 49

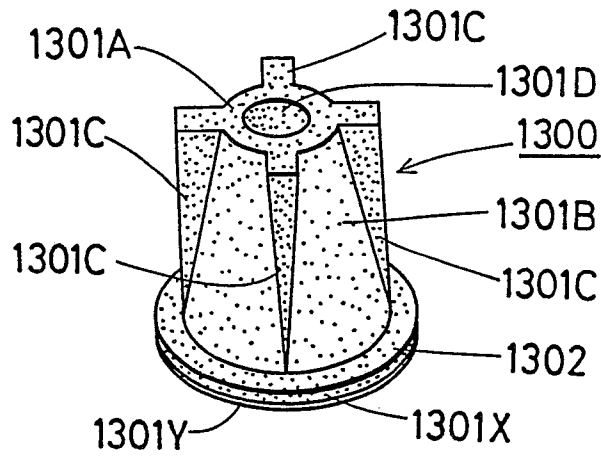

FIG. 50

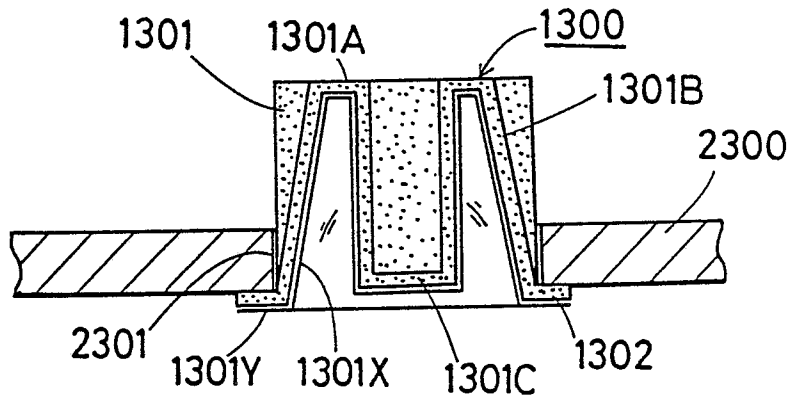

FIG. 51

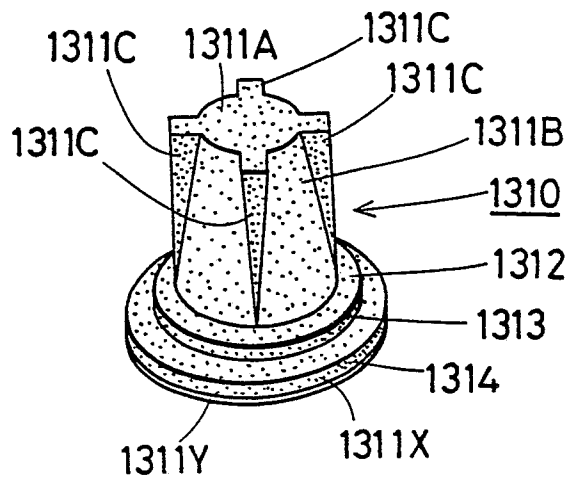

FIG. 52

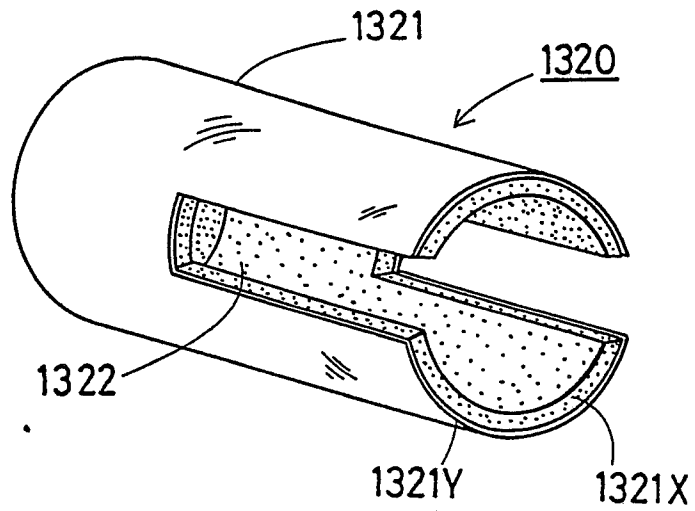

FIG. 53

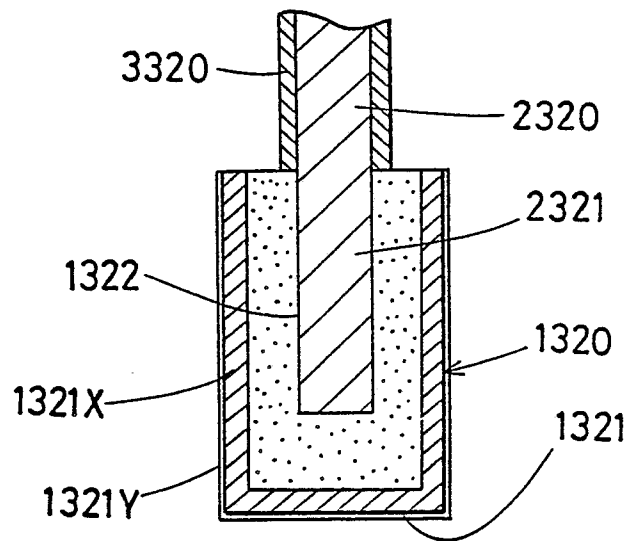

FIG. 54

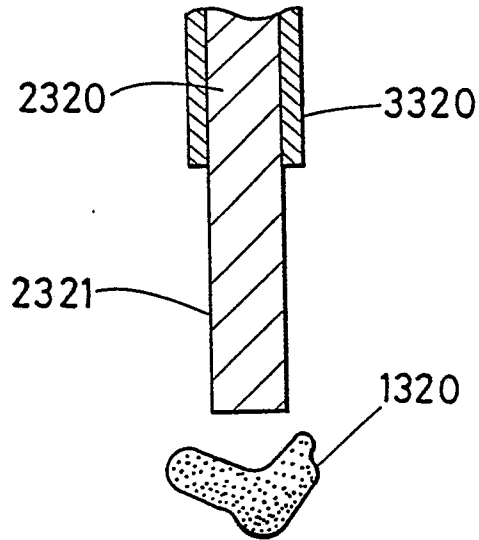

FIG. 55

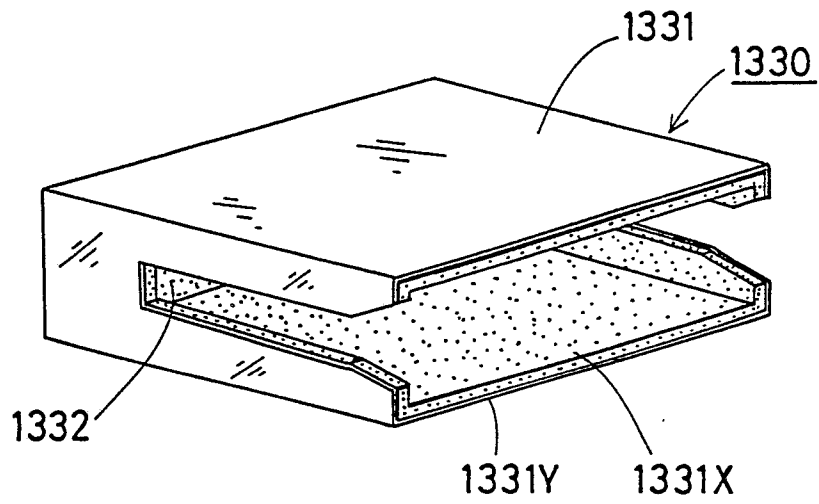

FIG. 56

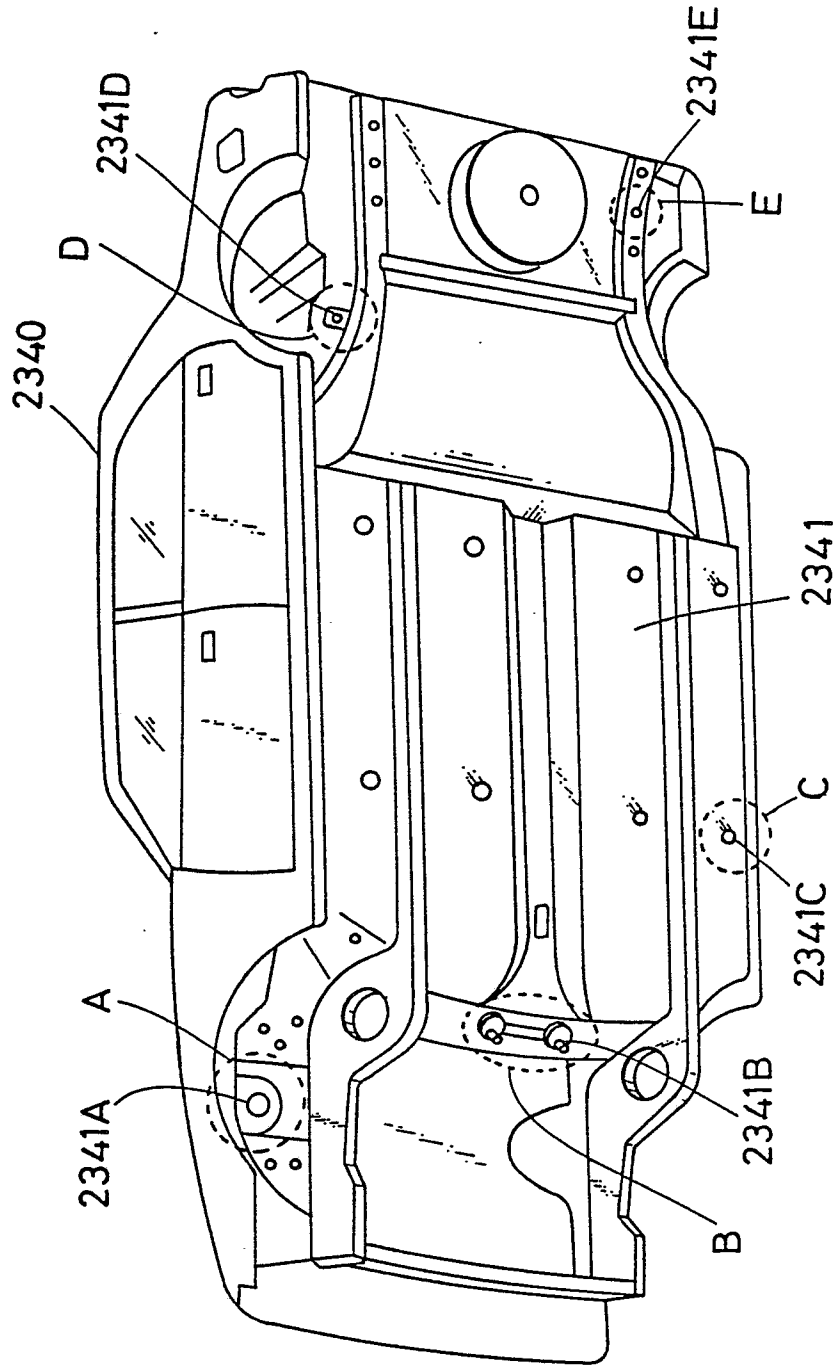

FIG. 57

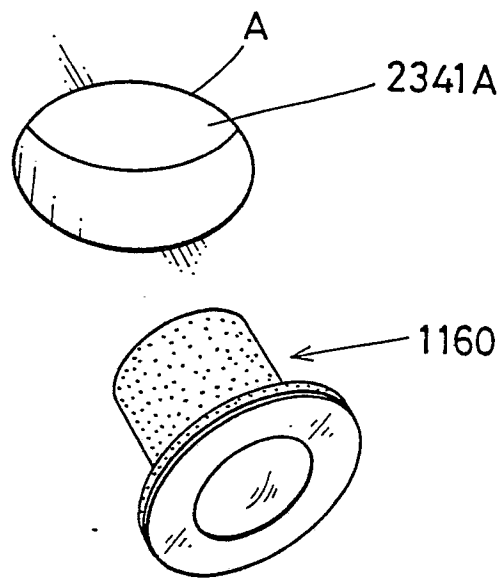

FIG. 58

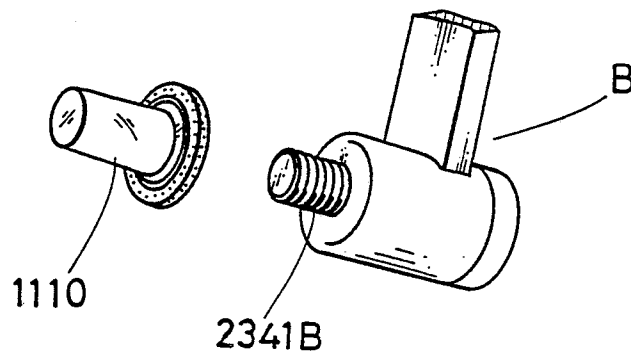

FIG.59

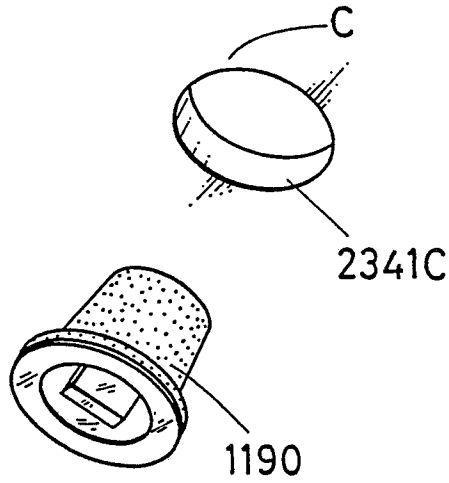

FIG.60

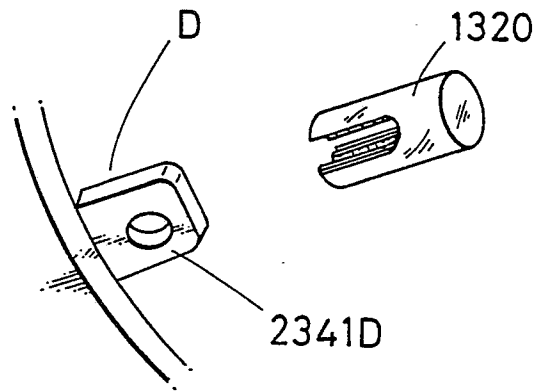

FIG.61

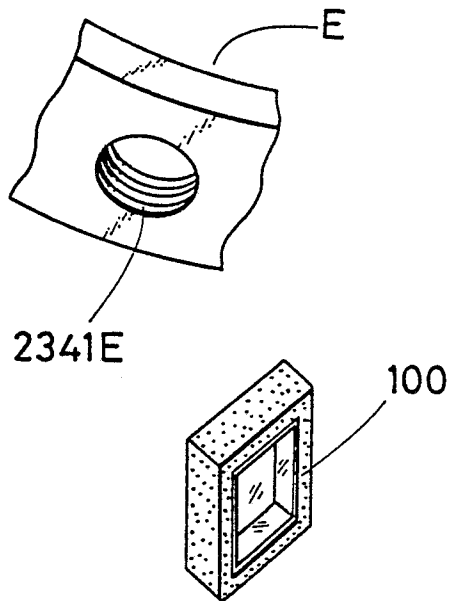

FIG. 62

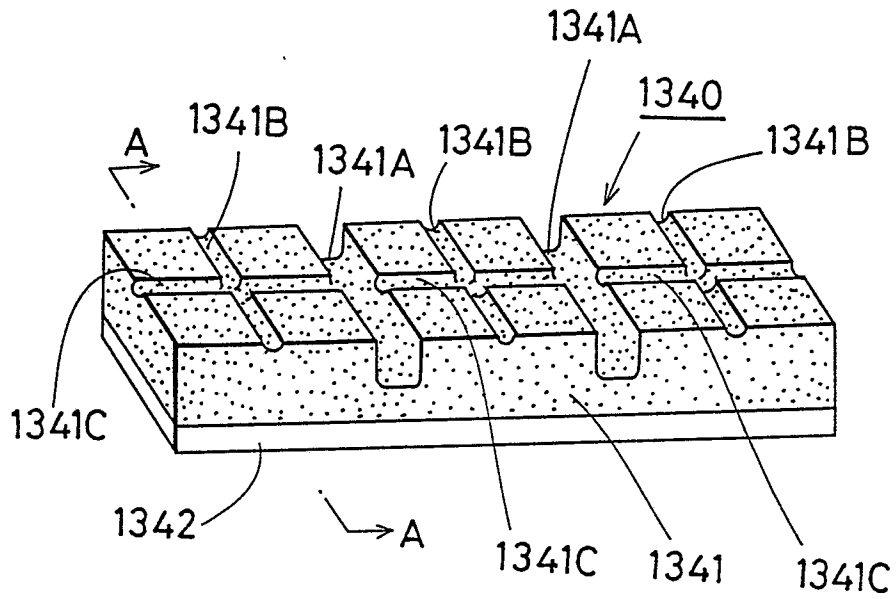

FIG. 63

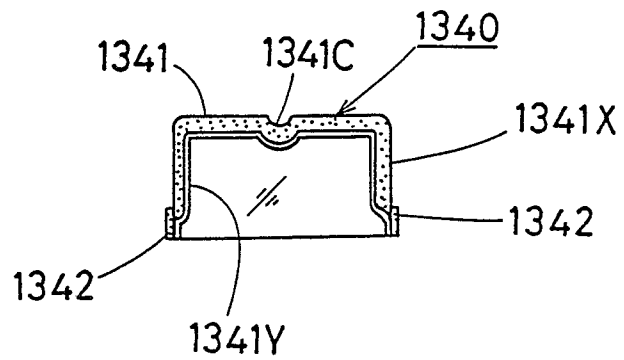

FIG. 64

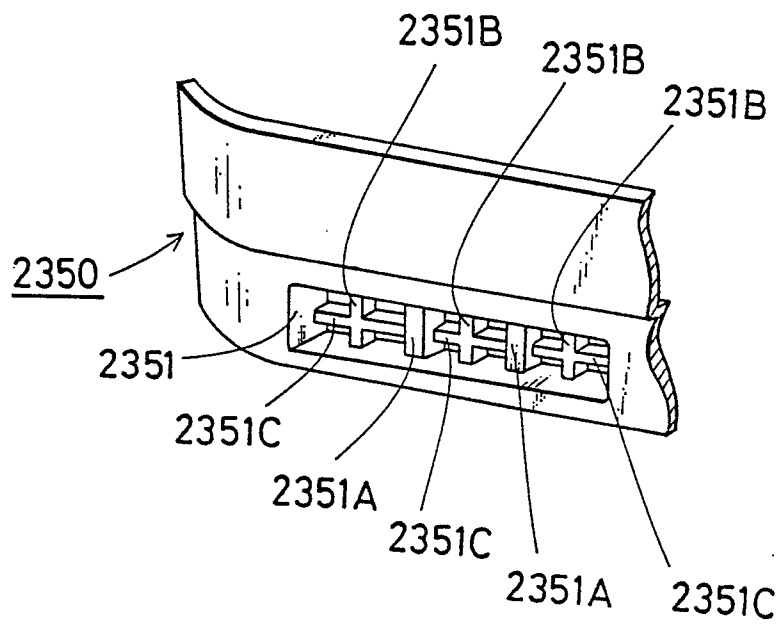

FIG. 65

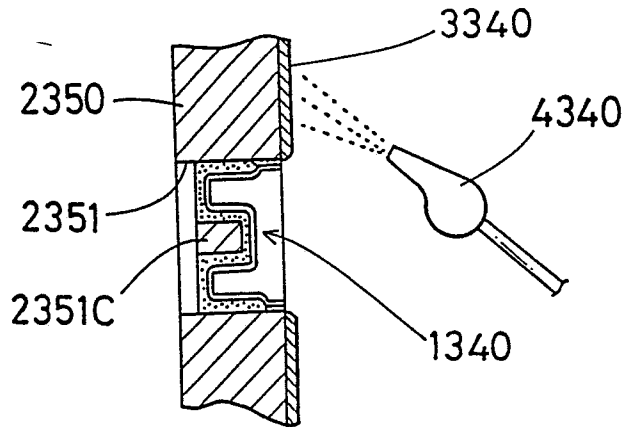

FIG. 66

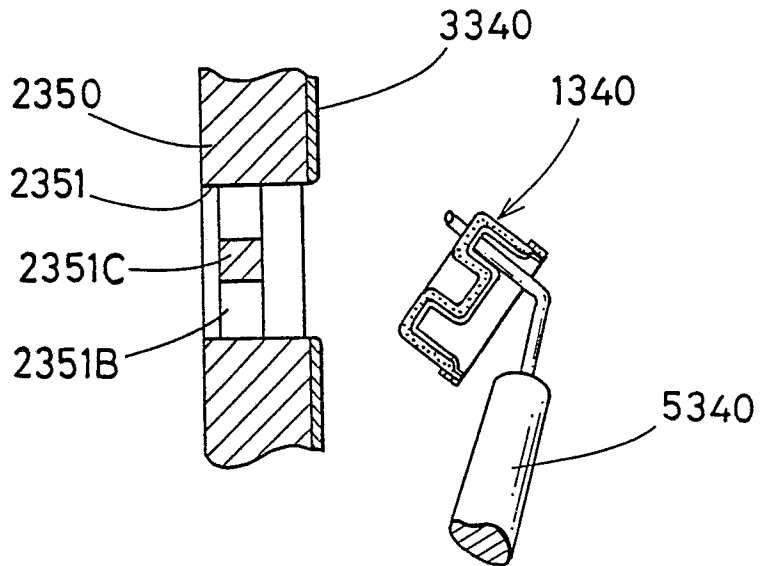

FIG. 67

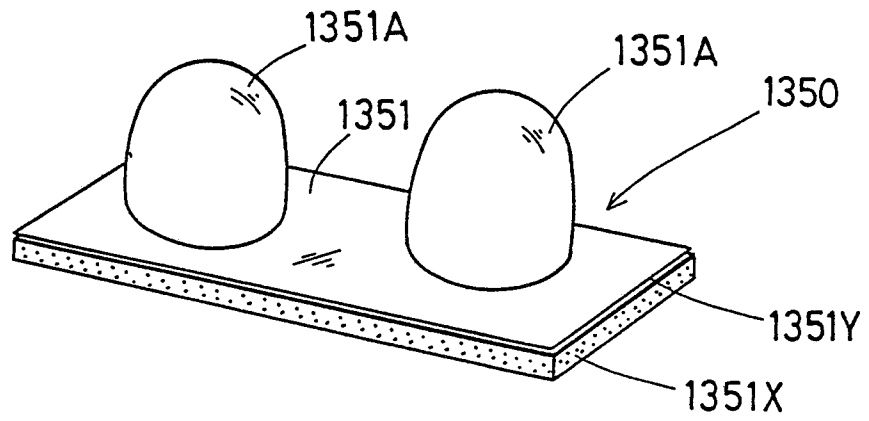
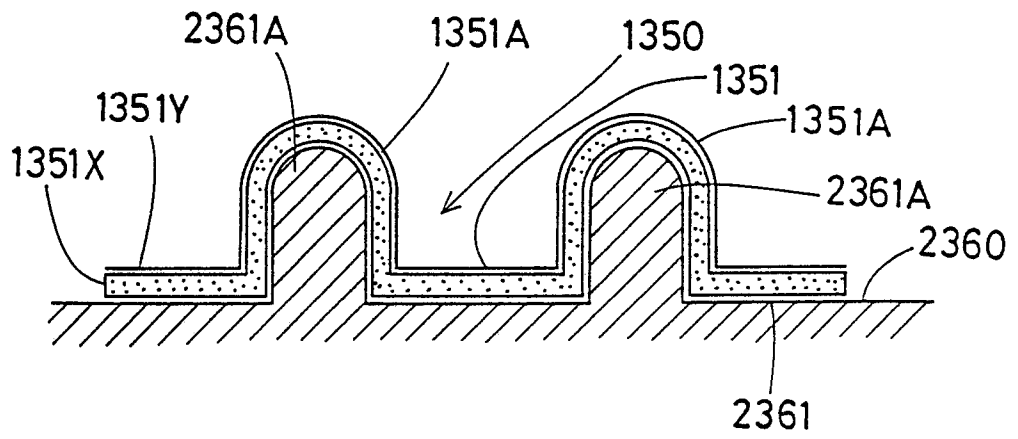

FIG. 68





DOCUMENTS CONSIDERED TO BE RELEVANT			
Category	Citation of document with indication, where appropriate, of relevant passages	Relevant to claim	CLASSIFICATION OF THE APPLICATION (Int. Cl.4)
Y	EP-A-0 207 720 (NAGOYA OILCHEMICAL CO., LTD) * Claims 1,2; figure 1 * ---	1,8	B 05 C 21/00 B 32 B 27/00 B 05 D 1/32
Y	GB-A-1 316 747 (SHELL) * Page 2, lines 22-29; page 3, lines 70-75; claim 9 * ---	1,8	
P,A	EP-A-0 248 652 (NAGOYA OILCHEMICAL CO., LTD) * Claims 1-3,5; figures 1-3,7-9 * ---	1,2	
P,A	EP-A-0 262 946 (NAGOYA OILCHEMICAL CO., LTD) * Claims 1,4,5,6; figure 1 * ---	1,3,8,9	
P,A	EP-A-0 263 637 (NAGOYA OILCHEMICAL CO., LTD) * Abstract; figure 1 * ---	1,4	
P,A	EP-A-0 256 782 (NAGOYA OILCHEMICAL CO., LTD) * Abstract; figures * ---	1,6	TECHNICAL FIELDS SEARCHED (Int. Cl.4)
A	FR-A-2 384 683 (DOURDIN) * Claims 1,8; figures * -----	1	B 32 B B 05 C
The present search report has been drawn up for all claims			
Place of search THE HAGUE		Date of completion of the search 13-12-1988	Examiner MCCONNELL C.H.
CATEGORY OF CITED DOCUMENTS X : particularly relevant if taken alone Y : particularly relevant if combined with another document of the same category A : technological background O : non-written disclosure P : intermediate document		T : theory or principle underlying the invention E : earlier patent document, but published on, or after the filing date D : document cited in the application L : document cited for other reasons ----- & : member of the same patent family, corresponding document	