



US 20230279669A1

(19) **United States**

(12) **Patent Application Publication**
WOLF et al.

(10) **Pub. No.: US 2023/0279669 A1**

(43) **Pub. Date: Sep. 7, 2023**

(54) **PREFABRICATED WALL PANEL WITH TONGUE AND GROOVE CONSTRUCTION**

10,329,775, which is a division of application No. 12/026,876, filed on Feb. 6, 2008, now Pat. No. 8,782,988.

(71) Applicant: **Westlake Royal Stone LLC**, Houston, TX (US)

Publication Classification

(72) Inventors: **David H. WOLF**, Newark, OH (US); **James S. BELT**, Utica, OH (US); **William SMITH**, Pataskala, OH (US); **Donn R. VERMILION**, Newark, OH (US); **Wayne J. BUONI**, New Albany, OH (US); **Joy STICKEL**, Columbus, OH (US)

(51) **Int. Cl.**
E04F 13/08 (2006.01)
E04F 13/14 (2006.01)
B29C 39/18 (2006.01)
B29C 39/36 (2006.01)
B29D 99/00 (2006.01)
E04F 15/02 (2006.01)

(73) Assignee: **Westlake Royal Stone LLC**, Houston, TX (US)

(52) **U.S. Cl.**
CPC *E04F 13/0894* (2013.01); *E04F 13/147* (2013.01); *B29C 39/18* (2013.01); *B29C 39/36* (2013.01); *B29D 99/001* (2013.01); *E04F 15/02038* (2013.01); *E04F 13/0873* (2013.01); *B29L 2031/10* (2013.01)

(21) Appl. No.: **18/315,958**

(22) Filed: **May 11, 2023**

Related U.S. Application Data

(60) Continuation of application No. 16/720,842, filed on Dec. 19, 2019, which is a continuation of application No. 16/447,624, filed on Jun. 20, 2019, now Pat. No. 10,557,273, which is a continuation of application No. 15/870,059, filed on Jan. 12, 2018, now Pat. No. 10,378,216, which is a continuation of application No. 14/879,827, filed on Oct. 9, 2015, now Pat. No. 9,903,124, which is a continuation of application No. 14/299,250, filed on Jun. 9, 2014, now Pat. No.

(57) **ABSTRACT**

A prefabricated wall panel has a precast body including at least one decorative design element. In addition, the wall panel includes a mounting element having a first end embedded in the precast body and a second end projecting from the precast body. A groove is formed between the precast body and the second end of the mounting element along a first edge of the precast body. A tongue is formed along a second edge of the precast body opposite the first edge. The tongue and groove cooperate to allow prefabricated wall panels to be more easily installed on a support substrate.

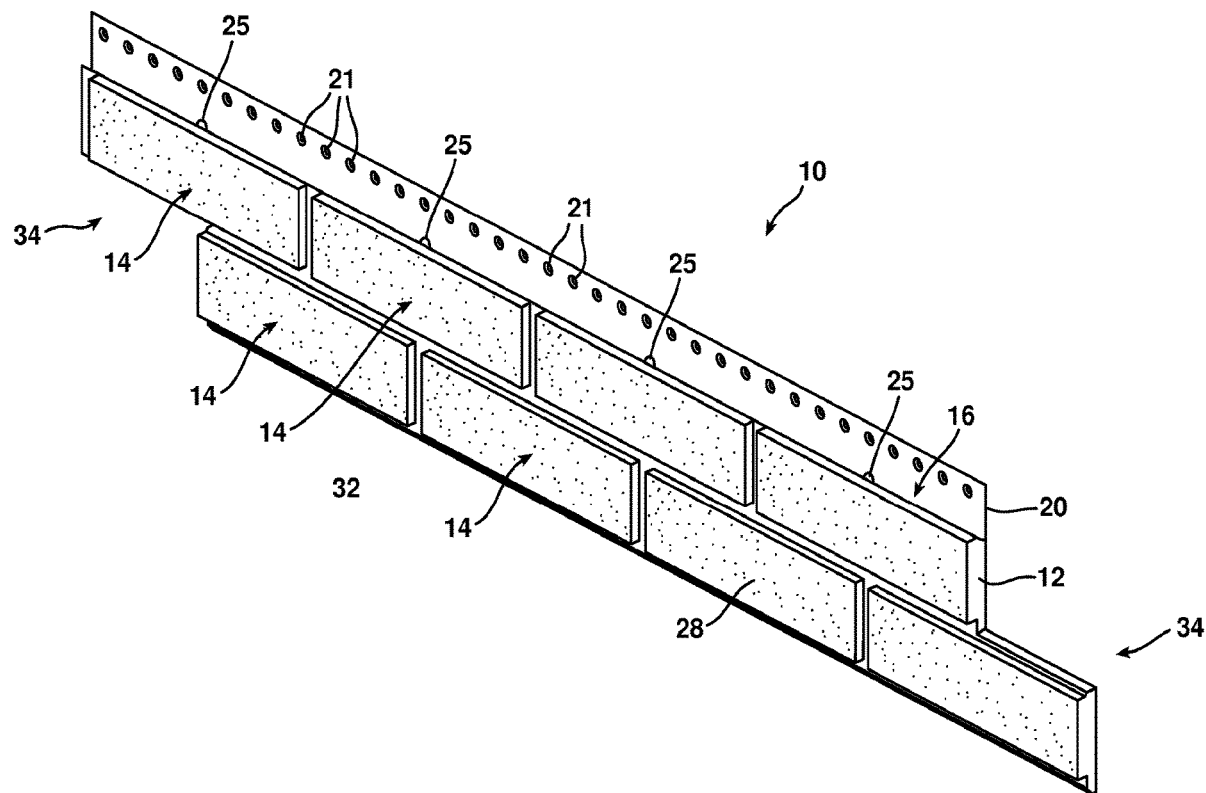

FIG. 1

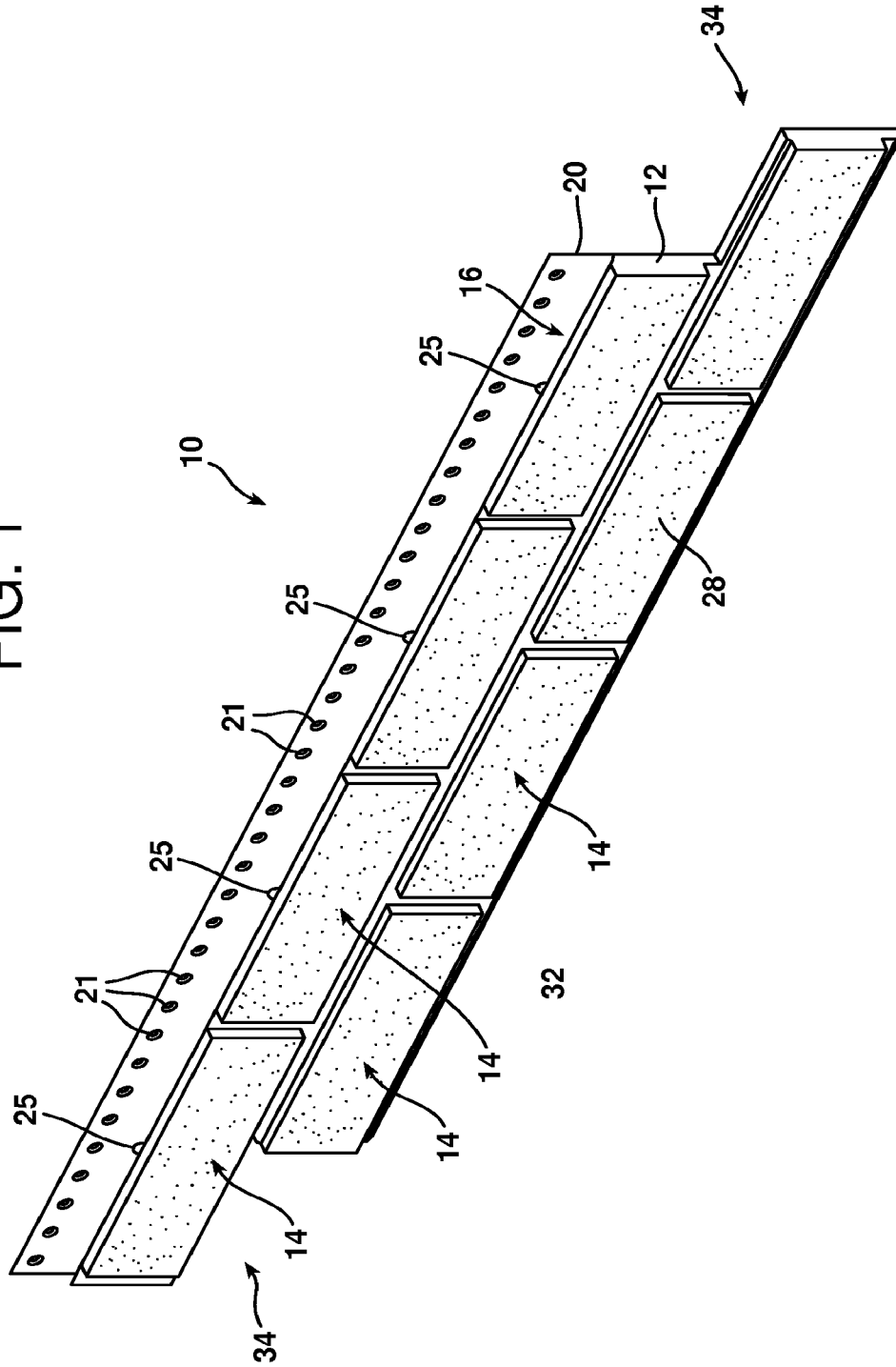

FIG. 2

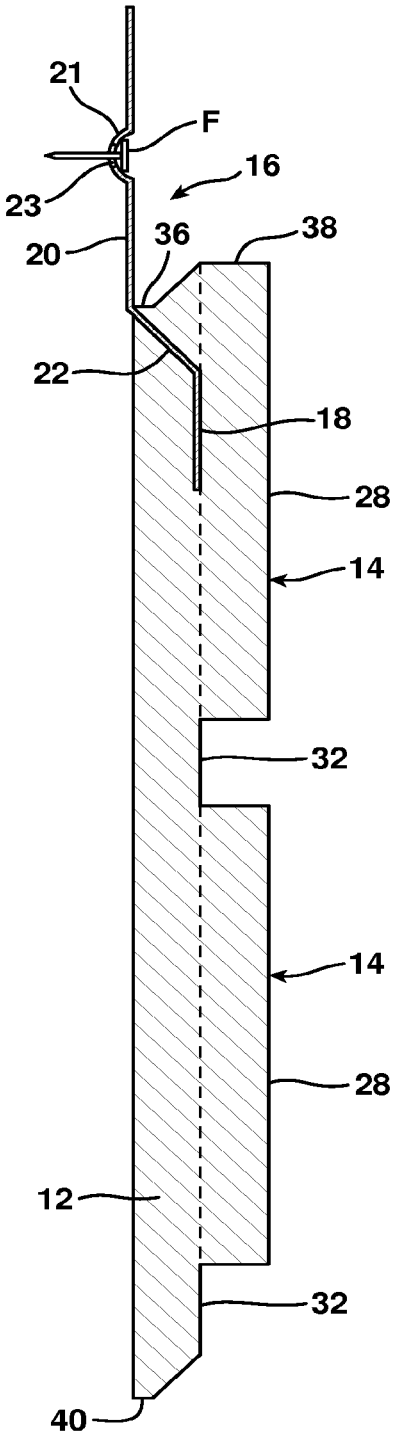

FIG. 3

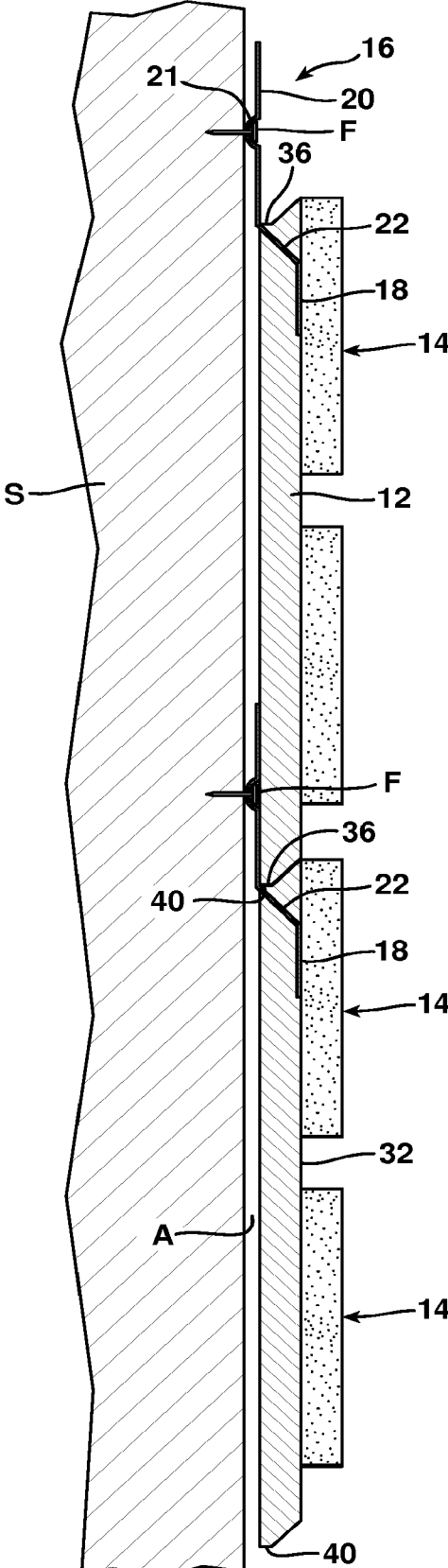

FIG. 4A

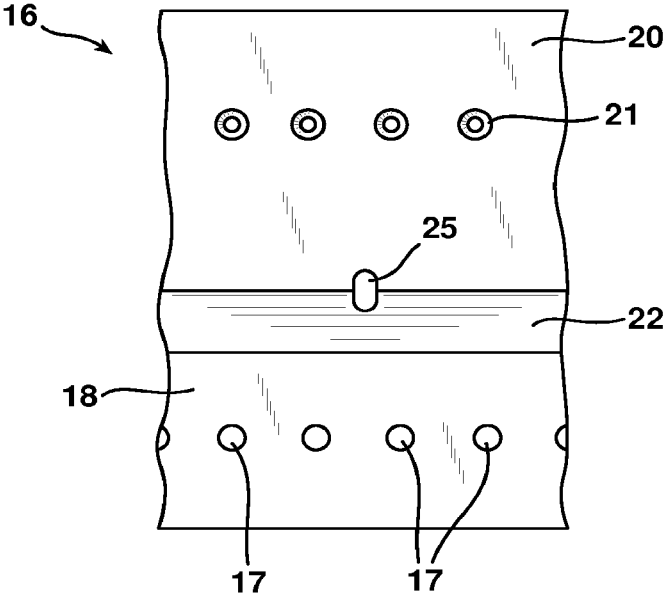

FIG. 4B

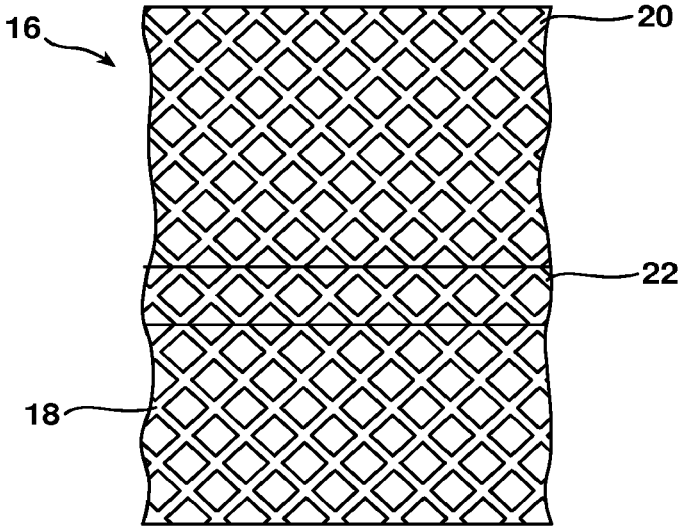

FIG. 4C

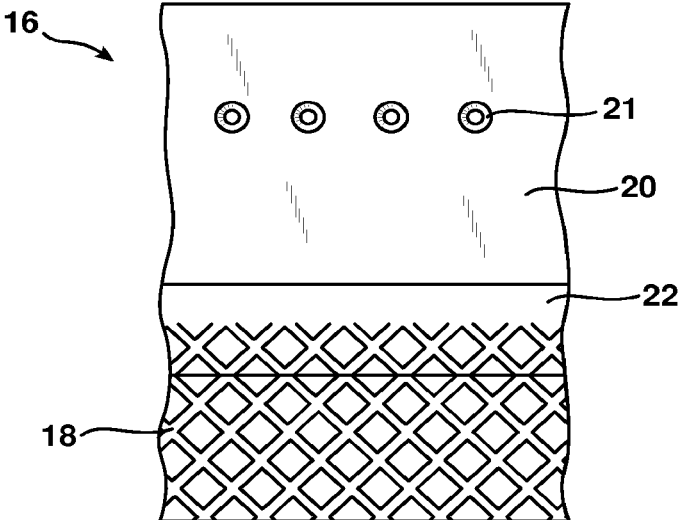

FIG. 4D

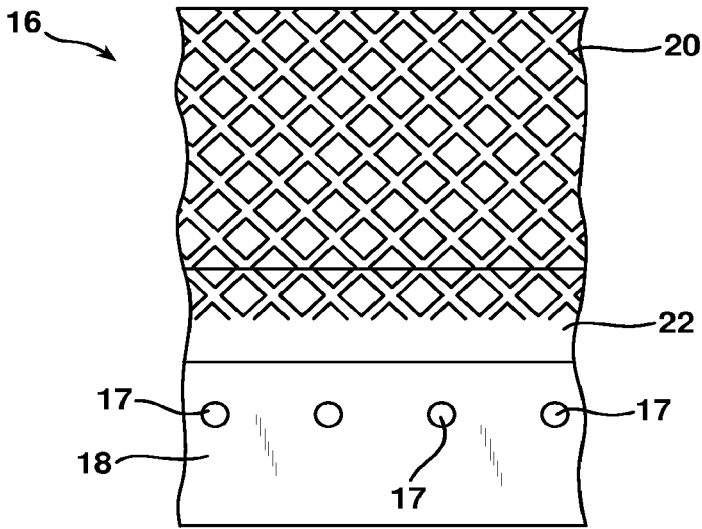

FIG. 5A

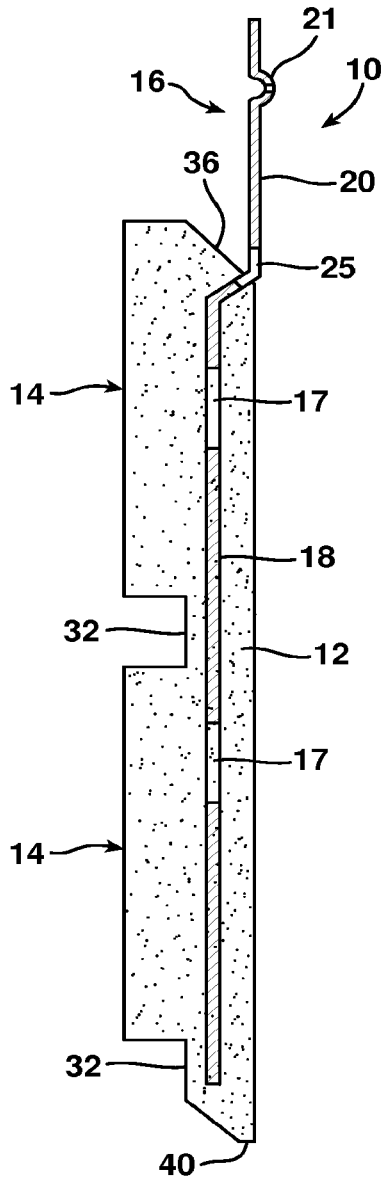

FIG. 5B

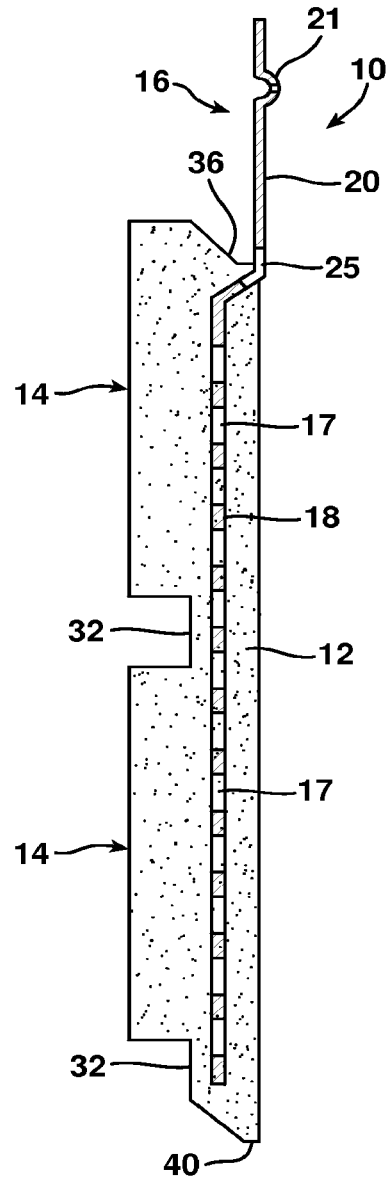

FIG. 5C

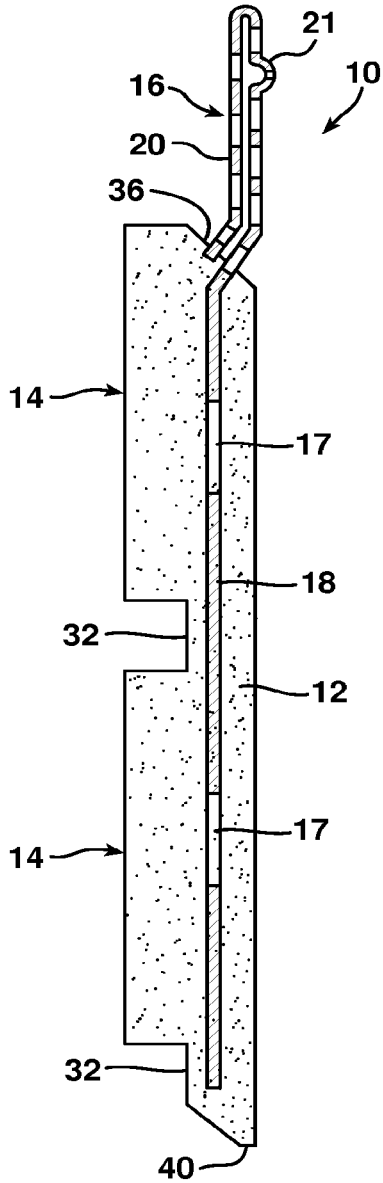

FIG. 5D

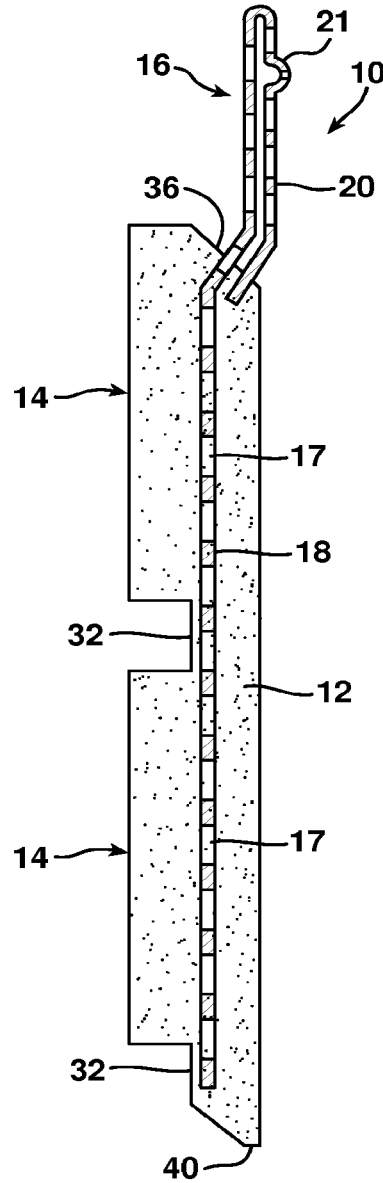

FIG. 5E

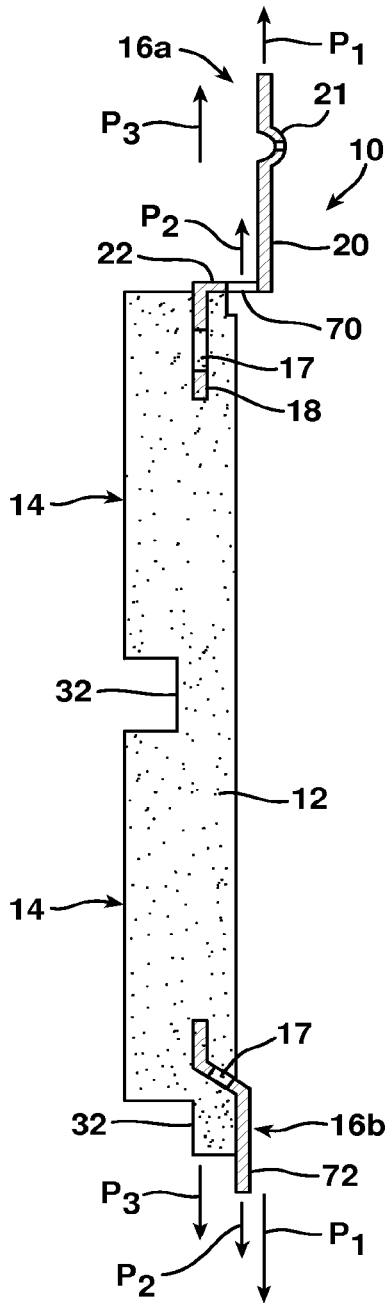

FIG. 5F

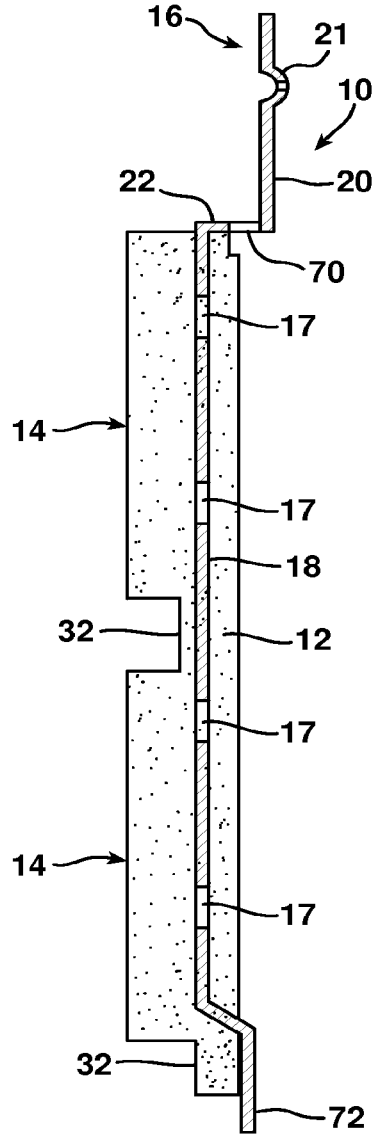
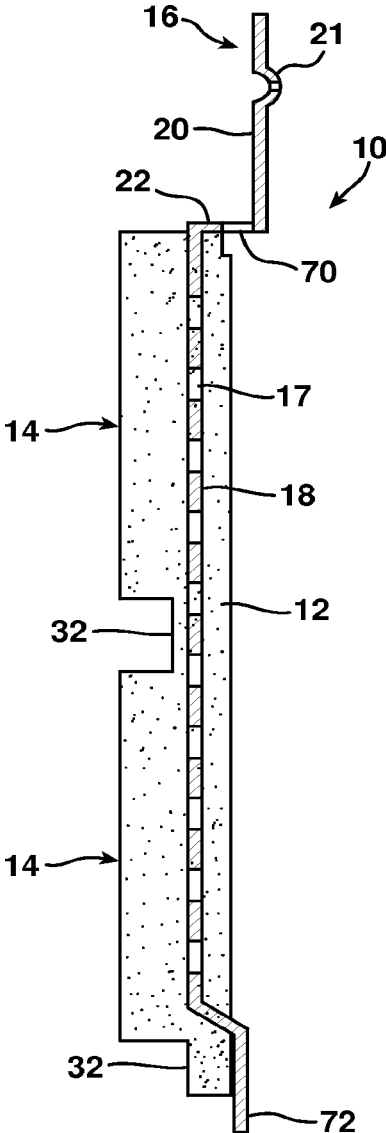

FIG. 5G



PREFABRICATED WALL PANEL WITH TONGUE AND GROOVE CONSTRUCTION

CROSS REFERENCE TO RELATED APPLICATIONS

[0001] This application is a continuation application of U.S. application Ser. No. 14/879,827, entitled “Prefabricated Wall Panel with Tongue and Groove Construction,” filed Oct. 9, 2015, which is a continuation application of U.S. application Ser. No. 14/299,250, entitled “Prefabricated Wall Panel with Tongue and Groove Construction,” filed Jun. 9, 2014, which is a divisional application of U.S. application Ser. No. 12/026,876, entitled “Prefabricated Wall Panel with Tongue and Groove Construction,” filed Feb. 6, 2008, and issued as U.S. Pat. No. 8,782,988 on Jul. 22, 2014, the contents of which are herein incorporated by reference in their entirety.

TECHNICAL FIELD

[0002] This invention relates generally to the construction field and, more particularly, to a prefabricated wall panel incorporating a mounting element.

BACKGROUND OF THE INVENTION

[0003] Prefabricated or cast veneer wall panels have been developed as a quick and efficient way to provide a masonry appearance for a building while simplifying construction and lowering construction cost. The design elements of prefabricated wall panels typically simulate brick, stone, tile and other masonry building components or materials commonly used in the construction of buildings. Examples of prefabricated wall panels are disclosed in U.S. Pat. No. 3,142,938 to Eberhardt, U.S. Pat. No. 4,669,238 to Kellis et al, U.S. Pat. No. 5,379,561 to Saito and U.S. Pat. No. 5,673,529 to Treister et al, in published U.S. Patent Application Serial No. 2007/0137128 to Viau et al and in Co-pending patent application Ser. No. 11/647,751 owned by the Assignee of the present invention.

[0004] Prefabricated wall panels are typically made from reinforced construction materials such as fiberglass reinforced concrete. Prefabricated wall panels made from such reinforced materials are resistant to damage to handling during packaging, shipping and installation. However, further improvements in durability to decrease loss due to breakage are still desired. The present invention relates to a prefabricated wall panel incorporating a mounting element to enhance durability and provide significantly improved handling characteristics as well as tongue and groove construction to simplify installation.

BRIEF SUMMARY

[0005] In accordance with the purposes of the present invention as described herein, an improved prefabricated wall panel is provided. The prefabricated wall panel comprises a precast body including at least one decorative design element and a mounting element including a first end embedded in the precast body and a second end projecting from the precast body. The wall panel includes at least one protrusion and at least one keying hole in the mounting element. The protrusion may take the form of a dimple and have an interior diameter of between approximately 0 and approximately 7.6 centimeters and a depth of between approximately 0.30 and approximately 0.35 centimeters. An

aperture is provided in the dimple. The aperture has a diameter of about 0.3175 centimeters and is concentrically positioned in the dimple. In addition, the wall panel includes at least one weep hole in the mounting element.

[0006] In one possible embodiment, the wall panel includes a groove formed between the precast body and the second end of the mounting element along a first edge of the precast body. In addition, a tongue is formed along a second edge of the precast body opposite the first edge. That tongue is formed by the precast body. The tongue is sized and shaped to be received in the groove so that prefabricated wall panels of the present invention may be vertically stacked and interconnected to form a wall.

[0007] The first end of the mounting element extends in a first plane and the second end of the mounting element extends in a second plane wherein the second plane is parallel to the first plane. The mounting element further includes a transition section that connects the first end to the second end and transitions between the first and second planes. In one possible embodiment the wall panel includes multiple decorative design elements and the groove is provided behind at least one of the multiple decorative design elements.

[0008] In accordance with an additional aspect of the present invention the mounting element is made from a material selected from a group consisting of metal, plastic, steel, corrosion resistant steel, aluminum, stainless steel, zinc, copper and combinations thereof. The mounting element is formed as a solid sheet, as a mesh or as a combination of solid sheet and mesh.

[0009] The precast body is made from a material selected from a group consisting of concrete, fiber reinforced concrete, gypsum, other cementitious materials and mixtures thereof. The precast body includes reinforcing fibers selected from a group of fibers consisting of glass fibers, mineral fibers, natural fibers, polymer fibers, E-glass fibers, AR-glass fibers and mixtures thereof.

[0010] In another possible embodiment, the wall panel includes a slot formed in the second end of the mounting element and a tab projecting from a second edge of the precast body opposite the first edge. The tab is formed by the mounting element. The mounting element may be one piece construction or two piece construction. In one embodiment the mounting element is at least one piece, in yet another embodiment the mounting element is at least two pieces. In one possible embodiment the mounting element is a solid body. In another possible embodiment at least a portion of the mounting element is mesh.

[0011] The tab is sized and shaped to be received in the slot so that prefabricated wall panels of the present invention may be interconnected to form a wall. The first end of the mounting element extends in a first plane, the second end of the mounting element extends in a second plane and the tab of the mounting element extends in a third plane between the first and second planes. In addition, the slot is provided in a transition section that connects the first and second ends of the mounting element. That slot also rests in the third plane.

[0012] In accordance with yet another aspect of the present invention a method is provided for forming a wall panel in a mold having a mold cavity. The method comprises the steps of: (a) positioning a mounting element with a first end extending into the mold cavity and a second end extending from the mold cavity; (b) adding casting material into the mold cavity so as to embed the first end of the mounting

element in the casting material; (c) forming a tongue in the mold cavity from casting material captured under a dimensional flap; (d) forming a groove in the mold between the casting material and the first end of the mounting element; (e) allowing the casting material to set; and (f) removing the wall panel from the mold. The method may also include adding casting material to the mold above a lower most surface of the dimensional flap. In addition, the method may include stretching the mold to free the tongue from under the dimensional flap while removing the wall panel from the mold.

[0013] In accordance with yet another aspect of the present invention, a mold is provided for forming a wall panel. The mold comprises a body including a mounting element support surface and a mold cavity. The body further includes a dimensional flap overlying a portion of the mold cavity. Still further, the mounting element support surface of the mold is provided along a first edge of a mold cavity and the dimensional flap is provided overlying a second edge of the mold cavity wherein the first edge is opposite the second edge.

[0014] In the following description there is shown and described several different embodiments of the invention, simply by way of illustration of some of the modes best suited to carry out the invention. As it will be realized, the invention is capable of other different embodiments and its several details are capable of modification in various, obvious aspects all without departing from the invention. Accordingly, the drawings and descriptions will be regarded as illustrative in nature and not as restrictive.

BRIEF DESCRIPTION OF THE DRAWINGS

[0015] The accompanying drawings incorporated herein and forming a part of the specification, illustrate several aspects of the present invention and together with the description serve to explain certain principles of the invention. In the drawings:

[0016] FIG. 1 is a front perspective view of the prefabricated wall panel of the present invention;

[0017] FIG. 2 is a cross-sectional view of the prefabricated wall panel illustrated in FIG. 1;

[0018] FIG. 3 is a partially schematical and cross sectional view illustrating the mounting of two wall panels, one above the other, along a support substrate such as a wall stud;

[0019] FIGS. 4A-4D are fragmentary front elevational views of four different mounting elements used in the prefabricated wall panel of the present invention;

[0020] FIGS. 5A-5G are schematical sectional views illustrating several different embodiments of the wall panel of the present invention; and

[0021] FIG. 6 is a cross sectional view of the mold in which the wall panel of FIGS. 1 and 2 are formed.

[0022] Reference will now be made in detail to the present preferred embodiments of the present invention examples of which are illustrated in the accompanying drawings.

DETAILED DESCRIPTION

[0023] Reference is now made to FIG. 1 illustrating the prefabricated wall panel 10 of the present invention. Such a wall panel 10 may be used as a wall cladding for a building. Further applications include but are not limited to the construction of a fireplace surround or an outdoor living component such as a decorative wall or grill surround.

[0024] The prefabricated wall panel 10 comprises a precast body 12 including at least one decorative design element 14. As illustrated the design element 14 comprises two rows of overlapping brick with four brick in each row. It should be appreciated that substantially any other masonry material known in the art may be simulated including bricks of different sizes, stones of the same or different sizes and shapes, tiles of different sizes and shapes and the like.

[0025] The precast body 12 is made from a cast material such as concrete, reinforced concrete, gypsum, fiber reinforced gypsum, polymer modified gypsum, reinforced cementitious material and mixtures thereof. Typically the cast material reinforcement comprises fibers selected from a group of materials consisting of glass fibers, carbon fibers, mineral fibers, natural fibers, polymer fibers and mixtures thereof. Where glass fibers are used they are typically of the E-glass or AR-glass type which exhibits some alkali resistance.

[0026] As best illustrated in FIGS. 1 and 2, the prefabricated wall panel 10 also includes a mounting element, generally designated by reference numeral 16. The mounting element 16 may be made from a material selected from a group consisting of wood, concrete, cellulose fiber board, polymer material, composite material, metal, plastic, reinforced plastic, thermoplastic, fiber composite, reinforced wood, steel, corrosion-resistant steel, aluminum, stainless steel, zinc, copper and combinations thereof. The corrosion-resistant steel may take any number of forms including, but not limited to, galvanized, galvaneal, Galvalume™ brand, tin coating, chromium coating, nickel coating, phosphorous coating, magnesium coating, copper coating, zinc coating, weathering steels (i.e., alloys of steel with small additions of copper, aluminum, nickel and/or phosphorous), polymer coatings and paint.

[0027] Polymer materials useful for the making of the mounting element 16 include various thermoplastic and thermoset resins including but not limited to polyolefins, polyesters, polyvinylchloride, polypropylene, polyethylene, polyamide, epoxy, vinyl ester, acrylic, polystyrene, ABS, melamine and mixtures thereof. Composite materials used to make the mounting element 16 include a reinforcing material and a matrix binder. Appropriate reinforcing materials useful in the present invention include but are not limited to glass fibers, natural fibers, mineral fibers, basalt fibers, carbon fibers, kenaf fibers, jute fibers, hemp fibers, E-glass fibers, C-glass fibers, R-glass fibers, S-glass fibers, ECR-glass fibers, AR-glass fibers and mixtures thereof. It should be appreciated that substantially any type of glass fiber may be used for reinforcement fibers. Glass fibers appropriate for use in the present invention may be loose chopped strand or glass mat and include those available under the trademark ADVANTEX. Matrix binder materials useful for this purpose include but are not limited to polyolefins, polyesters, polyvinylchloride, polypropylene, polyethylene, polyamide, epoxy, vinyl ester and mixtures thereof.

[0028] As best illustrated in FIG. 2, the mounting element 16 includes a first end 18 that is embedded in the precast body 12 and a second end 20 that projects from the precast body. This may be accomplished by positioning the mounting element 16 so that the first end 18 projects into the mold cavity in which the body 12 is cast. After positioning the mounting element 16, the cast material is sprayed, injected or otherwise added to the mold. The cast material of the body 12 covers the front and the rear major faces of the first

end 18 of the mounting element 16. When set, the body 12 securely holds the mounting element 16 in position. Typically, the first end 18 includes a series of spaced keying holes 17. These holes 17 fill with the cast material and ensure that the mounting element 16 is firmly seated and secured in the cast body 12 once the material sets.

[0029] As illustrated in FIGS. 1 and 2, the second end 20 of the mounting element 16 projects upwardly from the top edge of the precast body 12. In the illustrated embodiment, the mounting element 16 includes a transition section 22 connecting the first end 18 with the second end 20. In one embodiment, the transition section 22 forms an included angle of between 0° and about 180°. In another embodiment, as illustrated in FIG. 2, the transition section 22 forms an included angle of between about 130° and about 140° and most typically 135° with the first end 18.

[0030] As further illustrated in FIG. 1, the second end 20 of the mounting element 16 may include a series of protrusions 21. The protrusion 21 may take the form of dimples, slots, ribs or any other structure that provides a set back means and can receive a nail or fastener. In the illustrated embodiment, the protrusion 21 is a dimple. The dimples 21 project away from the front face 28 of the wall panel 10. The dimples 21 function to provide an air space A between the wall panel 10 and the sheathing S or other building substrate to which the wall panel 10 is fastened. The wall panel 10 is fastened or secured to the sheathing S by means of fasteners such as nails or screws F (see FIGS. 2 and 3) that are received and pass through the recessed apertures 23 provided along the second end 20 of the mounting element 16.

[0031] Typically, each dimple 21 has an interior diameter of between approximately 0 and approximately 7.6 centimeters. More typically, each dimple 21 has an interior diameter of between about 2.5 and about 7.6 centimeters. Still more typically each dimple 21 has an interior diameter of between about 2 to about 5 centimeters. For many applications, each dimple 21 has an interior diameter of between about 1.0 and about 1.6 centimeters.

[0032] Each dimple also has a depth of between approximately 0.30 and approximately 0.60 centimeters. The aperture 23 in each dimple 21 typically has a diameter of about 0.3175 centimeters. Further, the aperture 23 is concentrically received in the bottom of the dimple 21. Advantageously, the diameter of the dimple 21 allows the head of a fastener, such as a roofing nail, to fit inside the dimple where it will not interfere with the mounting of the next panel. The aperture 21 insures the centering of the nail in the dimple. The bottom wall of the dimple 21 is also slightly curved as illustrated. The size and shape of the dimple 21 insures that the dimple does not collapse or become embedded in the underlying sheathing during installation of the wall panel 10. In this way good ventilation is insured between the wall panel and the underlying sheathing to which it is mounted as discussed in detail below.

[0033] In order to complete a wall, it is necessary to vertically stack a series of prefabricated wall panels 10. Each additional row of wall panels 10 is offset with respect to the previous row by the staggered ends 34 provided on the panels in a manner well known in the art. As each succeeding wall panel 10 in each succeeding row is added (see FIGS. 2 and 3), a tongue and groove arrangement ensures proper placement and greatly simplifies installation.

[0034] More specifically, each wall panel 10 includes a groove 36 formed between the precast body 12 and the front

face of the second end 20 of the mounting element 16. The groove 36 is provided in or along the first or top edge 38 of the precast body 12. In the illustrated embodiment, a cooperating tongue 40 is formed by the second or bottom edge of the precast body 12. In alternative embodiments, the tongue 40 could be formed by a metal backer or other similar structure. During installation, the tongue 40 on one wall panel 10 is precisely sized and shaped to be received in the cooperating groove 36 on the underlying wall panel 10. This interconnection ensures proper registration between wall panels 10 during installation. Further, the tongue and groove connection between the wall panels 10 functions to support the wall panel being added in proper position until fasteners F can be positioned in the support substrate S through the recessed apertures 21 to hold the panel in place. Grout is then provided in the grout areas 32 between the design elements 14 on all of the wall panels 10 in order to complete the installation. Weep holes 25 are provided at spaced locations in the second end 18 of the mounting element 16 adjacent the transition section 22. These weep holes 25 allow water to drain from the groove 36. In the illustrated embodiment, a weep hole 25 is provided at the center of each brick design element 14. In another embodiment, the weep hole 25 may not be at the center of each brick design element 14.

[0035] As best illustrated in FIGS. 4A-4D, the mounting element 16 may take a number of forms. As illustrated in FIGS. 1, 2, 3 and 4A, the first end 18 and second end 20 may both be made from a solid piece of material. Alternatively, as illustrated in FIG. 4B, the two ends 18, 20 may both be made from a mesh material (i.e. any perforated material), such as, galvanized steel, aluminum and/or copper. As yet another alternative, FIG. 4C illustrates an embodiment wherein the first end 18 is made from a mesh material and the second end 20 is made from a solid material. In contrast, FIG. 4D illustrates an embodiment where the first end 18 is made from a solid material and the second end 20 is made from a mesh material.

[0036] The use of mesh material instead of solid material serves a number of advantages. Good strength is obtained yet less material is used thereby reducing costs of production. Where the first end 18 is made of mesh material, the interlocking of the mounting element 16 in the precast body 12 is enhanced. This is because the cast material is received in and passes through each of the openings in the mesh to provide a most secure interconnection.

[0037] Alternative embodiments for the wall panel 10 are illustrated in FIGS. 5A-5G. In FIG. 5A, the first end 18 of the mounting element 16 is long enough to extend nearly to the end of the tongue 40. This provides added strength to the precast body 12. In this embodiment, the first end 18 of the mounting element 16 is made from solid material including a few spaced keying holes 17 for receiving cast material. In the embodiment illustrated in FIG. 5B, the first end 18 is made from mesh material.

[0038] FIG. 5C illustrates a wall panel 10 incorporating a mounting element 16 with a second end 20 constructed from mesh material and an extended first end 18 constructed from solid material but incorporating several keying holes 17. FIG. 5D illustrates yet another alternative embodiment wherein the entire mounting element 16 is made from mesh material including the first end 18.

[0039] FIGS. 5E-5G illustrate additional alternative embodiments. In FIG. 5E, the mounting element 16 is made

from two separate pieces (NOTE: It could be made of three, four or more pieces if desired). The first piece **16a** of the mounting element includes a first end **18** embedded in the precast body **12** and extending in a first plane P_1 , a second end **20** projecting from the precast body **12** and extending in a second plane P_2 and a transition section **22** connecting the first and second ends **18** and **20**. As further illustrated, the first end includes a keying hole **17** that receives the cast material to ensure that the first piece of the mounting element **16a** is securely held in position by the precast body. The second end **20** includes at least one dimple **21** as described above. In addition, the transition section **22** includes a slot **70**.

[0040] As further illustrated in FIG. 5E, a second mounting element **16b** forms a tab **72** projecting from a second edge of the precast body **12**. The second piece of the mounting element **16b**, like the first piece of the mounting element **16a**, includes a keying hole **17** to receive cast material and insure it is securely held in the precast body **12**. As illustrated, the slot **70** and the tab **72** both extend in a third plane P_3 between the first and second planes P_1P_2 . Accordingly, a second wall panel **10** may be added to a first wall panel **10** previously secured to a substrate by aligning and inserting the tabs **72** on the second wall panel into the slots **70** on the first wall panel. Thus, the slots and tabs **70**, **72** function like the tongue and grooves **40**, **36** on the embodiments in FIGS. 1 and 2 to align and secure wall panels **10** together.

[0041] FIG. 5F shows yet another alternative embodiment of the slot and tab **70**, **72** construction. In this embodiment the mounting element **16** is a single piece incorporating a series of keying holes **17** to allow it to be firmly secured in the precast body **12**. This single piece mounting element **16** provides additional strength to the precast body **12**.

[0042] In the additional embodiment illustrated in FIG. 5G, a single piece mounting element **16** is again illustrated incorporating the slot **70** and groove **72** connection system. Unlike the embodiment illustrated in FIG. 5F, in the embodiment illustrated in FIG. 5G, a portion **74** of the mounting element **16** embedded in the precast body **12** is made from a mesh material.

[0043] A mold **50** for forming a wall panel **10** is illustrated in FIG. 6. The mold **50** comprises a mold body **52** formed from an elastomeric material such as silicone, urethane, polyurethane, and/or latex. The mold body **52** includes a mounting element support surface **54**, a mold cavity **56** and a dimensional flap **58** overlying a portion of the mold cavity that forms the tongue **40**. Sufficient casting material may be added to the mold **50** above a lowermost surface **39** of the dimensional flap **58** to insure the groove **36** is formed to proper shape. More specifically, the mounting element support surface **54** is provided along a first edge **60** of the mold cavity **56** while the dimensional flap **58** is provided along a second opposite edge **62** of the mold cavity.

[0044] The wall panel **10** is produced by positioning a mounting element **16** onto the support surface **54** with the first end **18** extending into the mold cavity **56** and the second end **20** extending from the mold cavity. Casting material may be added to the mold cavity **56** before and/or after positioning the mounting element **16** onto the support surface **54**. This may be done by injecting, spraying or any other means known in the art. During this step, the first end **18** of the mounting element **16** is embedded in the casting material.

[0045] The method also includes the step of forming the tongue **40** in the mold cavity **56** from casting material captured under the dimensional flap **58**. Still further, the method includes forming the groove **36** in the mold **50** between the precast body **12** and the second end **20** of the mounting element **16**. After allowing the cast material to set, the wall panel **10** is removed from the mold **50**. This may be done by stretching the mold body **52** to free the tongue **40** from under the dimensional flap **58**.

[0046] The foregoing description of the preferred embodiments of the present invention have been presented for purposes of illustration and description. It is not intended to be exhaustive or to limit the invention to the precise form disclosed. Obvious modifications or variations are possible in light of the above teachings. For example, in the illustrated embodiments, the apertures **23** for receiving a fastener are provided in the protrusion **21**. In alternative embodiments, such apertures **23** may be provided substantially anywhere in the body **12**. As another example, the illustrated embodiment of FIG. 5E includes a mounting element **16** with a first end **18** extending in a first plane P_1 and a second end **20** extending in a second plane P_2 where the planes P_1 and P_2 are parallel to one another. The mounting element **16** could include ends that extend in planes that are not parallel to one another.

[0047] The embodiments were chosen and described to provide the best illustration of the principles of the invention and its practical application to thereby enable one of ordinary skill in the art to utilize the invention in various embodiments and with various modifications as are suited to the particular use contemplated. All such modifications and variations are within the scope of the invention as determined by the appended claims when interpreted in accordance with the breadth to which they are fairly, legally and equitably entitled. The drawings and preferred embodiments do not and are not intended to limit the ordinary meaning of the claims in their fair and broad interpretation in any way.

1-9. (canceled)

10. A wall panel, comprising:

a precast body including a design element, the precast body having opposing edges; and

a mounting element, comprising:

a tab projecting beyond one edge of the opposing edges of the precast body; and

an end projecting beyond the other edge of the opposing edges of the precast body, the end defining a slot.

11. The wall panel of claim 10, wherein the wall panel is configured to interconnect with an adjacent wall panel to form a wall.

12. The wall panel of claim 11, wherein the slot is configured to receive a tab of the adjacent wall panel.

13. The wall panel of claim 10, wherein the tab extends in a first plane and wherein the slot in the end is in the same plane as the tab.

14. The wall panel of claim 10, wherein the tab extends in a first plane, and wherein the end extends in a second plane parallel to the first plane.

15. The wall panel of claim 14, wherein the mounting element further comprises a transition section that that connects the tab and the end.

16. The wall panel of claim 15, wherein the transition section transitions between the first plane and the second plane.

17. The wall panel of claim 10, wherein the mounting element is a single piece extending through the precast body.

18. The wall panel of claim 10, wherein the mounting element is a single piece affixed to the precast body.

19. The wall panel of claim 10, wherein the mounting element comprises more than one piece.

20. The wall panel of claim 10, wherein the end further comprises one or more apertures for receiving a nail or fastener.

21. The wall panel of claim 10, wherein the mounting element further comprises a hole or gap to allow water to drain between the wall panel and a wall to which the wall panel is attached.

* * * * *