

3

1

2 (a)(b)(c)

(a)

(b)

(c)

3

4

5

-

20 - , 22 - ,

24 - "□ ' , 26 - ,

28 - .

가

(5) ,) (1) 1 (3) , (2)가 (2)

(5) (4) 2 (a) (6) 가 , (1) (5) , (8)

(9) (10) (7) (6) (11)

(12) (12) (13) .

(8) (12) (14) (15)가 2 (b) (16)

(9) (10) (10) (17) , (9)

(7) (13)가 (4) (12) (11)

(7) (6)가 (10) 2 (c) (8)

(7) (7) (6) (15) (1) (14) (9)

(1)

(7)가 가 (5) , (7) (14) 가 (6) 가

(10) (10) (7) (4) (5) , 가

(10) (7) (9) (10) 가 (7) (10)

가

가

가 "ㄷ" 가 ,

가 (가

가

3 , 5 , 4 , 가 , 가
(20) (26) , (20) (22) "ㄷ" (24)가
(28) (9) (9)
40 (4) (6) , 42 (5)
(6)
3 (1) (5) (6)가
(6) (7) 가 (20)
(8) (9) (20) (22) "ㄷ" (24)가 , (28)
(7)가 (20) (26) , (26) (4)
() () , 가
(7) (4) (20) 4 (6) (9) (8) (7)가 ,
(11) 5 (13) 가 (5) (42)
(13)가 (4) (12) (13) 가 (11)
20) (17) , (7) 가 (9) ()
(20) (28) (7) () , (7) 가 (20)
(5) (4) (1) (20) "ㄷ" (24)
(1) (4) (1) (4)
(20) (24) "ㄷ" (4) (24) , (1) (4)
(4) (6) (5) (7) "ㄷ"
(24) (20) (7) "ㄷ"
(26)

(26) (7) (8) (20) (7) (7)가 (7) ,
 (28) (26) (20) (22) "ㄷ" (24)가 (20) ,
 (4) (20) (9) (9) (9) (24)
 (20) (26) "ㄷ" (7)가 (7)가
 (7)가 (26) 가 (7)가

(57)

1.

가 , 가 (2) (28)
 (20) (22) "ㄷ" (24)가 (20) (28)
 (20) (9) (9)

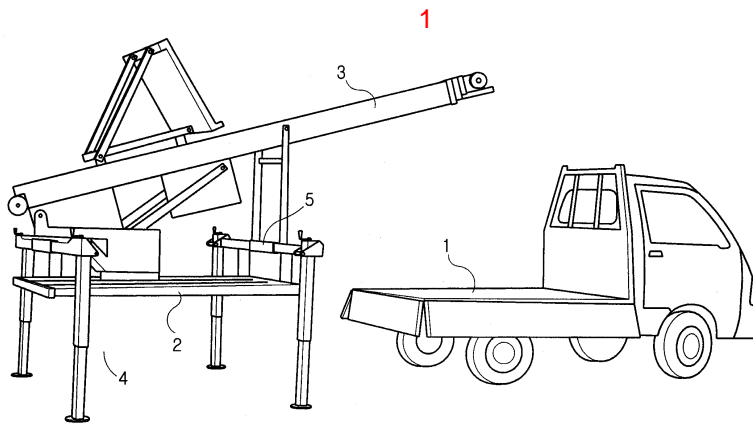

2a

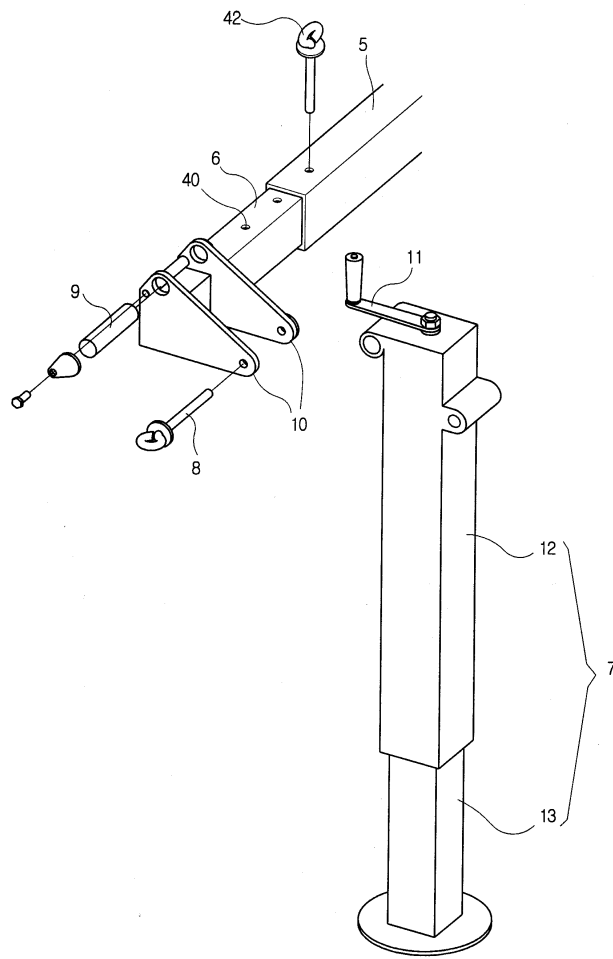

2b

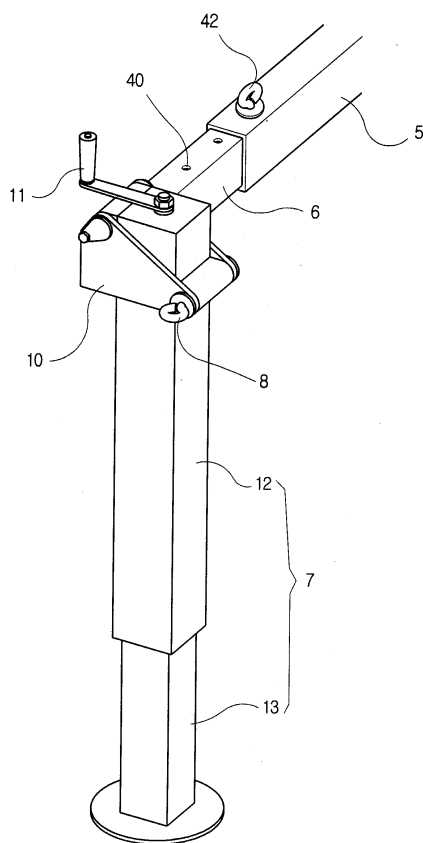

2c

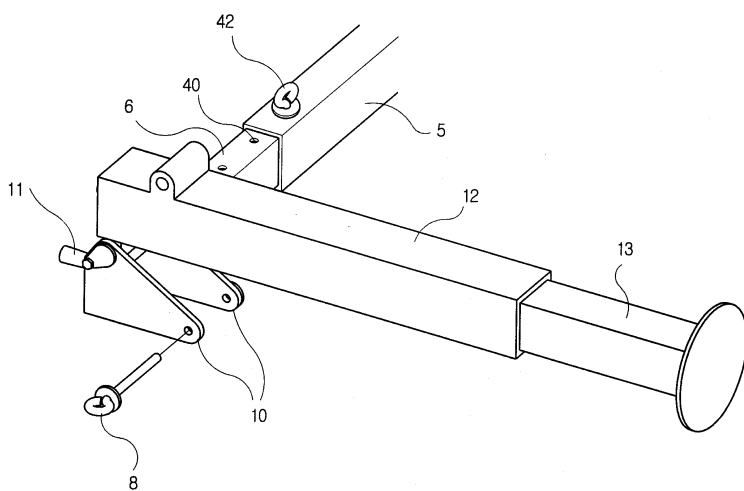

3

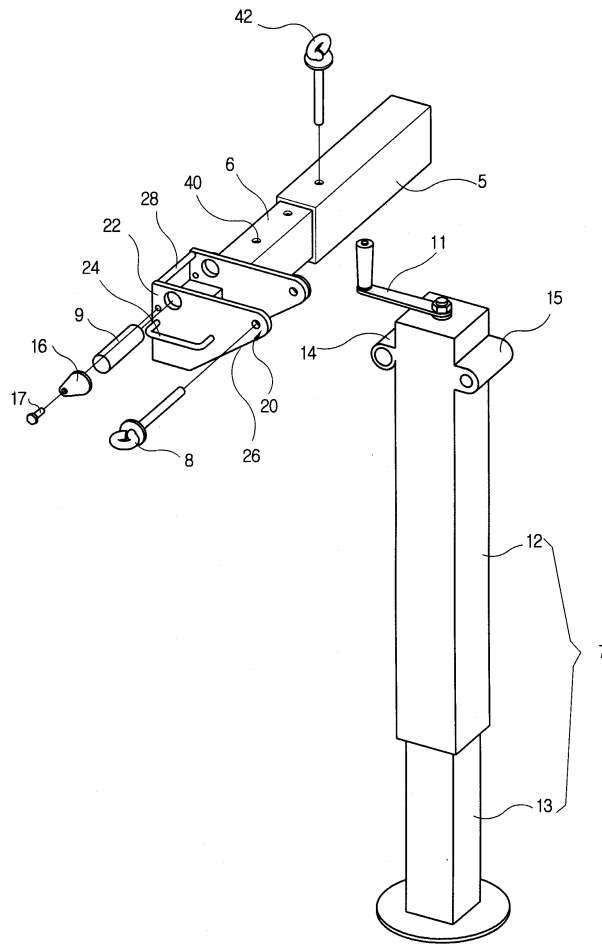

4

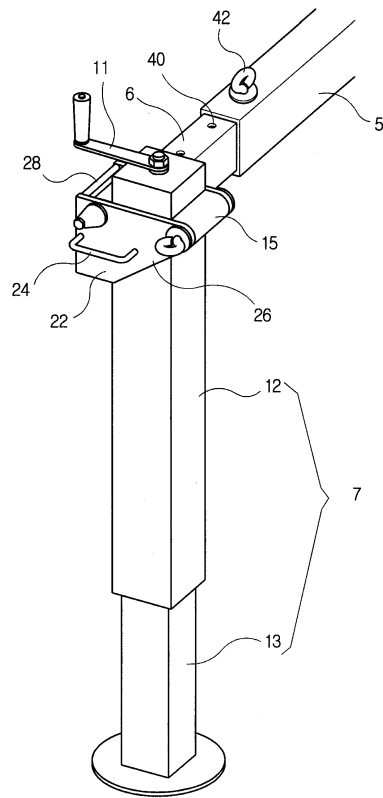

5

