



## INTERNATIONAL APPLICATION PUBLISHED UNDER THE PATENT COOPERATION TREATY (PCT)

<p>(51) International Patent Classification <sup>5</sup> : <b>H01Q 15/00, 13/02, H01P 3/12</b></p>	<p><b>A1</b></p>	<p>(11) International Publication Number: <b>WO 94/00892</b> (43) International Publication Date: 6 January 1994 (06.01.94)</p>
<p>(21) International Application Number: PCT/GB92/01173 (22) International Filing Date: 29 June 1992 (29.06.92)</p> <p>(71) Applicant (for all designated States except US): LOUGHBOROUGH UNIVERSITY OF TECHNOLOGY [GB/GB]; Loughborough, Leicestershire LE11 3TF (GB).</p> <p>(72) Inventors; and (75) Inventors/Applicants (for US only) : VARDAXOGLU, John, Costas [GB/GB]; 63 William Street, Loughborough, Leicestershire LE11 3BX (GB). SEAGER, Robert, Dennis [GB/GB]; 6 Linden Road, Loughborough, Leicestershire LE11 1PG (GB). ROBINSON, Alan, John [GB/GB]; 30 New Street, Hephthorne Lane, North Wingfield, Chesterfield, Derbyshire S42 5JW (GB).</p>		<p>(74) Agents: RAYNOR, Simon, Mark et al.; Abel &amp; Imray, Northumberland House, 303-306 High Holborn, London WC1V 7LH (GB).</p> <p>(81) Designated States: JP, US, European patent (AT, BE, CH, DE, DK, ES, FR, GB, GR, IT, LU, MC, NL, SE).</p> <p><b>Published</b> <i>With international search report.</i></p>
<p>(54) Title: A WAVEGUIDE AND AN ANTENNA INCLUDING A FREQUENCY SELECTIVE SURFACE</p>		
<p>(57) Abstract</p> <p>A waveguide (4) includes two frequency selective surfaces (5) mounted within the waveguide parallel to its side walls (6). The frequency selective surfaces (5) influence the frequency response of the waveguide (4).</p>		

**FOR THE PURPOSES OF INFORMATION ONLY**

Codes used to identify States party to the PCT on the front pages of pamphlets publishing international applications under the PCT.

AT	Austria	FR	France	MR	Mauritania
AU	Australia	GA	Gabon	MW	Malawi
BB	Barbados	GB	United Kingdom	NE	Niger
BE	Belgium	GN	Guinea	NL	Netherlands
BF	Burkina Faso	GR	Greece	NO	Norway
BG	Bulgaria	HU	Hungary	NZ	New Zealand
BJ	Benin	IE	Ireland	PL	Poland
BR	Brazil	IT	Italy	PT	Portugal
BY	Belarus	JP	Japan	RO	Romania
CA	Canada	KP	Democratic People's Republic of Korea	RU	Russian Federation
CF	Central African Republic	KR	Republic of Korea	SD	Sudan
CG	Congo	KZ	Kazakhstan	SE	Sweden
CH	Switzerland	LI	Liechtenstein	SI	Slovenia
CI	Côte d'Ivoire	LK	Sri Lanka	SK	Slovak Republic
CM	Cameroon	LU	Luxembourg	SN	Senegal
CN	China	LV	Latvia	TD	Chad
CS	Czechoslovakia	MC	Monaco	TG	Togo
CZ	Czech Republic	MG	Madagascar	UA	Ukraine
DE	Germany	ML	Mali	US	United States of America
DK	Denmark	MM	Mongolia	UZ	Uzbekistan
ES	Spain			VN	Viet Nam
FI	Finland				

A waveguide and an antenna including  
a frequency selective surface.

The present invention relates to a waveguide including a frequency selective surface and an antenna including a frequency selective surface. More specifically, the invention relates to a tuneable multiband/broadband wave guiding system and aperture antenna.

Waveguides and antennas for electromagnetic radiation are generally designed to operate at one specific frequency or within a narrow frequency band. The aim of the present invention is to provide a waveguide and an antenna that have broad or multiple operating frequency bands. It is a further aim of the invention to provide a waveguide and an antenna that are tuneable to operate at different frequencies.

According to the present invention, there is provided a waveguide including a frequency selective surface, the frequency selective surface being arranged to influence the frequency response of the waveguide.

A frequency selective surface (FSS) is an array of antenna elements that acts as a passive electromagnetic filter. The surface may comprise an array of electrically conductive elements on a dielectric substrate or, alternatively, a plurality of apertures in a conductive surface. Electromagnetic waves incident on a surface comprising an array of conductive elements are reflected from the surface only in a narrow band of frequencies and

are transmitted at other frequencies. With an array of apertures, electromagnetic waves are transmitted only in a narrow band of frequencies. Such surfaces are used as multiplexers or radomes in communications systems and  
5 can operate at microwave frequencies, including mm-waves, up to infrared and optical frequencies.

At least one frequency selective surface may be mounted within the waveguide, to divide the waveguide longitudinally into two or more parts. Preferably, the  
10 frequency selective surface is parallel to a side wall thereof. Mounting a frequency selective surface within a waveguide allows the effective dimensions of the waveguide to vary with the operating frequency, thereby providing broad or multiple operating frequency bands.

15 Alternatively, the frequency selective surface may be provided over an open end of the waveguide.

The present invention further provides an antenna for microwave radiation, comprising a outer horn and an inner horn, wherein at least the inner horn includes a  
20 frequency selective surface. The outer horn or horns may also comprise frequency selective surfaces.

The frequency selective surface may be either reconfigurable or non-reconfigurable. Non-reconfigurable frequency selective surfaces are designed to operate in a  
25 particular frequency range, which is determined by the size and the arrangement of the antenna elements and the size of the array. The operating frequency of a non-reconfigurable frequency selective surface cannot be

changed.

A reconfigurable frequency selective surface comprises at least two arrays of elements, the arrays being arranged in close proximity with one another so that elements of a first array are closely coupled with elements of a second array adjacent to the first array. The first array is displaceable with respect to the second array to adjust the frequency response of the surface.

10 The first and second arrays may be substantially parallel with one another.

The array elements may be conductive elements on a dielectric substrate, or apertures in a conductive substrate, or a combination of the above.

15 The first and second arrays may have a separation of no more than 0.03 wavelengths, and preferably no more than 0.003 wavelengths of the electromagnetic waves having the resonant frequency of the surface. For example, when microwaves of frequency 30GHz are to be reflected, the separation is advantageously no more than 0.225mm and preferably no more than 0.025mm.

25 The first array may be displaceable relative to the second array in a direction parallel to the surfaces of the arrays. Alternatively, the frequency selective surface may be reconfigured by rotating the first array with respect to the second array, or by altering the distance and/or the medium separating the first array from the second array. Using that configuration, there

is no limit to the distance separating the arrays.

The array elements may be parallel linear dipoles, and the at least one array may be displaceable in the longitudinal direction of the linear dipoles.

5        Embodiments of the invention will now be described, by way of example, with reference to the accompanying drawings, of which:

Figure 1 is a perspective view of a reconfigurable frequency selective surface;

10      Figure 2 is a cross-section through the surface;

Figure 3 is a diagrammatic view of a part of the surface;

Figure 4 shows the frequency response of a frequency selective surface;

Figure 5 shows the variation of the frequency response as  
15      the surface is reconfigured;

Figure 6 shows a waveguide including a frequency selective surface;

Figure 7 shows a prototype waveguide, used for testing its transmission response;

20      Figures 8 and 9 show the transmission response of the prototype waveguide, and

Figures 9 and 10 show two forms of horn antenna employing frequency selective surfaces.

As shown in figure 6, the waveguide 4 has a rectangular cross-section and includes upper and lower walls 7,  
25

8 and two side walls 6. Two frequency selective surfaces 5 are mounted parallel to its two side walls 6. The frequency selective surfaces 5 divide the waveguide longitudinally into two portions, an inner portion being defined by the upper and lower walls 7, 8 and the frequency selective surfaces 5, and an outer portion being defined by the upper and lower walls 7, 8 and the side walls 6.

The frequency selective surfaces 5 are arranged to transmit at low frequencies and to reflect at higher frequencies. The surfaces 5 are then invisible to the electromagnetic waves in the lower frequency band, and the effective internal dimensions of the waveguide 4 are defined by the side walls 6 and the upper and lower walls 7, 8 of the waveguide 4. At higher frequencies, the frequency selective surfaces 5 will reflect the electromagnetic waves, and the effective internal dimensions of the waveguide 4 will then be defined by the frequency selective surfaces 5 and the upper and lower walls 7, 8 of the waveguide. The effective dimensions of the waveguide are therefore different for different frequencies of transmitted electromagnetic wave, so increasing the operating frequency range of the waveguide.

The operating frequency range of the waveguide is defined at its lower end by the cut-off frequency in the outer waveguide of the dominant  $TE_{10}$  propagation mode, and at its upper end by the upper limit of the band-stop

range (i.e. the reflection band) of the frequency selective surface.

Since electromagnetic waves at the upper end of the operating frequency range are reflected by the frequency selective surfaces and confined within the inner waveguide, the higher order modes of the outer waveguide are effectively suppressed. The waveguide therefore permits monomode propagation at the  $TE_{10}$  mode over a wide frequency range.

10 If the reflection coefficient of the frequency selective surfaces is -1 (the ideal value), the group and phase velocities of the high frequency signal in the inner waveguide and the low frequency signal in the outer waveguide will be the same. In practice, although this is approximately true at the centre of the range of operating frequencies, the phase and amplitude of the signals will deviate at other frequencies. This causes the apparent positions of the frequency selective surfaces to vary with frequency. By providing double- or 15 multi-layer frequency selective surfaces, the apparent positions of the frequency selective surfaces may be made to move inwards with increasing frequency, thereby providing a non-dispersive waveguide of even greater bandwidth.

25 By using reconfigurable frequency selective surfaces, which are described below with reference to figures 1 to 5, the operating frequency of the waveguide may be controlled electronically. The frequency selec-



tive surfaces, which may be fixed or reconfigurable and either single or multilayer structures, can be used to provide a number of waveguide devices, such as filters, polarisers or phase shifters. The surfaces may be  
5 positioned at any location within a waveguide. The reconfigurable frequency selective surfaces may be electronically tuned, the speed of the tuning and the performance of each application being governed by the array design and the process of attaining the recon-  
10 figurable frequency selective surface effect.

Figs. 8 and 9 show the results of experimental tests on the waveguides, which demonstrate the principles of operation of the waveguide. The results were obtained using the prototype waveguide shown in Fig. 7, which  
15 consists of a standard X-band waveguide from which the narrow side walls have been removed. The waveguide comprises broad upper and lower conducting walls 9, 10 having on their inner faces several longitudinal slots 11 into which frequency selective surfaces can be inserted.

20 The transmission response of the prototype in the X band (8-12.4 GHz) is shown in Fig. 8. When operated without any inserts, the prototype exhibits a moderately lossy transmission band from the cut-off frequency up to about 16GHz. Placing radar-absorbing material (RAM)  
25 along the lengths of the open sides of the waveguide increases insertion loss dramatically in the X-band, showing that fringing fields exist outside the waveguide when operated in this mode. When frequency selective

surfaces are placed in the outer slots of the waveguide (giving it the same transverse cross-section as the X-band waveguide, improved transmission is provided over the 14 to 16 GHz range, which corresponds to the reflection band of the frequency selective surfaces. Introducing the RAM with the frequency selective surfaces in place produces little disturbance to this high frequency band whilst the lower frequencies are attenuated by more than 50 dB. The frequency selective surfaces therefore clearly contain waves in the higher frequency range. The nulls seen at about 14.5 and 16.6 GHz are believed to be due to higher order modes caused by the poor performance of the transitions at this frequency.

Fig. 9 shows the results of a similar set of measurements carried out with J-band (12.4-18 GHz) transitions attached to each end of the test prototype. The separation of the frequency selective surfaces was equal to the width dimension of a standard J-band waveguide. The guiding effect of the frequency selective surfaces is again displayed. The design of an integrated transition incorporating frequency selective surfaces enables tuneable broadband waveguide designs to be operated with a single co-axial feed at all frequencies. The null observed near to 13GHz is due to a filtering effect caused by the frequency selective surface elements and the varying positions of the electrical walls. A reconfigurable frequency selective surface would enable a band-stop or a band-pass filtering response to be tuned.

As shown in Fig. 9, similar results to those produced in the frequency selective surface/open wall case were produced when frequency selective surfaces were inserted into a standard X-band waveguide. The close proximity of the copper wall of the waveguide to the frequency selective surfaces does not significantly modify their guiding effect. The figure also shows the calculated reflection coefficient amplitude for a single layer large array of tripoles over the range 13 to 18 GHz. The array used in the waveguide was a single line of tripole elements. The reflection band of the large frequency selective surface is broadly similar to the enhanced transmission range measured in the test prototype. The frequency selective surface reflection coefficients were calculated using a Floquet mode analysis, assuming that the finite line array of tripoles behaves as an infinite rectangular lattice array with vertical periodicity equal to the waveguide height. The calculations also assumed a nominal incidence angle of 30° from normal (a reasonable approximation to the varying angles of incidence in the waveguide), to account for the oblique nature of the plane waves which may be used to describe the fields in the waveguide for the  $TE_{10}$  mode.

A broadband/multiband antenna, which operates according to the same principles as the waveguide described above, is shown in Figs. 10 and 11. Fig. 10 shows a broadband pyramidal horn antenna having an outer

horn 12 of conducting material and an inner horn 13, formed of fixed or reconfigurable frequency selective surfaces. The frequency selective surfaces are invisible to electromagnetic signals of low frequency, which  
5 therefore occupy the outer horn, whereas signals of higher frequency are confined within the inner horn. The effective dimensions of the antenna therefore vary with the operating frequency, allowing it to operate over a wide frequency range.

10 Fig. 11 shows an alternative antenna comprising two co-axial cones 14, 15, both consisting of fixed or reconfigurable frequency selective surfaces. The antenna can be tuned to a specific frequency band for improved performance and for matching to a waveguide of the type  
15 described above. The walls of the outer cone 14 could be replaced by conducting walls if band tuning and/or antenna matching is not required. If desired, the antenna may include more than two cones.

As shown in figure 1, a reconfigurable frequency  
20 selective surface consists of two parallel arrays 1, 2 of elements 3. The array elements 3 may be either electrically conductive elements, such as dipoles, printed on a dielectric substrate, or apertures, such as slots, formed in a conductive surface (Babinet's compliment of the  
25 former). A non-reconfigurable frequency selective surface consists simply of just one of the arrays 1, 2 shown in figure 1.

The two arrays 1,2 are arranged in close proximity

with one another, so that the elements 3 of the first array 1 are closely coupled with the elements of the second array 2. The separation  $S$  of the arrays is as small as possible, whilst ensuring that the elements of the first array 1 are electrically insulated from the elements of the second array 2, and will generally be of the order of 0.03 wavelengths or less, although this will depend on the particular array design, and the dielectric constant of the substrate.

10 The second array 2 is displaceable relative to the first array 1 by a small distance  $DS$ . In the embodiment shown in figure 1, the second array 2 can be displaced transversely, parallel to the surfaces of the arrays, in the direction of the  $Y$ -axis. Other types of displacement are, however, possible: for example, the second array 2 could be displaced in the direction of the  $X$ -axis or the  $Z$ -axis (thereby altering the distance  $S$  separating the two arrays) or it could be rotated about the  $Z$ -axis, or displaced in any combination of those directions.

20 When the arrays 1,2 are aligned accurately with one another (so that  $DS=0$ ), the elements 3 of the first array 1 lie directly over the elements of the second array 2, thereby shadowing the second array 2 from the incident electromagnetic waves. The frequency response of the surface is then similar to that of a single array which, as shown in figure 4, includes a narrow reflection band and upper and lower transmission bands. The letters  $f_R$  denote the reflection band centre frequency, which

corresponds to the resonant frequency of the surface, and the letters  $f_T$  denote the frequency of the lower transmission band. The frequencies  $f_R$  and  $f_T$  of the reflection and transmission bands are determined by the length of the antenna elements 3 and the size of the array.

As shown in figures 2 and 3, the first array 1 has a plurality of elements 3 of length  $L_1$ , and the second array 2 has a plurality of elements of length  $L_2$ . The separation  $D_1, D_2$  and the arrangement of the elements in each of the arrays is similar, so that when  $DS=0$  the elements of the second array 2 lie in the shadows of the elements of the first array 1.

When, as shown in figure 2, the second array 2 is displaced transversely in the direction  $Y$  by a distance  $DS$ , the ends of the elements 3 of the second array 2 then extend by a small distance  $DL$  beyond the ends of the elements of the first array 1. Since the elements of the two arrays are closely coupled, this produces an increase in the overall effective length of each element, which affects the frequency response of the surface. As shown in figure 5, the reflection frequency  $f_R$  of the surface is shifted by an amount that is approximately proportional to the displacement  $DS$ . The frequency response of the surface can similarly be translated by displacing the second array 2 in the  $X$  or  $Z$  directions, by rotating it about the  $Z$ -axis, or by any combination of those movements.

An example of the results that can be achieved with a particular reconfigurable frequency selective surface will now be described. The particular frequency selective surface consists of two arrays 1,2 of linear  
5 dipoles 3, printed in a square lattice on a 0.037mm thick dielectric substrate of dielectric constant 3. The geometry of the lattice unit cell is shown in figure 3, wherein L represents the length of the antenna element, W the element's width, and D the side length of the unit  
10 cell (equal to the separation of adjacent antenna elements). In the first array 1,  $L=4.3\text{mm}$ ,  $W=0.4\text{mm}$  and  $D=6\text{mm}$ . In the second array 2,  $L=3.25\text{mm}$ ,  $W=0.4\text{mm}$  and  $D=6\text{mm}$ . Each array is square, having sides of length 20cm, and the separation S between the arrays is about  
15 0.225mm.

The measured and theoretical response of the surface to microwaves of frequency 12-40GHz at both normal incidence and a TE incidence of  $45^\circ$ , with the electric field parallel to the dipoles, is shown in figure 5. By  
20 comparison, the variation in the frequency response of a single array with increasing dipole length is shown as a solid line at the top of the graph.

When the two arrays are substantially aligned, with DS in the range 0 to 0.625mm, the frequency response of  
25 the surface is similar to that of a single array having the dimensions and lattice arrangement of the first array 1. Resonance takes place at frequencies of about 31GHz and 27GHz for normal and TE: $45^\circ$  states of incidence

respectively. A frequency shift takes place as the transverse displacement DS of the second array 2 is increased, maximum measured frequency shifts of 36% and 22% for normal and TE:45° states of incidence respectively being achieved at a displacement of DS=3mm. At that displacement, the elements 3 of the second array 2 completely fill the gaps between the elements of the first array 1, and so a further increase in the displacement DS has no further effect on the frequency response of the surface.

Reducing the separation S of the arrays, thereby increasing the coupling between the elements, allows greater frequency shifts to be achieved. For example, with a separation of 0.025mm, frequency shifts of up to 60% can theoretically be obtained. The theoretical frequency shift at a separation S of 0.025mm is also shown in figure 5. There is no deterioration in the band widths or band spacing ratio ( $f_R/f_T$ ) of the surface as the displacement increases and the response of the surface is therefore stable throughout the frequency range.

Various modifications of the apparatus described above are, of course, possible. Many different array geometries could be used and each array may consist either of a plurality of conductors on a dielectric substrate, or a perforated plate, or a combination of both. The antenna elements may be dipoles, cross-dipoles, tripoles, Jerusalem crosses, squares, open-ended



loops or any other type of antenna element. The elements need not necessarily be arranged periodically and the arrays may be planar or curved. The frequency selective surface may further consist of two or more closely-  
5 coupled arrays of elements, and the respective arrays may either be displaced in a direction parallel to the surfaces of the arrays, or rotated or their separation altered, or the medium separating the arrays may be  
adjusted (for example, by adjusting its dielectric  
10 constant).

The relative displacement of the two arrays may be controlled in various different ways. For example, piezoelectric actuators can be used to control the precise relative movement of the arrays, and the arrays  
15 can be printed directly onto the piezoelectric material. The frequency selective surface may have piezoelectric actuators positioned at some sub-areas of its surface, i.e. not everywhere on its surface. Alternatively, the arrays can be mounted at a small separation and air  
20 pumped from the gap between the arrays to alter their separation.

## Claims:

1. A waveguide including a frequency selective surface, the frequency selective surface being arranged to influence the frequency response of the waveguide.
- 5 2. A waveguide according to claim 1, in which at least one frequency selective surface is mounted within the waveguide to divide the waveguide longitudinally into two or more parts.
3. A waveguide according to claim 2, in which the  
10 frequency selective surface is parallel to a wall of the waveguide.
4. A waveguide according to claim 3, in which two frequency selective surfaces are mounted within the waveguide, parallel to the side walls thereof.
- 15 5. A waveguide according to any one of the preceding claims, in which the frequency selective surface is a reconfigurable frequency selective surface.
6. A waveguide according to claim 5, in which the reconfigurable frequency selective surface comprises at  
20 least two arrays of elements, the arrays being arranged in close proximity with one another so that elements of a first array are closely coupled with elements of a second array adjacent to the first array, the first array being

displaceable with respect to the second array to adjust the frequency response of the surface.

7. An antenna for microwave radiation, comprising a outer horn and an inner horn, wherein the inner horn  
5 includes a frequency selective surface.
8. An antenna according to claim 7, in which the outer horn includes a frequency selective surface.
9. An antenna according to claim 7 or claim 8, in which the inner and outer horns are coaxial.
- 10 10. An antenna according to any one of claims 7 to 9, in which the horns have a rectangular transverse cross-section.
11. An antenna according to any one of claims 7 to 9, in which the horns have a circular transverse cross-  
15 section.
12. An antenna according to any one of claims 7 to 11, in which at least one frequency selective surface is a reconfigurable frequency selective surface.
13. A waveguide according to claim 1, in which a  
20 frequency selective surface is provided over an open end of the waveguide.

1/9

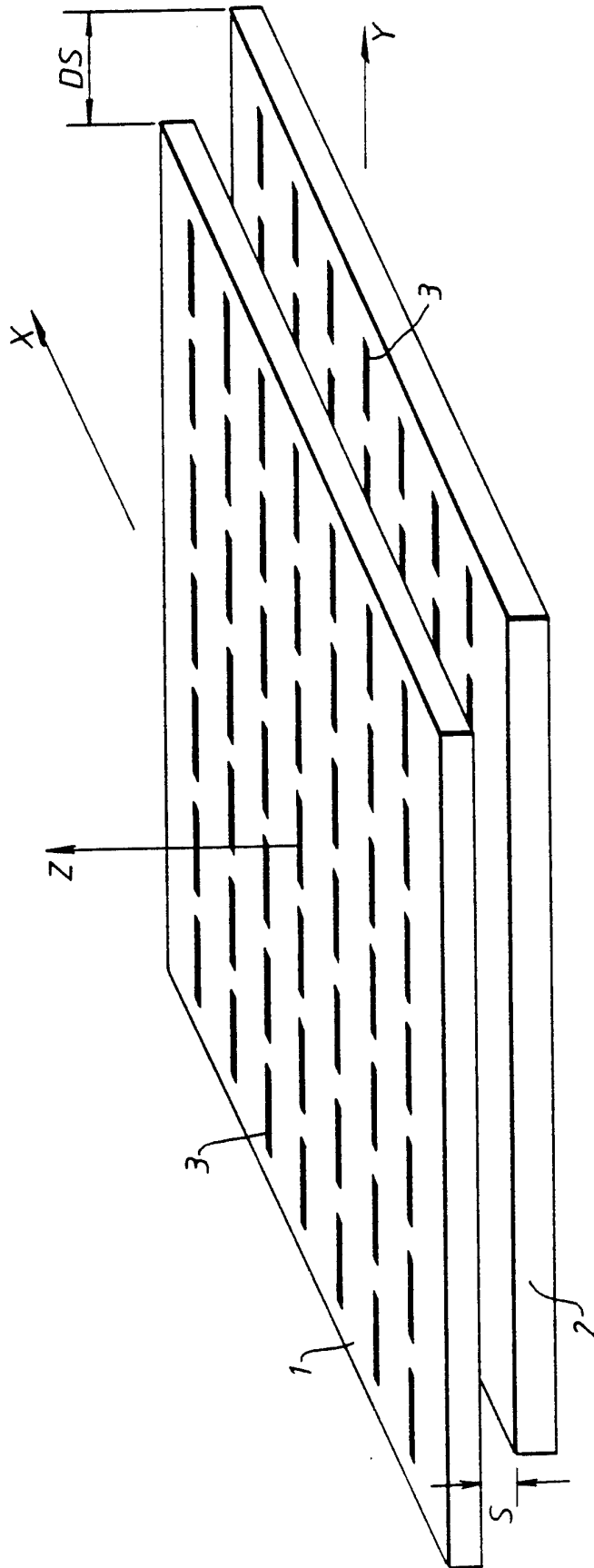

Fig. 1.

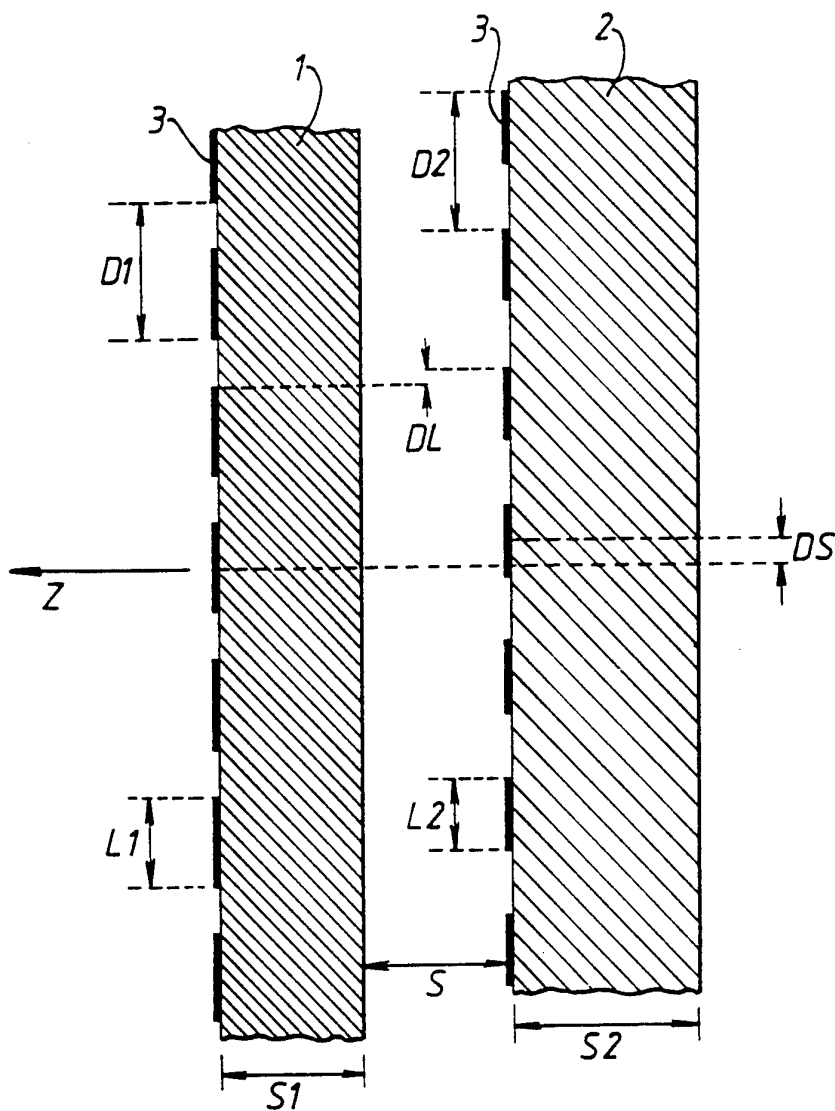

Fig.2.

3/9

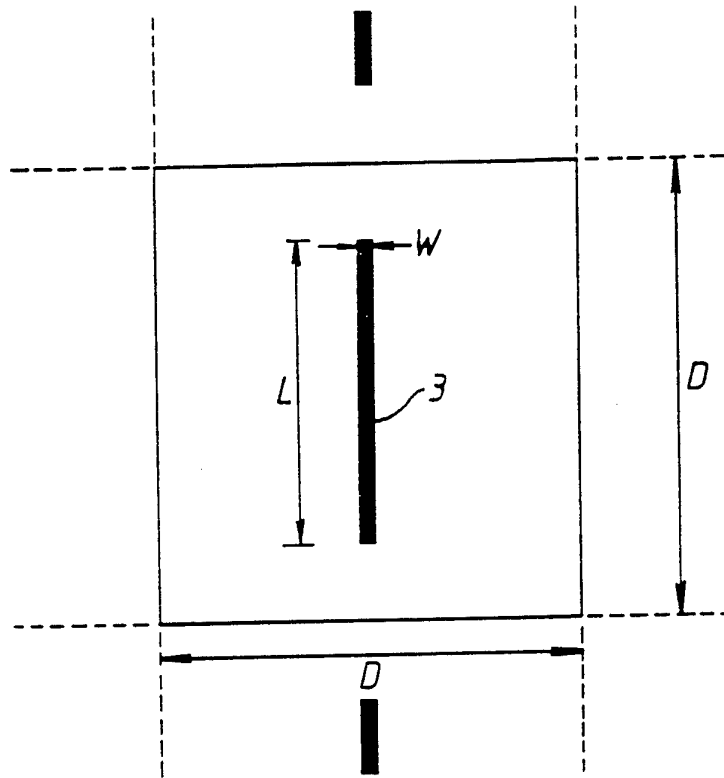

Fig. 3.

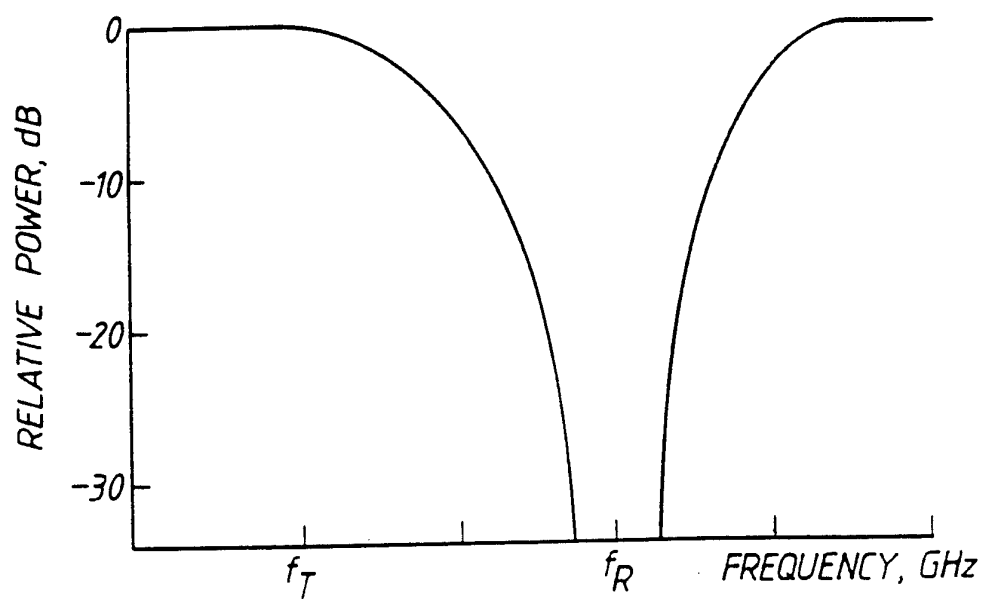

Fig. 4.

4/9

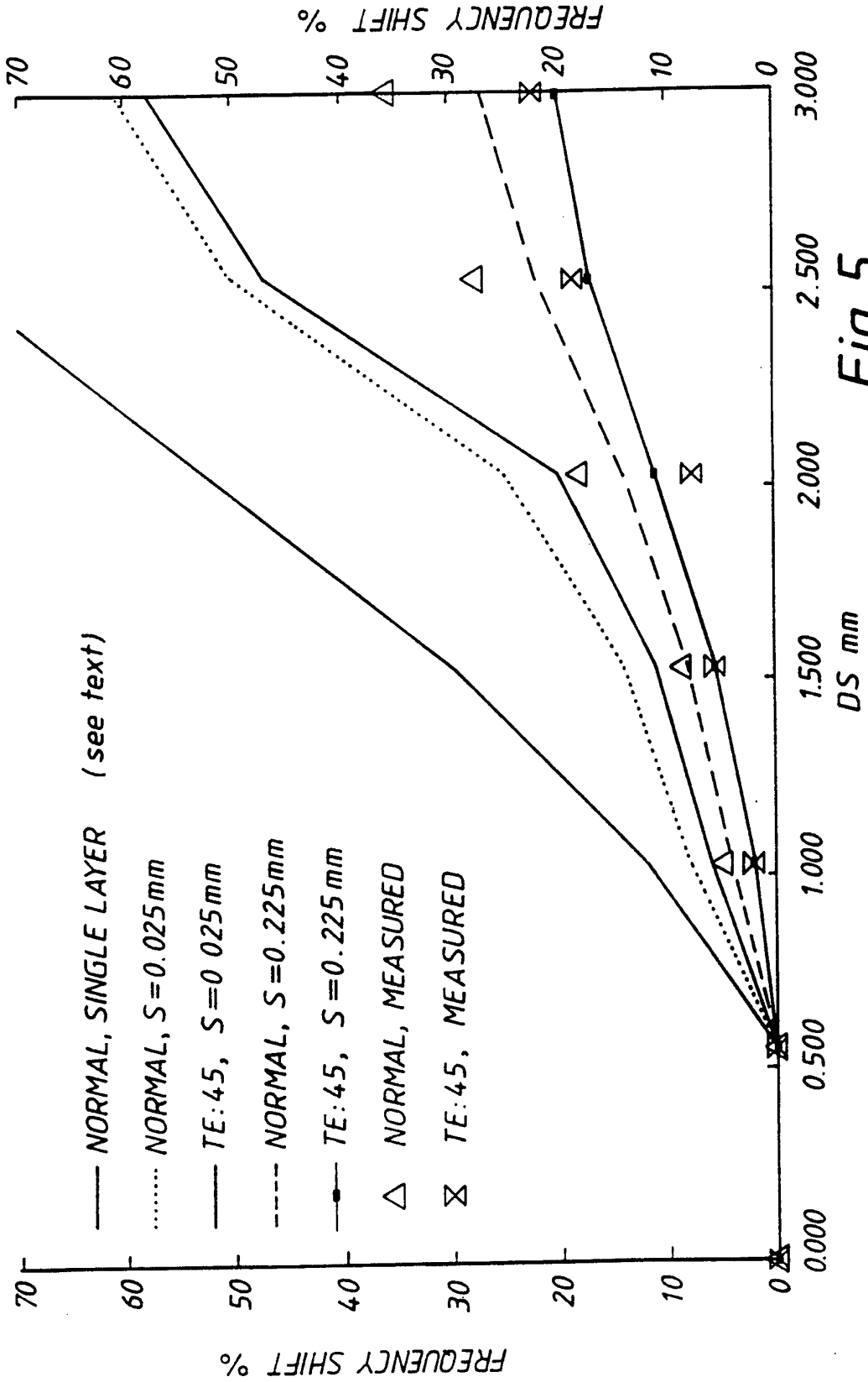

Fig. 5.

5/9

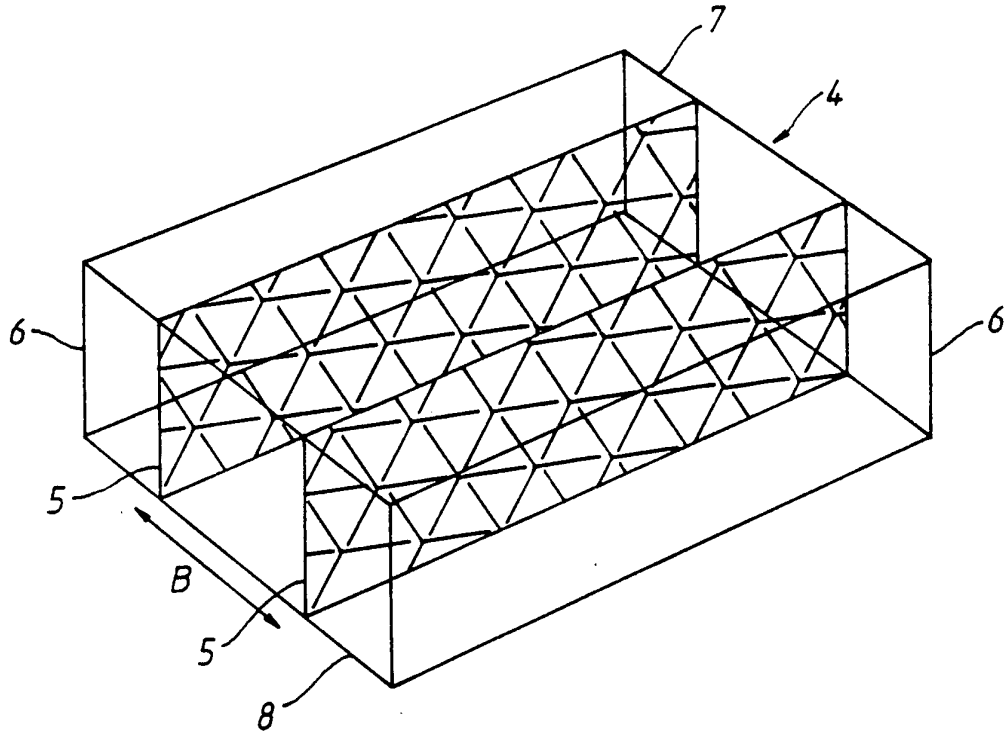

Fig.6.

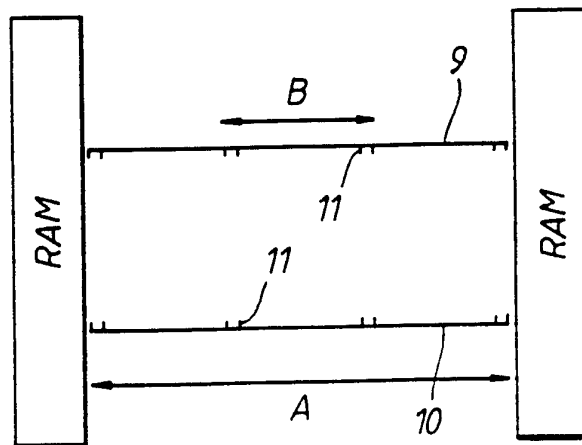

Fig.7.



6/9

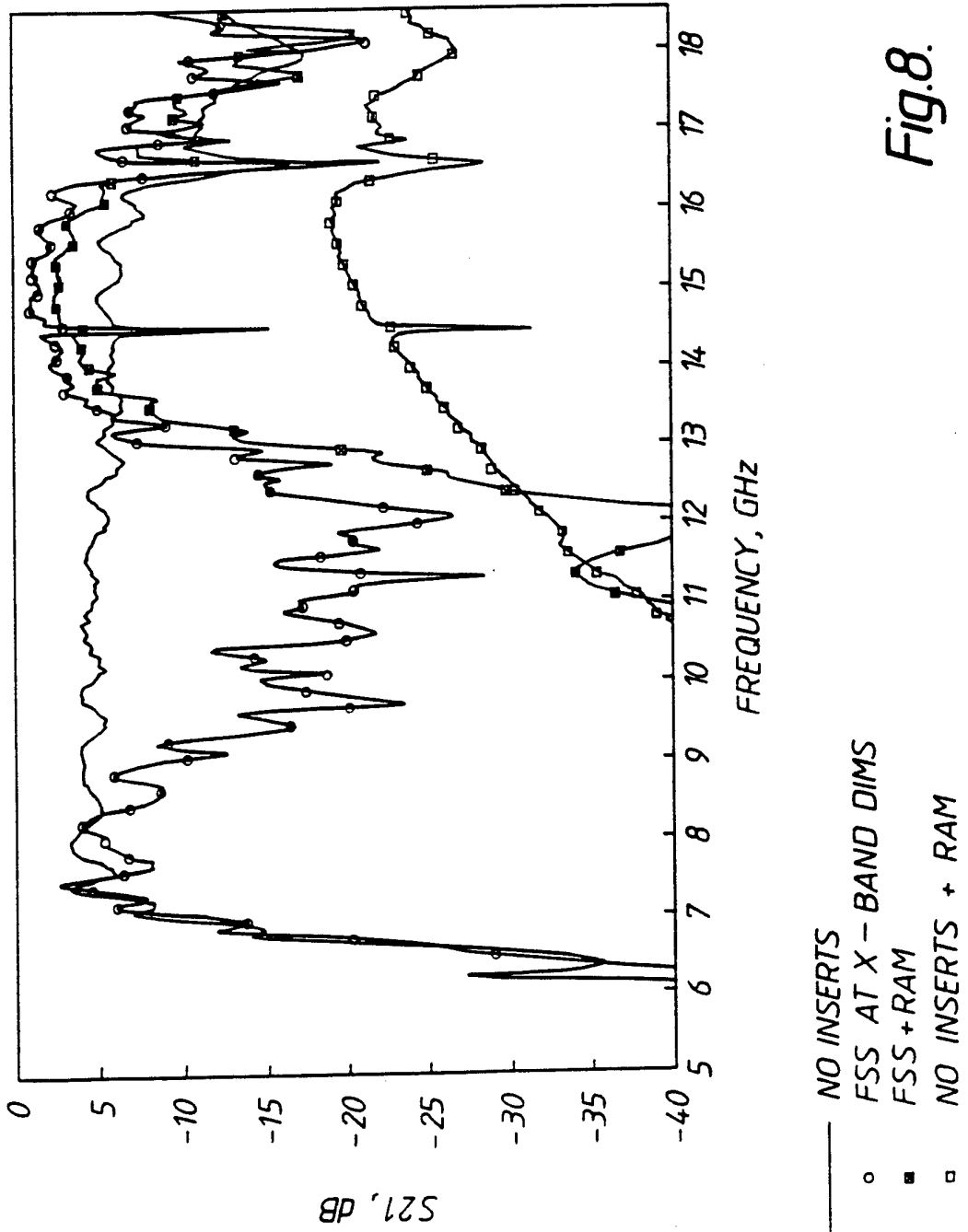

Fig.8.

7/9

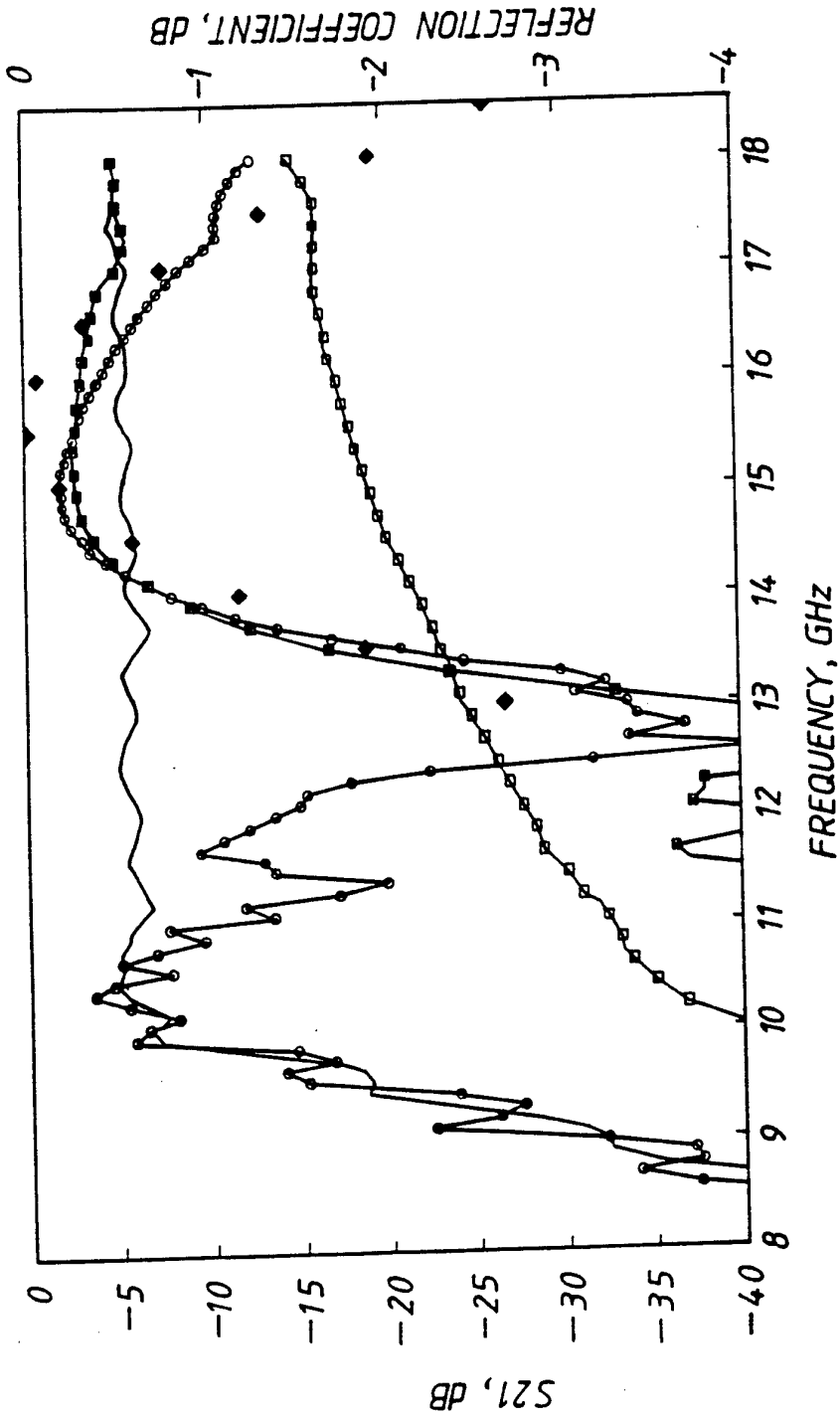

Fig. 9.

8/9

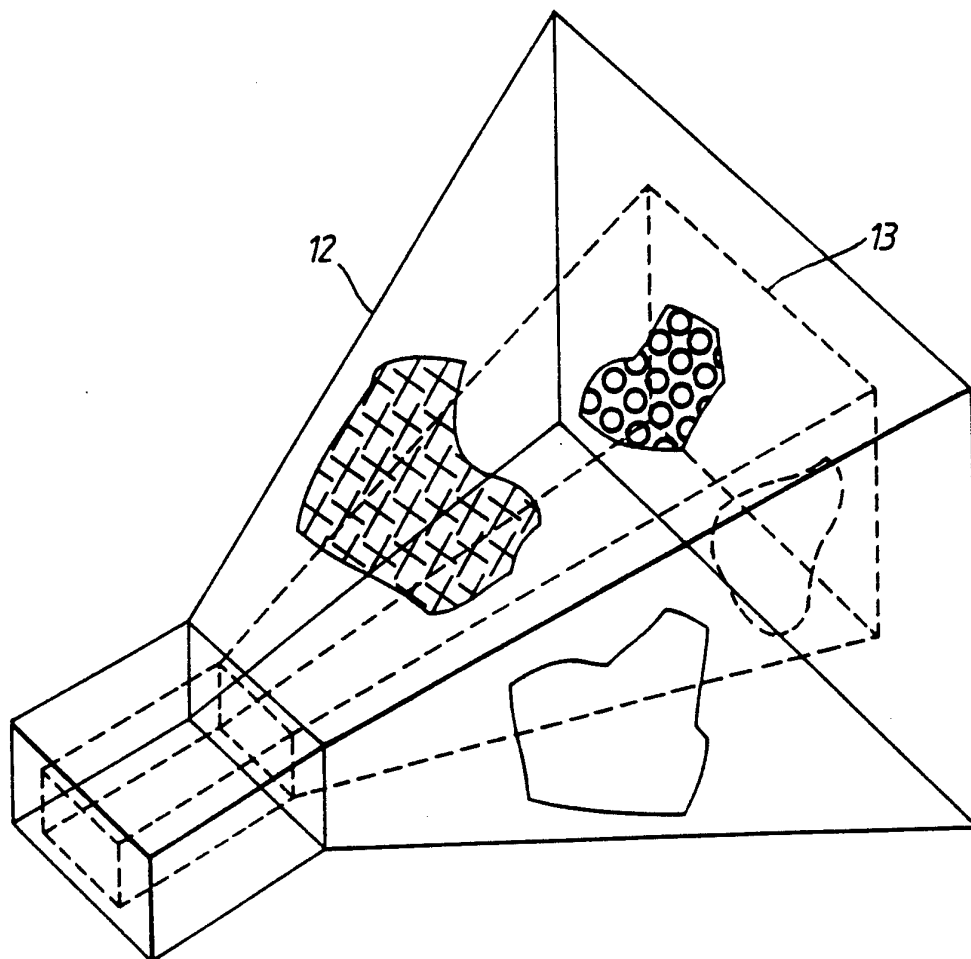

Fig.10.

9/9

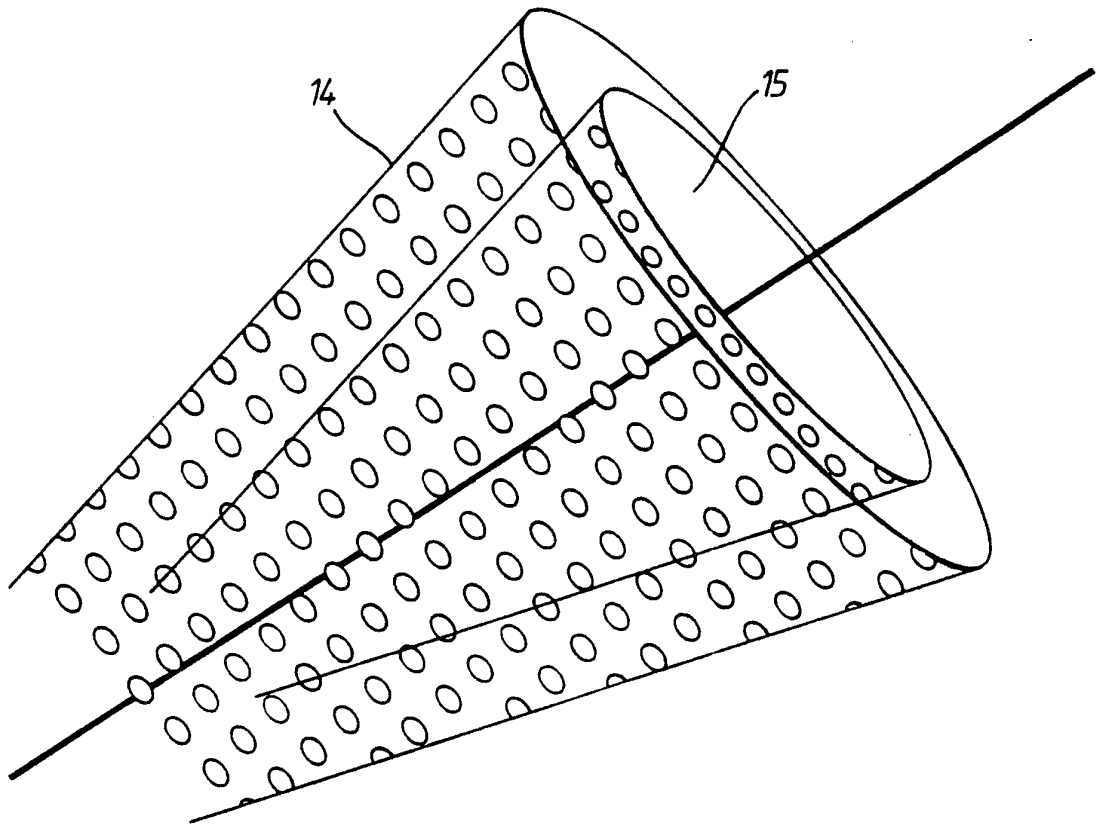

Fig.11.

INTERNATIONAL SEARCH REPORT

PCT/GB 92/01173

International Application No

<b>I. CLASSIFICATION OF SUBJECT MATTER</b> (if several classification symbols apply, indicate all) <sup>6</sup>		
According to International Patent Classification (IPC) or to both National Classification and IPC		
Int.Cl. 5 H01Q15/00; H01Q13/02; H01P3/12		
<b>II. FIELDS SEARCHED</b>		
Minimum Documentation Searched <sup>7</sup>		
Classification System	Classification Symbols	
Int.Cl. 5	H01Q ; H01P	
Documentation Searched other than Minimum Documentation to the Extent that such Documents are Included in the Fields Searched <sup>8</sup>		
<b>III. DOCUMENTS CONSIDERED TO BE RELEVANT<sup>9</sup></b>		
Category <sup>o</sup>	Citation of Document, <sup>11</sup> with indication, where appropriate, of the relevant passages <sup>12</sup>	Relevant to Claim No. <sup>13</sup>
X	US,A,3 633 206 (MCMILLAN) 4 January 1972 see column 3, line 1 - line 46 see column 10, line 8 - line 54; figures 1,3A,B ---	1, 13
X	PATENT ABSTRACTS OF JAPAN vol. 014, no. 584 (E-1018)27 December 1990 & JP,A,22 54 801 ( MIYATA YOSHIHIDE ) see abstract ---	7
A	US,A,4 028 650 (KONISHI ET AL.) 7 June 1977 see claims 1-5; figures 1-17 ---	1-6
	-/--	
<p><sup>o</sup> Special categories of cited documents :<sup>10</sup></p> <p>"A" document defining the general state of the art which is not considered to be of particular relevance</p> <p>"E" earlier document but published on or after the international filing date</p> <p>"L" document which may throw doubts on priority claim(s) or which is cited to establish the publication date of another citation or other special reason (as specified)</p> <p>"O" document referring to an oral disclosure, use, exhibition or other means</p> <p>"P" document published prior to the international filing date but later than the priority date claimed</p> <p>"T" later document published after the international filing date or priority date and not in conflict with the application but cited to understand the principle or theory underlying the invention</p> <p>"X" document of particular relevance; the claimed invention cannot be considered novel or cannot be considered to involve an inventive step</p> <p>"Y" document of particular relevance; the claimed invention cannot be considered to involve an inventive step when the document is combined with one or more other such documents, such combination being obvious to a person skilled in the art.</p> <p>"&amp;" document member of the same patent family</p>		
<b>IV. CERTIFICATION</b>		
Date of the Actual Completion of the International Search	Date of Mailing of this International Search Report	
26 FEBRUARY 1993	05.03.93	
International Searching Authority	Signature of Authorized Officer	
EUROPEAN PATENT OFFICE	ANGRABEIT F.F.K.	

III. DOCUMENTS CONSIDERED TO BE RELEVANT (CONTINUED FROM THE SECOND SHEET)		
Category °	Citation of Document, with indication, where appropriate, of the relevant passages	Relevant to Claim No.
A	GB,A,600 433 (BOOKER) 8 April 1948 see page 1, left column, line 21 - right column, line 87; figures 1-6 ---	7-13
A	US,A,3 028 565 (WALKER ET AL.) 3 April 1962 see claims 1,2; figure 2 ---	1-4
A	EP,A,0 468 623 (BRITISH AEROSPACE) 29 January 1992 see abstract see column 4, line 19 - line 39 see column 5, line 4 - line 18; figures 1,2 ---	1,5,7,12
E	GB,A,2 253 519 (LOUGHBOROUGH UNIVERSITY OF TECHNOLOGIE) 9 September 1992 see the whole document -----	1-13

**ANNEX TO THE INTERNATIONAL SEARCH REPORT  
ON INTERNATIONAL PATENT APPLICATION NO.**

GB 9201173  
SA 61615

This annex lists the patent family members relating to the patent documents cited in the above-mentioned international search report.  
The members are as contained in the European Patent Office EDP file on  
The European Patent Office is in no way liable for these particulars which are merely given for the purpose of information. 26/02/93

Patent document cited in search report	Publication date	Patent family member(s)	Publication date
US-A-3633206	04-01-72	None	
US-A-4028650	07-06-77	JP-C- 1189354	13-02-84
		JP-A- 49010648	30-01-74
		JP-B- 58003401	21-01-83
		AU-A- 5597073	28-11-74
		CA-A- 977049	28-10-75
		DE-A, B 2326331	29-11-73
		FR-A, B 2185866	04-01-74
		GB-A- 1438149	03-06-76
		NL-A- 7307150	27-11-73
		US-A- 3914713	21-10-75
GB-A-600433		None	
US-A-3028565		None	
EP-A-0468623	29-01-92	None	
GB-A-2253519	09-09-92	None	