

June 2, 1953

F. L. MORROW

2,640,255

SEPARATING END FITTING FOR SLIDE FASTENERS

Filed Aug. 15, 1946

Fig. 1.

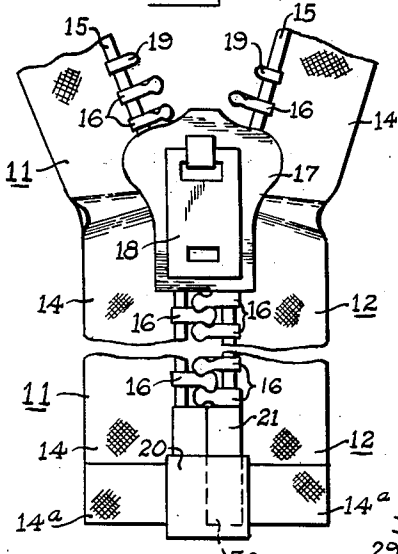

Fig. 2.

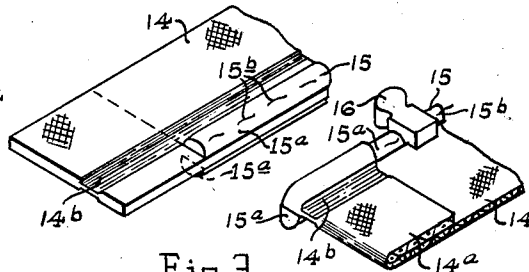

Fig. 3.

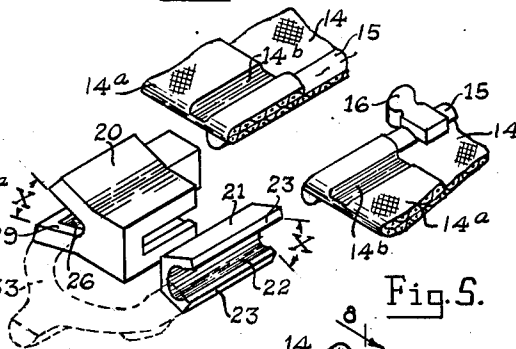

Fig. 4.

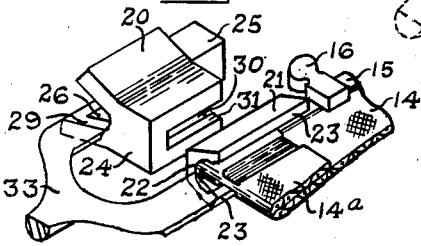

Fig. 5.

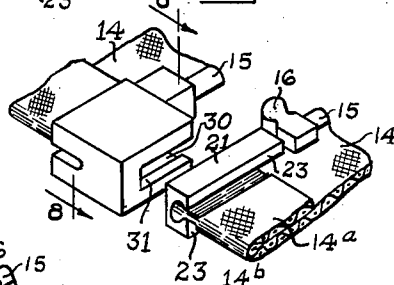

Fig. 7.

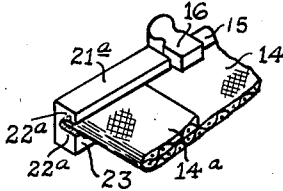

Fig. 8.

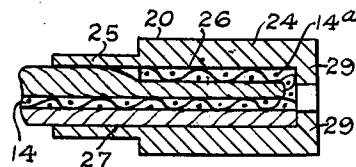

Fig. 6.

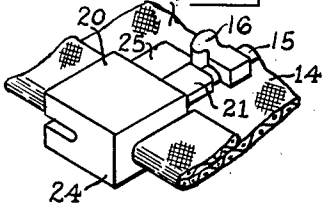

Fig. 9.

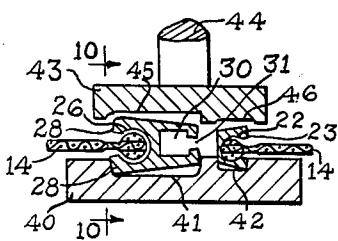
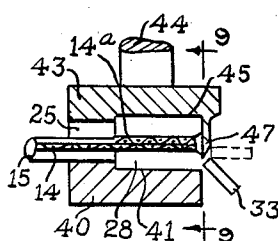

Fig. 10.



INVENTOR.  
Frederick L. Morrow  
BY  
*[Signature]*  
ATTORNEY

# UNITED STATES PATENT OFFICE

2,640,255

## SEPARATING END FITTING FOR SLIDE FASTENERS

Frederick L. Morrow, New Britain, Conn., assignor  
to The North & Judd Manufacturing Company,  
New Britain, Conn., a corporation of Connecticut

Application August 15, 1946, Serial No. 690,651

2 Claims. (Cl. 29—148)

1

This invention relates to slide fasteners and, in particular, to the provision of new and improved separating end fittings therefor and to the provision of new and improved methods of forming and assembling or attaching such end fittings to the stringer tapes of slide fasteners.

It is an object of this invention to provide such an end fitting which, though of die cast construction, is formed separate from and independently of slide fastener stringer tapes, whereby to avoid damage to the aforesaid stringer tapes, such as charring or tendering, by reason of necessarily high and destructive die casting temperatures, and cooperative parts of which end fitting are simultaneously attached directly to their supporting stringer tapes by clamping, clinching or crimping.

It is a further object of this invention to provide new and improved methods of forming and/or attaching such end fittings to the stringer tapes of slide fasteners.

It is a further object of this invention to provide, as an intermediate product, a separating end fitting blank or assembly comprising complementary pin and retainer members connected by an integral gate or sprue which retains the aforesaid pin and retainer members in predetermined spaced alignment for ease and convenience of attachment simultaneously to their respective supporting stringer tape end portions.

It is a further object of this invention to provide such a unitary assembly or blank wherein the aforesaid pin and retainer members are provided with tape engaging jaws which, as cast, are spread only sufficiently to accommodate or facilitate the threading of the lower stringer tape end portions therein to a predetermined position wherein the subsequent bending of the cast metal of the pin and retainer members, during clinching, is maintained at a minimum.

It is a further object of this invention to provide such a blank or assembly wherein means is provided in at least one of the members for limiting or defining the relative positions of the aforesaid member and its supporting tape.

It is a further object of this invention to provide such a blank or assembly wherein the aforesaid function is performed by the severable gate or sprue before its severance from the assembly.

It is a further object of this invention to provide such a method wherein, subsequent to proper placement of the stringer tape ends with respect to the blank, the pin and retainer members are simultaneously clinched on their respective stringer tapes with concurrent severance of the

2

gate or sprue from the pin and retainer members.

These and other objects and advantages of my invention will clearly appear from the following description, taken with the accompanying drawing forming a part thereof, and will be pointed out in the appended claims.

In the drawing:

Fig. 1 is a diagrammatic plan view of one form of slide fastener equipped with a separating end fitting constructed according to the principles of this invention;

Fig. 2 is a fragmentary diagrammatic isometric view illustrating the preparation of the stringer tape end portions of a slide fastener for attachment of a separating end fitting as shown in Fig. 1;

Fig. 3 is a view generally similar to Fig. 2 but showing also a unitary casting comprising pin and retainer forming members connected by a severable gate or sprue, the gate or sprue being shown in dash lines in the interest of clear disclosure;

Fig. 4 is a view similar to Fig. 3 but showing the prepared tape end portions in position in the pin and retainer forming members before they are clinched thereto and prior to removal of the gate or sprue therefrom;

Fig. 5 is a view similar to Fig. 4 but showing the pin and retainer forming members clinched to the prepared stringer tape end portions and the gate or sprue severed therefrom;

Fig. 6 is a view similar to Fig. 5 but showing the pin and retainer members operatively assembled or connected, to couple the stringer tape ends;

Fig. 7 is a fragmentary isometric view illustrating a modified form of pin member formed according to this invention;

Fig. 8 is an enlarged longitudinal section taken substantially along the plane indicated by the lines 8—8 in Fig. 5;

Fig. 9 is a transverse section illustrating the clinching of the pin and retainer forming members simultaneously; and

Fig. 10 is a longitudinal section illustrating the severance of the gate from the pin and retainer forming members simultaneously with the clinching thereof as shown in Fig. 9.

Heretofore, in order to secure the low cost provided by die casting of slide fastener separating end fittings, comprising parts which are relatively complicated and intricate, the pin and retainer portions or members thereof have been cast separately, directly upon the slide fastener

stringer tapes with resultant burning, charring or "tendering" (i. e. incipient charring) of the stringer tapes engaged by, and adjacent to, the hot molten metal applied to the tapes. While some attempts have been made to cast the members independently of the stringer tapes, the jaws of the members as cast have been sufficiently greatly spread to permit of their passage (before clinching) sidewise over the reinforced stringer tape edges, and, in many cases, over platelike metallic reinforcements previously applied to the underlying tape areas or portions. Such spreading requires such degree of bending in the soft and relatively brittle metal of the fitting parts, during subsequent clinching, as frequently to crack or strain this metal internally of the parts. Furthermore, these parts were aligned and attached, by separate operations, independently to their respective supporting stringer tapes.

According to this invention, the pin and retainer members of each separating end fitting are cast integrally with a connecting gate or sprue which fixes their relative positions until its severance. The lower prepared ends of both stringer tapes of a slide fastener are predeterminedly positioned each in one of the jaws provided in the pin and retainer members, the jaws are simultaneously clinched and the gate or sprue removed concurrently.

The accompanying drawing is illustrative only, and diagrammatic; all fillets, bevels and other superficial refinements and complications have been eliminated in the interest of clear disclosure.

The illustrative slide fastener shown in Fig. 1 comprises complementary righthand stringer 11 and lefthand stringer 12. These stringers 11 and 12 are similar and each comprises a flexible textile or other tape 14 with a reinforced edge portion 15 to which is secured a row of predeterminedly spaced "scoops" or interlocking members 16.

A conventional slider 17, provided with a conventional upwardly diverging internal scoop engaging and guiding channel (not shown), is supported on the scoops 16 for conventional sliding movement, upwardly thereof to close the fastener by progressively engaging the rows of scoops, and downwardly thereof to open the fastener by progressively disengaging or uncoupling the rows of scoops 16. A manually engageable pull tab 18 is connected to the slider 17 to facilitate operation of the slider for the above described purpose.

Movement of the slider 17 upwardly to close the fastener is limited by a pair of top stops 19 each secured to the reinforced edge portion 15 of one of the above described stringer tapes adjacent the uppermost scoop 16 thereon.

At their lower ends the stringer tapes are detachably connected by a separating end fitting formed and attached according to this invention. This fitting comprises generally a retainer member 20 secured to the lower end of the lefthand stringer 11 and a complementary detachably engageable pin member 21 secured to the lower end of the righthand stringer 12, as hereinafter described.

The pin member 21, when clinched to the stringer 12 is in the form of an elongated, slotted block, preferably of rectangular cross section (see Fig. 5). Before attachment it is cast with a coextensive central channel 22 communicating with one (the right) side through a spread slot forming opposed spread jaws 23.

The illustrated retainer member, when clinched to the stringer 11, is in the form of a pair of integral block like portions 24 and 25, the upper portion being of cross-section similar to that of the pin member 21. The lower portion 24 has a channel portion 26 extending downwardly just short of the lower end (Figs. 8 and 9) and joining or continuing the similar channel portion 27 in the portion 25 for accommodating the reinforced edge portion 15 of the righthand stringer 11. This channel 26, 27 communicates with the righthand side of the member 20 by means of a spread slot (as cast) forming spread jaws 28, 29 (Fig. 9).

Termination of the channel 26, 27 short of the lower end of the member 20 forms a pair of opposed end walls or shoulders 29, 29 which define the position of the stringer tape when it is threaded downwardly into the channel 26 as shown in Fig. 8.

The member 20 extends leftwardly of the portion 27 thereof to provide a socket or chamber 30 for detachably receiving the lower portion of the pin member 21. This socket or chamber is formed by a recess or channel terminating short of the bottom of the portion 24 and a communicating slot 31 leading to the left side of the portion 24 (see Fig. 9). This slot 31 is cast to final width and it accommodates the portion of the tape 14 adjacent the pin member 21 when it is inserted in the socket 30 as shown in Fig. 6.

If desired, when casting the pin member, the channel 22 may be terminated short of the lower end thereof to form tape aligning walls, abutments or shoulders 22a similar to the above described walls or shoulders 29 as shown in Fig. 7 wherein the modified pin member is designated 21a.

As hereinbefore stated, the pin and retainer forming members are cast integrally; as shown in Figs. 3 and 4. These members, as cast, are united by a sprue or gate 33 which is severed therefrom concurrently with clinching of the members 20 and 21 on their respective stringer tapes, as shown in Fig. 10. This sprue or gate 33 rigidly maintains the members 20 and 21 in predetermined fixed space relation until its severance as will be readily understood.

In order to minimize the thickness of tape clinched between jaws 23, 23 and jaws 28, 28 and the thickness thereof which must be accommodated by the slot 31 leading to the channel or recess 30, a portion of the tape 14 adjacent the reinforced edge portion 15 thereof is compressed as indicated at 14b prior to being overlapped upon itself (Fig. 2). If desired, it may be recompressed after being overlapped.

The reinforced edge portions 15 of the stringer tapes 14, as shown in Fig. 2 are formed by a pair of edge reinforcing cords 15a secured to opposite sides of the tape edge portion by stitching 15b. In order to facilitate doubling or overlapping of the tape end portions these cords 15a are cut away for a suitable distance from the bottom end of the tapes, as shown in Fig. 2.

Appropriate tapes areas may be treated with suitable adhesive and/or sizing or stiffening compositions, either before or after they are compressed at 14b.

As shown in Fig. 3, after preparation, the lower tape end portions are overlapped and compressed to form channels 14b of reduced thickness for accommodating the jaws 23, 23 of the pin member 21 (or 21a) and the jaws 28, 28 of the retainer member 20 whereby to reduce to a mini-

5

mum the necessary spreading of the intervening slots or the jaw surfaces when cast.

The angle between respective pairs of jaws is designated X in Fig. 3, and I have found that this angle may vary from a maximum of 30 degrees to a minimum of 20 degrees with provision of adequate space within the channels 22 and 26 to permit convenient and easy endwise threading of the prepared stringer tape ends (as shown in Fig. 3) into these channels to the desired and/or required extent.

As may be seen in Figs. 3 and 4, where the channel 22 is coextensive in length with the pin member 21, the upper end of the lefthand branch of the sprue or gate 33 provides a shoulder, stop or abutment (before its subsequent removal) to limit the position of the lower (doubled) lefthand stringer tape edge when it is threaded into the pin or tube member 21; the same function is accomplished, at the same time, with respect to the lower (doubled) edge of the righthand stringer tape by the end walls or shoulders 29 of the channel 26 (see Fig. 8).

In order to accomplish simultaneous clinching of the jaws of both members 20 and 21 and severance of the gate or sprue 33 therefrom, I may, preferably, utilize a simple clinching and cutting press such as that illustrated in Figs. 9 and 10.

As shown therein, this press may comprise a stationary platen 40 provided with recesses 41 and 42 accommodating respectively, the members 20 and 21 with gate 33 attached, and a movable platen 43 supported by a reciprocating rod 44. The platen 43 is provided with a recess 45 complementary with the above described recess 41 and a recess 46 complementary with the above described recess 42 as well as a cutting blade or knife 47 (Fig. 10) extending completely across the platen 43, transversely, for engaging and cutting both branches of the gate 33, on a downward stroke of platen 43 simultaneously with clinching of the jaws of members 20 and 21.

In the illustrated blanks 20, 21, 33, the jaws of the members 20 and 21 extend oppositely and outwardly of each blank or assembly formed by a pin member 21, retainer member 20 and integral gate or sprue 33. The jaws 23, 23 and 28, 28 of the members 20 and 21, as cast, are spread equally and sufficiently only to permit the free threading of the prepared stringer tape bottom end portions therein as stated above; thus bending, and damage incident to bending, during clinching, is maintained at a minimum.

Substantial time and labor is saved by the above described arrangement of the parts of the blank or assembly 20, 21, 33 which facilitates threading of both tape end portions of a fastener simultaneously downwardly into final position in the minimally spread jaws (23, 23 and 28, 28) which are thereafter simultaneously clinched to the tape portions aligned therewith concurrently with severance of the gate or sprue 33 from the pin and retainer member, as illustrated in Figs. 9 and 10.

Preferably, in assembling such a blank to a conventional slide fastener such as that illustrated in Fig. 1, the fastener is "pulled up" by coupling the rows of scoops 16 thereon by movement of the slider 17 at least partway upwardly from the lower ends of the rows of scoops 16. Thereafter prepared lower ends of the stringer tapes 14 may be folded in alignment as shown in Fig. 3, and the lower ends of the tapes 14 separated sufficiently for alignment of the prepared

6

lower edge portions with the channels of the pin and retainer members (which are of equal length) into which channels they are threaded downwardly until such movement, downwardly of the respective pin and retainer members, is limited by the shoulders or abutments 29 of the retainer 20 (Fig. 8), the upper end of the branch of the gate 33 coinciding with the channel 22 of the pin member 21 (Figs. 3 and 4), or the shoulders or abutments 22a (Fig. 7) of the pin member 21a.

Thereafter, by a single operation (Figs. 9 and 10), the jaws 23, 23 and the jaws 28, 28 are clinched while both branches of the gate or sprue 33 are clipped or severed from the pin and retainer members. Thus, the attachment of both pin and retainer members to the prepared stringer tape end portions is reduced to two operations namely, a threading operation, and a clinching and gate severing operation.

Since the folded tape edge portions are aligned before the threading operation and since the relative positions of the pin and retainer members are fixed by their rigid attachment to the gate whereby the ends of the channels thereof are aligned, but little care need be exercised in threading in the tape portions to the predetermined positions defined by the stop means as described above, whereupon the clinching and gate severing operation may be performed.

It is, of course, to be understood that the above description is merely illustrative and in nowise limiting and that I desire to comprehend within my invention such modifications as are included within the scope of the following claims.

Having thus fully described my invention what I claim as new and desire to secure by U. S. Letters Patent is:

1. In a method of applying to the edge reinforced lower stringer tape ends of a slide fastener the components of a separating end fitting comprising telescopically engageable complementary pin and retainer members, said slide fastener including complementary stringer tapes having thereon detachably engageable fastener members with a slider supported thereon for sliding movement to engage and disengage said fastener members progressively, pulling up the slider of said slide fastener at least partially for connecting said tapes and aligning them longitudinally, removing such lower end portions of the edge reinforcement from each of the fastener stringer tapes that the ends of the remaining edge reinforcements of both tapes are substantially longitudinally aligned, folding the end portions of both tapes over upon themselves substantially at the ends of the remaining edge reinforcements, compressing portions of the folds adjacent the lower ends of the remaining edge reinforcements to decrease the double thickness thereof, fixedly supporting in laterally spaced relation a pin member and a retainer member each having an outwardly directed longitudinal spread-jawed tape edge receiving channel, pulling the connected stringer tapes apart for a substantial distance above the folded portions to free the folded end portions for free manipulation, then simultaneously threading the folded end edge portions of each of said stringer tapes an equal distance into one of said channels and simultaneously clinching said members to said stringer tapes by clinching the jaws of said channels thereto.

2. In a method of providing a slide fastener with a separating end fitting comprising complementary detachably engageable pin and retainer

7

members each attached to one of the edge reinforced stringer tapes of said fastener, casting a blank comprising laterally spaced pin and retainer members fixedly connected in the longitudinally aligned relation desired in the assembled slide fastener by a severable gate and said pin and retainer members having outwardly directed spread-jawed tape end edge receiving channels, threading the end edges of both tapes each into one of said channels, and clinching said spread-jawed channels on the tape portions therein while simultaneously severing the gate from said pin and retainer members.

FREDERICK L. MORROW.

References Cited in the file of this patent

UNITED STATES PATENTS

Number	Name	Date
2,102,031	Retter	Dec. 14, 1937

8

Number	Name	Date
2,115,369	Marinsky	Apr. 26, 1938
2,137,537	McIntosh	Nov. 22, 1938
2,169,609	Kiessling	Aug. 15, 1939
5 2,216,794	Ulrich	Oct. 8, 1940
2,218,091	Marinsky	Oct. 15, 1940
2,219,045	Kiessling	Oct. 22, 1940
2,219,165	Nedal	Oct. 22, 1940
2,302,339	Morin	Nov. 17, 1942
10 2,312,045	Morin	Feb. 23, 1943
2,319,874	Marinsky	May 25, 1943
2,320,566	Carlile	June 1, 1943
2,366,287	Rabinowitz	Jan. 2, 1945
2,397,037	Norkin	Mar. 19, 1946
15 2,409,966	Voity et al.	Oct. 22, 1946
2,474,908	Morin	July 5, 1949