

[54] MOTORCYCLE

[75] Inventors: Koichiro Ban, Tachikawa; Tsunemi Kawashima, Tokyo; Kazunori Yamada, Machida; Toshiharu Shimizu, Tokorozawa, all of Japan

[73] Assignee: Yamaha Hatsudoki Kabushiki Kaisha, Japan

[**] Term: 14 Years

[21] Appl. No.: 194,959

[22] Filed: Oct. 8, 1980

[30] Foreign Application Priority Data

Apr. 23, 1980 [JP] Japan 55-16372

[51] Int. Cl. D12-11

[52] U.S. Cl. D12/110

[58] Field of Search D12/110; 180/219, 223

[56] References Cited

U.S. PATENT DOCUMENTS

D. 252,141 6/1979 Matsuoka et al. D12/110
D. 253,588 12/1979 Ban et al. D12/110

OTHER PUBLICATIONS

Design, 10/56, p. 25, Vespa Motorcycle, center right side of page.

Primary Examiner—James M. Gandy
Attorney, Agent, or Firm—Ostrolenk, Faber, Gerb & Soffen

CLAIM

[57] The ornamental design for a motorcycle, as shown.

DESCRIPTION

FIG. 1 is a front left side perspective view of a motorcycle, showing our new design;
FIG. 2 is a left side elevational view thereof;
FIG. 3 is a right side elevational view thereof;
FIG. 4 is a top plan view thereof;
FIG. 5 is a front elevational view thereof; and
FIG. 6 is a rear elevational view thereof.

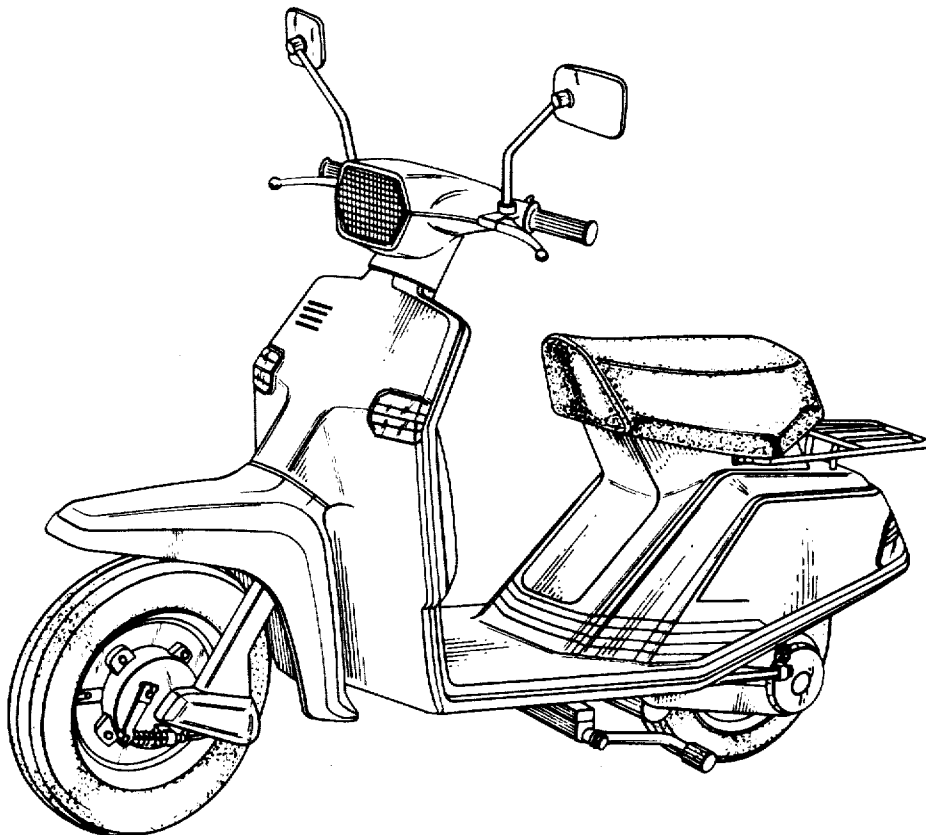

FIG. 1

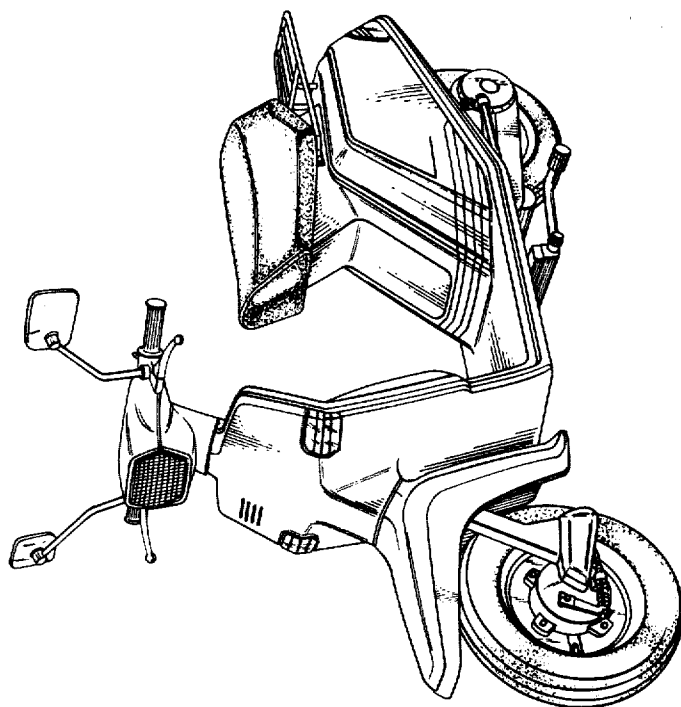

FIG. 2

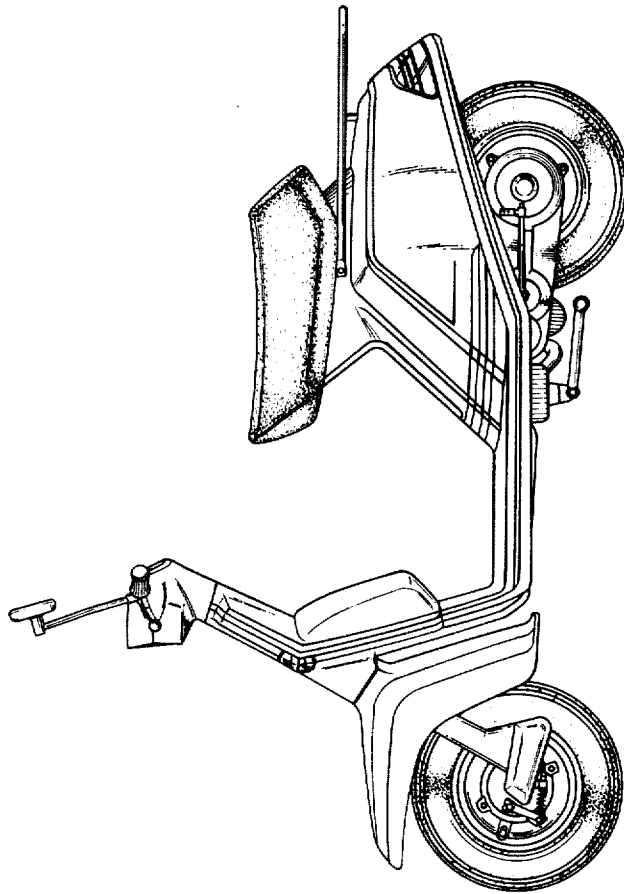

FIG.3

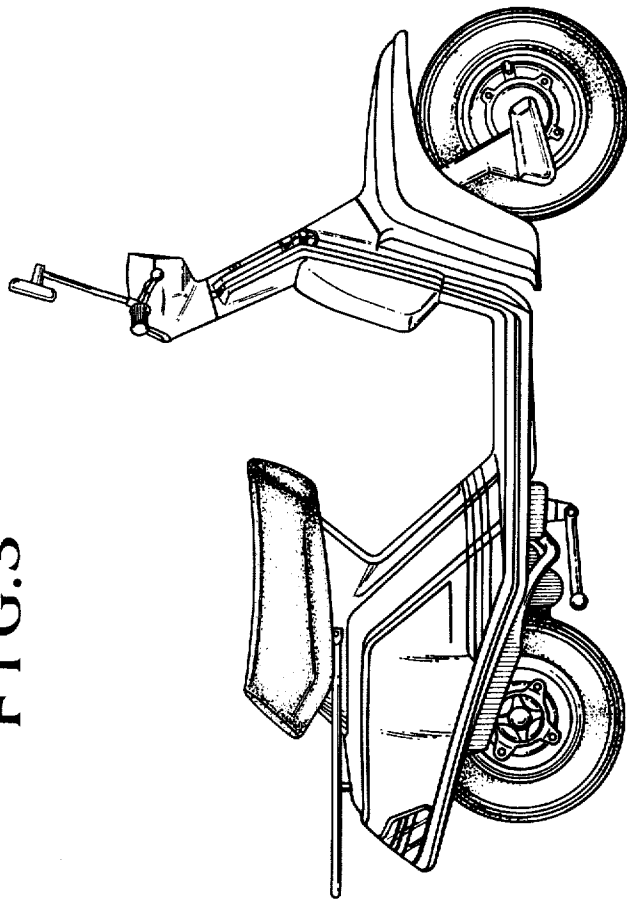

FIG.4

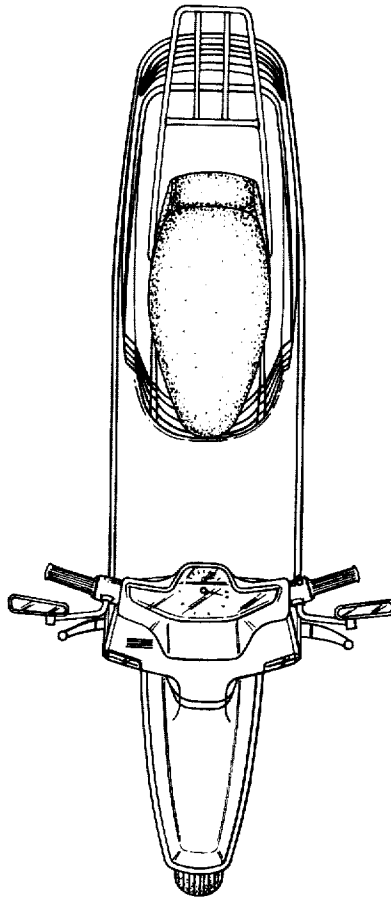

FIG.6

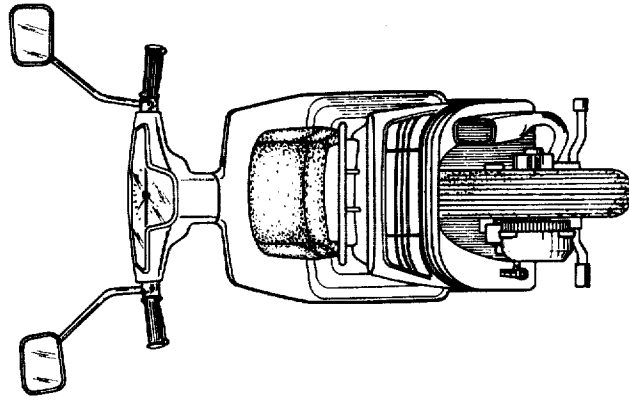

FIG.5

