

(21) Application No: 1402136.4  
(22) Date of Filing: 15.11.2012  
Date Lodged: 07.02.2014

(30) Priority Data:  
(31) 61629224 (32) 15.11.2011 (33) US  
(31) 201220560510 (32) 29.10.2012 (33) CN  
(31) 201210453650 (32) 13.11.2012 (33) CN

(62) Divided from Application No 1220531.6 under section 15(9) of the Patents Act 1977

(51) INT CL:  
A47D 15/00 (2006.01) B60N 2/28 (2006.01)  
B62B 9/24 (2006.01)

(56) Documents Cited:  
US 6398302 B1 US 6155638 A

(58) Field of Search:  
INT CL A47D, B60N, B62B  
Other: EPODOC, WPI

(71) Applicant(s):  
Wonderland Nurserygoods Company Limited  
(Incorporated in China)  
Flat F, 7/F Shing Lee Commercial Building,  
Hong Kong, China

(72) Inventor(s):  
Schantal M Kane  
Curtis Michael Hartenstine

(74) Agent and/or Address for Service:  
Haseltine Lake LLP  
Redcliff Quay, 120 Redcliff Street, BRISTOL, BS1 6HU,  
United Kingdom

(54) Title of the Invention: Adjustable harness and chair therewith  
Abstract Title: Adjustable harness for child's chair

(57) An adjustable harness 2 and a chair 1 therewith are disclosed. The adjustable harness includes an attachment component 52, an adjustment component 54, and a shoulder strap 26. The attachment component is fixedly disposed on a backrest of a chair and comprises a guiding slot 522, relief slots 524 and first protrusions 526. The adjustment component is disposed on the attachment component and capable of being operated to move relative to the attachment component. The adjustment component comprises a sliding member 542 sliding on the guiding member and a second protrusion 544 selectively engageable with the first protrusions. An end of the shoulder strap is connected to the adjustment component. Thereby, the attachment component and the adjustment component function as an adjustment mechanism, by which a user can simply and fast adjust the shoulder strap, so as to solve the problem of tediousness and time consuming in adjusting restraint systems in the prior art.

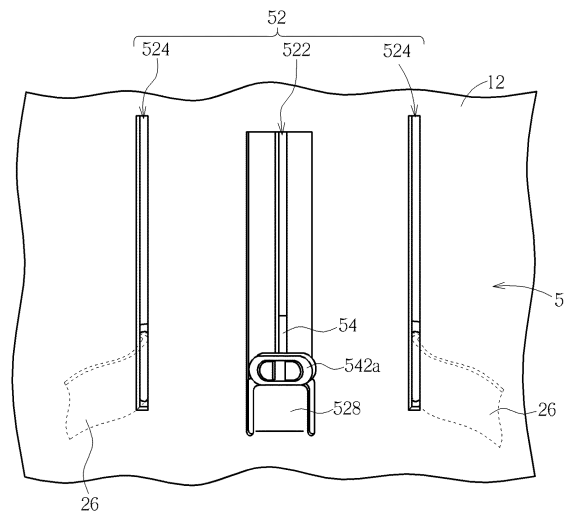

FIG. 11

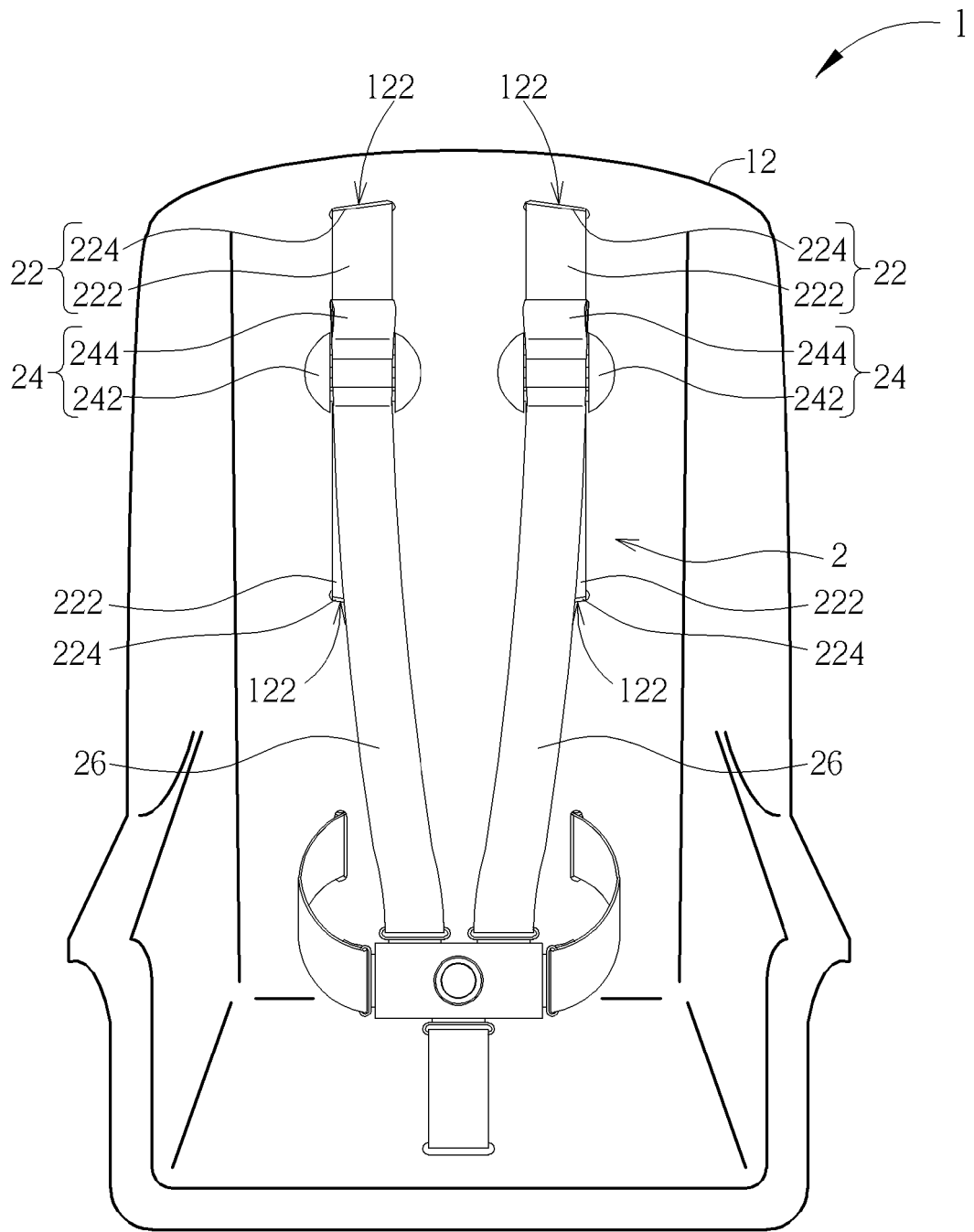

FIG. 1

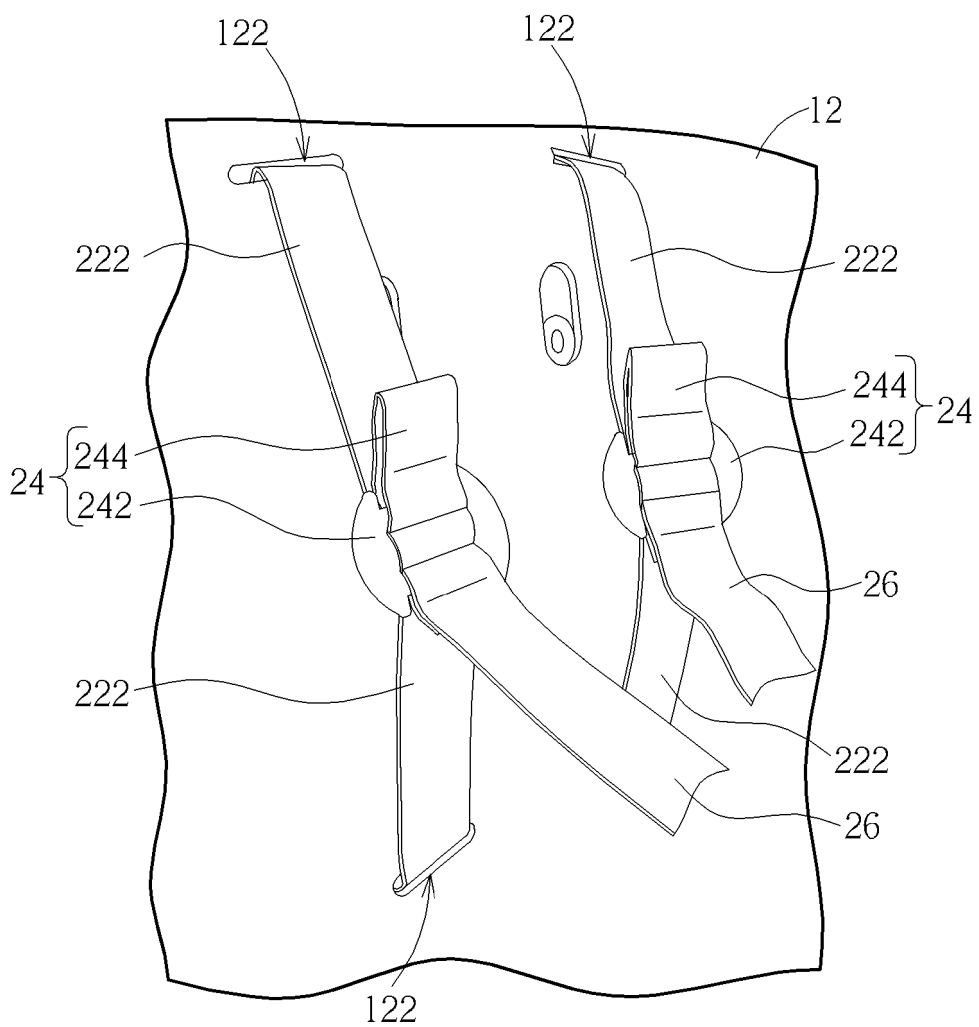

FIG. 2

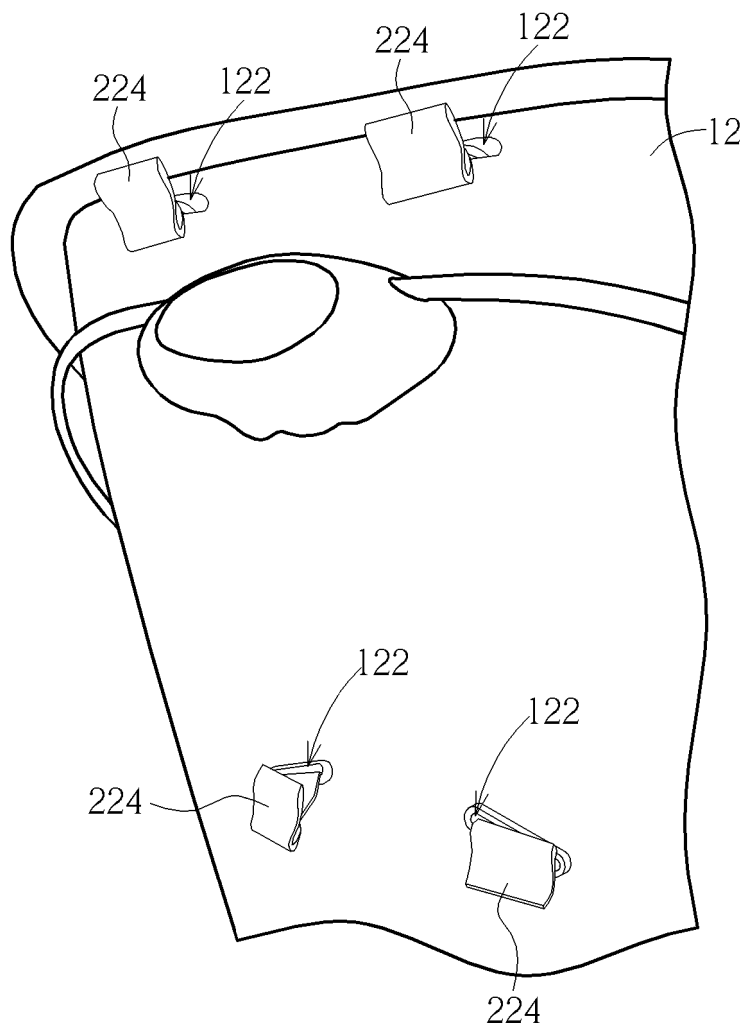

FIG. 3

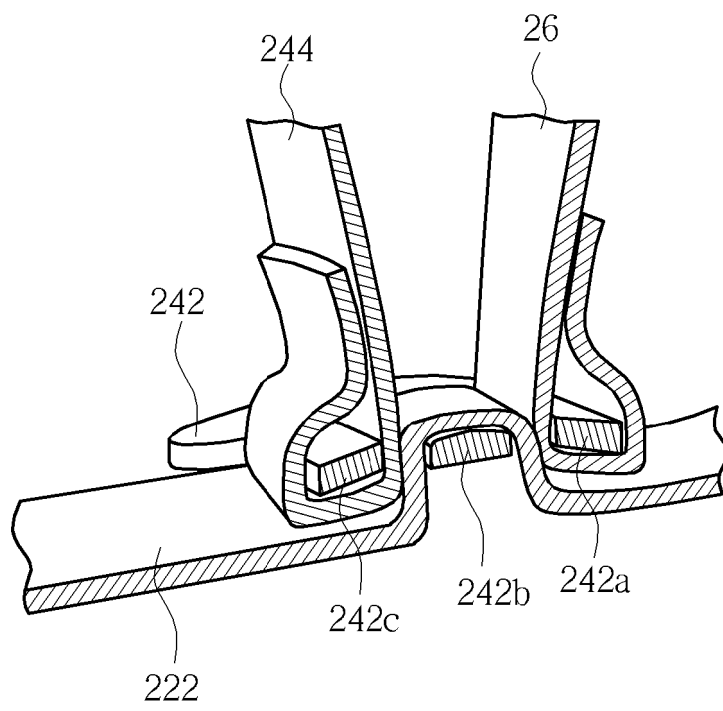

FIG. 4

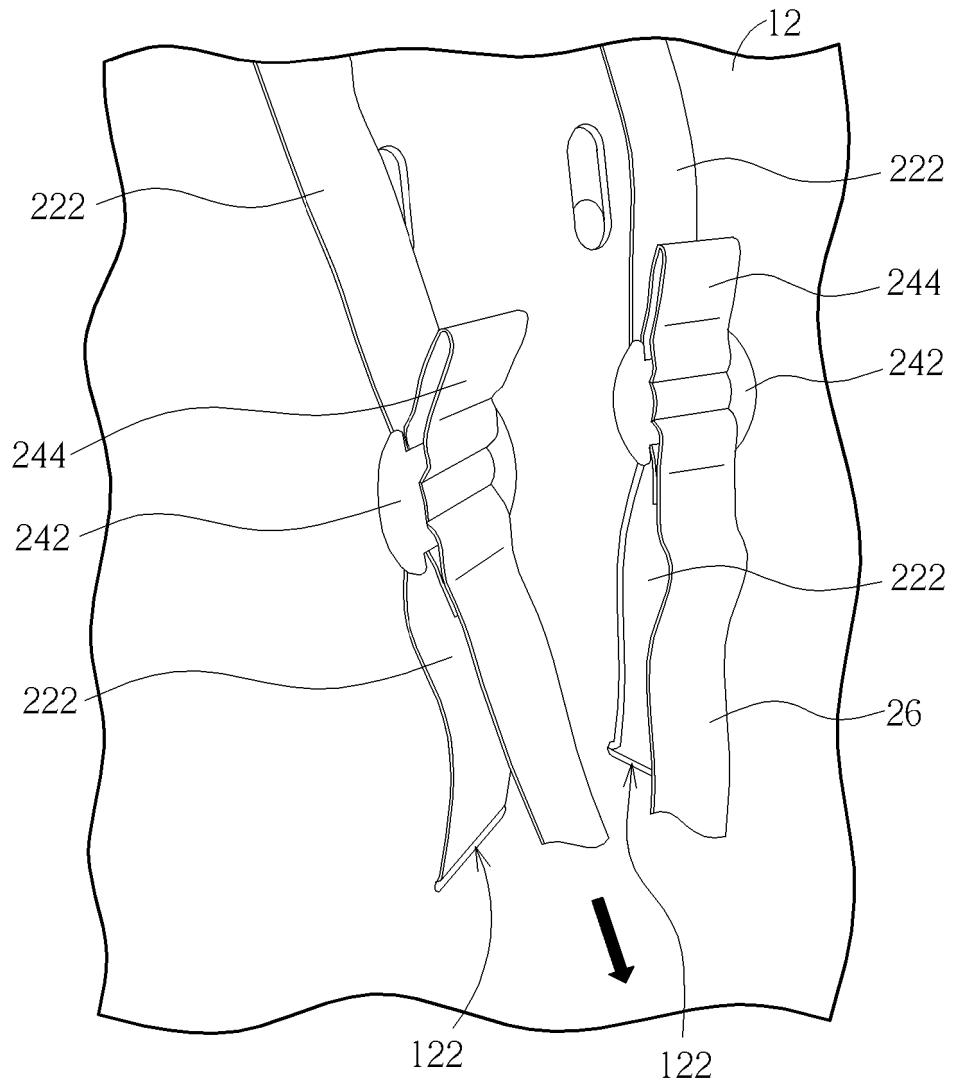

FIG. 5

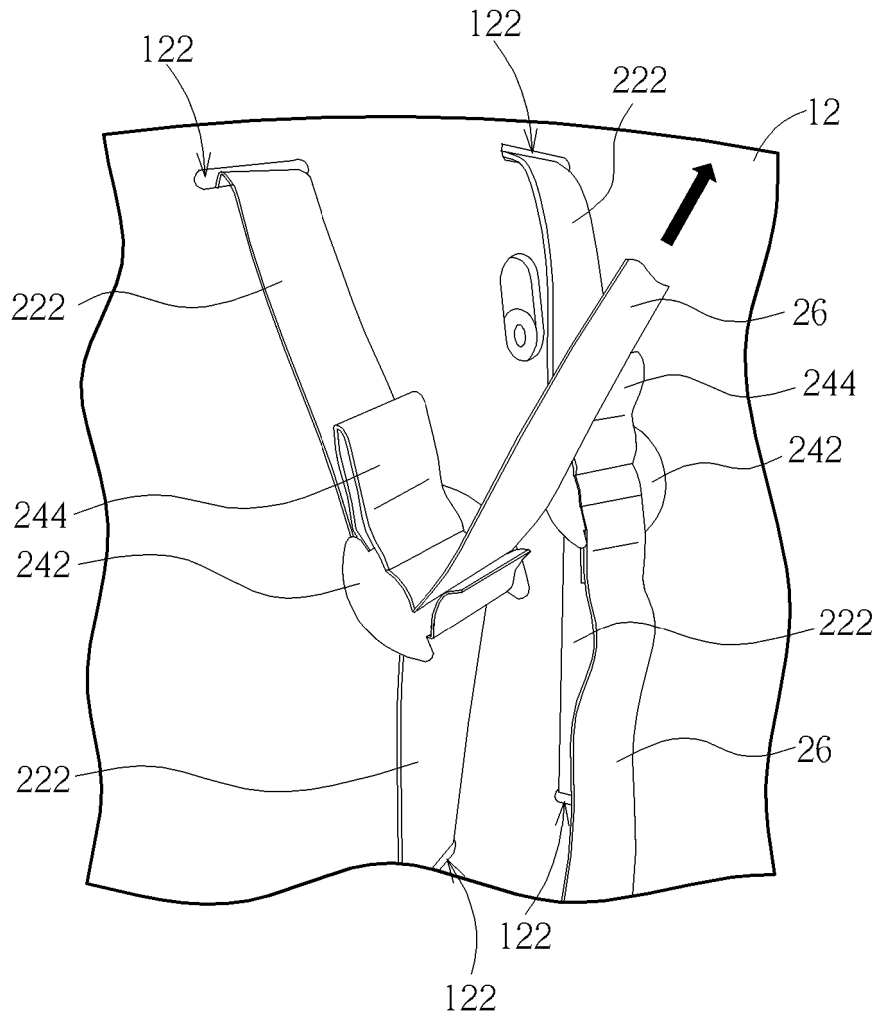

FIG. 6

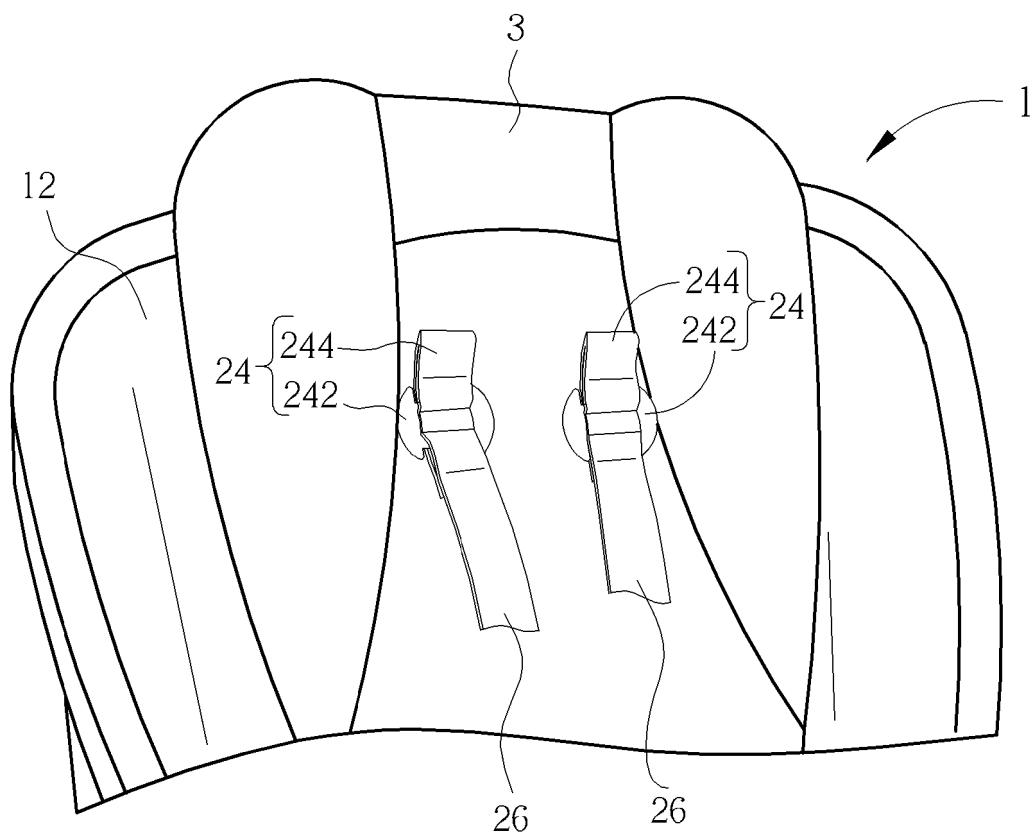

FIG. 7



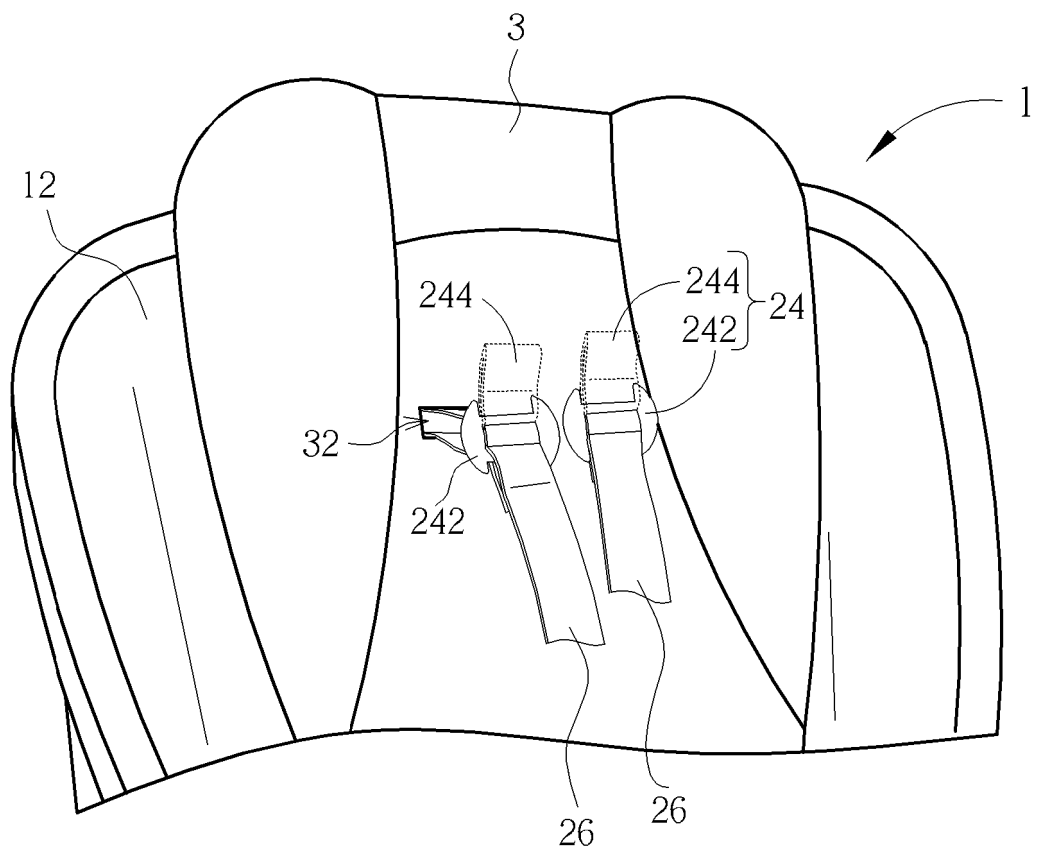

FIG. 8

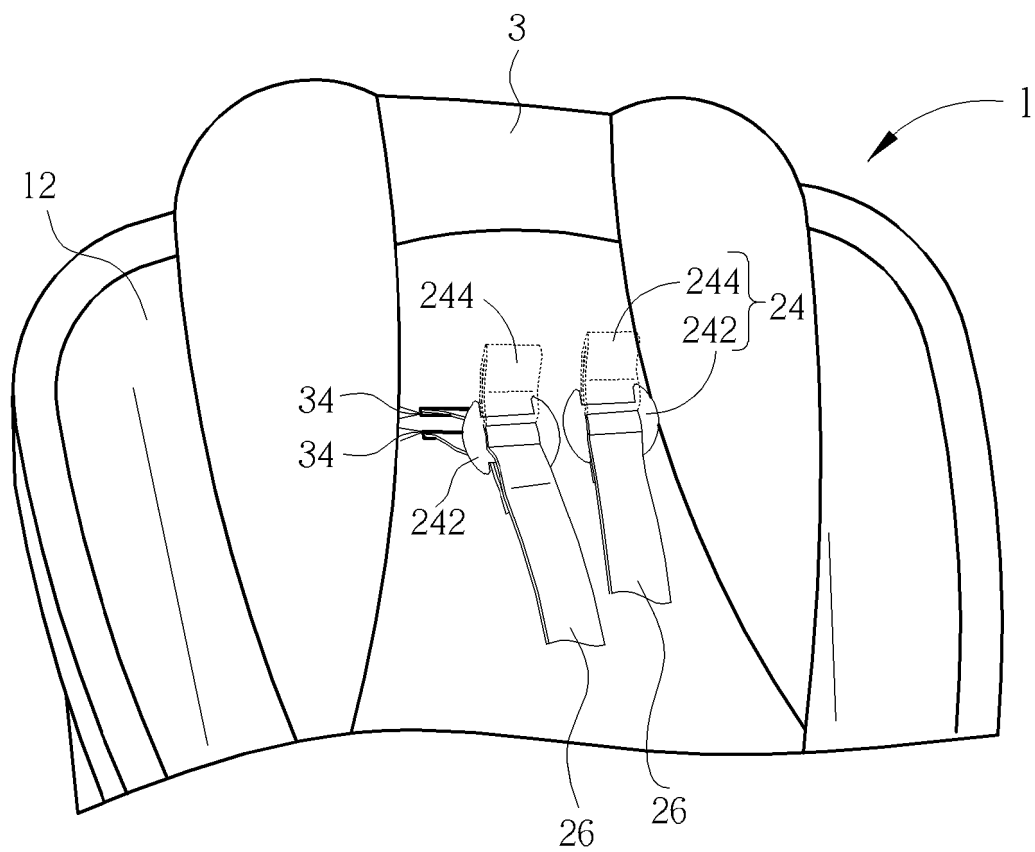

FIG. 9

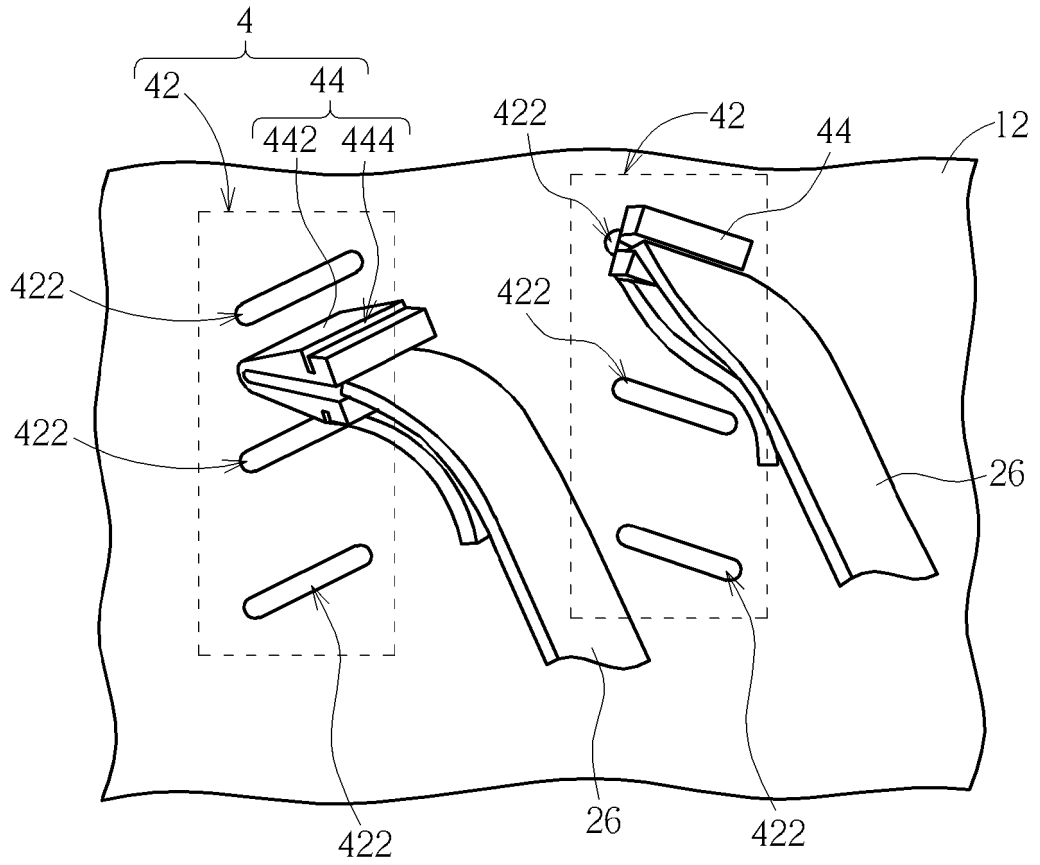

FIG. 10

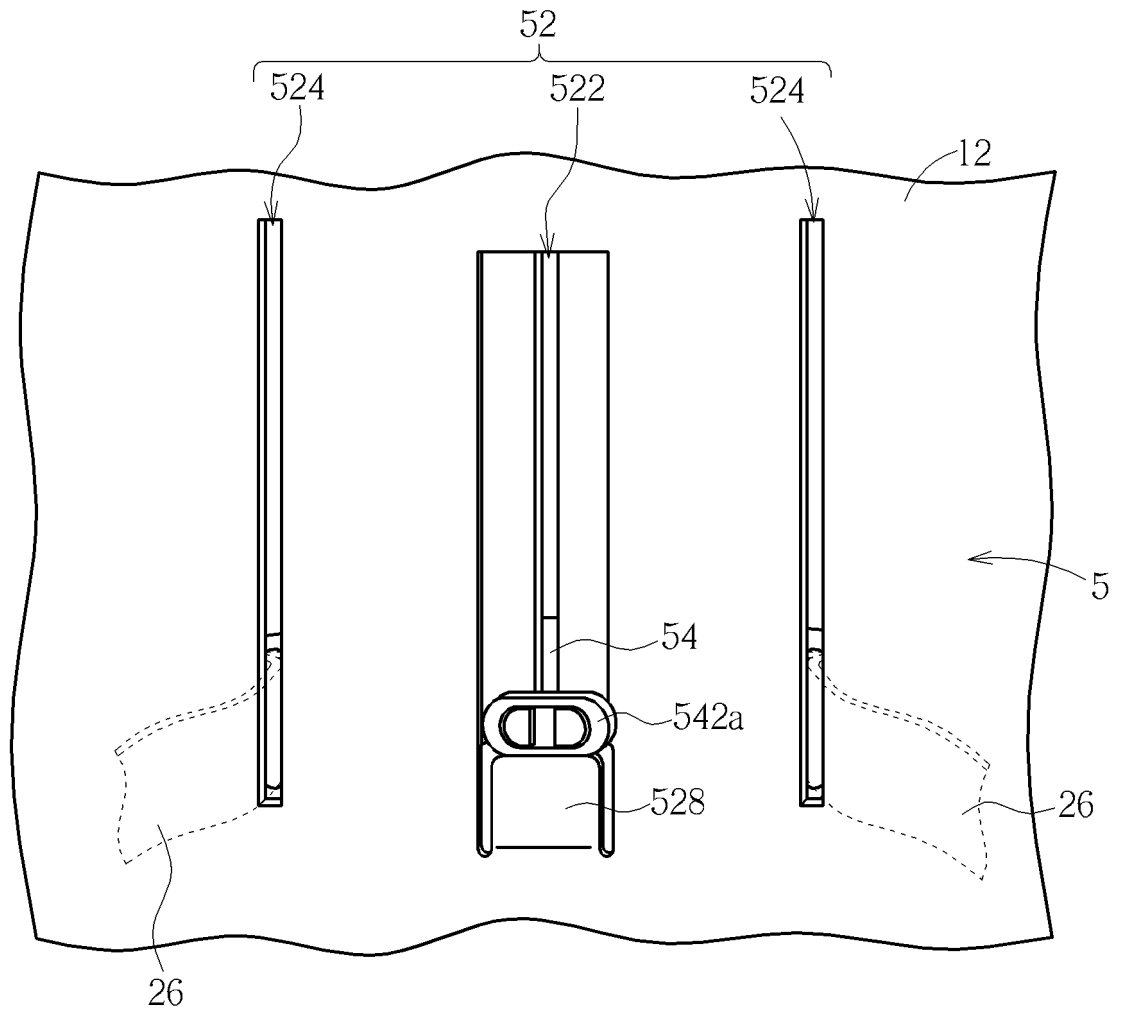

FIG. 11

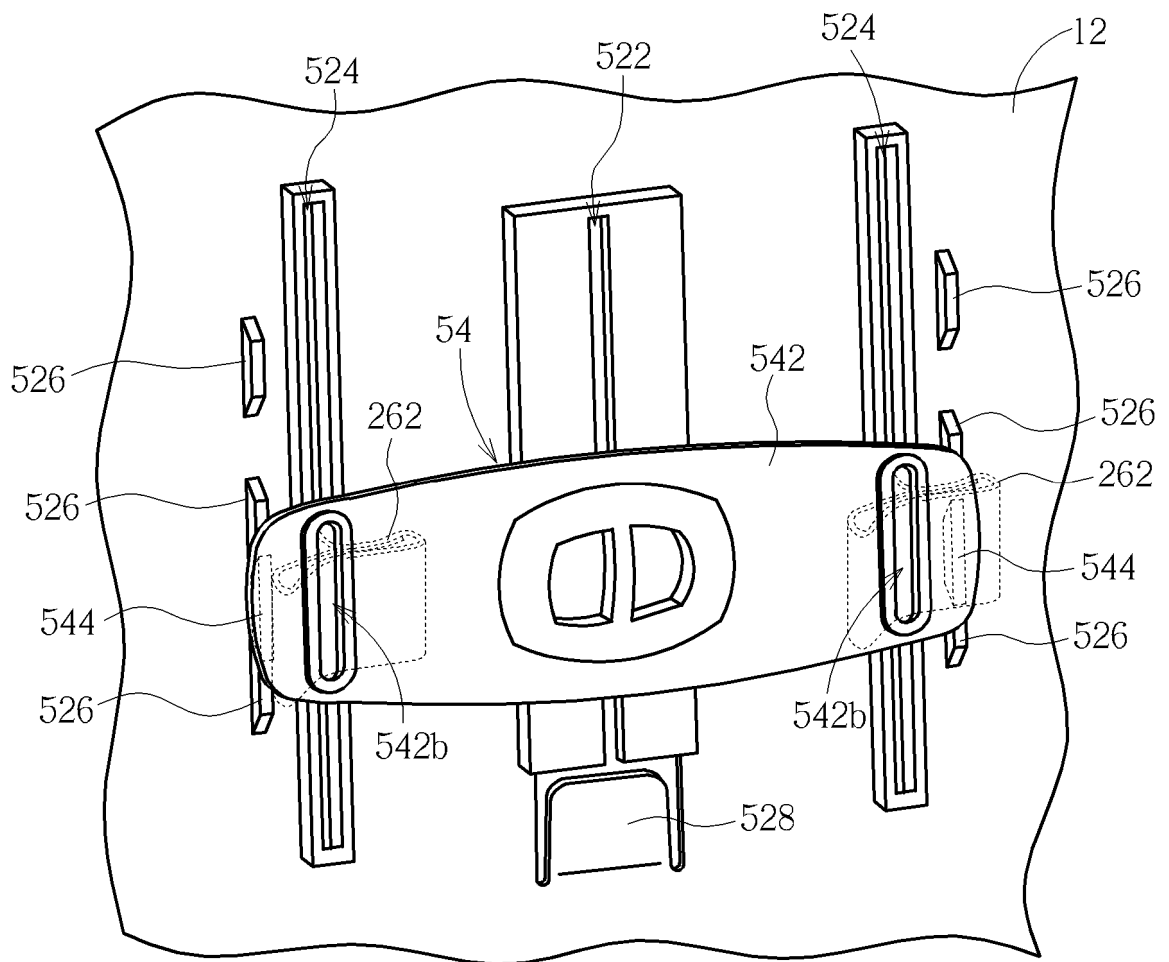

FIG. 12

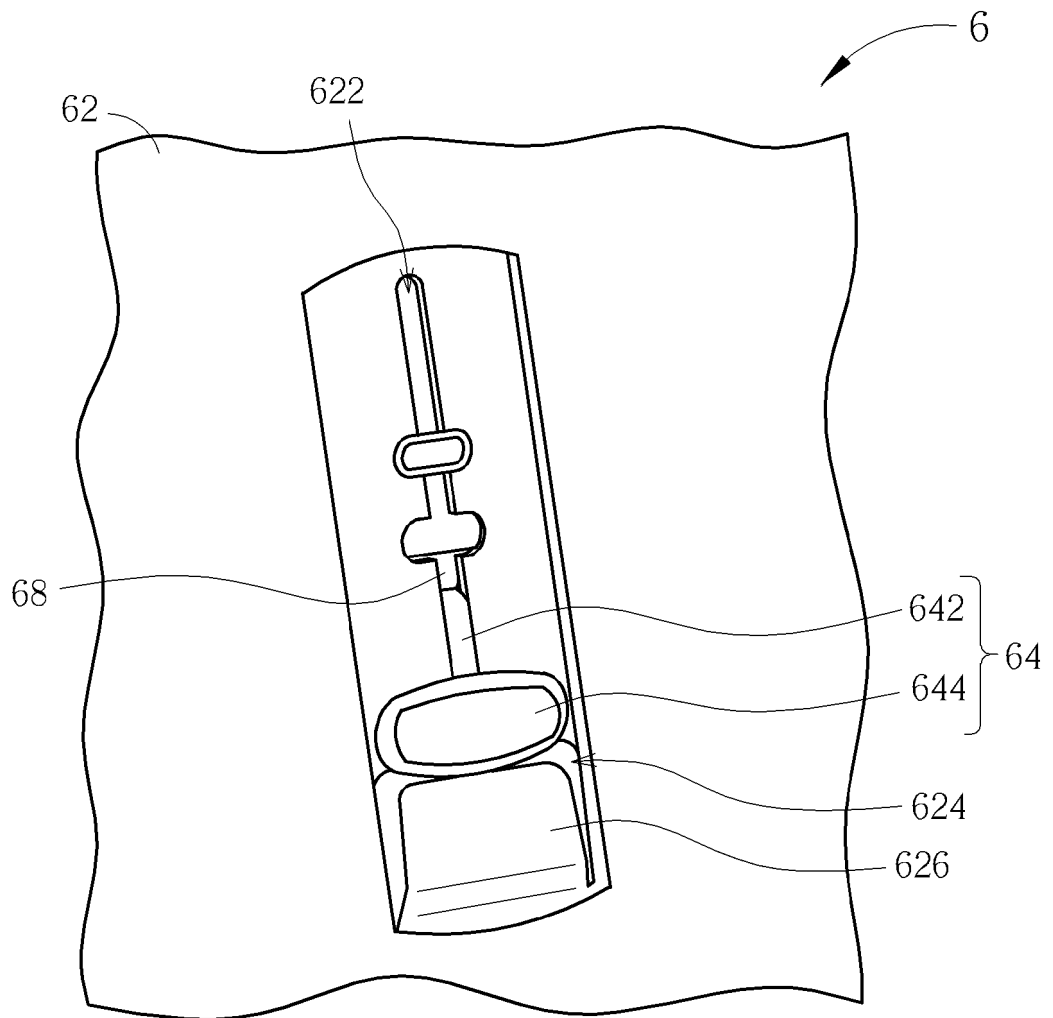

FIG. 13

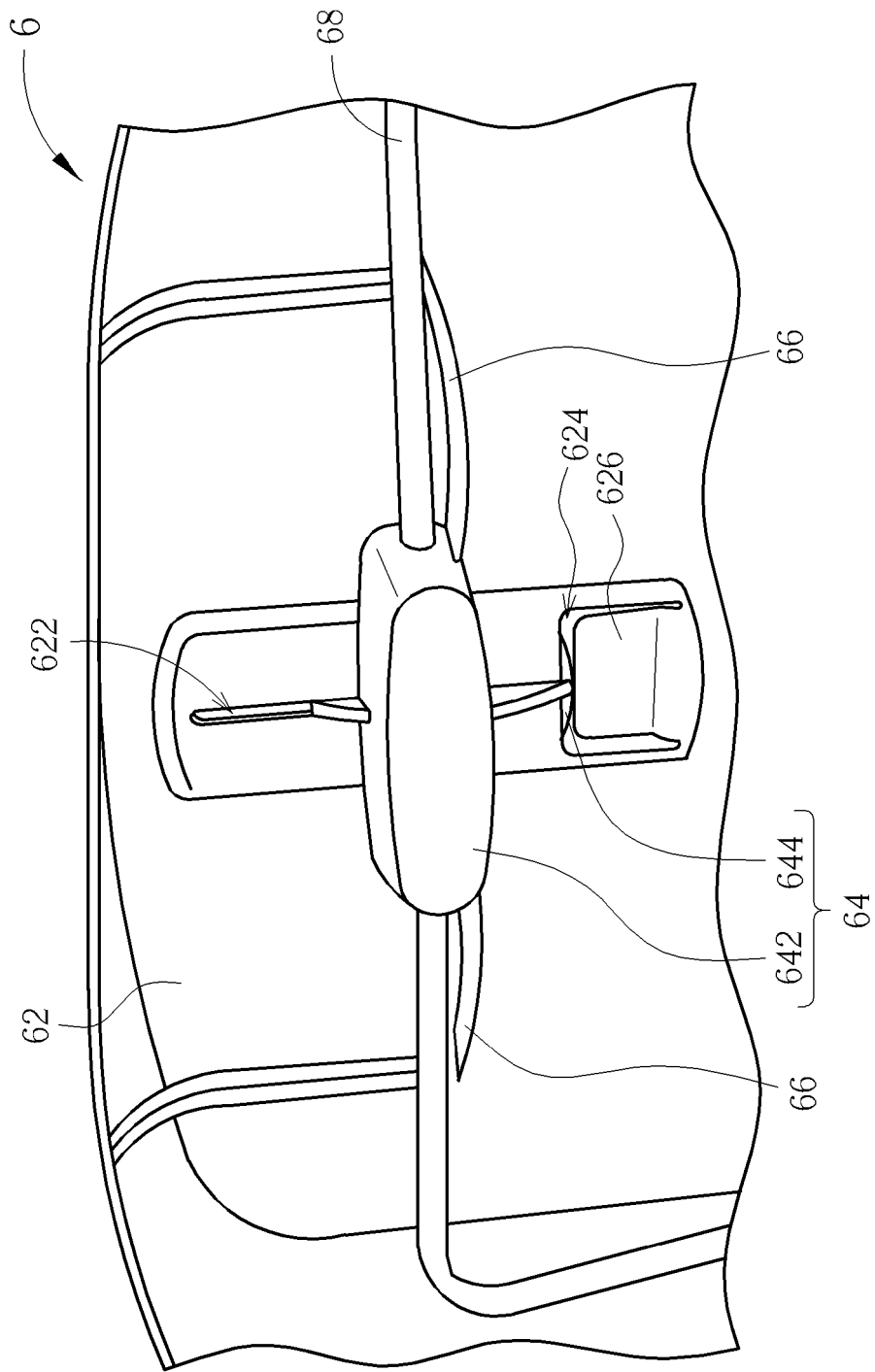

FIG. 14

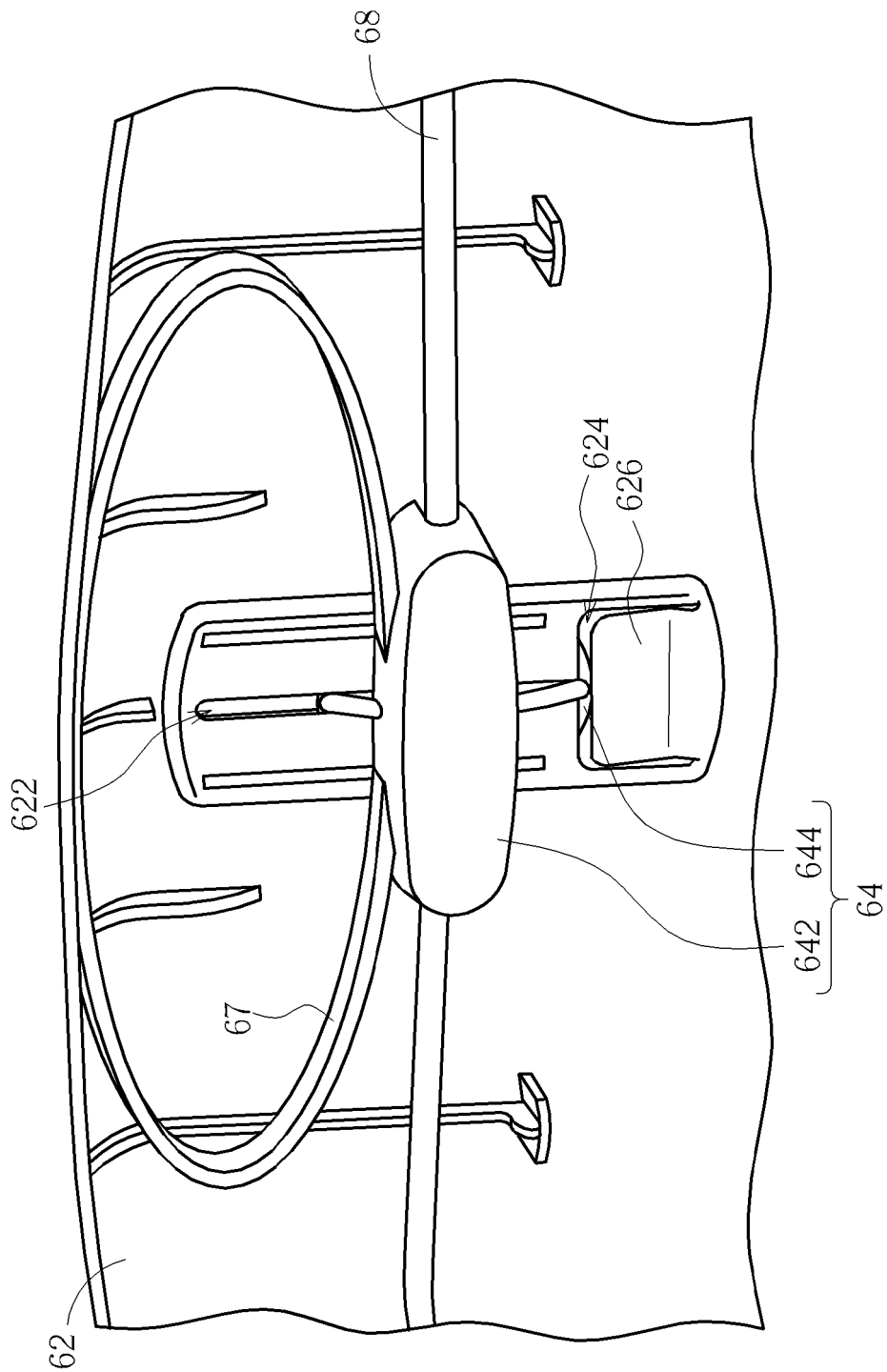

FIG. 15



## Title

ADJUSTABLE HARNESS AND CHAIR THEREWITH

## Cross Reference To Related Applications

[0001] This application claims the benefit of U.S. Provisional Application No. 61/629,224, which was filed on Nov. 15, 2011, and is incorporated herein by reference.

## Background of the Invention

### 1. Field of the Invention

[0002] The invention relates to a chair with safety harness, and especially relates to an adjustable harness and a chair therewith.

### 2. Description of the Prior Art

[0003] High chairs provide a safe and comfortable sitting area that can be used for feeding, crafting activities or simply containing an infant or small child for a period of time. Because of the nature of an elevated seating area, a high chair is usually required to contain a safety restraint system that is adjustable for a certain range in height and weight of infants and children. In addition, restraint systems often contain removable infant inserts for comfort and are currently adjusted by weaving the shoulder straps in and out of slots molded into the backrest which can be tedious and time consuming.

## Summary of the Invention

[0004] An objective of the invention is to provide an adjustable harness, installed on a chair. The adjustable harness uses a vertical adjustment mechanism for adjusting shoulder straps thereof simply and fast.

[0005] The adjustable harness includes an attachment component, an adjustment component, and a shoulder strap. The attachment component is fixedly disposed on a backrest of the chair. The adjustment component is disposed on the attachment component and capable of being

operated to move relative to the attachment component. An end of the shoulder strap is connected to the adjustment component. Thereby, the attachment component and the adjustment component function as an adjustment mechanism. A user can simply and fast operate the adjustment component in coordination with the attachment component to perform adjusting of the shoulder strap, so as to solve the problem of tediousness and time consuming in adjusting restraint systems in the prior art.

[0006] Another objective of the invention is to provide a chair having adjustable harness. Similarly, a user can adjust shoulder straps of the chair simply and fast.

[0007] The chair comprises a backrest, an attachment component, an adjustment component, and a shoulder strap. The attachment component is fixedly disposed on the backrest. The adjustment component is disposed on the attachment component and capable of being operated to move relative to the attachment component. An end of the shoulder strap is connected to the adjustment component. Similarly, the attachment component and the adjustment component function as an adjustment mechanism; a user can adjust the shoulder strap simply and fast by operating the adjustment mechanism.

[0008] These and other objectives of the present invention will no doubt become obvious to those of ordinary skill in the art after reading the following detailed description of the preferred embodiment that is illustrated in the various figures and drawings.

#### Brief Description of the Drawings

[0009] FIG. 1 is a schematic diagram illustrating a chair with an adjustable harness of a first preferred embodiment according to the invention.

[0010] FIG. 2 is an enlarged view of a part of the adjustable harness in FIG. 1.

[0011] FIG. 3 is a schematic diagram illustrating the backside of a

backrest of the chair in FIG. 1.

[0012] FIG. 4 is a sectional view of the adjustment component of the adjustable harness in FIG. 1.

[0013] FIG. 5 is a schematic diagram illustrating a shoulder strap is pulled substantially parallel to an attachment strap of the adjustable harness in FIG. 1.

[0014] FIG. 6 is a schematic diagram illustrating the shoulder strap is pulled non-parallel to the attachment strap of the adjustable harness in FIG. 1.

[0015] FIG. 7 is a schematic diagram illustrating the chair in FIG. 1 equipped with an infant insert.

[0016] FIG. 8 is a schematic diagram illustrating the chair equipped with an infant insert according to another embodiment.

[0017] FIG. 9 is a schematic diagram illustrating the chair equipped with an infant insert according to another embodiment.

[0018] FIG. 10 is a schematic diagram illustrating a part of the chair with an adjustable harness of a second preferred embodiment according to the invention.

[0019] FIG. 11 is a schematic diagram illustrating a part of the chair with an adjustable harness of a third preferred embodiment according to the invention.

[0020] FIG. 12 is a schematic diagram illustrating the backside of the backrest of the chair in FIG. 11.

[0021] FIG. 13 is a schematic diagram illustrating a part of a chair further with a recliner handle of a fourth preferred embodiment according to the invention.

[0022] FIG. 14 is a schematic diagram illustrating the backside of a backrest of the chair in FIG. 13.

[0023] FIG. 15 is a schematic diagram illustrating the backside of a backrest of the chair in FIG. 13 with a different resilient member.

#### Detailed Description

[0024] Please refer to FIGS. 1 through 3. FIG. 1 is a schematic diagram illustrating a chair 1 with an adjustable harness 2 of a first preferred embodiment according to the invention. FIG. 2 is an enlarged

view of a part of the adjustable harness 2. FIG. 3 is a schematic diagram illustrating the backside of a backrest 12 of the chair 1. The adjustable harness 2 is installed on the chair 1 and includes two attachment components 22, two adjustment components 24, and two shoulder straps 26, and other required components. Each shoulder strap 26 corresponds to one attachment 22 and one adjustment components 24. The attachment component 22 is fixedly disposed on the backrest 12. The adjustment component 24 is disposed on the corresponding attachment component 22 and capable of being operated to move relative to the corresponding attachment component 22. An end of the shoulder strap 26 is connected to the corresponding adjustment component, so as to capable of being moved together with the corresponding attachment component 22. Thereby, a user can simply and fast operate the adjustment component in coordination with the corresponding attachment component to perform adjusting of the corresponding shoulder strap 26.

[0025] In the embodiment, the attachment component 22 includes an attachment strap 222 and two retainers 224 at the two ends of the attachment strap 222. The retainers 224 can be made by means of a butterfly sewing method, but the invention is not limited thereto. The backrest 12 has keyed slots 122 corresponding to the retainers 224. The two ends of attachment strap 222 are mounted on the backrest 12 by inserting the retainers 224 into the corresponding keyed slots 122. The attachment strap 222 passes through the adjustment component 24.

[0026] Please also refer to FIG. 4. FIG. 4 is a sectional view of the adjustment component 24. The adjustment component 24 includes a tri-glide buckle 242 and a pulling tab 244. The attachment strap 222 is woven through three bars 242a, 242b and 242c of the tri-glide buckle 242. The end of the shoulder strap 26 is attached by sewing onto the lower one 242a of the three bars 242a, 242b and 242c of the tri-glide buckle 242. The pulling tab 244 is attached by sewing onto the upper one 242c of the three bars 242a, 242b and 242c of the tri-glide buckle

242. Thereby, the shoulder straps 26 can move together with the tri-glide buckles 242 without detaching the adjustable harness 2 from the backrest 12.

[0027] Please refer to FIG. 5 and FIG. 6 for the movement mechanism of the tri-glide buckle 242. FIG. 5 is a schematic diagram illustrating the shoulder strap 26 is pulled substantially parallel to the attachment strap 222. FIG. 6 is a schematic diagram illustrating the shoulder strap 26 is pulled non-parallel to the attachment strap 222. The pulling direction is indicated by an arrow in the figures. When the tri-glide buckle 242 is applied with a force substantially parallel to the attachment strap 222 away from the tri-glide buckle 242, the tri-glide buckle 242 can slide on the attachment strap 222 for adjusting the shoulder strap 26. In practice, the parallel force can be produced by pulling the shoulder strap 26 downward (as shown in FIG. 5) or pulling the pulling tab 244 upward. Therein, the pulling tab 244 can assist with an upward adjustment of the tri-glide buckle 242.

[0028] In another aspect, when the tri-glide buckle 242 is applied with a force non-parallel to the attachment strap 222 away from the tri-glide buckle 242, the tri-glide buckle 242 can lock the attachment strap 222 for maintaining the relative position of the shoulder strap 26 to the attachment component 22. In practice, the non-parallel force can be produced by pulling the shoulder strap 26 upward, as shown in FIG. 6. In a practical application, the shoulder strap 26 is wound around the front of the child seated on the chair 1, so that the shoulder strap 26 is connected to the tri-glide buckle 242 non-parallel to the attachment strap 222. If the child wants to get out of the chair 1, the shoulder strap 26 will be dragged by the child to pull the tri-glide buckle 242 with a force non-parallel to the attachment strap 222. Such non-parallel force makes the tri-glide buckle 242 lock the attachment strap 222, so the child can be firmly seated on the chair 1 for safety.

[0029] In addition, an infant insert 3 can be attached behind the tri-glide buckle 242 by means of weaving the adjustable harness 2 through button holes formed on the infant insert 3 and fixing the infant insert 3 between the tri-glide buckle 242 and the attachment strap 222 opposite to the shoulder strap 26, as shown in FIG. 7. Because the infant insert 3 is disposed opposite to the shoulder strap 26, infant insert 3 will not interfere with the adjustment of the shoulder straps 26. Furthermore, this configuration allows the infant insert 3 to move with the shoulder straps 26 during the adjustment of the shoulder straps 26. Therefore, when a user adjusts the shoulder straps 26, it is unnecessary for the user to adjust the infant insert 3 in addition. In practice, the infant insert 3 thereon can form one button hole 32 corresponding to one tri-glide buckle 242. The button hole 32 allows the attachment strap 222 to pass through, such that the infant insert 3 can be attached between the attachment strap 222 and the tri-glide buckle 242, as shown in FIG. 8. Therein, the left tri-glide buckle 242 departs from the infant insert 3 in a distance for showing a clear illustration of the attachment strap 222 passing through the button hole 32. In the case, a structural constraining force exists between the infant insert 3 and the tri-glide buckle 242. The user can directly pull the infant insert 3 upward or downward to make the tri-glide buckle 242 move relative to the attachment strap 222, so in the embodiment, the pulling tab 244 can be skipped and is shown in dashed lines in FIG. 8. In addition, in practice, the infant insert 3 thereon can form two button holes 34 corresponding to one tri-glide buckle 242. The two button holes 34 allows the attachment strap 222 to pass through respectively, such that the infant insert 3 can be attached between the attachment strap 222 and the tri-glide buckle 242 more stably, as shown in FIG. 9. Therein, the left tri-glide buckle 242 departs from the infant insert 3 in a distance for showing a clear illustration of the attachment strap 222 passing through the button holes 34. Similarly, the user can directly pull the infant insert 3 upward or downward to adjust the position of the tri-glide buckle 242 relative to the attachment strap 222. In the case, the pulling tab 244 also can be skipped and is shown

in dashed lines in FIG. 9.

[0030] Please refer to FIG. 10, which is a schematic diagram illustrating a part of the chair 1 with an adjustable harness 4 of a second preferred embodiment according to the invention. The adjustable harness 4 is similar in logical structure to the adjustable harness 2. The following will be concentrated on the difference therebetween. For other description of the adjustable harness 4, please refer to the relevant descriptions of the adjustable harness 2. The difference between the adjustable harness 4 and the adjustable harness 2 is that the adjustable harness 4 uses a different adjustment mechanism. The adjustable harness 4 includes two attachment components 42 (indicated by frames in dashed lines) and two corresponding adjustment components 44. The attachment component 42 includes a plurality of keyed slots 422, directly formed on the backrest 12. The corresponding adjustment component 44 includes a flexible member 442 and a groove 444. In the embodiment, the flexible member 442 is realized by a V-shaped clip which has a wedge portion and a blocking portion. The groove 444 is formed between the wedge portion and the blocking portion. The end of the shoulder strap 26 is fixed on the flexible member, precisely at the blocking portion.

[0031] The flexible member 242 is resiliently compressible so as to be selectively inserted into one of the keyed slots 422. Because of the resilience of the flexible member 442, the flexible member 442 will decompress after the wedge portion fully passes through the keyed slot 422, such that the groove 444 is engaged with the keyed slot 422 for locking thereto. At this moment, the edge of the keyed slot 422 is embedded in the groove 444, and the wedge portion and the blocking portion are located at opposite sides of the backrest 12, so that the adjustment component 44 is firmly attached to the backrest 12. To remove the shoulder strap 26, the flexible member 442 must be manually compressed such as by compressing the blocking portion and removed from the keyed slot 422. Therefore, a user can easily operate the flexible member 442 by single hand, providing convenient

operation. In addition, similarly, an infant insert can be attached to the adjustment component 44 by means of weaving and fixing the infant insert through button holes.

[0032] Please refer to FIG. 11 and FIG. 12. FIG. 11 is a schematic diagram illustrating a part of the chair 1 with an adjustable harness 5 of a third preferred embodiment according to the invention. FIG. 12 is a schematic diagram illustrating the backside of the backrest 12 of the chair 1. The adjustable harness 5 is similar in logical structure to the adjustable harness 2. The difference between the adjustable harness 5 and the adjustable harness 2 is that the adjustable harness 5 uses a different sliding adjustment mechanism. The following will be concentrated on the difference therebetween. For other description of the adjustable harness 5, please refer to the relevant descriptions of the adjustable harness 2. The adjustable harness 5 includes an attachment component 52 and a corresponding adjustment component 54. The attachment component 52 includes a guiding slot 522 and two relief slots 524; in the embodiment, the guiding slot 522 and the relief slots 524 are directly formed on the backrest 12 and extend parallel.

[0033] The adjustment component 54 includes a sliding member 542. The sliding member 542 has a retaining part 542a at its middle portion, passing through the guiding slot 522 such that the sliding member 542 can vertically slide on the guiding slot. The sliding member 542 also has two keyed slots 542b formed at its two side portions and corresponding to the two relief slots 524 respectively. The shoulder straps 26 (shown by dashed lines in the figures) are attached to the two side portions of the sliding member 542 respectively. The shoulder strap 26 has a retainer 262 at its end for being attached to the sliding member 542. The retainer 262 can be made by means of a butterfly sewing method, but the invention is not limited thereto. The retainer 262 passes through the corresponding relief slot 524 to be fixed at the corresponding keyed slot 542b. Thereby, the shoulder straps 26 can move together with the sliding member 542 without detaching the



adjustable harness 5 from the backrest 12.

[0034] In the embodiment, the attachment component 52 further includes a plurality of first ramped protrusions 526, formed on the backrest 12. The first ramped protrusions 526 are separately arranged parallel to the relief slot 524 (or the guiding slot 522). The adjustment component 54 includes two second ramped protrusions 544 (shown by hidden lines in FIG. 12), disposed on the sliding member 542 and corresponding to the first ramped protrusions 526. The sliding member 542 can provide a certain elastic deflection at its side portions, so the second ramped protrusion 526 is capable of moving with the sliding member 542 to be selectively embedded between the first ramped protrusions 526 for locating the sliding member 542. Furthermore, to avoid the disengagement of the sliding member 542 from the guiding slot 522, the attachment component 52 further includes a one-time snap 526 at a bottom opening end of the guiding slot 522 for obstructing the retaining part 542a. In addition, similarly, an infant insert can be attached to the retaining part 542a from the front side of the backrest 12.

[0035] Please refer to FIG. 13 and FIG. 14. FIG. 13 is a schematic diagram illustrating a part of a chair 6 further with a recliner handle of a fourth preferred embodiment according to the invention. FIG. 14 is a schematic diagram illustrating the backside of a backrest 62 of the chair 6. The chair 6 can be provided with one of the above-mentioned adjustable harness 2, 4 and 5. In principle, the chair 1 in the above embodiments can be used as the chair 6. The descriptions for the adjustable harness 2, 4 and 5 will not be described herein. The following will be concentrated on the recliner handle. The chair 6 includes the backrest 62, a seat plate, a recliner mechanism, a single-structured handle 64 and a resilient member 66. The backrest 62 has a guiding slot 622, formed on the backrest 62, an inlet space 624, formed on the backrest 62 and communicating with the guiding slot 622, and a one-time snap 626, disposed at the inlet space 624. The backrest 62 is disposed above the seat plate. The recliner

mechanism is used for constraining the backrest 62 to be disposed at a slanted angle relative to the seat plate and includes a recliner wire 68. The single-structured handle 64 is connected to the recliner mechanism and passes through and slides on the guiding slot 622, for driving the recliner mechanism.

[0036] In the embodiment, the single-structured handle 64 is molded in one piece and has a handle body 642 and a retaining portion 644, disposed to be connected with each other at two sides of the guiding slot 622. The handle body 642 is connected to the recliner wire 68 for driving the recliner mechanism. The profile of the inlet space 624 is larger than the profile of the retaining portion 644. In practice, the single-structured handle 64 is assembled to the guiding slot 622 by inserting the retaining portion 644 into the inlet space 624 and moving upward the handle body 642. When the single-structured handle 64 is normally assembled to the guiding slot 622, the one-time snap 626 can obstruct the retaining portion 644 from getting into the inlet space 624 for preventing the single-structured handle 64 from being disengaged from the guiding slot 622.

[0037] In the embodiment, the resilient member 66 has two arm portions. Each arm portion is connected to the handle body 642 and the backrest 62 and is made of resilient material so as to be capable of being resiliently deformed by moving the single-structured handle 64 along the guiding slot 622. In the embodiment, each arm portion is bar-shaped and can serve the same function and force as a spring. In practice, the resilient member 66 can be molded together with the single-structured handle 64. In such case, one end of the arm portion is molded into the handle body 642; the other end can be constrained on the backrest 62 such as by inserting into a slot formed on the backrest 62. Thereby, the resilient member 66 can provide a restoring force to the single-structured handle 64 when the single-structured handle 64 moves. Therefore, the assembly of the single-structured handle 64 and the resilient member 66 onto the backrest 62 can be implemented without additional fixtures such as screws.

[0038] It is added that, the resilient member of the invention is not limited to the above embodiment. In practice, the resilient member can be molded in various different forms to achieve a force on the recliner wire 68 through the handle body 642. For example, the resilient member can be molded in a ring-shaped structure 67, as shown in FIG. 15. When the handle body 642 is moved upward to drive the recliner mechanism through the recliner wire 68, the ring-shaped structure 67 is compressed. So the compressed ring-shaped structure 67 can applied a downward force on the recliner wire 68 through the handle body 642.

[0039] Those skilled in the art will readily observe that numerous modifications and alterations of the device and method may be made while retaining the teachings of the invention. Accordingly, the above disclosure should be construed as limited only by the metes and bounds of the appended claims.

[0040] For the avoidance of doubt, the subject-matter of the present invention includes subject-matter as defined in the following numbered paragraphs (hereafter "para."):

Para. 1. An adjustable harness, installed on a chair, the adjustable harness comprising:

an attachment component, fixedly disposed on a backrest of the chair;

an adjustment component, disposed on the attachment component and capable of being operated to move relative to the attachment component; and

a shoulder strap, an end of the shoulder strap being connected to the adjustment component.

Para. 2. The adjustable harness of Para. 1, wherein the attachment component comprises an attachment strap, two ends of the attachment strap are mounted on the backrest, and the attachment strap passes through the adjustment component.

Para. 3. The adjustable harness of Para. 2, wherein the adjustment component comprises a tri-glide buckle, the attachment strap is woven through three bars of the tri-glide buckle, the end of the shoulder strap is attached onto a lower one of the three bars.

Para. 4. The adjustable harness of Para. 3, wherein the adjustment component comprises a pulling tab, attached onto an upper one of the three bars.

Para. 5. The adjustable harness of Para. 3, further comprising an infant insert, attached between the tri-glide buckle and the attachment strap opposite to the shoulder strap.

Para. 6. The adjustable harness of Para. 1, wherein the attachment component comprises a plurality of keyed slots, disposed on the backrest, the adjustment component comprises a flexible member and a groove, formed on the flexible member, the flexible member is resiliently compressible so as to be selectively inserted into one of the keyed slots and decompress such that the groove is engaged with the keyed slot for locking thereto, and the end of the shoulder strap is fixed on the flexible member.

Para. 7. The adjustable harness of Para. 1, wherein the attachment component comprises a guiding slot, disposed on the backrest, the adjustment component comprises a sliding member, sliding on the guiding slot, and the end of the shoulder strap is fixed on the sliding member.

Para. 8. The adjustable harness of Para. 7, wherein the attachment component comprises a relief slot, disposed on the backrest and extending parallel to the guiding slot, and the end of the shoulder strap passes through the relief slot to be fixed on the sliding member.

Para. 9. The adjustable harness of Para. 8, wherein the attachment component comprises a plurality of first ramped protrusions, disposed on the backrest, the adjustment component comprises a second ramped protrusion, disposed on the sliding member, and the second ramped protrusion is capable of moving with the sliding member to be selectively embedded between the first ramped protrusions.

Para. 10. The adjustable harness of Para. 8, further comprising an infant insert, attached to the sliding member from a front side of the backrest.

Para. 11. A chair, comprising:

a backrest;

an attachment component, fixedly disposed on the backrest;

an adjustment component, disposed on the attachment component and capable of being operated to move relative to the attachment component; and

a shoulder strap, an end of the shoulder strap being connected to the adjustment component.

Para. 12. The chair of Para. 11, wherein the attachment component comprises an attachment strap, two ends of the attachment strap are mounted on the backrest, and the attachment strap passes through the adjustment component.

Para. 13. The chair of Para. 12, wherein the adjustment component comprises a tri-glide buckle, the attachment strap is woven through three bars of the tri-glide buckle, the end of the shoulder strap is attached onto a lower one of the three bars.

Para. 14. The chair of Para. 13, wherein the adjustment component comprises a pulling tab, attached onto an upper one of the tree bars.

Para. 15. The chair of Para. 13, further comprising an infant insert, attached between the tri-glide buckle and the attachment strap opposite to the shoulder strap.

Para. 16. The chair of Para. 11, wherein the attachment component comprises a plurality of keyed slots, disposed on the backrest, the adjustment component comprises a flexible member and a groove, formed on the flexible member, the flexible member is resiliently compressible so as to be selectively inserted into one of the keyed slots and decompress such that the groove is engaged with the keyed slot for locking thereto, and the end of the shoulder strap is fixed on the flexible member.

Para. 17. The chair of Para. 11, wherein the attachment component comprises a guiding slot, disposed on the backrest, the adjustment component comprises a sliding member, sliding on the guiding slot, and the end of the shoulder strap is fixed on the sliding member.

Para. 18. The chair of Para. 17, wherein the attachment component comprises a relief slot, disposed on the backrest and extending parallel to the guiding slot, and the end of the shoulder strap passes through the relief slot to be fixed on the sliding member.

Para. 19. The chair of Para. 18, wherein the attachment component comprises a plurality of first ramped protrusions, disposed on the backrest, the adjustment component comprises a second ramped protrusion, disposed on the sliding member, and the second ramped protrusion is capable of moving with the sliding member to be selectively embedded between the first ramped protrusions.

Para. 20. The chair of Para. 18, further comprising an infant insert, attached to the sliding member at a front side of the backrest.

Para. 21. The chair of Para. 11, wherein the backrest has a guiding slot and an inlet space, communicating with the guiding slot, and

the chair further comprises:

- a seat plate, the backrest being disposed above the seat plate;
- a recliner mechanism, for constraining the backrest to be disposed at a slanted angle relative to the seat plate;
- a single-structured handle, connected to the recliner mechanism and passing through and sliding on the guiding slot, the single-structured handle having a handle body and a retaining portion, disposed to be connected with each other at two sides of the guiding slot, a profile of the inlet space being larger than a profile of the retaining portion;
- and
- a resilient member, connected to the handle body and the backrest and capable of being resiliently deformed by moving the single-structured handle along the guiding slot.

Para. 22. The chair of Para. 21, wherein the resilient member is molded together with the single-structured handle.

Para. 23. The chair of Para. 21, wherein the resilient member is bar-shaped or ring-shaped.

Para. 24. The chair of Para. 21, further comprising a one-time snap, disposed at the inlet space, obstructing the retaining portion from getting into the inlet space.

## Claims

What is claimed is:

1. An adjustable harness, installed on a chair, the adjustable harness comprising:
  - an attachment component comprising a guiding slot, a relief slot extending parallel to the guiding slot, and a plurality of first ramped protrusions, fixedly disposed on a backrest of the chair;
  - an adjustment component disposed on the attachment component and capable of being operated to move relative to the attachment component, wherein the adjustment component comprises a sliding member, sliding on the guiding slot, and a second ramped protrusion disposed on the sliding member to be selectively embedded between the first ramped protrusions; and
  - a shoulder strap, wherein the end of the shoulder strap passes through the relief slot to be fixed on the sliding member.
2. The adjustable harness of claim 1, further comprising an infant insert, attached to the sliding member from a front side of the backrest.
3. A chair, comprising:
  - a backrest;
  - an attachment component comprising a guiding slot, a relief slot extending parallel to the guiding slot, and a plurality of first ramped protrusions, disposed fixedly on the backrest;
  - an adjustment component disposed on the attachment component and capable of being operated to move relative to the attachment component, wherein the adjustment component comprises a sliding member, sliding on the guiding slot, and a second ramped protrusion disposed on the sliding member and capable of moving with the sliding member to be selectively embedded between the first ramped protrusions; and
  - a shoulder strap, wherein the end of the shoulder strap passes



through the relief slot to be fixed on the sliding member.

4. The chair of claim 3, further comprising an infant insert, attached to the sliding member at a front side of the backrest.
5. A chair, comprising:
  - a backrest having a guiding slot and an inlet space communicating with the guiding slot;
  - an attachment component, fixedly disposed on the backrest;
  - an adjustment component, disposed on the attachment component and capable of being operated to move relative to the attachment component; and
  - a shoulder strap, an end of the shoulder strap being connected to the adjustment component;
  - a seat plate, the backrest being disposed above the seat plate;
  - a recliner mechanism, for constraining the backrest to be disposed at a slanted angle relative to the seat plate;
  - a single-structured handle, connected to the recliner mechanism and passing through and sliding on the guiding slot, the single-structured handle having a handle body and a retaining portion, disposed to be connected with each other at two sides of the guiding slot, a profile of the inlet space being larger than a profile of the retaining portion; and
  - a resilient member, connected to the handle body and the backrest and capable of being resiliently deformed by moving the single-structured handle along the guiding slot.
6. The chair of claim 5, wherein the resilient member is molded together with the single-structured handle.
7. The chair of claim 5, wherein the resilient member is bar-shaped or ring-shaped.
8. The chair of claim 5, further comprising a one-time snap, disposed at the inlet space, obstructing the retaining portion from getting

into the inlet space.

Amendments to the claims have been filed as follows.

Claims

What is claimed is:

1. An adjustable harness, installed on a chair, the adjustable harness comprising:
  - an attachment component comprising a guiding slot, a relief slot extending parallel to the guiding slot, and a plurality of first ramped protrusions, fixedly disposed on a backrest of the chair;
  - an adjustment component disposed on the attachment component and capable of being operated to move relative to the attachment component, wherein the adjustment component comprises a sliding member, sliding on the guiding slot, and a second ramped protrusion disposed on the sliding member to be selectively embedded between the first ramped protrusions; and
  - a shoulder strap, wherein the end of the shoulder strap passes through the relief slot to be fixed on the sliding member.
2. The adjustable harness of claim 1, further comprising an infant insert, attached to the sliding member from a front side of the backrest.
3. A chair, comprising:
  - a backrest;
  - an attachment component comprising a guiding slot, a relief slot extending parallel to the guiding slot, and a plurality of first ramped protrusions, disposed fixedly on the backrest;

11 11 14

an adjustment component disposed on the attachment component and capable of being operated to move relative to the attachment component, wherein the adjustment component comprises a sliding member, sliding on the guiding slot, and a second ramped protrusion disposed on the sliding member and capable of moving with the sliding member to be selectively embedded between the first ramped protrusions; and

a shoulder strap, wherein the end of the shoulder strap passes through the relief slot to be fixed on the sliding member.

4. The chair of claim 3, further comprising an infant insert, attached to the sliding member at a front side of the backrest.

5. The chair of claim 3, wherein the backrest has a guiding slot and an inlet space communicating with the guiding slot, the chair further comprising:

a seat plate, the backrest being disposed above the seat plate;

a recliner mechanism, for constraining the backrest to be disposed at a slanted angle relative to the seat plate;

a single-structured handle, connected to the recliner mechanism and passing through and sliding on the backrest guiding slot, the single-structured handle having a handle body and a retaining portion, disposed to be connected with each other at two sides of the guiding slot, a profile of the inlet space being larger than a profile of the retaining portion; and

a resilient member, connected to the handle body and the backrest and capable of being resiliently deformed by moving the single-structured handle along the backrest guiding slot.

6. The chair of claim 5, wherein the resilient member is molded together with the single-structured handle.
7. The chair of claim 5, wherein the resilient member is bar-shaped or ring-shaped.
8. The chair of claim 5, further comprising a one-time snap, disposed at the inlet space, obstructing the retaining portion from getting into the inlet space.



**Application No:** GB1402136.4

**Examiner:** Mr David McWhirter

**Claims searched:** 1-4

**Date of search:** 25 July 2014

**Patents Act 1977: Search Report under Section 17**

**Documents considered to be relevant:**

Category	Relevant to claims	Identity of document and passage or figure of particular relevance
A	None	US 6398302 B1 (FREEDMAN ET AL.)
A	None	US 6155638 A (BAPST)

**Categories:**

X	Document indicating lack of novelty or inventive step	A	Document indicating technological background and/or state of the art.
Y	Document indicating lack of inventive step if combined with one or more other documents of same category.	P	Document published on or after the declared priority date but before the filing date of this invention.
&	Member of the same patent family	E	Patent document published on or after, but with priority date earlier than, the filing date of this application.

**Field of Search:**

Search of GB, EP, WO & US patent documents classified in the following areas of the UKC<sup>X</sup> :

Worldwide search of patent documents classified in the following areas of the IPC

A47D; B60N; B62B

The following online and other databases have been used in the preparation of this search report

EPODOC, WPI

**International Classification:**

Subclass	Subgroup	Valid From
None		