



US00D678372S

(12) **United States Design Patent**  
**Trussell**

(10) **Patent No.:** **US D678,372 S**

(45) **Date of Patent:** **\*\* Mar. 19, 2013**

(54) **WELDING JIG**

(71) Applicant: **Christopher Bryan Trussell**,  
Edgewood, TX (US)

(72) Inventor: **Christopher Bryan Trussell**,  
Edgewood, TX (US)

(\*\*) Term: **14 Years**

(21) Appl. No.: **29/436,300**

(22) Filed: **Nov. 2, 2012**

(51) **LOC (9) Cl.** ..... **15-09**

(52) **U.S. Cl.** ..... **D15/144**

(58) **Field of Classification Search** ..... D8/71;  
D15/140, 141, 144, 144.1, 144.2; D25/122;  
29/272, 282, 281.1, 402, 728, 784, 795, 869;  
72/52, 284; 156/304.6; 219/87, 91.2, 103,  
219/121.63, 124.34, 161, 242, 521, 524,  
219/535; 228/6.1, 17, 17.5, 32, 44.3, 44.7,  
228/45, 47.1, 49.2, 49.3, 49.6, 119, 165,  
228/169, 170, 173.8, 189; 269/41, 42, 43,  
269/70, 71, 73, 132, 266; 285/24, 27, 41

See application file for complete search history.

(56) **References Cited**

U.S. PATENT DOCUMENTS

1,071,289	A *	8/1913	Bader	.....	269/269
4,516,308	A	5/1985	Urban		
4,541,621	A	9/1985	Amos		
5,082,037	A	1/1992	Hammons et al.		
5,124,533	A *	6/1992	Dommer et al.	.....	219/243
5,385,280	A	1/1995	Littlepage et al.		
D365,114	S *	12/1995	Walker	.....	D15/140
5,660,317	A *	8/1997	Singer et al.	.....	228/44.3
5,732,455	A *	3/1998	Diede	.....	29/281.5

6,511,088	B2	1/2003	Kahlstorf		
6,638,130	B2 *	10/2003	Wilbur, Jr.	.....	445/30
6,648,318	B1 *	11/2003	Oetlinger et al.	.....	269/41
6,765,173	B2 *	7/2004	Suzuki	.....	219/121.63
6,860,475	B2 *	3/2005	Wong	.....	269/41
7,172,105	B2	2/2007	Maes		
7,367,487	B2 *	5/2008	Murakawa et al.	.....	228/112.1
7,398,965	B2 *	7/2008	Glaser et al.	.....	269/71
2002/0008364	A1	1/2002	Kahlstorf		
2005/0092213	A1	5/2005	Wilson et al.		
2005/0218189	A1	10/2005	Maes		
2006/0151572	A1 *	7/2006	Yamaoka et al.	.....	228/47.1
2008/0231029	A1	9/2008	Hummel		
2012/0248071	A1 *	10/2012	Ikoma	.....	219/104

OTHER PUBLICATIONS

Javelin Industrial, Portable Fabrication Station, Internet website, copyright 2012, date of publication unknown.

\* cited by examiner

Primary Examiner — Patricia Palasik

(74) Attorney, Agent, or Firm — Michael D. Volk, Jr.

(57) **CLAIM**

The ornamental design for a welding jig, as shown.

**DESCRIPTION**

FIG. 1 is a perspective view of a welding jig showing my new design;

FIG. 2 is a front view thereof;

FIG. 3 is a back view thereof;

FIG. 4 is a right side view thereof;

FIG. 5 is a left side view thereof;

FIG. 6 is a top view thereof; and,

FIG. 7 is a bottom view thereof.

**1 Claim, 6 Drawing Sheets**

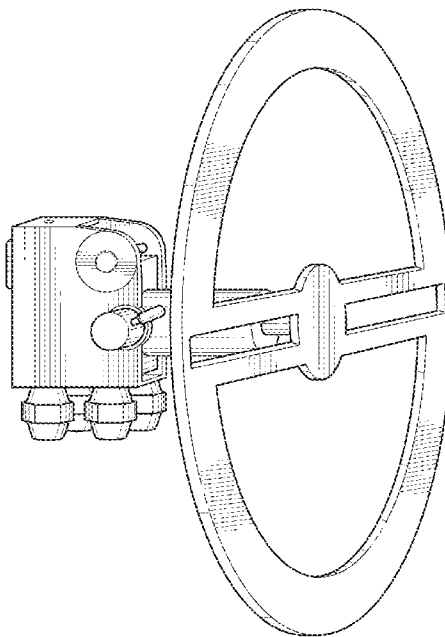

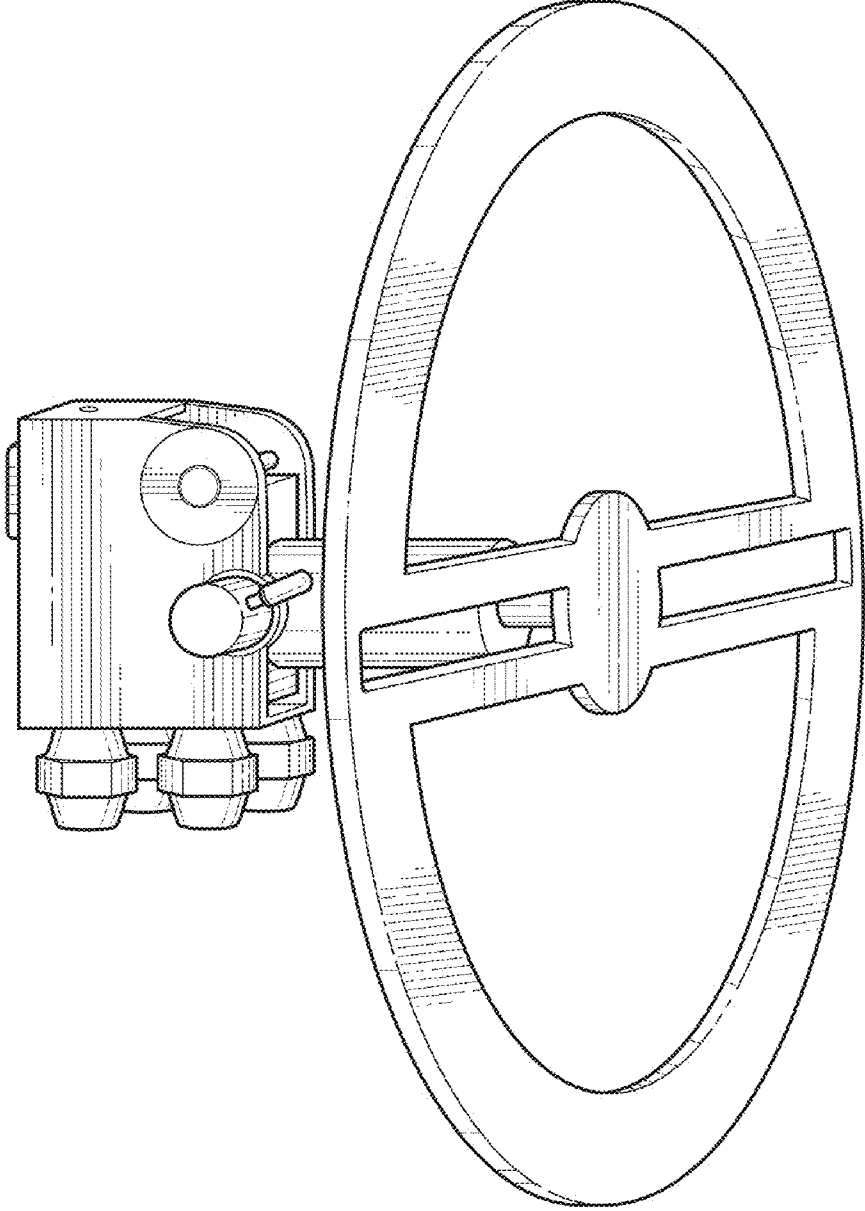

**FIG. 1**

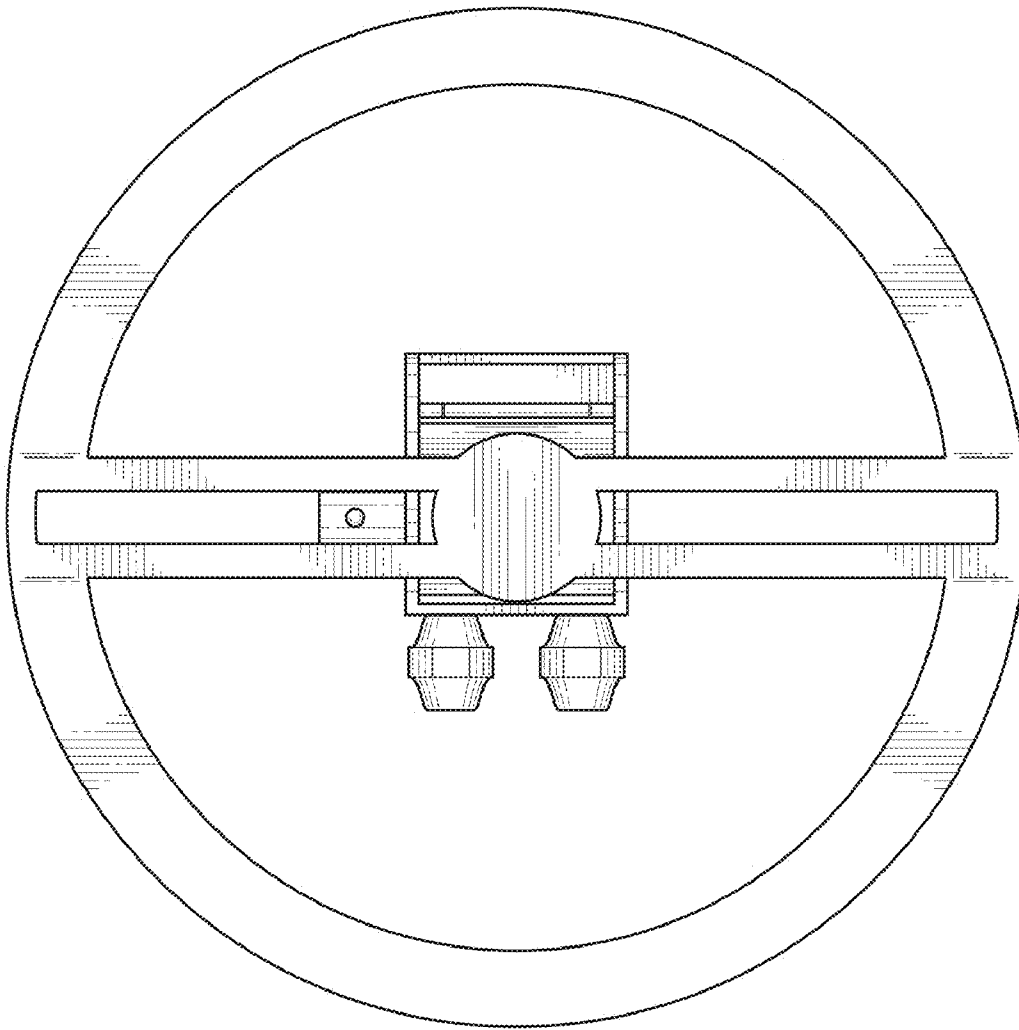

FIG. 2

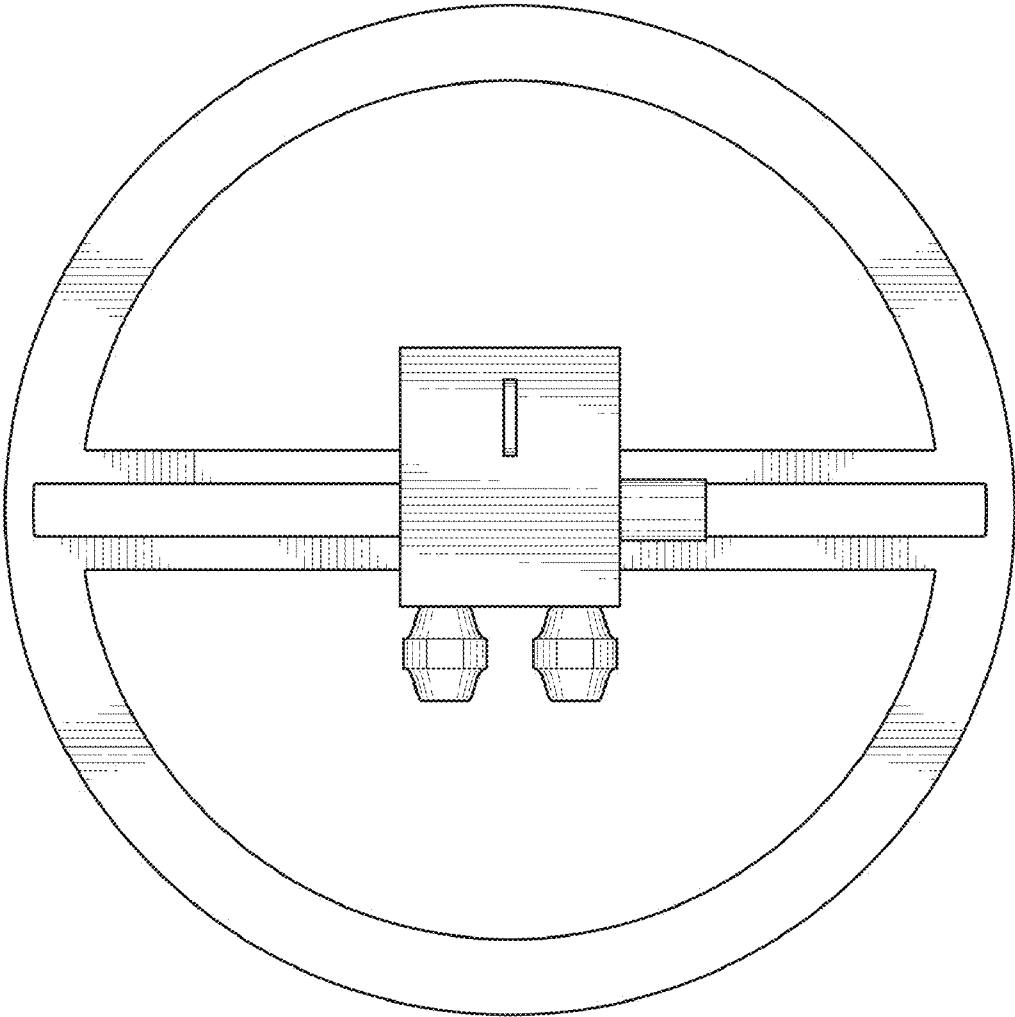

FIG. 3

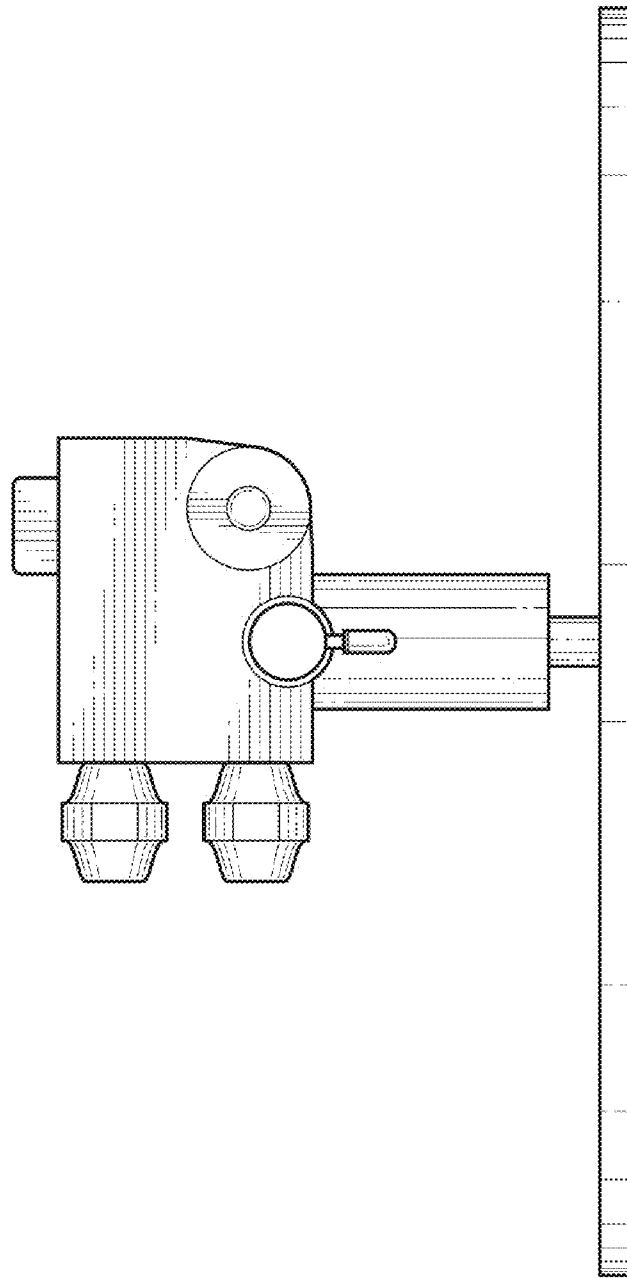
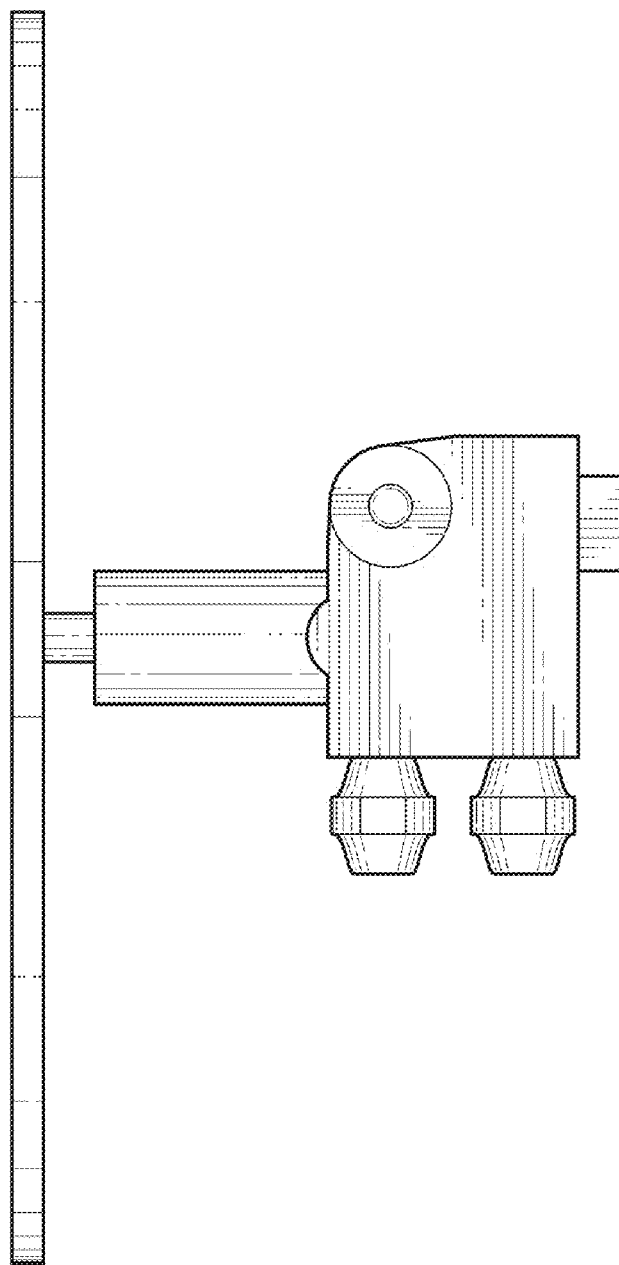
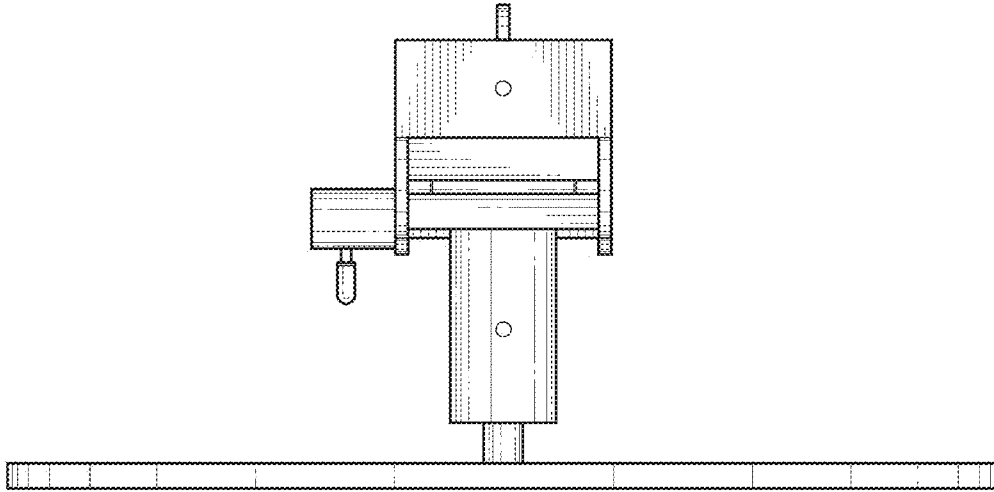

FIG. 4



**FIG. 5**



**FIG. 6**

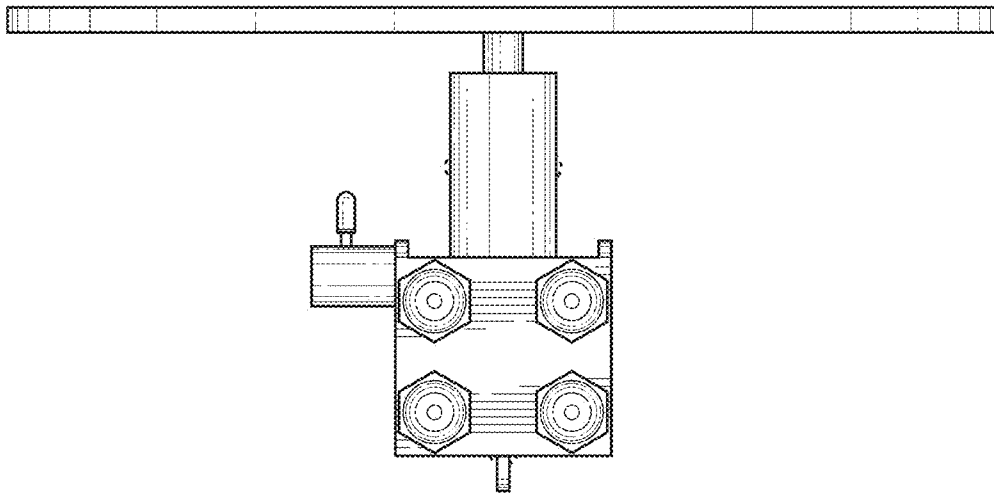

**FIG. 7**