

(PRIOR ART)

Fig. 2A

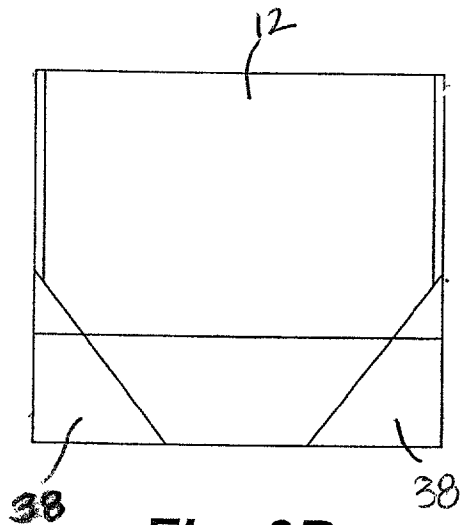

Fig. 2B

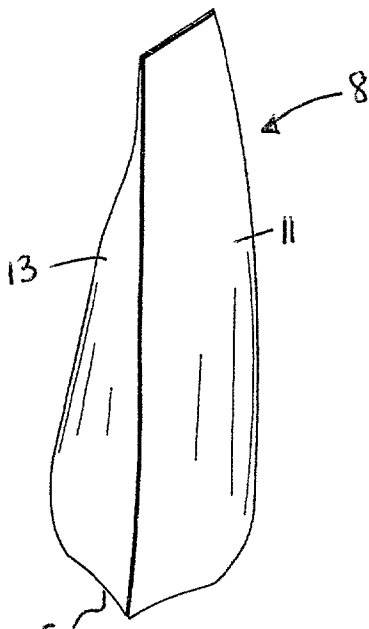

Fig. 3A

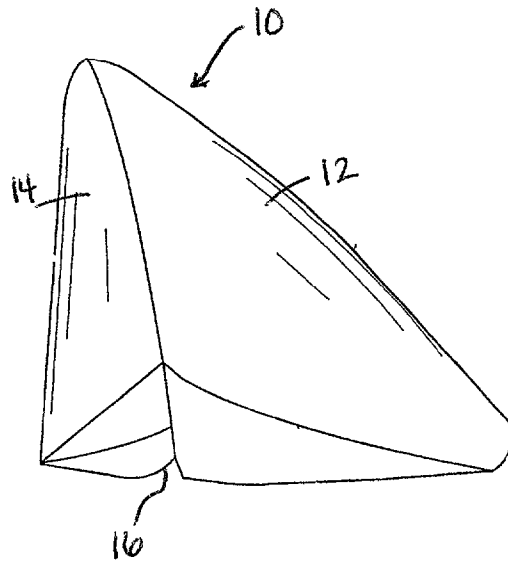

Fig. 3B

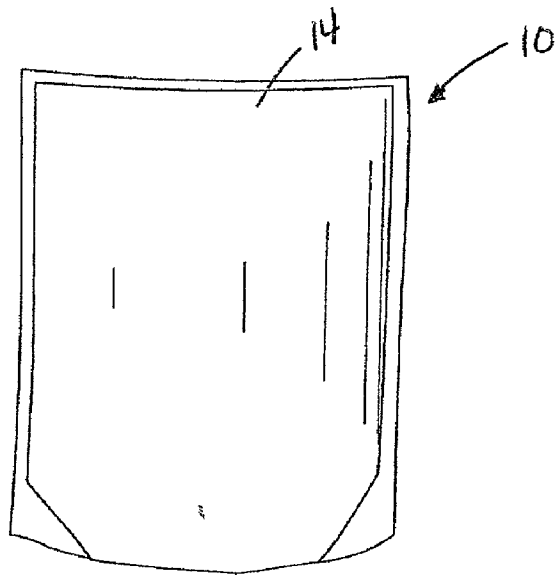

Fig. 4A

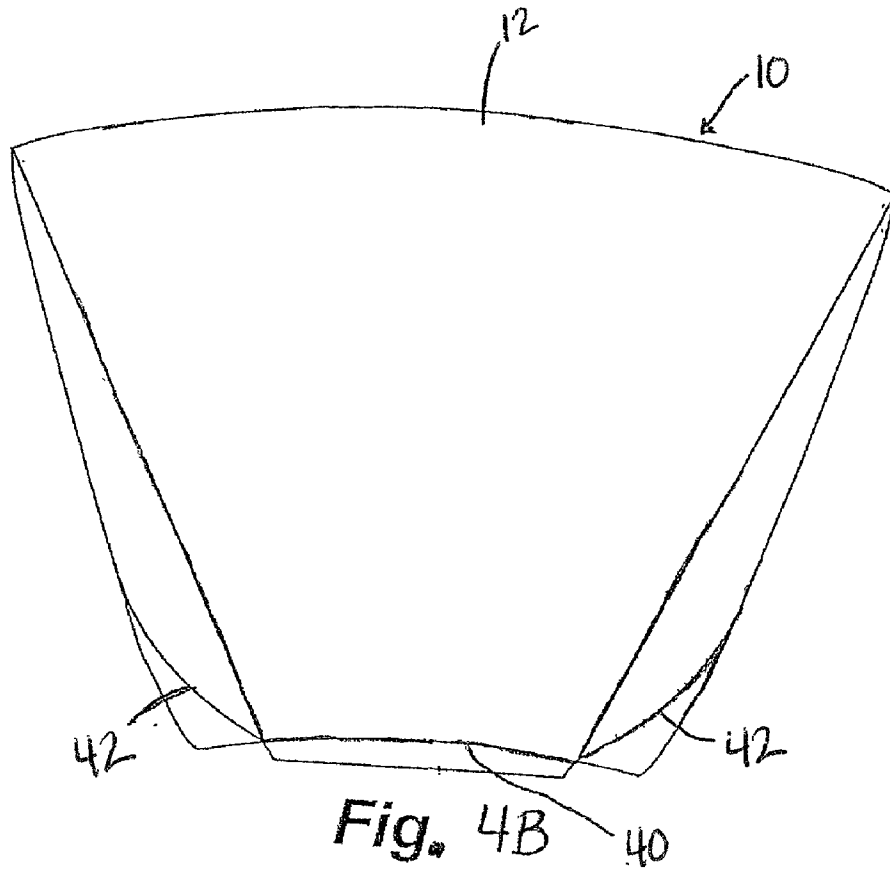

Fig. 4B

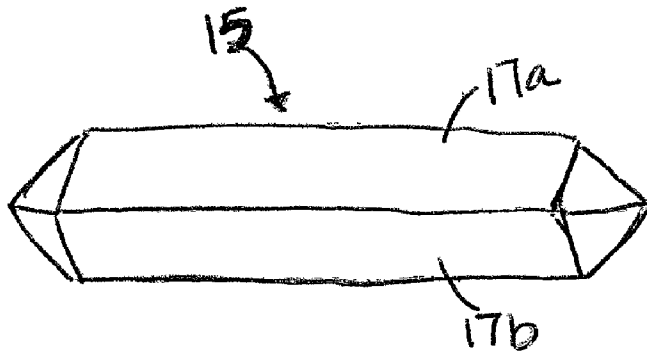

Fig. 5A

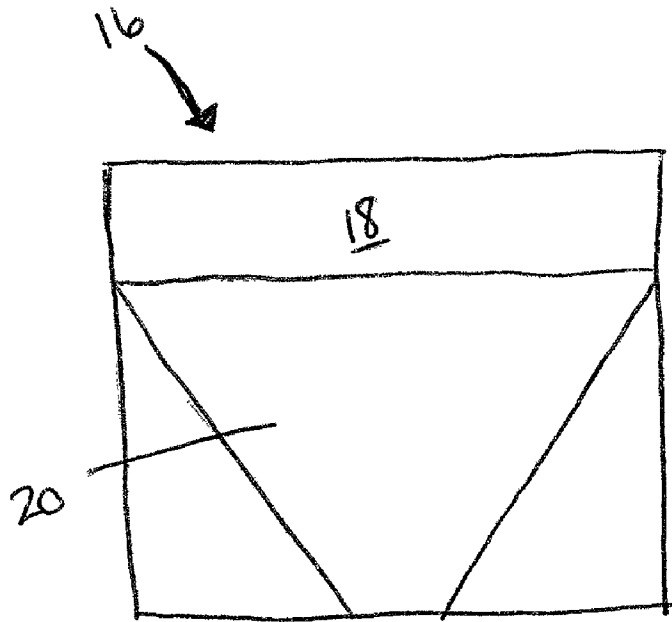
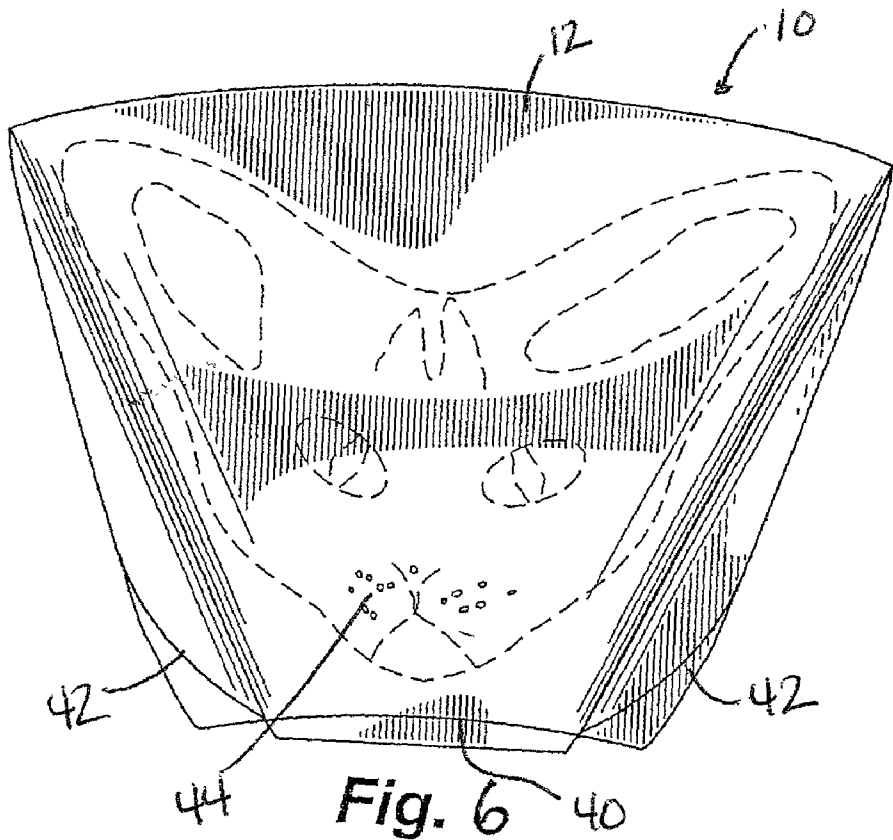

Fig. 5B



STANDUP FLEXIBLE POUCH AND METHOD FOR MAKING A STANDUP FLEXIBLE POUCH

FIELD OF THE INVENTION

[0001] The present invention relates to the packaging industry, and more particularly to a standup flexible pouch and a method for making a standup flexible pouch.

BACKGROUND OF THE INVENTION

[0002] Metal cans and glass and plastic bottles have traditionally been used to package liquid and solid food products. More recently, in an effort to overcome problems associated with these types of packaging, flexible packaging material has been used. The flexible material is less expensive, provides for a lighter package, and the packages take up less space when empty than metal, glass, or rigid plastic containers.

[0003] However, the early flexible containers were also problematic. These containers were produced from relatively thick, expensive material that was unstable when placed on a store shelf, and therefore required support. Further, the means of producing these flexible containers resulted in structural weaknesses along the bottom portion of the container, as well as interior crevices in the bottoms and corners that acted as bacterial traps. The methods employed to produce these containers were complicated, requiring several welding steps, which often had to be performed with the container in the vertical position.

[0004] In order to overcome these problems, flexible containers were developed using a single sheet of flexible material, folded in such a manner so as to result in a container that, when filled, stands upright without additional support, such as those found in U.S. Pat. Nos. 5,135,464 and 5,273,362. These containers are more lightweight and less expensive to produce than containers made from metal, glass, or rigid plastic materials.

[0005] It is often desirable, however, in order to better attract consumers to products and to provide a more aesthetically pleasing container, to produce flexible containers of various alternative shapes. In particular, it is desirable to produce flexible containers of alternative shapes that are still inexpensive to produce and that are still capable of standing upright on the store shelf. One example is a pouch shaped like a skull that can be pre-printed with the face of a particular character. Previous methods used to produce standup flexible pouches of alternative shapes have required alterations to be made to the amount of material used to make the pouch, as well as having to die cut the material, which is very expensive. This in turn resulted in a reduction in the rate at which the pouches are constructed and filled with the product. Therefore, it is also desirable to be able to produce these pouches using the same machinery with little to no modifications and the same or nearly the same amount of flexible material as that used to produce the symmetrical, standard pouches, and to be able to fill these pouches at the same rate as the symmetrical pouches.

[0006] Therefore, what is needed in the art is a standup flexible pouch having an asymmetrical shape, such as a shape that resembles a skull, that can be fabricated in the same manner as known, symmetrical standup flexible pouches using the same or nearly the same amount of

flexible material and with little to no modification to the machinery, and that can be filled with product at the same rate as known, symmetrical standup flexible pouches.

SUMMARY OF THE INVENTION

[0007] The present invention satisfies the need described above by providing a standup, flexible pouch comprising a gusset that has a back gusset panel and a front gusset panel, the front gusset panel and back gusset panel being connected to one another and the front gusset panel being larger than the back gusset panel. The width of the front gusset panel and the width of the back gusset panel together equal the gusset width. Further, the standup flexible pouch comprises a back wall and a front wall, the back gusset panel being attached to the lower portion of the back wall, and the front gusset panel of the gusset being attached to the lower portion of the front wall. In addition, the back wall, the front wall, and the gusset are made of a flexible sheet of material.

[0008] The difference between the width of the front gusset panel and the width of the back gusset panel is known as the offset. Stated differently, when the standup flexible pouch of the present invention is unfilled and flattened, the front gusset panel and the back gusset panel are flattened against one another. The portion of the front gusset panel that extends beyond the back gusset panel, and therefore is not flattened against a corresponding portion of the back gusset panel, is the offset. The offset of the front gusset panel from the back gusset panel can range from between about 1% to about 99% of the gusset width. By comparison, when a symmetrical standup pouch disclosed by the prior art is unfilled and flattened, there is no offset.

[0009] In one embodiment of the present invention, the back wall, front wall and gusset are integrally connected end-to-end and are formed from a continuous sheet of flexible material. The pouch resembles a skull as a result of the offset, which causes the front wall to be longer than the back wall, and the front wall and the front gusset panel to protrude outwardly from the back wall and the back gusset panel when the flexible material is folded. The difference in length between the front wall and the back wall is directly proportional to the offset. The skull shape is further achieved by heat sealing a portion of the front gusset panel of the gusset to a portion of the front wall, forming an angular jaw line. In particular, the lower portion of the front wall is sealed to the front gusset panel across opposing gusset seal regions to form opposing gusset seal flaps. The opposing gusset seal flaps can then be removed from the pouch, or they can be used to add another dimension to the pouch. For example, the opposing gusset seal flaps can be cut so as to resemble cat whiskers, or they can serve as the location for proof-of-purchase symbols or other collectible features. The opposing gusset seal flaps can also be heat-sealed so as to curl underneath the pouch.

[0010] Accordingly, the standup flexible pouch of the present invention can be made using the same amount of material as a conventional standup flexible pouch with only a slight reduction in the volume of the pouch, as compared to the volume of the conventional pouch. In the alternative, a small amount of additional material can be used to make a standup flexible pouch of the present invention that has the same volume as a conventional standup flexible pouch.

[0011] According to another aspect of this invention, a method for forming a standup flexible pouch comprises the

steps of providing the sheet of flexible material described above, folding the sheet of flexible material to form a back wall, a front wall, and a gusset, the gusset comprising a back gusset panel and a front gusset panel that is larger than the back gusset panel, and sealing portions of the front wall, back wall and gusset together such that the upper portion of the front wall is connected to the upper portion of the back wall, the back gusset panel is attached to the lower portion of the back wall, and the front gusset panel is attached to the lower portion of the front wall.

[0012] In one embodiment of the invention, the front gusset panel of the gusset and the lower portion of the front wall are sealed together across first opposing gusset seal regions, and the back gusset panel of the gusset and the lower portion of the back wall are sealed to one another across second opposing gusset seal regions, the first opposing gusset seal regions being larger than the second opposing gusset seal regions. The opposing gusset seal regions can take a variety of shapes that are known in the packaging industry, including miter, elliptical, parabolic, and doyne. The shape chosen for the opposing gusset seal regions will determine the shape of the jaw line of the filled standup flexible pouch. According to a particular embodiment of the present invention, the first opposing gusset seal regions and the second opposing gusset seal regions are mitered. The difference in the width of the front gusset panel and the width of the back gusset panel is the offset, and the difference in length between the front wall and the back wall is approximately directly proportional to the offset. However, it is understood that, in the machinery process, it is common for the front wall to be slightly longer than the back wall so as to ensure that contents of the pouch will not be revealed to the consumer. Further, in a preferred embodiment of the present invention, the relationship of the gusset width to the pouch height is approximately in the range of one-to-one, and the relationship of the pouch width to the gusset width is approximately two-to-one.

[0013] The actual dimensions of the standup flexible pouch can be varied in order to achieve the desired skull shape; for example, increasing the offset will result in the standup flexible pouch having a more pointed chin. Varying the relationship of the gusset width to the pouch height and the relationship of the gusset width to the pouch width can also serve to vary the dimensions of the standup flexible pouch so as to achieve the desired result. Accordingly, the desired shape of the standup flexible pouch is achieved with only minor modifications to the machinery and the material used to make known, symmetrical standup flexible pouches.

[0014] The standup flexible pouch of the present invention is desirably made of a flexible packaging material. Particularly suitable packaging materials include paper, foil, polyester, polypropylene, nylon, vinyl, and polyethylene, as well as combinations thereof. According to a preferred embodiment of the present invention, a polyester polyethylene lamination is used.

[0015] Accordingly, an object of the present invention is to provide a standup flexible pouch having an asymmetrical shape that can be formed from a piece of material only slightly different in size from a piece of material used to form known standup flexible pouches having the same volume.

[0016] Another, object of the present invention is to provide a standup flexible pouch having an asymmetrical shape

that can be formed from the same piece of material used to form known standup flexible pouches with only a slight reduction in volume as compared to known standup flexible pouches.

[0017] Another object of the present invention is to provide a standup flexible pouch having an asymmetrical shape that can be formed using the same machinery used to form known standup flexible pouches, with only minor modifications to the machinery being required.

[0018] Yet another object of the present invention is to provide a standup flexible pouch having an asymmetrical shape that can be filled with product at the same rate and the same amount of product as known standup flexible pouches.

[0019] Still another object of the present invention is to provide a standup flexible pouch have a shape resembling a skull and that can be printed with the face of a character so as to be more attracting to consumers.

[0020] Still another object of the present invention is to provide an inexpensive method of producing a standup flexible pouch having an asymmetrical shape.

[0021] Still another object of the present invention is to provide a method of producing a standup flexible pouch having an asymmetrical shape using the same machinery as that used to produce conventional standup flexible pouches, with only minor modifications to the machinery being required.

[0022] Still another an object of the present invention is to provide a method of producing a standup flexible pouch having an asymmetrical shape that can be formed from a piece of material only slightly different in size from a piece of material used to form known standup flexible pouches having the same volume.

[0023] Still another object of the present invention is to provide a method of producing a standup flexible pouch having an asymmetrical shape that can be formed from the same piece of material used to form known standup flexible pouches with only a slight reduction in volume as compared to known standup flexible pouches.

[0024] Still another object of the present invention is to provide a method of producing a standup flexible pouch having an asymmetrical shape that can be filled with product at the same rate as conventional standup flexible pouches.

[0025] Other objects, features and advantages of this invention will be appreciated by those skilled in the art from the following detailed description, drawings and claims.

DETAILED DESCRIPTION OF THE FIGURES

[0026] FIG. 1a is a top view of the sheet of flexible material used to make a standup flexible pouch according to methods disclosed by the prior art.

[0027] FIG. 1b is a top view of a sheet of flexible material used to make a standup flexible pouch according to an embodiment of the present invention.

[0028] FIG. 2a is a front view of a flat, unfilled standup flexible pouch disclosed by the prior art.

[0029] FIG. 2b is a front view of a flat, unfilled standup flexible pouch made according to an embodiment of the present invention.

[0030] FIG. 3a is a side view of a filled standup flexible pouch disclosed by the prior art.

[0031] FIG. 3b is a side view of a filled standup flexible pouch made according to an embodiment of the present invention.

[0032] FIG. 4a is a rear view of a standup flexible pouch made according to an embodiment of the present invention.

[0033] FIG. 4b is a front view of a standup flexible pouch made according to an embodiment of the present invention.

[0034] FIG. 5a is a bottom view of a standup flexible pouch disclosed by the prior art.

[0035] FIG. 5b is a bottom view of standup flexible pouch made according to an embodiment of the present invention.

[0036] FIG. 6 is a front view of a standup flexible pouch having a front wall that has been decorated with a printed design according to an embodiment of the present invention.

DETAILED DESCRIPTION OF THE INVENTION

[0037] As summarized above, the present invention encompasses a standup, flexible pouch having an asymmetrical shape, and a method for making such a standup flexible pouch. The structure of a standup flexible pouch made according to an embodiment of the present invention is described below, followed by a description of a method for making the standup flexible pouch.

[0038] FIG. 3A illustrates a filled standup flexible pouch 8 disclosed by the prior art. The pouch 8 has a front wall 11, a back wall 13, and a gusset 15. As illustrated in FIG. 5A, the gusset 15 of the prior art pouch 8 is comprised of two equal sized panels 17a and 17b.

[0039] By comparison, FIG. 3B illustrates a filled standup flexible pouch 10 according to an embodiment of the present invention. The pouch 10 has a front wall 12, a back wall 14, and a gusset 16. As illustrated in FIG. 5B, the gusset 16 is comprised of a back gusset panel 18 and a front gusset panel 20, the back gusset panel 18 being connected to the lower portion 22 of the back wall 14, and the front gusset panel 20 being connected to the lower portion 24 of the front wall 12. The upper portion 26 of the back wall 14 is connected to the upper portion 28 of the front wall 12.

[0040] FIG. 1A illustrates a continuous sheet of flexible material 29 that can be used to make a standup flexible pouch 8 disclosed by the prior art. By comparison, FIG. 1B illustrates a continuous sheet of flexible material 30 that can be used to make a standup flexible pouch 10 according to an embodiment of the present invention. Fold line 32a delineates a boundary between the front wall 12 and the front gusset panel 20 and bisects the first opposing gusset seal regions 34a and 34b; fold line 32b delineates a boundary between the front gusset panel 20 and the back gusset panel 18; and fold line 32c delineates a boundary between the back gusset panel 18 and the lower portion 22 of the back wall 14 and bisects the second opposing gusset seal regions 36a and 36b.

[0041] The first opposing gusset seal regions 34a and 34b and the second opposing gusset seal regions 36a and 36b can take a variety of shapes that are known in the packaging industry, including miter, elliptical, parabolic, and doyne.

The shape chosen for the first opposing gusset seal regions 34a and 34b and the second opposing gusset seal regions 36a and 36b will determine the shape of the jaw line of the filled standup flexible pouch. According to a particular embodiment of the present invention, the first opposing gusset seal regions 34a and 34b and the second opposing gusset seal regions 36a and 36b are both mitered.

[0042] As shown by FIG. 1A, the prior art discloses a continuous sheet of flexible material having, fold lines 31a, 31b and 31c, all of which are equidistant from one another. However, according to one embodiment of the present invention, fold line 32a is located at a distance from fold line 32b that is greater than the distance between fold line 32b and fold line 32c so as to produce an asymmetrical standup flexible pouch. The distance between fold lines 32a and 32b is the width of the front gusset panel 20, and the distance between fold lines 32b and 32c is the width of the back gusset panel 18. The difference between the width of the front gusset panel 20 and the width of the back gusset panel 18 is the offset of the front gusset panel 20 from the back gusset panel 18. The distance between fold lines 32a and 32c is the gusset 16 width. Further, according to one embodiment of the present invention, the difference in length between the front wall 12 and the back wall 14 is approximately directly proportional to the offset. The farther the front wall 12 is desired to protrude from the back wall 14, the larger the offset will be. The offset can further be described as the portion of the front gusset panel 20 that is not flattened against a corresponding portion of the back gusset panel 18 when the pouch 10 is unfilled and flattened. For example, if the back gusset panel has a width of four inches, and the front gusset panel has width of 8 inches, the offset is four inches. The offset can range from about 1% the gusset 16 width to about 99% the gusset 16 width, depending on the desired shape of the standup flexible pouch 10. In the example stated above, the offset is four inches, and the gusset 16 width is twelve inches, so the offset is 33% the gusset 16 width. According to a preferred embodiment of the present invention, the offset ranges between about 10% the gusset 16 width to about 80% the gusset 16 width. In a more preferred embodiment of the invention, the offset ranges between about 20% the gusset 16 width to about 60% the gusset 16 width.

[0043] Further, according to one embodiment of the present invention, the relationship of the gusset 16 width to the pouch 10 height is a ratio between about 100:1 and about 1:100, and the relationship of the pouch 10 width to the gusset 16 width is a ratio between about 100:1 to about 1:10. In a preferred embodiment of the present invention, the relationship of the gusset 16 width to the pouch 10 height is a ratio between about 10:1 and about 1:10, and the relationship of the pouch 10 width to the gusset 16 width is a ratio between about 10:1 to about 1.1: 1. In a more preferred embodiment, the relationship of the gusset 16 width to the pouch 10 height is a ratio of approximately 1:1, and the relationship of the pouch 10 width to the gusset 16 width is a ratio of approximately 2:1.

[0044] As shown in FIG. 1A, the prior art discloses a continuous sheet of flexible material having two sets of opposing gusset seal regions 33a, 33b, 33c and 33d, all of which are equal in area to one another. By comparison, the area of the first opposing gusset seal regions 34a and 34b is larger than the area of the second opposing gusset seal

regions **36a** and **36b**. According to one embodiment of the present invention, the first opposing gusset seal regions **34a** and **34b** and the second opposing gusset seal regions **36a** and **36b** are both mitered. Fold line **32a** bisects the first opposing miter gusset seal regions **34a** and **34b**, and fold line **32c** bisects the second opposing miter gusset seal regions **36a** and **36b**. The ratio of the area of the first opposing miter gusset seal regions **34a** and **34b** to the area of the second opposing miter gusset seal regions **36a** and **36b** is directly proportional to the difference between the width of the front gusset panel **20** and the width of the back gusset panel **18**. A miter seal requires that the first opposing miter gusset seal regions **34a** and **34b** and the second opposing miter gusset seal regions **36a** and **36b** be right triangles having two 45 degree angles. As the vertical side of the first opposing miter gusset seal regions **34a** and **34b** is equal to the width of the front gusset panel **20**, the horizontal side of the first opposing miter gusset seal regions **34a** and **34b** must also be equal to the width of the front gusset panel **20** in order to achieve a right triangle having two 45 degree angles, the area of the first opposing miter gusset seal regions **34a** and **34b** is directly proportional to the width of the front gusset panel **20**. Likewise, the area of the second opposing miter gusset seal regions **36a** and **36b** is directly proportional to the width of the back gusset panel **18**.

[0045] As can be appreciated by those skilled in the art, the dimensions of the front wall **12**, the back wall **14**, the front gusset panel **20**, the back gusset panel **22**, the first opposing miter gusset seal regions **34a** and **34b**, and the second opposing miter gusset seal regions **36a** and **36b**, as well as the distance between fold lines **32a** and **32b** and the distance between fold lines **32b** and **32c**, can vary depending on the desired overall size of the pouch **10**.

[0046] The standup flexible pouch **10** is suitably made by using machinery known to those of skill in the art, such as that disclosed in U.S. Pat. No. 5,135,464, col.4, 1. 65 through col. 5, 1. 5. As will be understood by one of ordinary skill in the art, only the creaser bars and the reverse plow nose of the horizontal poucher need to be adjusted in order to achieve the desired offset of the front gusset panel from the back gusset panel, and thus to achieve the desired dimensions of the pouch **10**. The creaser bars and the reverse plow nose are adjusted using methods known to those of ordinary skill in the art. In a preferred method, the creaser bars and the reverse plow nose are moved off of the center line of the horizontal poucher in order to achieve the desired offset.

[0047] In one embodiment of the present invention, the continuous sheet **30** is folded along fold lines **32a**, **32b** and **32c**; the lower portion **24** of the front wall **12** is sealed to the front gusset panel **20**; the lower portion **22** of the back wall **14** is sealed to the back gusset panel **18**; and the upper portion **28** of the front wall **12** is sealed to the upper portion **22** of the back wall **14**. In particular, the lower portion **24** of the front wall **12** is peripherally heat-sealed to the front gusset panel **20**; the lower portion **22** of the back **14** is peripherally heat-sealed to the back gusset panel **18**; and the upper portion **28** of the front wall **12** is peripherally heat-sealed to the upper portion **22** of the back wall **14** using methods known to those of skill in the art, such as the method disclosed in U.S. Pat. No. 5,273,362, col. 10, 11. 5-21.

[0048] According to one embodiment of the invention, when the continuous sheet **30** is folded along fold line **32a**, the first opposing gusset seal regions **34a** and **34b** are folded in half. When the pouch is formed, the two halves of the gusset seal region **34a** are sealed together, as are the two halves of the gusset seal region **34b**, forming the opposing gusset seal flaps **38**. The opposing gusset seal flaps **38** can then be cut off of the pouch and discarded without affecting the integrity of the pouch **10**. The opposing gusset seal flaps **38** can also be used to add additional dimension to the pouch **10**, such as by cutting the opposing gusset seal flaps **38** so as to resemble whiskers. The opposing gusset seal flaps **38** can also be used as a location for proof-of-purchase or other symbols. Alternatively, the opposing gusset seal flaps **38** can be heat-sealed at a higher temperature on the top side of the opposing gusset seal flaps **38** than on the bottom side of the opposing gusset seal flaps **38**, which will cause the opposing gusset seal flaps **38** to curl underneath the pouch **10**.

[0049] Once the pouch **10** is formed, it may be filled with product and sealed. This procedure may be performed according to methods known to those of skill in the art, such as that as disclosed in U.S. Pat. No. 5,135,464, col. 8, 11. 6-19. In one embodiment of the present invention, the pouch **10** is filled with a food product, such as a breakfast cereal.

[0050] As can be seen in FIG. 3B, the front wall **12** is longer than the back wall **14**, such that, when filled with product, the front wall **12** protrudes outwardly from the back wall **14** and forms a chin **40** and jaws **42**, resembling a skull. This is particularly true when the front wall **12** has been printed with the face of a character **44**, as can be seen in FIG. 6.

[0051] FIGS. 2A and 2B illustrate the difference in appearance between the frontal appearance of a flat, unfilled standup flexible pouch **8** disclosed by the prior art and a flat, unfilled standup flexible pouch **10** disclosed in one embodiment of the present invention. FIGS. 4A and 4B illustrate the difference in appearance between the front wall **12** and the back wall **14** of the pouch **10** disclosed in one embodiment of the present invention.

[0052] It should be understood that the foregoing relates to particular embodiments of the present invention, and that numerous changes may be made therein without departing from the scope of the invention as defined by the following claims.

I claim:

1. A standup flexible pouch, comprising
 - a back wall;
 - a front wall longer than the back wall and having an upper portion connected to an upper portion of the back wall; and
 - a gusset connecting a lower portion of the back wall to a lower portion of the front wall, the gusset comprising a back gusset panel and a front gusset panel connected to the back gusset panel, the back gusset panel attached to the lower portion of the back wall, the front gusset panel attached to the lower portion of the front wall, the front gusset panel being offset from the back gusset panel, and the back wall, the front wall, and the gusset made of flexible sheet material.

2. A standup flexible pouch as in claim 1 wherein the back wall, the front wall and the gusset are integrally connected end-to-end and are formed from a continuous sheet of flexible packaging material.

3. A standup flexible pouch as in claim 2 wherein the continuous sheet of flexible packaging material is selected from the group consisting of paper, foil, polypropylene, nylon, vinyl, and polyethylene.

4. A standup flexible pouch as in claim 3 wherein the continuous sheet of flexible packaging material a polyester polyethylene lamination.

5. A standup flexible pouch as in claim 2 wherein the back wall, the front wall and the gusset are heat sealed to one another.

6. A standup flexible pouch as in claim 5 wherein the back wall, the front wall and the gusset are peripherally heat sealed to one another.

7. A standup flexible pouch as in claim 1 wherein the offset is between about 1% to about 99% the gusset width.

8. A standup flexible pouch as in claim 7 wherein the offset is between about 10% to about 80% the gusset width.

9. A standup flexible pouch as in claim 8 wherein the offset is between about 20% to about 60% the gusset width.

10. A standup flexible pouch as in claim 1 wherein the difference in length between the front wall and the back wall is approximately directly proportional to the offset, the relationship of the gusset width to the pouch height is a ratio between about 100:1 and about 1:100, and the relationship of the pouch width to the gusset width is a ratio between about 100:1 and about 1:10.

11. A standup flexible pouch as in claim 10 wherein the relationship of the gusset width to the pouch height is a ratio between about 10:1 and about 1:10.

12. A standup flexible pouch as in claim 11 wherein the relationship of the gusset width to the pouch height is 1:1.

13. A standup flexible pouch as in claim 10 wherein the relationship of the pouch width to the gusset width is a ratio between about 10:1 to about 1.1:1.

14. A standup flexible pouch as in claim 13 wherein the relationship of the pouch width to the gusset width is 2:1.

15. A standup flexible pouch as in claim 1 wherein the back wall, the front wall and the gusset are sealed to one another such that, when the pouch is filled with product, the front wall and the front gusset panel protrude outwardly from the back wall and form jaws, a chin and a face.

16. A standup flexible pouch as in claim 1 wherein the front wall is decorated with a printed design.

17. A standup flexible pouch as in claim 16 wherein the printed design is a face of a character.

18. A standup flexible pouch as in claim 1 wherein the front gusset panel and the front wall are sealed to one another across first opposing gusset seal regions and the back gusset panel and the back wall are sealed to one another across second opposing gusset seal regions, the first opposing gusset seal regions being larger than the second opposing gusset seal regions.

19. A standup flexible pouch as in claim 18 wherein the first opposing gusset regions are larger than the second opposing regions in direct proportion to the difference between the length of the front gusset panel and the back gusset panel.

20. A standup flexible pouch as in claim 18 wherein the first opposing gusset seal regions and the second opposing gusset seal regions have a shape selected from the group comprising elliptical, parabolic, doyne, and mitered.

21. A standup flexible pouch as in claim 20 wherein the first opposing gusset seal regions and the second opposing gusset seal regions have a mitered shape.

22. A standup flexible pouch as in claim 18 wherein the front gusset panel and the front wall are sealed to one another across first opposing gusset seal regions to form opposing gusset seal flaps.

23. A standup flexible pouch as in claim 22 wherein the opposing gusset seal flaps are cut to resemble animal whiskers.

24. A standup flexible pouch as in claim 22 wherein the opposing gusset seal flaps are heat sealed so as to curl the opposing gusset seal flaps underneath the standup flexible pouch.

25. A method of making a standup flexible pouch, comprising the steps of:

providing a sheet of flexible material having a length and a width;

folding the sheet of flexible material so as to form a back wall having an upper portion and a lower portion, a front wall longer than the back wall and having an upper portion and a lower portion, and a gusset connecting a lower portion of the back wall to the lower portion of the front wall, the gusset comprising a back gusset panel and a front gusset panel connected to the back gusset panel, the back gusset panel attached to the lower portion of the back wall, the front gusset panel attached to the lower portion of the front wall, and the front gusset panel being offset from the back gusset panel; and

sealing portions of the front wall, back wall and gusset together such that the upper portion of the front wall is connected to the upper portion of the back wall, the back gusset panel is attached to the lower portion of the back wall, and the front gusset panel is attached to the lower portion of the front wall.

26. A method as in claim 25 wherein the sheet of flexible material is selected from the group consisting of paper, foil, polyester, polypropylene, nylon, vinyl, and polyethylene.

27. A method as in claim 26 wherein the sheet of flexible material is a polyester polyethylene lamination.

28. A method as in claim 25 wherein the step of sealing includes heat sealing the back wall, the front wall and the gusset to one another.

29. A method as in claim 25 wherein the offset is between about 1% to about 99% the gusset width.

30. A method as in claim 29 wherein the offset is between about 10% to about 80% the gusset width.

31. A method as in claim 30 wherein the offset is between about 20% to about 60% the gusset width.

32. A method as in claim 25 wherein the difference in length between the front wall and the back wall is approximately directly proportional to the offset, A standup flexible pouch as in claim 1 wherein the difference in length between the front wall and the back wall is approximately directly proportional to the offset, the relationship of the gusset width to the pouch height is a ratio between about 100:1 and about 1:100, and the relationship of the pouch width to the gusset width is a ratio between about 100:1 and about 1:10.

33. A standup flexible pouch as in claim 32 wherein the relationship of the gusset width to the pouch height is a ratio between about 10:1 and about 1:10.

34. A standup flexible pouch as in claim 33 wherein the relationship of the gusset width to the pouch height is 1:1.

35. A standup flexible pouch as in claim 32 wherein the relationship of the pouch width to the gusset width is a ratio between about 10:1 to about 1.1:1.

36. A standup flexible pouch as in claim 35 wherein the relationship of the pouch width to the gusset width is 2:1.

37. A method as in claim 25 wherein the back wall, the front wall and the gusset are sealed to one another such that, when the pouch is filled with product, the front wall and the front gusset panel of the gusset protrude outwardly from the back wall and form jaws, a chin and a face.

38. A method as in claim 25 further comprising decorating the front gusset panel with a printed design.

39. A method as in claim 38 wherein the printed design is a face of a character.

40. A method as in claim 38 wherein the front gusset panel is decorated with a printed design prior to folding the sheet of flexible material.

41. A method as in claim 25 wherein the front gusset panel of the gusset and the front wall are sealed to one another across first opposing gusset seal regions and the back gusset panel of the gusset and the back wall are sealed to one another across second opposing gusset seal regions, the first opposing gusset seal regions being larger than the second opposing gusset seal regions.

42. A standup flexible pouch as in claim 41 wherein the first opposing gusset regions are larger than the second opposing regions in direct proportion to the difference between the length of the front gusset panel and the back gusset panel.

43. A standup flexible pouch as in claim 41 wherein the first opposing gusset seal regions and the second opposing gusset seal regions have a shape selected from the group comprising elliptical, parabolic, doyne, and mitered.

44. A standup flexible pouch as in claim 43 wherein the first opposing gusset seal regions and the second opposing gusset seal regions have a mitered shape.

45. A standup flexible pouch as in claim 41 wherein the front gusset panel and the front wall are sealed to one another across first opposing gusset seal regions to form opposing gusset seal flaps.

46. A standup flexible pouch as in claim 45 wherein the opposing gusset seal flaps are cut to resemble animal whiskers.

47. A standup flexible pouch as in claim 45 wherein the opposing gusset seal flaps are heat sealed so as to curl the opposing gusset seal flaps underneath the standup flexible pouch.

48. A method as in claim 25 wherein the folding step comprises folding the sheet of flexible polymer film along a first fold line, a second fold lines and a third fold line each extending across the width of the flexible sheet and spaced from one another, the first fold line delineating a boundary between the front wall and the front gusset panel, the second fold line delineating a boundary between the back wall and the back gusset panel, and the third fold line delineating a boundary between the front gusset panel and the back gusset panel, the difference between the distance between the first fold line and the second fold line and the distance between the second fold line and the third line comprising the offset of the front gusset panel from the back gusset panel.

49. A method as in claim 48 wherein the first fold line, the second fold line and the third fold line are all parallel to one another.

50. A method as in claim 48 wherein the first fold line bisects first opposing miter gusset seal regions and the third fold line bisects second opposing miter gusset seal regions, wherein the first opposing miter gusset seal regions are larger than the second opposing miter gusset seal regions.

51. A standup flexible pouch as in claim 50 wherein the first opposing miter gusset regions are larger than the second opposing miter regions in direct proportion to the difference between the length of the front gusset panel and the back gusset panel.

52. A method as in claim 48 wherein the distance between the first fold line and the second fold line is greater than the distance between the second fold line and the third fold line by a ratio of between about 1% to about 99% the gusset width.

53. A method as in claim 52 wherein the distance between the first fold line and the second fold line is greater than the distance between the second fold line and the third fold line by a ratio of between about 10% to about 80% the gusset width.

54. A method as in claim 53 wherein the distance between the first fold line and the second fold line is greater than the distance between the second fold line and the third fold line by a ratio of between about 20% to about 60% the gusset width.

* * * * *