

(19)
(12)

(KR)
(B1)

(51) 。 Int. Cl. ⁶
H01L 27/10

(45)
(11)
(24)

2002 11 04
10 - 0359246
2002 10 18

(21) 10 - 1999 - 0041670
(22) 1999 09 29

(65) 2001 - 0029062
(43) 2001 04 06

(73) 1 838

(72) 606 203 206

(74)
:

(54)

RAM , RAM 가 ,
RAM 가 RAM ,

2i

1

2a 2i

3 1
,

4 2
,

5a 5d
,

6
, 7a 7c
,

<

A : B : RAM

10 : 1 20 : 2

30 : 40 :

40a : (40a) 40b : (40b)

50 : 60 :

70 : 1 75 : 2

100 : 110 : 1

120 : 2 130 : 3

210 : 1 220 : 2

230 : 3 240 : 4

310 : 310a :

410 : 1 410a : 1

410b : 420 : 2

420a : 420b :

430 : 3 430a : 2

440 : 450 : 3

510 : 610 :

610 :

가
 (A) 가 , 1 (capacitance) , 가 RAM (B)
 (logic) (A) ,
 가 가
 (A) , 가
 가 RAM (B) 가 (A)
 (photolithography)
 (A) RAM (B)
 (B) RAM (A)
 RAM (B)
 RAM
 RAM
 가
 , RAM
 가 1 1
 , RAM
 가 2 2 , RAM
 1 1
 , RAM
 3 3
 가 3
 가 2 3 , 3

, 2 , 3
 4 , 2 1
 , 3 2 , 3 ,
 2 , 3 , RAM 2 , RAM
 , 3 ,
 4 ,
 , , RAM
 , RAM 가
 , RAM 1 1
 가 2 , RAM
 1 2 , RAM
 3 , 1 2 1
 가 3 , RAM
 , 1 2 3 , 3
 가 2 3 , 2 2
 , 2 , 3 , 4 , 2 3 2
 , 3 2 3 , 4 , RAM 3 2
 , RAM 3 , 4
 RAM
 가 , RAM
 1 , RAM 가 1 1
 M , 가 2 , RA
 1 3 , RAM 1 2 1
 , 3 가 3 3 3
 , 3 가 2 2 3
 2 , RAM 2 3

가 , RAM , " , RAM 가
 , RAM , 가

[1]

2a 2i

2a (100) (A) RAM (B)
 (transister)가
 1 (110) 1 (110)
 , CMP(chemical mechanical polishing)
 10 1 (n), 20 2 (p),
 30 40 (40a) 70 1 (40b)
 50 60 70 1

2b RAM (B) 1 (210) 1 (110) RAM
 (B) (40b) 1 (contact hole) 1
 () 1 (210) (etch bac
 k) (310, 310a) (A) RAM (B)
 (310a)(dummy plug))
 RAM (B) (40b) (40a)
 (40a)

2 (220) (310) (310a)가

2c 2 (220), 1 (210) 1 (110)
 (bit line) RAM (B) (40a) 1
 (A) (40) (60) 2
 2b 가 2

2 (220) 1 (410)
 (410) 1 (410) 2 (75) 1
 M (B) (410b) (A) 1 (410a) , RA

2d , 2 (75), 1 (410) 2 (220)
 1 (410a) (410b) , 2 (220)
 (310) (310a)

(120) (310) (310a) 2
 , 2 (120)
 , CMP , 3 (230)
 , 3 (230) , (A)
 , RAM (B) 가

2e , RAM 3 (230) 2 (120)
 (310) (310a) 3 3
 0) (,) 2 (420) , 2 (420)
 (230) , 2 (310) (310a) 3
 , 2 (75) 2 (75) 2 (120)
 , 2 (420)

2 (420) (510)
 2 (420) (510) , (510)
 3 (230) (510) 3 (230)

2f , (A) (510), 2 (420), 3 (230), 2
 1 (120) 2 (75) 4
 (410a)

0) , (photolithography) 2 (510), 2 (420) 2 (230)
 (430) 2 3 (430) , 3
 , 4 2 4
 가

2g , 3 (430), (510) 2 (210) 3
 (230) , 2 (420) (420a) (,
)(420b) , 3 (430) 2 (430a) , (4
 20a) (420b) 3 (230)

3 (130)
 , RAM (B) (130) 3
 (130) , 3 (130) RAM (B) (510)
 (A) , (A) (4

20b) 3 (130) .

2h , (510) 3 (230)
 , (510) 3 (230)

, (610) , (610)
 (,) 4 (440) , (A)
 4 (440) (440a) , .

, (610) (420a) HSG
 (hemi spherical grain) , .

2i , (A) 4 (240) 3 4 (240)
 3 (A) 2 (430a) 5 (130)

, 5 (450) , 5
 (450) 3 (450a) , 1

가

[1 - 1]

1 , 1 ,

3 1

3 , 1 2e (510) ,
 (510) 2 (420)

, 2 (420), 3 (230), 2 (120) 2 (75)
 2 1 (410a)

, (photolithography) (510), 2 (420) 3 (23
 0) 2

, (510) 3 (430) , 2 3 (430) , 1
 (510) (420) (510)

, 1 3 (230) 3 (230)
 , 1

, 1-1 , 1 가 , 1 (410a)
 2 (510) 가 .
 , 2 가 (510)

, , 1 , " (510) 3 (230)
 (230)" , , 2 (230) 3 (420)
 , 2 (420) 3 (430) 2 (430)

[1 - 2]

1 , 1 ,

4 2

4 , 1 2e (510)
 3 (230) (510) 2 (420) , 2
 (420) (420a)

, (A) 3 (230), 2 (120) 2 (75)
 , 2 1 (410a)

, (photolithography) 3 (230)
 2 (430)

, 1 3 (230) 1

(230) 1-1 가 , 1 , 3
 , 1 1-1

[2]

5a 5d

, 3 (230) 1 ,
 1 2a 2d

5a , 3 (230) 2 (120) (310)
 (310a) 3 (230)
 (,) 3 2 3 (420) (230)

5b , (A) 2 (410), 3 (230), 2 (120)
 2 (75) , 2
 (410) 3 (230)

3 (430) 2 (420) ()

5c (420) RAM (420b) (B) 2 (A) 3 (420) (420a) 3 (230) (430) (430a) 2 () 3 (230)

(130) (A) 3 (130) RAM (B) 3 (130) (230) (A) 3 (130)

5d 0) 3 RAM (B) 3 (230)

() 4 (610) (440) (A) 4 (440) (440a)

HSG(hemi spherical grain) 1 가 (610) (420a)

1 (510) 가 1

[2 - 1]

6 2

6 (420a) 3 (420b) (230) 2 2a (420) (420)

(A) 3 (230), 2 (120) 2 (75) 3 (230)

(230) 3 (430) 2 (430) (430a) 3

2

, 2 가 , 2 2 (420)

2 (420)

[3]

7a 7c

, (510) 1 2a 2e

, 1 (510)

20) 7a , 3 (230) (510) 2 (4
, 3 (230) (510) (420) (420a) (420b)

, 3 (130) RAM (B) (130) 3
(130) RAM (B) (510) 3 (230) 3
, 3 (130) RAM (B) (510) 3 (230) (A)
420b) 3 (130)

7b , (510) 3 (230) (510) 3 (230)

7c , (610)
(440a) , (A) RAM (B) 가 RAM
(B) (130) (610) (420a) H
SG(hemi spherical grain)
, 2

(A) 가 RAM (B) RAM (B)
(A) 가

가

가

(57)

1.

2.

(60) (A) (A) RAM (A) (B) RAM (B) (40a), (40b), (50), 가 (100), (110) 1 (3)

10) (210) (310a) RAM (B) (100) (40b) 1 (110) 1 (3)

RAM (310) (B) 2 (310a)가 (40a) (410) (A) 2 (40) (220) (60) (410b) 1 (410a) 1 (410a)

1 (410a) (410b) 3 (230)

RAM (310) (B) 3 (310a) (230) 3 가

0) 3 가 2 (420) (51)

(A) (510), 2 (420), 3 (230) 1 (410a) (310) (310a) 4 (510), 2 (420) 2 (230)

4 (510) 2 (210) 3 (230) (430), 3 (430), (420) (A) 3 (420a) (430) 2 (430a) RAM (B) (430), (A) 3 (430) 2 (430a) ;

RAM (B) (510) 3 (230) ;

(610) ;

(A) (610) 4 (440)

3.

2 ,

1 (410) , 2 (75) 가 ,

1 (410a) (410b) , 2 (120)
가 ,

(420a) (420b) , 2 (430a)
3 (130) 가 RAM (B) 3 (130)
(510) 3 (230)

4.

2 ,

4 (510) 2 (420) 3 (510) 2 (420) ,
(510) 2 (420) 3 (230)

5.

(A) RAM (B) (40a), (40b), (50),
(60) 가 (100)
(A) , RAM (B) ,

(210) , RAM (B) (100) 1 (110) 1
10) (310a) ; (40b) 1 (3

RAM (310) (310a)가 (2) (220) ,
(B) (40a) (A) (40) (60)
(410b) 2 ; 1 (410) 1 (410a)

1 (410a) (410b) 3 (230)
;

RAM (B) 3 (230) , 가
(310) (310a) 3 ;

3 가 2 (420)
;

(A) (510), 2 (420), 3 (230)
4 , 2 (420) 2 (230) ;

4 (430) , 3 (430)
2 (210) 3 (230) , RAM (B) 2 (4
20) (420a) (420b) , (A) 3 (43
0) 2 (430a) ;

RAM (B) 3 (230) ;
 (610) ;
 (A) (610) 4 (440)

6.
 5 ,
 1 (410) , 2 (75) 가 ,
 1 (410a) (410b) , 2 (120)
 가 ,
 4 , 2 (420) 3 (230)
 ,
 3 (420a) (420b) , 2 (430a)
 3 (130) 가 RAM (B) 3 (130)
 3 (230)

7.
 (A) RAM (B) (40a), (40b), (50),
 (60) 가 (100)
 (A) , RAM (B) ,
 가 (100) 1 (110) 1
 (210) , RAM (B) (40b) 1 (3)
 10) (310a) ;
 RAM (310) (310a)가 2 (220) ,
 (B) (40a) (A) (40) (60)
 2 1 (410) 1 (410a)
 (410b) ;
 1 (410a) (410b) 3 (230)
 ;
 RAM (B) 3 (230) , 가
 (310) (310a) 3 ;
 3 가 2 (420) (51)
 0) ;
 3 (230) (510) 2 (420)
 2 (420) (420a) (420b) ;

RAM (B) (510) 3 (230) ;
 (610) (440) (A)

8.

7 ,
 1 (410) , 2 (75) 가 ,
 1 (410a) (410b) , 2 (120)
 가 ,
 가 (420a) RAM (B) (420b) 3 (130) 3 (130) (230)

9.

2 , 5 7 ,
 3 (230) (420a) HSG(hemi spherical grain) , (610)

10.

2 , 5 7 ,
 1 3 (210 230)

11.

2 , 5 , 7 ,
 (A)

12.

3 6 ,
 (510) 3 (230)

13.

3 , 6 8 ,

1 3
(130)

(110 130)
(420b)

3 , RAM (B)
(130)

3

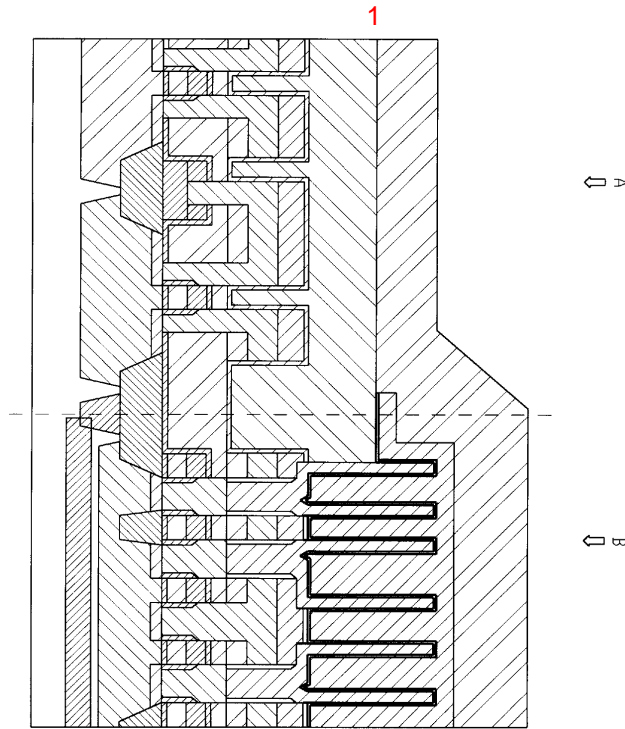

2a

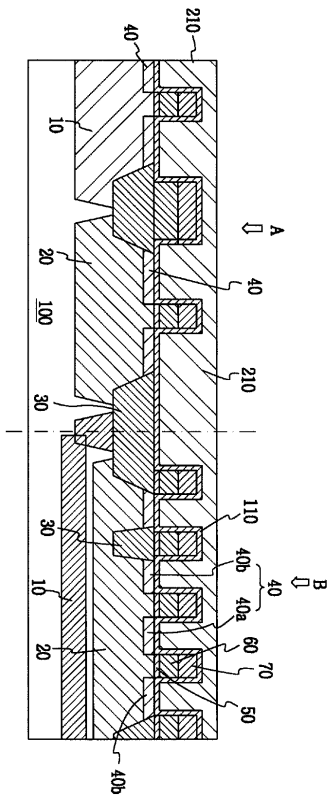

2b

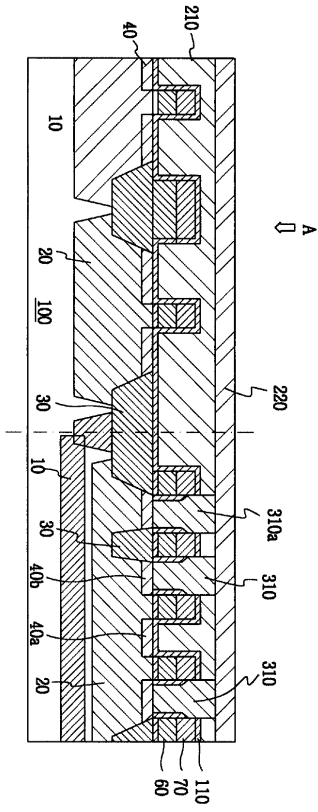

2c

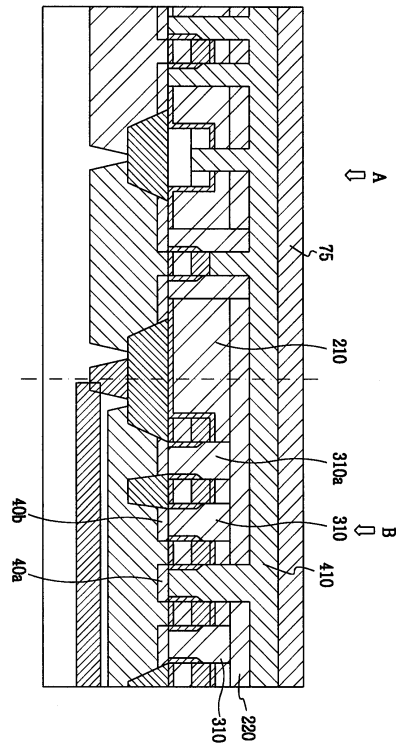

2d

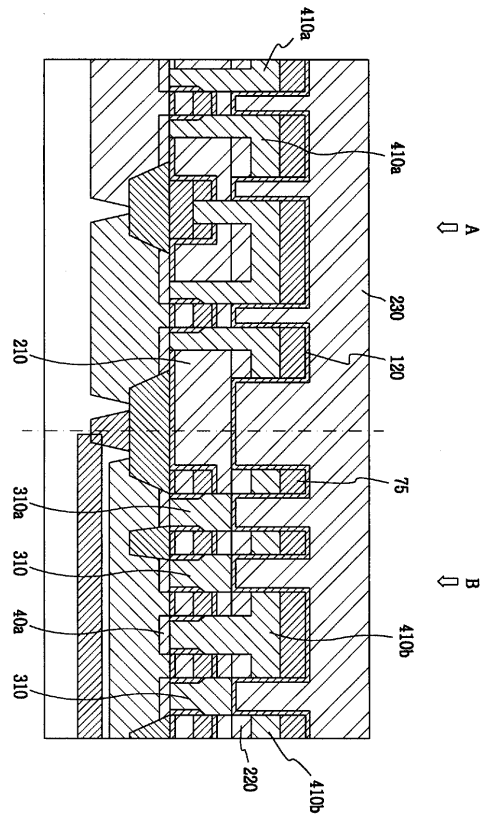

2e

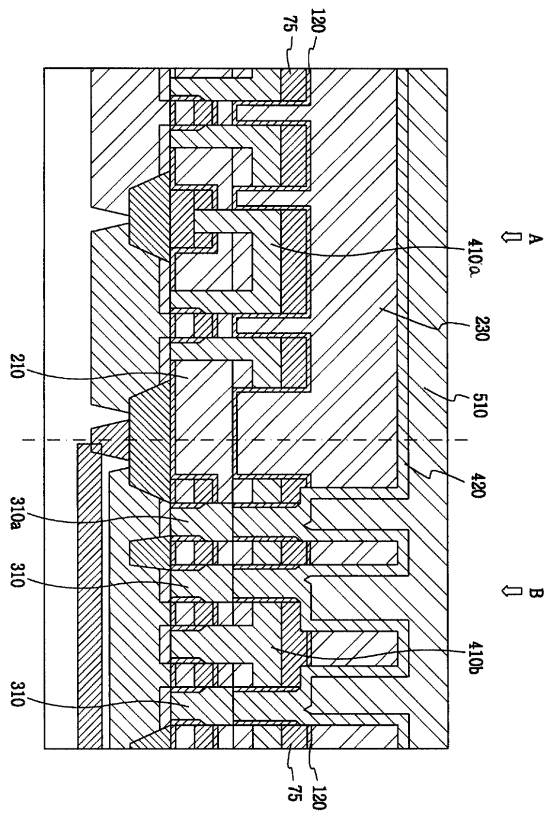

2f

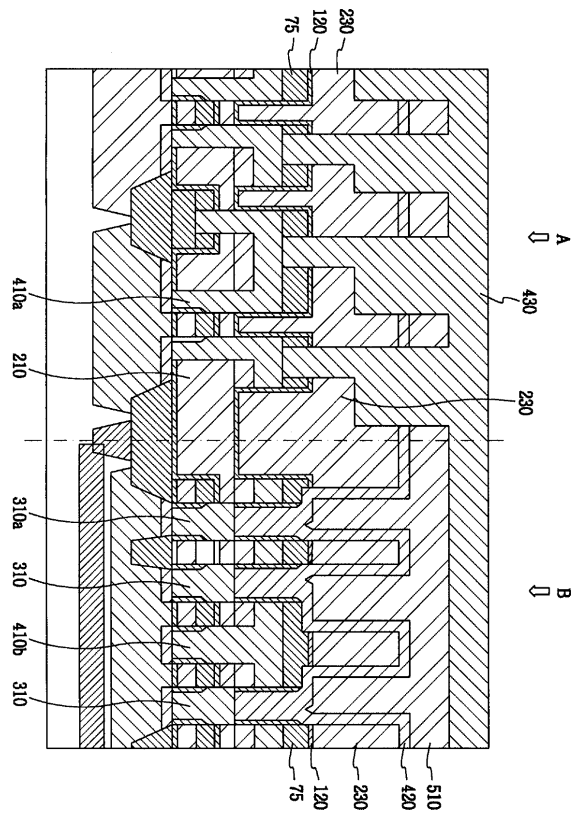

2g

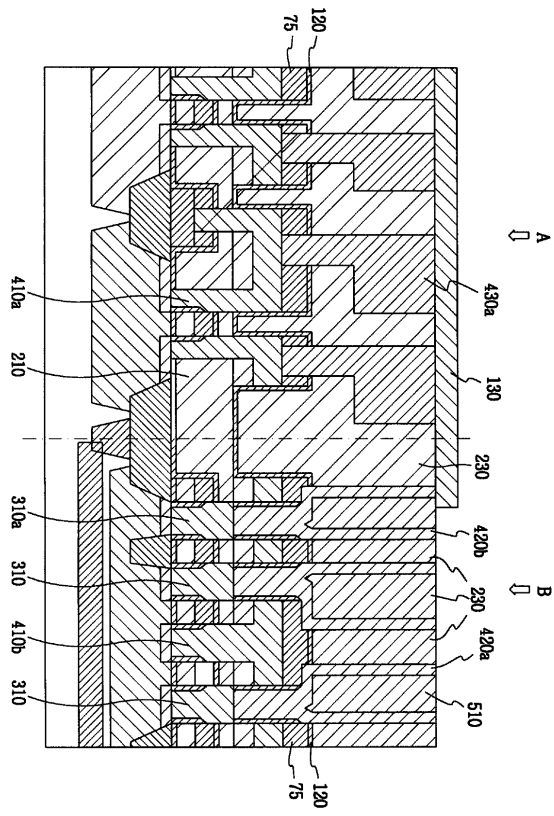

2h

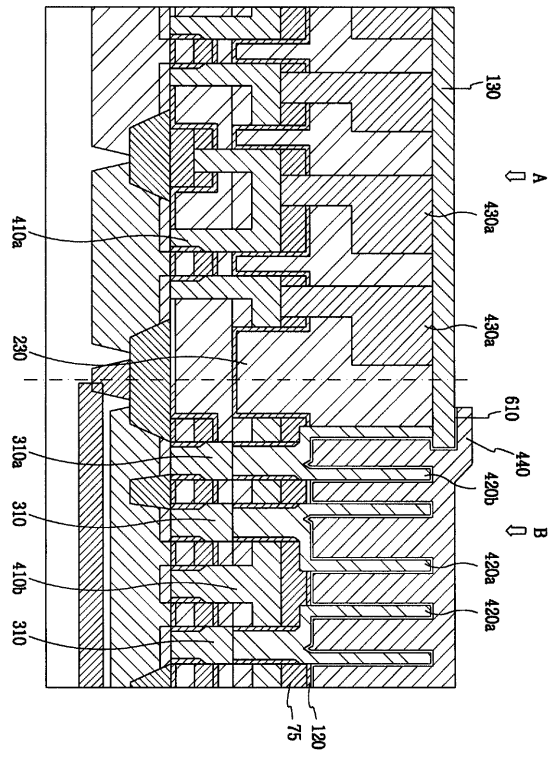

2i

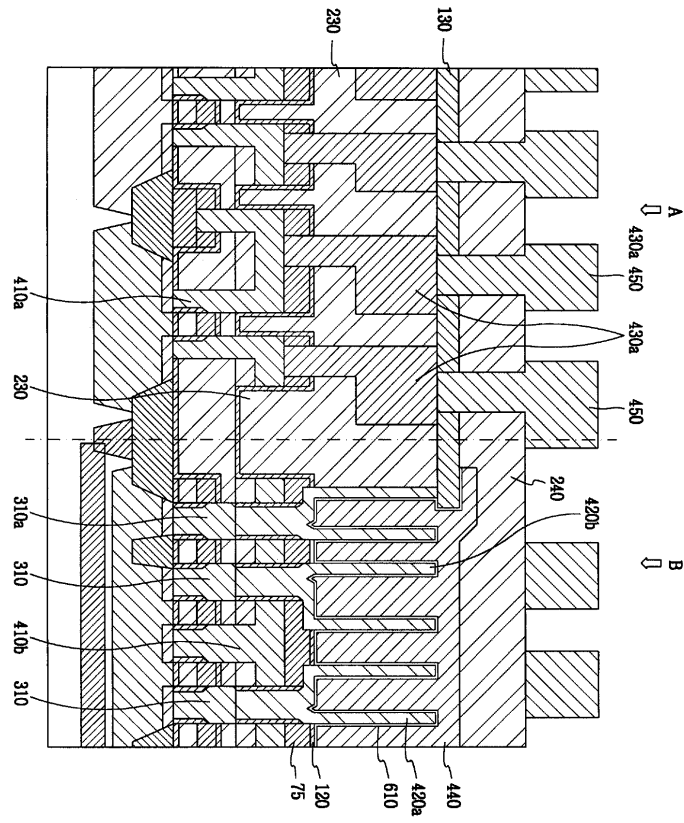

3

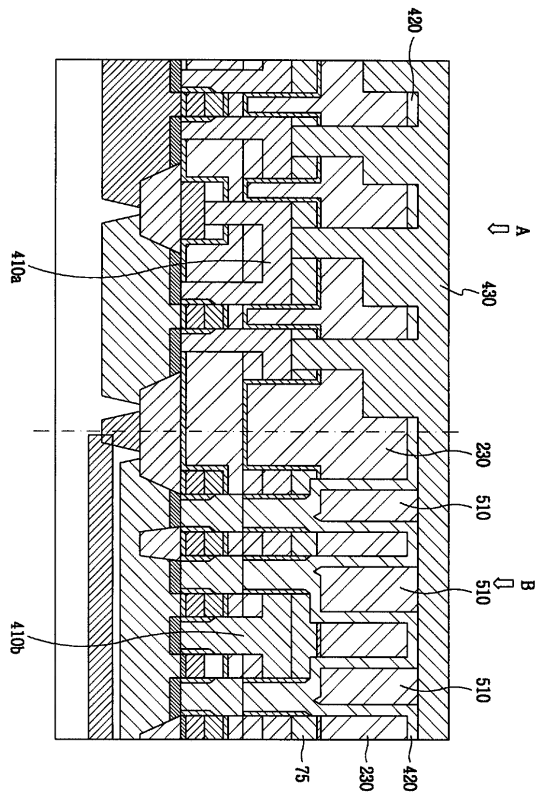

4

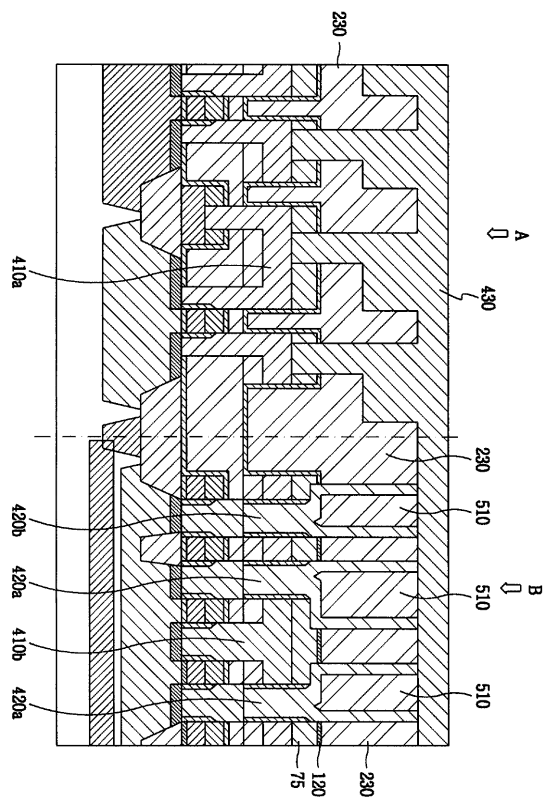

5a

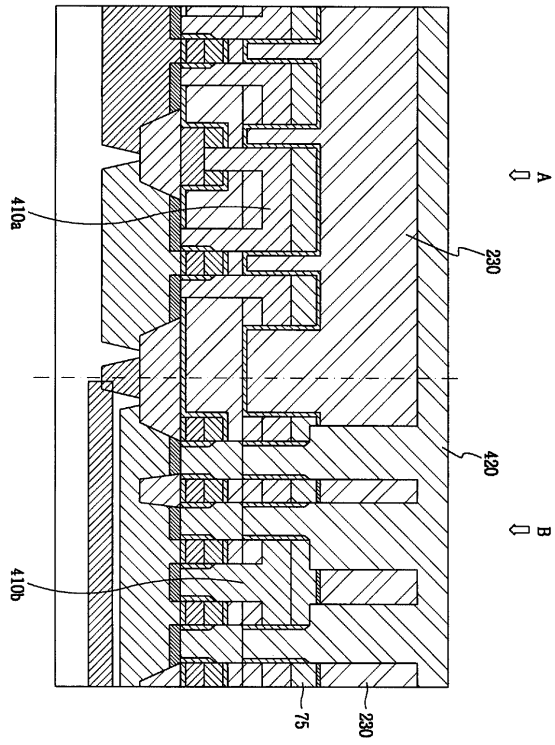

5b

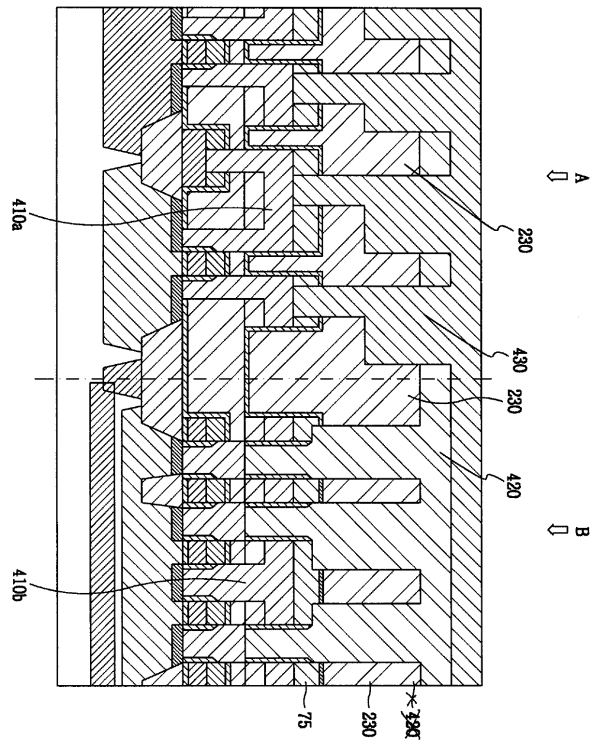

5c

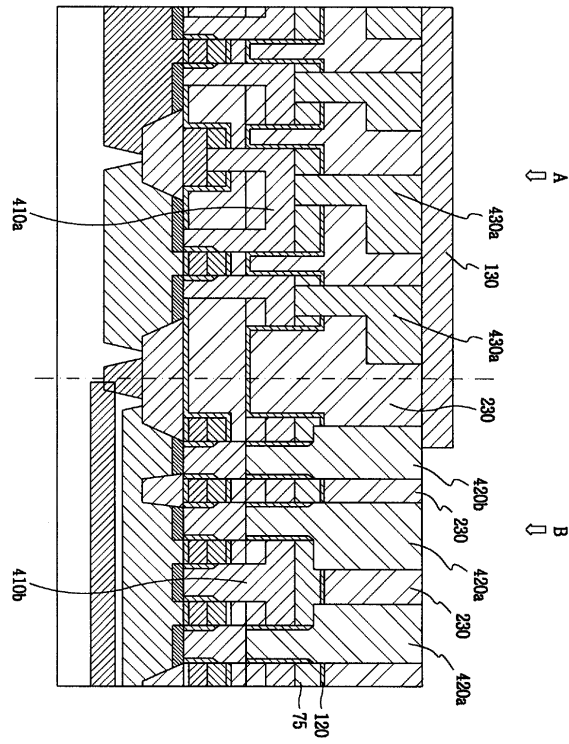

5d

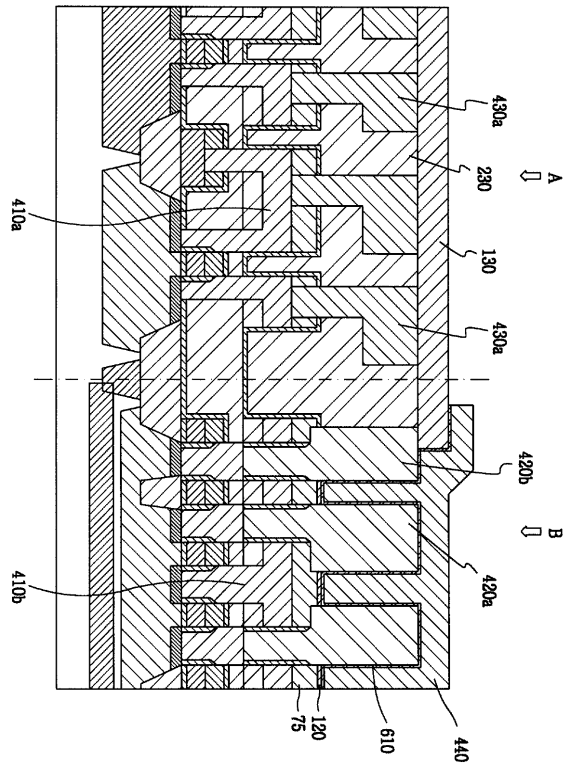

6

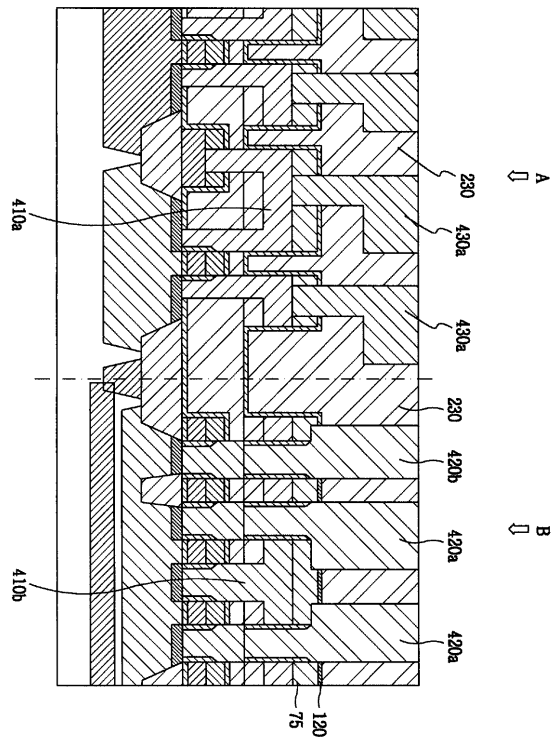

7a

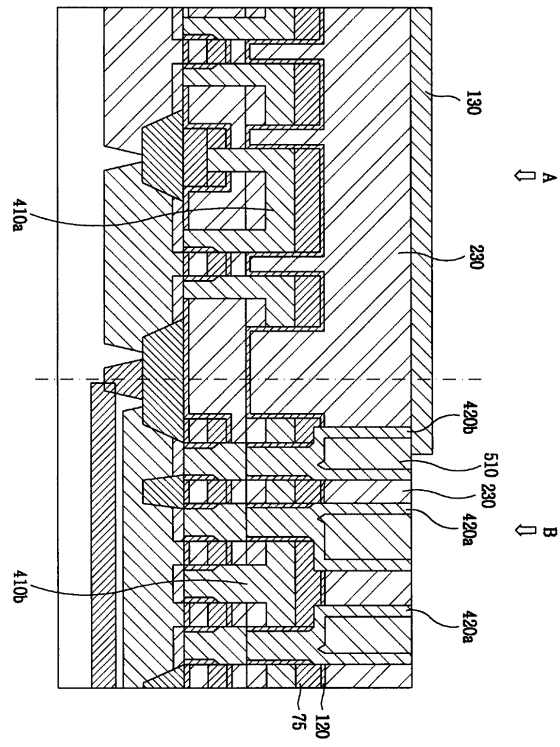

7b

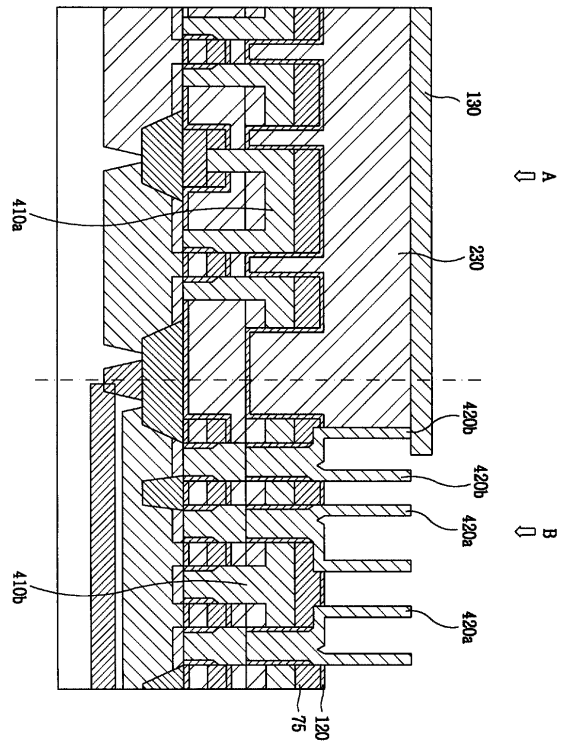

7c

