

(No Model.)

3 Sheets—Sheet 2.

E. P. SLENTZ & J. B. MCGREW.
ELECTRIC RAILWAY.

No. 424,364.

Patented Mar. 25, 1890.

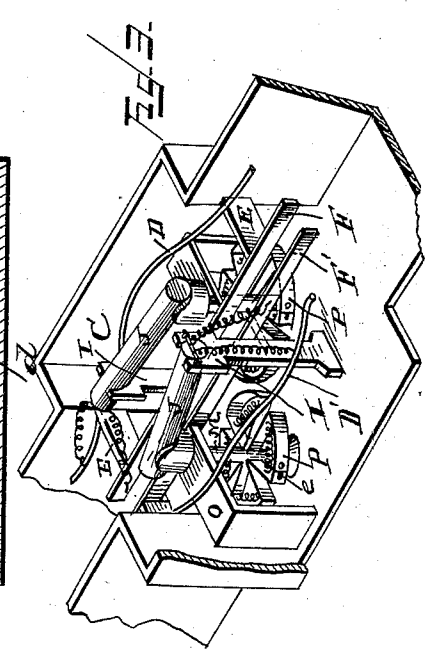
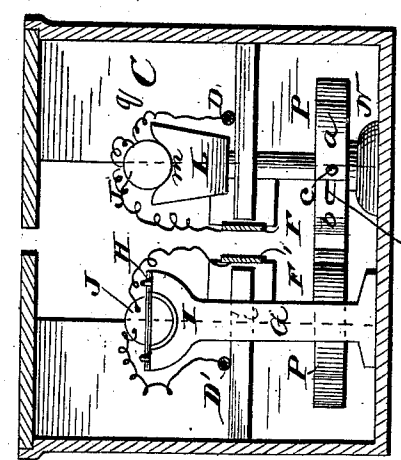
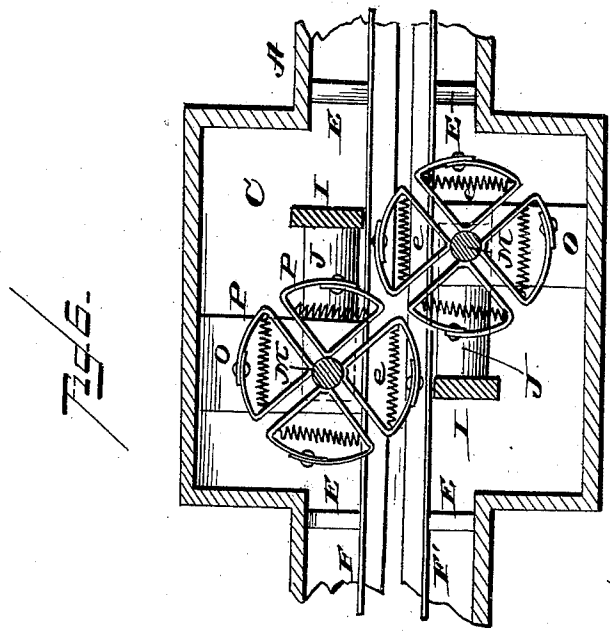

WITNESSES:
F. L. Ourand
C. F. Shisholm

INVENTORS:
Edmund P. Slentz
James D. McGrew
By Louis Dugger & Co
Attorneys

UNITED STATES PATENT OFFICE.

EDMUND P. SLENTZ, OF IDLEWOOD, AND JAMES B. MCGREW, OF PITTSBURG,
ASSIGNORS OF THREE-EIGHTHS TO JOHN A. SNEE, OF PITTSBURG, PENN-
SYLVANIA.

ELECTRIC RAILWAY.

SPECIFICATION forming part of Letters Patent No. 424,364, dated March 25, 1890.

Application filed August 13, 1889. Serial No. 320,604. (No model.)

To all whom it may concern:

Be it known that we, EDMUND P. SLENTZ and JAMES B. MCGREW, residents, respectively, of Idlewood and Pittsburg, both in the county of Allegheny and State of Pennsylvania, have invented certain new and useful Improvements in Electric Railways; and we do hereby declare that the following is a full, clear, and exact description of the invention, which will enable others skilled in the art to which it appertains to make and use the same, reference being had to the accompanying drawings, which form a part of this specification, and in which—

Figure 1 is a longitudinal sectional view, on a vertical plane, of our improved electric railway, showing a car upon the track. Fig. 2 is a plan view of the underground conduit with its appurtenances. Fig. 3 is a perspective detail view of one of the conduit-boxes and apparatus for automatically breaking and closing the electric circuit over a given distance or portion of the conduit. Fig. 4 is a side view of the same device or apparatus with one side of the inclosing-box broken away. Fig. 5 is a similar view of the same apparatus, but at right angles to the view shown in Fig. 4. Fig. 6 is a bottom plan of the same. Fig. 7 is a transverse sectional view through the vertical plane indicated by the broken line marked xx in Fig. 2. Fig. 8 is a longitudinal sectional view on a vertical plane through line yy in Fig. 2. Fig. 9 is a detail view of the circuit closing and breaking device which forms a part of the apparatus, and Fig. 10 is a detail view of the device for revolving the movable bearings for the circuit closing and breaking device shown in Fig. 9.

Like letters of reference denote corresponding parts in all the figures.

Our invention relates to electric railways of the type in which the conduit and electric cables are located under ground, the working current being conveyed to the electric motor in the car by means of contact-brushes at the lower ends of arms affixed to the car and projecting down into the conduit-trough through a narrow slit in the covering-plate. In this type of conduits it has been found extremely difficult to prevent great waste by leakage, so that a current of high potential-

ity has to be maintained to obtain enough surplus power to run the cars, especially during the wet seasons of the year, when the conduit-trough is apt to be more or less filled with half-melted snow or water.

The object of our invention is to overcome this serious drawback which attaches to that class of electric roads, and we accomplish this in a simple and effective manner by rendering the conducting-strips from which the car takes its power "dead" or inactive throughout the entire length of the route, except for a short distance corresponding, approximately, to the length of the car, which (the car) as it advances over the track gradually and automatically shifts the active portions of the conducting-strips from one section of the same to another from the beginning to the end of the track and in advance of the line of travel. This progressive "rendering active" by sections of the conducting-strips which supply the car with power for its propulsion is accomplished automatically and mechanically by the car itself, substantially as will be hereinafter more fully described.

Reference being had to the accompanying three sheets of drawings, the letter A designates the underground trough or conduit in the middle of the track. (Shown at B.) At a suitable distance apart, which should correspond to the length of the cars used on the line, (say about sixteen feet, more or less,) are located boxes C, which contain the mechanism for shifting the active sections of the conducting-strips as the car progresses over the line. Running through these boxes, as well as through the intermediate trough-sections A, are the insulated line-cables D and D', suspended from or supported upon suitable hangers or brackets E on opposite sides of the troughs A and boxes C. Passing longitudinally through the middle of the trough-boxes are the uninsulated or naked conducting-strips F and F', which are simply flat strips or bars of suitable metal, also carried by but insulated from the cable-supports E, said strips F and F' running through the entire line of conduit and boxes parallel to and between the line-cables D and D'.

In the space between the insulated cable D

55

60

65

70

75

80

85

90

95

100

and its corresponding naked strip F is located, in each of the boxes C, a vertical fixed upright or standard G, the upper end of which forms journals H for the horizontal bearing I of a hollow cylinder or cylindrical box J, closed at both ends and containing a ball or sphere K of metal. The free end of the cylinder J is supported movably in the bifurcated head L of another standard M, which is, however, movable around its own axis, its lower end being stepped loosely into a bearing N in the bottom of the box, while its upper end is inserted loosely through a guide bracket or bearing O, projecting inwardly from the adjacent side of the box, so that said standard M, with its forked head L, is free to revolve in its bearings N and O. This movable or revolving standard L M forming, as we have seen, a bearing or support for the outer end of the movable cylinder, is provided near its lower end with four arms or projections P, arranged in a horizontal plane at right angles to one another. Each of these arms consists, in the present illustration of this part of our invention, of two plates or strips of steel or other tough and elastic metal (see Figs. 6 and 10) *a* and *b*, the inner ends of which are fastened in the revolving standard M, while their flaring or diverging outer ends are bent toward and overlapping each other endwise, and connected movably by a headed bolt *c*, fastened to one of the arms *a* and projecting through a slot *d* in the other arm *b*. The arms *a* and *b* have placed between them at their widest part, or point of greatest divergence, a stout spiral spring *e*, which acts as a buffer or cushion, as will be hereinafter described.

The upper ends of the forked head L are rounded, as shown at *l*, and are also rounded or beveled on their inner sides, as shown at *m*, so that when the standard M, with its forked head or saddle L, is given a quarter of a turn it will lift the free end of the cylinder up into an inclined position, as shown by the dotted lines—*i. e.*, inclined from the saddle L toward the fixed bearing G. When, on the other hand, the apparatus is in its normal position, cylinder J will be inclined in the opposite direction, viz: the end resting in the saddle L is then the lowest point and its hinged end the highest, which position is illustrated in full line on the drawings. When the cylinder is in the latter or normal position, the interior ball or sphere K will of course rest in the lowest part of the cylinder just above the saddles; but when the cylinder is tilted into the other position (shown in dotted lines) by a one-quarter revolution of the saddle then the ball will by its own gravity roll down into the other end, which is then the lowest. Within this end of the cylinder are placed two insulated metallic contact-plates Q and R, one of which Q is connected by an insulated wire *q* with the line-wire within the insulated cable D, while the other R is similarly connected by an insulated wire *r* with the appropriate naked conducting-strip F. Under

normal conditions, therefore, the current cannot pass from cable D into strip F, but when the cylinder is raised or tilted the ball, rolling down into that end, will rest or bear against and establish metallic connection between the two contact-plates Q and R, thus permitting the current to flow from cable D through the wire *q*, contact-plate Q, ball K, plate R, and wire *r* to the naked strip F. The current is again broken or shut off the moment the free end of the cylinder is lowered back into its normal position by the ball leaving the contact-plates Q and R, and thus breaking connection between them. On the opposite side of each of the boxes, between the other cable D' and its appropriate conducting-strip F' appertaining to that side of the box, is located a precisely similar device, comprising a fixed standard, a standard adapted to revolve around its own axis and provided with projecting arms or wings at its lower end, constructed as described, a bifurcated head or saddle, and a pivoted cylinder adapted to be moved or tilted in a vertical plane parallel to the sides of the box, and provided with its appropriate contact-ball, contact-plates, and insulated wires connecting said plates with respectively the line-cable and the naked conducting-strip. The only difference is that the position of this second cylinder with its appurtenances is reversed—*i. e.*, both cylinders, while parallel to each other, tilt or swing in opposite directions when actuated or operated by their respective revolving standards M and saddles L.

Having in the foregoing described the construction of our apparatus, we shall now proceed to explain its operation, which is as follows: Each car is provided at opposite ends with a downwardly-projecting arm or bar S, of such dimensions that it will enter and run freely in the slit in the plate covering the conduit trough and boxes in substantially the same manner as the grip-levers used on cable cars. As the car is started along the track the forward arm S will strike the arms or wings P of the two revolving standards M M in the first box, and thereby give to each of these a one-quarter turn, which tilts their respective cylinders into the position shown in dotted lines, thereby closing the circuit on both sides between the pair of strips F F' appertaining to the first box and its appropriate conduit-section. As these conducting-strips F and F' are not continuous, but broken into lengths of appropriate size corresponding to the length or distance between the two depending arms of the cars, which are arranged endwise in close proximity to one another, as shown in Fig. 1, it follows that only that particular length or section of strips F and F' which appertains to that particular box is rendered active by the closing of the circuit between it and the line-cables, the connecting-strips over the remainder of the line being dead or inactive. The motor within the car is supplied with power from this act-

ive section just underneath the car by contact-brushes in the usual way, brushing against the strips, and as the car leaves the portion of track over this active section the rear arm S will in its turn strike the wings P, and thereby tilt the circuit-closing cylinders back into their normal position, thus shutting off the current from the line-cables to the conducting-strips. At the same moment the forward arm of the car will have reached and operated the apparatus in the next box, thereby rendering the next section of conducting-strips F F' active, and so on over the entire length of the line, the forward arm S opening and the rearward arm closing the circuit which renders active the appropriate pair of conducting-strips F and F' appertaining to the particular length or section of track over which the car is moving and from which it is to take its power.

By constructing the operating wings or arms P, as described, with the buffer-springs e they will receive the blows of the depending arms S without injury, and will also cause the standards M to revolve smoothly and easily and without jarring. By using four of these wings upon the revolving standards instead of two, cars may be run forward or back upon the same track, as the apparatus may be operated from either side with equal facility and certainty of operation.

Having thus described our invention, we claim and desire to secure by Letters Patent of the United States—

1. In an electric railway, the combination, with two insulated conductors forming the electric circuit, of a series of conducting-strips, a cylinder connected with said strips and conductors and journaled at one end in a fixed support and its other end resting in a rotating support by which it is raised and lowered, a ball or sphere in said cylinder, actuated by gravity to make electrical connection between the conductors and strips, and means by which the cylinder-support is rotated automatically, substantially as described.

2. In an electric railway, the combination, with a continuous cable and a series of broken conducting-strips, of a cylinder journaled at one end in a standard and its other end resting in a rotating or revoluble support, insulated plates in the end of the cylinder in proximity to the journals, wires connected with said plates and with the cable and conducting-strips, respectively, a ball or sphere located in said cylinder and actuated by gravity to make electrical connection between the plates in the cylinder, and means, substantially as described, for revolving the cylinder-support automatically by a moving car, substantially as set forth.

3. In an electric railway, the combination, with a continuous cable and broken strips, of a cylinder journaled at one end in bearings in a fixed support, a revoluble support having a bifurcated head in which the other end of the cylinder rests, insulated plates in the

interior of the cylinder, wires connecting the plates with the cable and strips, respectively, a ball or sphere in said cylinder, actuated by gravity to be brought into and out of contact with the plates to make and break electrical connection therewith, and means whereby said support is automatically rotated by the moving car, substantially as described.

4. In an electric railway, the combination, with a continuous cable and broken strips, of a cylinder journaled at one end in a fixed support, a revoluble support having a bifurcated head in which the other end of the cylinder rests, conducting-plates in the interior of the cylinder, insulated therefrom and from each other, wires connecting said plates with the cable and strips, respectively, a ball or sphere in said cylinder, actuated by gravity to make and break electric contact with said plates, and projecting arms secured to the revoluble support against which a depending rod or bar on a moving car is adapted to strike and rotate the support, substantially as described.

5. In an electric railway, the combination, with a continuous cable, of a series of conducting-strips with which the brushes of a car are adapted to engage, an upright having a bifurcated end, a cylinder having journals working in bearings in said bifurcated end, a revoluble support having a saddle at its upper end in which the other end of the cylinder rests, metallic insulated plates in the cylinder, wires connecting said plates, respectively, with the cable and conducting-strips, a gravity sphere in the cylinder, a series of spring-arms on the revoluble support, against which a depending bar or arm from a car is adapted to strike, substantially as described.

6. In an electric railway, the combination, with a continuous cable and a series of conducting-strips, of a fixed support G, a cylinder J, journaled in the upper end of said support, the plates Q R in said cylinder insulated therefrom and from each other, wires q r, connecting said plates, respectively, with the cable and the strips, a sphere K in said cylinder, actuated by gravity to make and break connection with plates Q R, a revoluble support M, having a saddle L, in which the free end of the cylinder rests, a series of arms secured to support M, each consisting of two strips of metal a and b, the inner ends of which are fastened to the support M, while their flaring or diverging ends are bent toward and overlapping each other endwise and connected by a bolt c, and a spiral spring e, interposed between the strips a b, substantially as described.

7. The combination, in an electric railway, of a track, a car adapted to run on said track, an underground trough situated between the rails of said track and having a narrow slit or opening, and a series of equidistant boxes, depending arms extending from the car through said slit into the trough, an insulated cable, naked separated strips arranged in pairs at

each of said boxes, cylinders journaled at one end in fixed supports and at their other ends resting in revoluble supports, having saddles by which said ends are raised and
5 lowered by the rotation of the support, insulated plates in the cylinders, wires connecting said plates with the cable and with the naked strips, spheres located in the cylinders and actuated by gravity to make and
10 break electrical contact with the plates, spring-arms on the revoluble supports, by which they are rotated by the depending arms

on the car, and electrical connections between the naked strips and the motor on the car, substantially as described. 15

In testimony that we claim the foregoing as our own we have hereunto affixed our signatures in presence of two witnesses.

EDMUND P. SLENTZ.
JAMES B. MCGREW.

Witnesses:

L. H. MATHEWS,
WM. WATSON.