

(19) World Intellectual Property Organization
International Bureau



(43) International Publication Date
15 February 2001 (15.02.2001)

PCT

(10) International Publication Number
WO 01/11506 A1

- (51) International Patent Classification⁷: **G06F 17/40**, 17/60, H04L 12/66
- (72) Inventors; and
(75) Inventors/Applicants (*for US only*): **SIM, Lim, Or** [MY/AU]; 19 Haversham Avenue, Wheelers Hill, VIC 3150 (AU). **CHEONG, Yee, Han** [MY/AU]; 19 Haversham Avenue, Wheelers Hill, VIC 3150 (AU). **JARRETT, Andrew, Lawrence** [AU/AU]; 7 Liberty Avenue, Rowville, VIC 3178 (AU). **BEY, Shefik** [AU/AU]; 12 Cromwell Crescent, South Yarra, VIC 3141 (AU). **EUSTACE, Anthony, Roger** [AU/AU]; 233 Highett Street, Richmond, VIC 3121 (AU). **PETTIT, Matthew, James** [AU/AU]; 14 Currajong Avenue, Camberwell, VIC 3124 (AU).
- (21) International Application Number: PCT/AU00/00937
- (22) International Filing Date: 7 August 2000 (07.08.2000)
- (25) Filing Language: English
- (26) Publication Language: English
- (30) Priority Data: PQ 2063 6 August 1999 (06.08.1999) AU
- (74) Agent: **FREEHILLS CARTER SMITH BEADLE**; 101 Collins Street, Melbourne, VIC 3000 (AU).
- (71) Applicant (*for all designated States except US*): **RED SHERIFF LIMITED** [AU/AU]; Level 7, 10 Queens Road, Melbourne, VIC 3004 (AU).
- (81) Designated States (*national*): AE, AG, AL, AM, AT, AU, AZ, BA, BB, BG, BR, BY, BZ, CA, CH, CN, CR, CU, CZ, DE, DK, DM, DZ, EE, ES, FI, GB, GD, GE, GH, GM, HR,

[Continued on next page]

(54) Title: NETWORK RESOURCE MONITORING AND MEASUREMENT SYSTEM AND METHOD

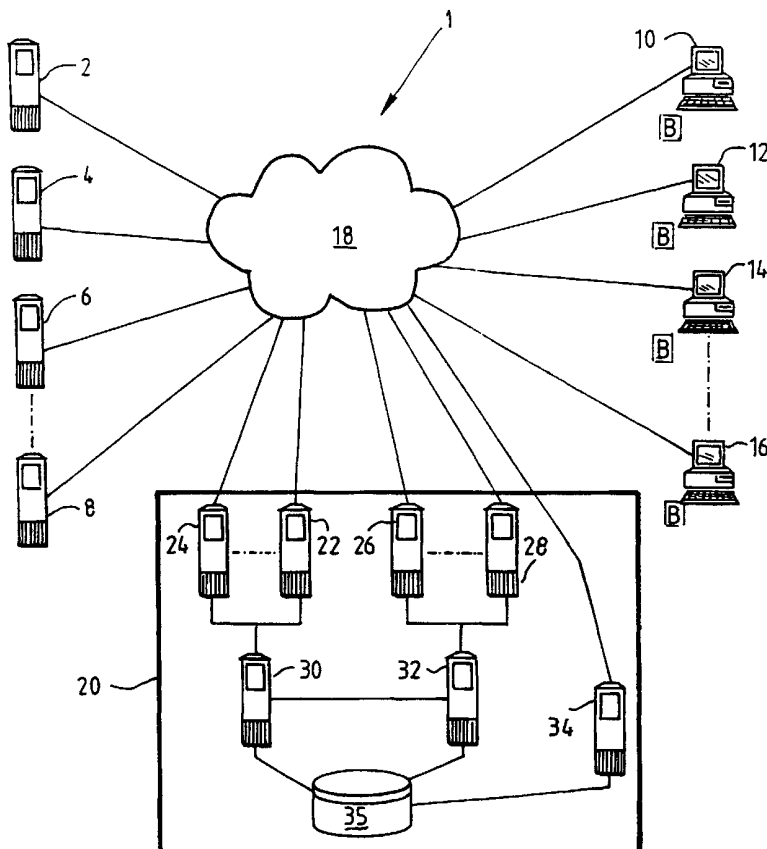

(57) Abstract: A method and system for analysing and measuring multiple sources of data over a communications network (18) so as to ascertain information or usage of one or more resources, such as resource servers (2). A data collection and processing means (20) collects and processes the data sources which are forwarded to a reporting server (34) as a combined data source made available to interested parties.

WO 01/11506 A1



HU, ID, IL, IN, IS, JP, KE, KG, KP, KR, KZ, LC, LK, LR, LS, LT, LU, LV, MA, MD, MG, MK, MN, MW, MX, MZ, NO, NZ, PL, PT, RO, RU, SD, SE, SG, SI, SK, SL, TJ, TM, TR, TT, TZ, UA, UG, US, UZ, VN, YU, ZA, ZW.

IT, LU, MC, NL, PT, SE), OAPI patent (BF, BJ, CF, CG, CI, CM, GA, GN, GW, ML, MR, NE, SN, TD, TG).

Published:

— *With international search report.*

(84) Designated States (regional): ARIPO patent (GH, GM, KE, LS, MW, MZ, SD, SL, SZ, TZ, UG, ZW), Eurasian patent (AM, AZ, BY, KG, KZ, MD, RU, TJ, TM), European patent (AT, BE, CH, CY, DE, DK, ES, FI, FR, GB, GR, IE,

For two-letter codes and other abbreviations, refer to the "Guidance Notes on Codes and Abbreviations" appearing at the beginning of each regular issue of the PCT Gazette.

NETWORK RESOURCE MONITORING AND MEASUREMENT SYSTEM
AND METHOD

TECHNICAL FIELD

5

The present invention relates to a system and method for measuring and/or analysing usage of resources. More particularly the present invention relates to measuring and/or analysing usage of resources on a network using data sources retrieved from actions performed by users of the resources, such measurement and/or analysis providing information about resources that do not have available statistics, (such as site centric measurements) and combining them with site centric data to create a more accurate whole of market picture or components thereof.

BACKGROUND ART

15

In the light of high penetration of Internet use and the rapid growth of the on-line industry, there has become a need for an accurate and independent Internet site rating service. Such a service should provide on-line industry users and organisations and other interested parties with a precise vehicle with which to assess vital Internet site traffic dynamics. For example, it would be advantageous for such users and organisations to have an accurate picture of the information that Internet users were viewing on and interacting with particular websites, as well as the range of sites that target markets were visiting, the advertisements being viewed and how particular sites compared statistically with competitor sites. This type of commercial information is invaluable to those in the on-line industry wishing to properly target their markets and also focus their on-line presence.

Furthermore, to date there has been no product or service for the on-line industry users and organisations that provides a total market rating system that uses site centric measurements, such as proxy and server log files, browser based measurements, and user centric measurements, such as panel data and sample survey data. Furthermore, site and user centric measurements have not been used to

- 2 -

collect data relating statistics pertaining to , for example, a website that has no site centric measurement data available. By providing the sites with such information it provides a more accurate picture about the Internet population and which sites the population use or visit regardless of whether the site centric measurements are
5 available or not for a particular site.

A syndicated multi media marketing data base has been used in Australia which integrates consumer demographics, product usage and media consumption for value-added marketing and media solutions. The data base enables advertising planners, buyers and users to target their advertising campaigns and to plan and
10 evaluate integrated media campaigns based on the only official buying and selling currencies for mainstream Australian media. The data base utilises the strengths of the media industries most widely used research tools such as TV ratings data, radio ratings data, readership surveys and service usage questionnaires. Each reporting period the operator of this data base uses a combination of data to integrate TV
15 viewing data, updated each period, at the program level into a respondent single source data set which may comprise up to say 40,000 respondents. This method is used as a more integrated method of producing data sets capable of cross-referencing television with other media and consumption variables. This approach allows viewing information from the audited television ratings to be analysed
20 against usage, consumption and other media information. The television data base is refreshed periodically so that the most current television program data is available with ratings consistent with the operator of the data base.

The abovementioned system does not allow the “fusion” of one data source created from measuring interactions of a sample of users in relation to their use of
25 the resources, for example use of the internet, and a further source of data pertaining to interactions provided by all users of the resource, measured from for example a website, or viewers of a program measured by a television station to obtain accurate estimates of traffic densities at for example a particular website or television program where the particular website or television station does not have the further
30 source available.

Known measurement techniques include that of a server log file analysis. In this method a log file is kept on the server of all record files requested, IP addresses of those visiting the site as well as successful downloading of all resources delivered from the site server. This method, however is not necessarily an accurate indication of resources used and/or viewed on the site, due to the method not being able to account for resources that are subsequently stored in proxy server caches or browser caches and are re-viewed. For example popular web pages may be stored on various Internet Service Providers (ISPs) proxy servers around the world, so that the ISPs do not need to directly access a popular site every time a user requests access to that site. The ISP simply provides access to their stored version of the site. This enables the ISPs to provide a more efficient service, but results in a less accurate measurement service due to the inability to monitor caches.

Similarly, once a site is accessed, site resources are saved in the user's browser cache, while in use. While the server log file analysis may have recorded data relating to the accessed resources at the time they were accessed, if the user then returns to one or more pages, such as by hitting the "back" button on their browser, then the resource being returned to is typically accessed from their browser cache, so that once again this page request is not recorded by the server log file.

Another method used by some organisations is the so-called browser based measurement approach. In this method, software monitors site resources as they are viewed within a browser. This software monitors the user's actions when accessing the Internet. While this approach does not suffer the accuracy problems of server log file analysis, a problem that does exist with this approach is that for a complete market analysis all sites need to be willing to agree to install the measurement code on every site page. In practice, it has proven quite difficult to obtain cooperation with all sites.

In another method, also used by some organisations, Internet users are recruited and their individual usage of the Internet is monitored to be used in statistical analysis. Usage is monitored by installing hardware and/or software on the user's computer. This hardware or software is not transparent for the user and is often quite onerous, requiring the user to log the software on each time they use it.

An example of this method is provided in US Patent No. 5,675,510, where personal computer use is measured through the use of a hardware box physically located on the user's computer. This hardware records log files of Internet access by the user. This process is expensive due to the hardware costs, installation costs and maintenance and support costs. Furthermore, the process is quite obtrusive, as the users are very conscious of the tracking as they see the box every time they use their PC. Furthermore, the process does not track access of monitored users where for example, a monitored user accesses the internet at a location other than at the user's home or work. Examples of location that are not monitored are cyber cafés, educational facilities, friend's homes etc.

There is considered to be a need for an alternative measurement approach that provides accurate results and also has improved transparency for the user.

SUMMARY OF THE INVENTION

15

According to a first aspect of the invention there is provided a method of measuring and analysing multiple data sources over a communications network in order to ascertain information about the use of one or more resources linked to said communications network, said method comprising the steps of:

20 obtaining a data source for a first group of one or more monitored resources, said first group linked to said communications network;

obtaining a further data source for a second group of one or more monitored resources or a group of monitored users, each of said second group and said group of monitored users linked to said communications network and

25 combining said data source and said further data source to form a single data source available to interested parties so as to ascertain usage information on one or more resources.

The combining step may include one or more of displaying, aggregating, transforming, calibrating or formatting said single data source via a reporting server means through said communications network.

30

According to a second aspect of the invention there is provided a system for measuring and analysing multiple data sources over a communications network in order to ascertain information about the use of one or more resources linked to said communications network, said system comprising:

5 a first group of one or more monitored resources, comprising resource servers;

a second group of one or more monitored resources, comprising resource servers,

10 a data collection and processing means for receiving a data source for said first group of one or more monitored resources, and for receiving a further data source for said second group of one or more monitored resources; and

reporting means for displaying said data source and said further data source as a combined data source to interested parties so as to ascertain usage information on one or more resources.

15 According to a third aspect of the invention there is provided a system for measuring and analysing multiple data sources over a communications network in order to ascertain information about the use of one or more resources linked to said communications network, said system comprising:

20 a first group of one or more monitored resources, comprising resource servers;

a second group of one or more monitored users, comprising resource servers;

a data collection and processing means for receiving a data source for said first group of one or more monitored resources, and for receiving a further data source for said second group of one or more monitored users; and

25 reporting means for displaying said data source and said further data source as a combined data source to interested parties so as to ascertain usage information on one or more resources.

30 According to a fourth aspect of the invention there is provided a network enabling internet access by a user computer, characterised in that a connection means on the user computer may be set to enable connection between a proxy server and the user computer such that the proxy server is communicably coupled between

the connection means on the user computer and any internet site servers in order to monitor the internet usage of the user.

In this regard, the expression "connection means" is taken to refer to the means by which a user is provided with internet access, such as an internet browser.

5 Additionally, the user computer may be any means capable of receiving and displaying information from the internet, such as a set-top internet terminal.

According to a fifth aspect of the invention, there is provided a method of enabling research in a communications network having at least one user computer with an internet browser, the method comprising the step of:

10 altering a proxy setting of the browser of the user's computer to divert the user computer's internet access through a proxy server.

Therefore, by making a small change to the setting of a user's connection means/network browser at only one point in time, it is possible to analyse the user's network usage, without the need for installing any software, impacting on user time
15 or diverting their attention. This method also is able to overcome the measurement problems pertaining to resources stored in caches.

According to a sixth aspect of the invention there is provided an apparatus for measuring usage of internet resources, comprising:

a proxy server in communicable relation with a user browser, the
20 communicable relation effected via a proxy setting of the browser, such that the user browser is capable of accessing at least one internet resource via the proxy server, and the proxy server is capable of initiating usage measurement of the resource accessed.

According to a seventh aspect of the invention there is provided a method of
25 measuring usage of internet resources comprising the steps of:

enabling a user's browser proxy setting to reference the location of a proxy server;

receiving an internet resource request at the proxy server from the user's browser;

30 forwarding the resource request to a resource server to obtain the requested resource;

- 7 -

receiving the requested resource at the proxy server from the resource server;
and

passing the requested resource to the user's browser after the insertion of a measurement code to monitor the usage of the requested resource.

5 And finally according to an eighth aspect of the invention there is provided a system for measuring and analysing multiple data sources over a communications network in order to ascertain information about the use of one or more resources linked to said communications network, said system comprising:

a plurality of resource servers;

10 an insertion server linking each resource server of said plurality of resource servers to said communications network;

such that when a request for a monitored resource from any one of said resource servers is made, measurement code is inserted into said requested monitored resource by said insertion server for the purposes of measuring and
15 analysing usage of the monitored resource.

BRIEF DESCRIPTION OF THE DRAWINGS

The invention will be hereinafter described in one or more preferred
20 embodiments with reference to the accompanying drawings, wherein:

Figure 1 is a schematic diagram of a system for measuring and analysing data from data sources according to a first embodiment of the invention, particularly in relation to the use over the internet;

Figure 2 is a schematic diagram of a system for measuring and analysing data
25 from data sources according to a second embodiment of the invention, particularly in relation to accessing resources from WAP-enabled user interface devices;

Figure 3 is a schematic diagram of a system for measuring and analysing data from data sources according to a third embodiment of the invention, particularly in relation to using a digital television network.

Figure 4(a) is a schematic flow diagram showing the processes involved in measuring and obtaining various data sources generally in accordance with the invention;

Figure 4(b) is a schematic flow diagram showing the processes involved in measuring, obtaining and processing various data sources and applying results to extract data on unmonitored sources;

Figures 5(a) and 5(b) are block diagrams showing the processes involved with data when access is made to an unmonitored resource and a monitored resource;

Figure 6(a) is a schematic diagram of a system for measuring and analysing data from data sources according to a further embodiment of the invention using a proxy server;

Figure 6(b) is a schematic diagram of a system for measuring and analysing data from data sources according to another embodiment using an independent server; and

Figure 7 is a schematic diagram showing the processes involved in accessing a resource via a proxy server.

DETAILED DESCRIPTION

20

Shown in Figure 1 is a system 1 used to measure and analyse data in accordance with the present invention. Various users, having user interface means 10, 12, 14 and 16, are linked to a communications network 18 which also has links to various resource servers 2, 4, 6 and 8 through which the users can access resources. There is generally a plurality of user interface means which may include but is not limited to the following group: PCs, handheld devices such as mobile telephones or palmtops, television receivers or monitors or any user interface device capable or having information entered into, interacted with or viewed by the user. There may be a plurality of resource servers of which 2 to 8 are examples. The communications network 18 may be the Internet or a digital or analog television network or any circuit-switched or packet-switched network.

30

The embodiment shown in Figure 1 will be described with particular reference to the Internet and the measurement and analysis of data sources from monitored resource servers, for example servers 2 and 4, unmonitored resource servers, say servers 6 and 8, and browsers installed on the user interface means. One data source is measured using monitored resources. This data source may comprise site centric measurements such as census data or audit data, proxy or server log files, implemented using Java, JavaScript or CGI. The resources may be any one of a web page (to measure the number of accesses to the web page), time spent on a web site or web page, page impressions or a feature of a web page or web site that is interacted with by one or more users or offers the option of a response to the users. Resource owners agree to have their resources monitored to determine more information about the behaviour of users who access these resources. Measurement code, a form of program code, is embedded in for example every web page or embedded in each resource to be monitored. Every time a user accesses the monitored resource the measurement code in the downloaded resource records and collects information on that user and all such recordings for all users who access that resource are forwarded to a data collection and processing means 20. Every page could physically have code embedded therein or be dynamically inserted by another component, such as a separate server 130 (as shown in Figure 6(b)), on its path to the user. Specifically the data source from servers 2 and 4 is received by a first collection server means comprising one or more collection servers 22, 24. The abovementioned data source is then forwarded to a processing server means 30 for processing, formatting, etc and thereafter stored in data storage means 35. The stored data may then be accessed by a reporting server means 34 such that the data is displayed or manipulated in some manner when accessed by interested parties through the network 18. All of the server means 22, 24, 26, 28, 30, 32, 34 and 35 form part of a data collection and processing means 20 and each of the tasks performed by these server means may be performed by one individual server or a group of servers. For example, the collection servers and processing servers may be one and the same server.

With reference to Figure 6(b) an insertion server 130 may be used to forward all requests between the resource servers 2, 4 and 6 and the users 10, 12 and 14. Measurement code can be inserted by the insertion server 130 into each monitored resource requested from a respective resource server.

5 A further data source may be measured and analysed from a group of one or more monitored or participating users. A random sample of monitored users is recruited to form a panel from whom their interactions are measured and recorded in terms of accessing monitored and unmonitored resources, at the resource servers, via each user's browser, indicated by "B" in figure 1. The monitored users give
10 their permission to allow the monitoring and tracking of their actions or interactions and provide their personal details, such as where they live (region), sex, age, income, home or business user. Reliable statistics on Internet population data collected is used to determine preset demographic quotas for the recruitment process. These users should be demographically representative of the preset quotas,
15 according to such criteria as age, sex, income and whether or not the user is a business user or a private user.

The further data source may comprise user centric measurements including panel data, sample data, survey data. Each monitored user of the group (otherwise termed a "panellist") will have every page impression, web site access, or time spent
20 on a site or page or any other characteristic measured and recorded via measurement code which is downloaded together with the requested resource to the panellist's browser B. For example, then, if user interface means 10 and 12 are used by panellists each time they access or interact with monitored resources, at servers 2 and 4, and/or on unmonitored resources through servers 6 and 8, these are recorded
25 by a second collection server means comprising one or more collection servers 26, 28. Identification means is transmitted to the collection servers 26, 28 identifying the user, after each interaction is recorded, either through some form of identification means or cookies.

Processing server means 30 and 32 respectively receive the data source and
30 further data source to process the data. Thus processing server 32 processes data forwarded to it from the second collection server means. Examples of processing

- 11 -

include aggregating or formatting the data, or calibrating the data for a particular purpose. One example of processing the data sources includes calibrating them for a particular purpose, such as calculating an error rate to determine an estimate for interactions, such as page impressions, for an unmonitored site for which there is no site centric data available. At this stage the received further data sources, as processed by the processing servers 30 and 32 and subsequently stored in storage means 35, may be viewed or displayed by interested parties on reporting server 34. An example of the calibration process will hereinafter be described.

It is to be noted that the further data source may be of the same type as the first mentioned data source, that is, from monitored resources.

Weighting may be performed to the collected data source and further data source in each of the collection servers 22 to 28. This is performed by the processing servers 30 and 32. The weighting is done to adjust for the difference in demographic profiles of the sample or group to the population. The population weightings are obtained from pre-established internet population statistics for a certain time period. This step ensures that the collected data, after the weighting process, is representative of the Internet population of the measured geographical region. To derive greater accuracy a further breakdown of the official data showing the Internet population statistics may be performed into a combination of various groups or subjects. Such groups may include sex, age, current access method, income. Thus the collected data from page impressions from the sample users may be tabled in terms of each of the categories mentioned above to provide a more accurate picture to interested groups. Furthermore, the breakdown may be in terms of categories relating to the types of monitored resources, for example, sport, politics, entertainment, business.

There will be an overlap of the data source and further data source results where a monitored resource, having say site centric measurements available, has corresponding further data source results pertaining to panellists. Thus, for example, for a monitored web site there is panel data collected from each of the panellists for the same monitored web site. Comparable data is therefore taken from the two corresponding different sources, being panel data which may pertain

to various interactions performed by the panellists, and the abovementioned site centric measurements.

If, for example a panel or group of 3000 users are registered from which panel data is obtained, then a weighting function is applied to determine or estimate
5 actual traffic levels for all internet users in a particular region. For example in Australia, there is an estimated total internet audience of 4.4 million. Weighting is simply applied as a multiplication factor which brings the representative sample in line with the total traffic market trends, that is, $4,400,000/3000 = 1466.7$. All unique visitor numbers for sites or page impressions are multiplied or weighted by
10 this factor in order to estimate the actual traffic levels.

Of the 3000 users who are taking part in the panel, say 2000 users, visit a monitored web site (resource) from server 2 or perform particular interactions on that web site which has corresponding site centric measurements output available, and another 2500 panellists visit a web site that is not monitored, say at server 8. As
15 the other web site is not monitored then there is no site centric measurement data available and so to estimate the total traffic or users that would access the other web site or perform particular interactions on that web site or on a web page of that web site, the following occurs.

The 2000 users who have accessed the web site that is monitored, at server 2
20 is scaled up in accordance with the internet. Thus, we arrive at a figure of the total number of the internet audience being 4,400,000, divided by the number of panellists taking part in the sample, being 3000, and multiply this by 2000, which represents the number of panellists estimated to have actually visited that site. This results in an expected 2, 933,333.3 users in the internet population to visit this site
25 over the predefined period. This is the ideal situation where we would expect the numbers obtained, after scaling up, and the actual site centric measurements to correspond exactly. Equivalently, the number of users in the internet audience you would expect to visit the unmonitored site, at server 8 is $4,400,000/3000 \times 2500 = 3,666,666.6$ visits.

30 However, inherent in the sampling there are expected to be deviations and therefore calibration in terms of an error rate is introduced, being the ratio of the site

- 13 -

centric measurements to that of the equivalent panellist metrics. Separate metrics may be used to improve accuracy, such as one for page impressions, advertisement views, unique visitors, or other traffic measurements or other resource metrics. Each of the error rates are derived for the metrics for the particular period under
5 review.

Thus, for the above example, if the actual census data for the number of visits to the monitored web site is 3,200,000, then the actual deviation is $3,200,000/2,933,333.3$ which provides a ratio of 1.0909 so that the sample has an error rate of a factor of 0.0909. This ratio of 1.0909 is then multiplied by the
10 derived figure above (3,666,666.6) for the site that is not monitored which is equivalent to 4,000,000 visits or use of the attributes.

The above derived example related to using only one monitored site. However, similar or other techniques can be applied on a group of resources, such a number of web sites or advertising page impressions. Furthermore different metrics,
15 based on different requirements may need alternative calibrations, such metrics including page impressions, unique visitors or time measurement. The calibration may be based on two data sources or more than two data sources, whether they be from monitored or unmonitored resources.

Thus, by using the above method, sites that are not monitored can have
20 additional data available to them to estimate the amount of traffic which provides an invaluable resource to interested parties to specifically target users in respect of various activities or interactions that they have undergone in accessing a particular web site. Furthermore, it provides additional information to owners of monitored web sites as to how many visits or interactions/responses unmonitored web sites
25 (being potential competitors to such owners) have had from the internet audience, based on the two or more sources of data, from the site centric measurements and/or from the user centric measurements, or simply based on the site centric measurements. Thus more information is available about the behaviour of the internet population or audience.

30 In the abovementioned process, in order to produce comparable data, sites having site centric data collected are grouped into the same grouping of sites which

is made in the user centric data. Thereafter, the same groupings of URLs in the site centric and user centric groups are then formed. Naturally, the bigger this group accounts for in terms of the number of monitored resources or page impressions for example, the more accurate the end results are expected to be.

5 With reference to Figure 2, various users may have user interface means that are for example WAP-enabled processors such as a mobile telephone 40, linked to a cellular network 46 which in turn is linked to the internet 18 through a WAP gateway 48. Each of the WAP-enabled devices use the Wireless Mark-up Language (WML). Accesses to or interactions with a monitored resource are recorded by
10 embedding measurement code in the monitored resource and this is forwarded to collection servers 22, 24 of the data collection and processing means 20 as in the previous example. Those users forming part of a panel or group have corresponding interactions monitored whereby measurement code, as mentioned earlier, is downloaded with the requested resource(s) into the WAP-enabled devices to
15 monitor the actions or interactions of each of the users of the devices. Each of the interactions of the users are monitored and recorded by the measurement code for corresponding interactions on monitored and unmonitored resources and forwarded to collection servers 26, 28 of the data collection and processing means 20. Information in the form of reports may be displayed to interested parties after
20 combining the two separate sources of data, as processed by processing servers 30 and 32, on reporting server 34. Again, this follows the forwarding of the processed data from the processing servers 30, 32 to data storage means 35 which is accessed by the reporting server 34. Of particular interest, information about interactions of the various users for sites that are not monitored is available by previously
25 mentioned calibration techniques.

The above principles are easily adapted to Web television, whereby each of the devices 10, 12, 14 or 16 are television receivers such that users are monitored in terms of their responses or choices of options regarding a particular television program or television commercial. Thus there are a number of sample TV users
30 having respective television receivers accessing the internet and are monitored in terms of their responses or interactions on a particular resource server by the

- 15 -

abovementioned measurement code accompanying each of the resources being downloaded to each of the users' devices. For various resources the site centric measurement data is already available and there will be some resources that overlap with the recorded user centric data. Thus information pertaining to various interactions or actions by many users are obtainable for other sites that are not monitored which thereby provides a good comparison of resource usage, for example, of various web sites to interested parties.

With reference to Figure 3, there is shown a digital television network 50 to which are linked various television receivers 10, 12 and 14 that have users who have agreed to be part of a survey for monitoring their responses or actions for a particular resource such as a television program or commercial. There are also other users 54 who have digital television receivers for which no monitoring is conducted. A television station resource server 2 will transmit various programs or advertisements over the digital network 50 and for some programs will already have site centric measurement data, such as audit or census data available on all of the users (users on receivers 10, 12, 14 and 54) who view the program and make responses or actions where required regarding that program or advertisement. Again, a sample of users is used to obtain panel data by measurement means to each of the sample user receivers 10, 12 and 14 that can track their movements and actions in relation to other unmonitored corresponding advertisements or other unmonitored programs from different television networks, such as TV station resource servers 4 and 6, as well as the monitored programs from TV station resource server 2. All this information can be used to calibrate or check panel data for which interested parties such as users in the on-line industry or those in the television industry can receive reports through reporting server 34 on popular programs that are watched or advertisements that are responded to across the whole digital television user population. The abovementioned error rate is also applicable in determining numbers of users who respond to or interact in other ways with resources that are not monitored. The data collection and processing means 20 includes the first and second collection server means 22 to 28, processing servers 30 and 32, data storage means 35 and reporting server 34 to undertake similar tasks

- 16 -

as mentioned with respect to the embodiments described in Figures 1 and 2. Each of the collection servers and processing servers and the storage means 35 and reporting server 34 may be separate servers or function as one server unit. The data collection and processing means 20 may form part of a television station for calculating and collecting the data and the calibration applicable to unmonitored resources, such as other programs.

The medium in which the two data sources are obtained need not be the same. For example site centric measurement data may be obtained for internet based resources and be compared with or correlated with user centric measurement data for Web TV users or digital television users.

With reference to Figure 4(a), there is shown a number of steps used by the method and system of this invention in respect of any medium and resources thereof. Firstly, at step 60, a resource such as a web site or web page or television program, is monitored to determine and record all interactions with or accesses with the resource by all users having access to the resource.

A data source, such as site centric data, is obtained for one or more interactions at step 62 from all users who interact in some way with the monitored resource. This is recorded and collected by the collection servers 22,24 of the data collection and processing means 20. By way of example, the number of visits to a particular web page has may be recorded.

After establishing a panel or group of users, at step 64 these users are monitored for their interactions and at step 66 a second data source, such as panel data or any other form of data, is measured, recorded and collected by collection servers 26,28 of the data collection and processing means 20. The panel data may comprise for example page impressions or the number of visits each panellist has for the monitored resource, such as a web site and every unmonitored resource. At step 68, the two sets of data sources may be viewed, combined or otherwise customised on server 34.

In Figure 4(a) two or more data sources may be used for analysis, whether they originate from the same type of source, for example, monitored resources, or

from different types of sources, for example, one or more monitored resources and/or one or more unmonitored resources from monitored users.

In Figure 4(b), at step 70 resources are monitored, such as a web site access or page impression by all users and at step 72 a data source relating to site centric measurements is obtained for such web site accesses or page impressions. At step 5 74, pre-selected users are monitored for their interactions, corresponding to the monitored resource, for example the same web site accesses or page impressions and equivalently those same interactions of an unmonitored resource or resources. At step 76, the further data source relating to the above user centric measurements is 10 obtained and forwarded to the collection servers 26, 28. Collection servers 22, 24 will have the data from step 72. Processing servers 30, 32 calculate or calibrate an error rate based on the two sets of data at step 78 after scaling up has taken place and then at step 80 the error rate is applied to the unmonitored resource(s) from steps 74 and 76. Reports on the results may be displayed on server 34 for access by 15 users in the on-line industry after the processed data has been transferred to the storage means 35 from the processing servers 30, 32.

In Figure 5(a) there is shown processes used when a user's browser requests a monitored resource. The browser 80 first of all sends a request (81) for a monitored resource from resource server 82. The resource is sent back (83) from 20 the server 82 to the browser 80 with measurement code which was originally embedded. The measurement code monitors and collects information on the usage of the resource by the user and at (84) a record of this is sent to the respective collection server(s) 85. Thereafter the record can be processed together with other user or site centric measurements by the respective processing server(s) 87. Where 25 the user is a panellist, the measurement code would already have been sent to the panellist's browser and the interactions associated with a monitored or unmonitored resource recorded and sent to the respective collection server(s) 85. Thereafter it is processed by processing server(s) 87 and forwarded for storage to the data storage means 88. Reports may then be generated from the data storage means 88 to the 30 reporting server 89.

- 18 -

In Figure 5(b) there is shown process steps when a panellist requests an unmonitored resource. The user's browser 80 makes a request (91) for the unmonitored resource at the resource server 90 through the proxy server 100 which returns (92) the request to the browser 80 via the proxy server 100. The proxy server 100 inserts the measurement code into the requested resource before forwarding the request to the browser 80. Then the measurement code monitors and collects information on the usage of the unmonitored resource and forwards this at (93) to the collection server(s) 85, which is then collated as user centric measurement data. It may then be processed by processing server 87 and forwarded on to reporting server 89 via the storage means 88 as previously described. It is to be noted that the collection server(s) 85 may also be one and the same server as the proxy server 100.

Rather than obtaining measurements through browsers, or equivalently some program means loaded onto a user interface device, specific software may be loaded onto the devices 10, 12, 14 or a "hardware" box may be attached to the devices so that the user may be aware that he or she is being monitored. Alternatively, a proxy server may be used.

Where a proxy server is used, it is invisible to the user and enables an organisation or interested parties to monitor the internet usage of the panel member as an alternative to installing software or firmware onto the panel member's user interface. An advantage of the transparency of this tracking technique is that it promotes panel continuity.

In accordance with a further embodiment and with reference to Figure 6(a), resource requests and responses between user interface devices 10, 12 and 14 and the resource servers 2, 4 and 6 go through a proxy server 100. The proxy server may form part of the data collection and processing means 20.

Once a user has agreed to become a panel member, the user is instructed to change his or her browser setting to access the internet via the proxy server 100. If the user has trouble in effecting this set-up, they may e-mail a helpdesk provided by the organisation or access a call centre via telephone.

Examples of the manual proxy set-up process will now be described with reference to some existing Internet browsers.

If the user has Internet Explorer 4.0 or 5.0, to divert their internet access through a proxy server, they would be required to select "Internet Options" from their "View" menu, then "Connection Folder", followed by "Access the Internet using a proxy server". In the address entry box, they would enter the address of the proxy server, which would be provided to them by the research organisation.

Alternatively, if the user had Netscape 4.0, they would be required to select "Preferences" in the "Edit" menu of their browser, followed by "Advanced", "Proxies", "Manual Proxy Configuration" and "View". In the http: entry box they would then be required to enter the address of the proxy server, as provided by the party initiating the network measurement.

As an alternative to the manual set-up process, a software program may be used to effect the browser setting change: for example, the user could click on a link, and the link would then implement the change.

With reference to Figure 7, when a user requests a resource on their browser 110, the request first goes (112) to the proxy server 100. The request is then forwarded (114) by the proxy server 100 to the corresponding resource server 116. The resource server passes (118) the requested resource to the proxy server 100 and from there (120) the measurement code is embedded in the requested resource, at the proxy server 100 before it goes back to the user's browser 110 to record the interactions of the user. A record of this request is then sent (122) to the collection server of the data collection and processing means 20 for processing as part of the data source, where site centric measurements are collected for this particular user and other users in respect of similar resource requests. If the data relates to the further data source whether monitored or unmonitored, for example panel data of a panellist, like user centric measurements, then this procedure is repeated but the data is collected by the respective collection server 26, 28. It is to be noted that the collection servers 22 to 28 and the proxy server 100 may be the same server.

Thus, for some monitored resources there will be an overlap of site and user centric measurements for which data may be displayed separately or combined on

reporting server 34. Alternatively an estimate of traffic data can be determined for those unmonitored resources having no site centric measurements available, using the aforementioned techniques.

When the access request is diverted to the proxy server 100, the panel member is able to be identified by virtue of an identification means such as user ID or a unique cookie assigned to the member during the sign up process. A cookie is a feature of the internet protocol Hypertext Transfer Protocol (HTTP), which is essentially a unique identifier stored on the user's computer.

During the processing of the data it is possible to check for any anomalous usage of sites (eg. One user visiting a particular site fifty times in one day), that may not be representative of the overall sample of panellists. If it finds anomalies like this, the particular data may then be disregarded.

When recording interactions of a panel of users at the data collection and processing means 20, a view of internet usage by the "panel population" is able to be obtained. The data obtained via this panel approach may be used in isolation to obtain relevant statistics. Alternatively, as previously mentioned, a fusion of the panel data with site centric measurement data such as from browser based data or proxy or server logs may be used. In this alternative way, it is possible to fill the reporting properties or interactions of resources for which accurate site centric measurement data is not available, in order to improve the overall market measurement accuracy.

The user details should be periodically validated, so from time to time the users should be contacted to confirm participation and verify personal details.

Variations and additions are possible within the general inventive concept as will be apparent to those skilled in the art. In particular, if a user's browser or interface device does not support Java, alternative approaches for obtaining measurement data are possible and within the inventive concept, such as via CGI (Common Gateway Interface) measurement.

CLAIMS:

1. A method of measuring and analysing multiple data sources over a communications network in order to ascertain information about the use of one or more resources linked to said communications network, said method comprising the steps of:
- 5 obtaining a data source for a first group of one or more monitored resources, said first group linked to said communications network;
- obtaining a further data source for a second group of one or more monitored resources or a group of monitored users, each of said second group and said group of monitored users linked to said communications network and
- 10 combining said data source and said further data source to form a single data source available to interested parties so as to ascertain usage information on one or more resources.
- 15
2. A method according to claim 1 wherein said combining step includes one or more of displaying, aggregating, transforming, calibrating or formatting said single data source via a reporting server means through said communications network.
- 20 3. A method according to claim 1 or claim 2 such that when said further data source is obtained with respect to said group of monitored users, the method further comprises the step of initially forming said group of monitored users as a sample group so as to record and measure interactions of users in said sample group.
- 25 4. A method according to claim 3 wherein the interactions of the users in the sample group are entered by the users in a user interface means.
5. A method according to claim 3 or claim 4 wherein the further data source is based on said interactions in relation to one or more monitored resources and/or one or more unmonitored resources.
- 30

- 22 -

6. A method according to any one of claims 1, 2 or 5 further comprising the step of processing said data source and said further data source.
7. A method according to claim 6, when appended to claim 5, wherein the processing of said further data source is in relation to the interactions of the users in said sample group and further comprises calibrating a value based on said data source and said further data source.
8. A method according to claim 7 wherein said calibrating step comprises calculating an error rate.
9. A method according to claim 8 further comprising the step of applying the error rate to the further data source of one or more unmonitored resources so as to determine an estimate of equivalent interactions of total users with respect to the one or more unmonitored resources.
10. A method according to any one of the previous claims wherein the step of obtaining said data source uses measurement code means from said first group to obtain measurements of said interactions of all users of said first group of one or more monitored resources.
11. A method according to claim 3 wherein the step of obtaining said further data source uses measurement code means forwarded to each user interface means of users in said sample group so as to record all interactions of each user in the sample group.
12. A method according to claim 9 further comprising the step of calculating a weighting factor based on the number of users in said sample group and the total number of users expected to have access to one or more resources available through said communications network.

13. A method according to claim 12 further comprising the step of multiplying said weighting factor with the number of users in said sample group that have interactions recorded in relation to said first group of one or more monitored resources to obtain a first figure for the expected number from all users to have interactions with said first group.

14. A method according to claim 13 further comprising the step of multiplying said weighting factor with the number of users in said sample group that have corresponding interactions recorded in relation to said one or more unmonitored resources to obtain a second figure for the expected number from all users to have recorded interactions of the one or more unmonitored resources.

15. A method according to claim 14 wherein the error rate is calculated by dividing the number of actual interactions in said data source, pertaining to the one or more monitored resources in said first group, by said first figure.

16. A method according to claim 15 wherein the calculated error rate is multiplied by said second figure to obtain the expected number of total users to have interactions in relation to said one or more unmonitored resources.

17. A system for measuring and analysing multiple data sources over a communications network in order to ascertain information about the use of one or more resources linked to said communications network, said system comprising:

a first group of one or more monitored resources, comprising resource servers;

a second group of one or more monitored resources, comprising resource servers,

a data collection and processing means for receiving a data source for said first group of one or more monitored resources, and for receiving a further data source for said second group of one or more monitored resources;

reporting means for displaying said data source and said further data source as a combined data source to interested parties so as to ascertain usage information on one or more resources.

5 18. A system for measuring and analysing multiple data sources over a communications network in order to ascertain information about the use of one or more resources linked to said communications network, said system comprising:

a first group of one or more monitored resources, comprising resource servers;

10 a second group of one or more monitored users;

a data collection and processing means for receiving a data source for said first group of one or more monitored resources, and for receiving a further data source for said second group of one or more monitored users;

15 reporting means for displaying said data source and said further data source as a combined data source to interested parties so as to ascertain usage information on one or more resources.

19. A system according to claim 17 or claim 18 wherein said reporting means is a reporting server means included in said data collection and processing means.

20

20. A system according to any one of claims 17 to 19 wherein said data collection and processing means includes collection server means for collecting said data source and said further data source and further includes processing means for processing the data source and further data source collected by the collection server means.

25

21. A system according to claim 18 wherein in relation to said further data source for said second group of monitored users, interactions and resource requests of each of the monitored users, entered on respective user interface means, are measured and recorded and sent to collection server means in said data collection and processing means.

30

22. A system according to claim 21 wherein the further data source is based on interactions from said monitored users in relation to one or more monitored resources and/or one or more unmonitored resources.

5 23. A system according to claim 22 wherein said further data source and said data source collected by said collection server means are processed by processing server means in said data collection and processing means to calibrate a value based on said data source and said further data source.

10 24. A system according to claim 23 wherein the calibrated value is an error rate which is subsequently applied to the further data source of one or more unmonitored resources so as to determine an estimate of equivalent interactions of total users with respect to the one or more unmonitored resources.

15 25. A system according to claim 24 wherein said processing server means calculates a weighting factor based on the number of users in the second group of one or more monitored users and the total number of users expected to have access to one or more resources available through said communications network.

20 26. A system according to claim 25 wherein said processing server means multiplies said weighting factor with the number of users in said second group of one or more monitored users that have interactions recorded in relation to said first group of one or more monitored resources to obtain a first figure for the expected number from all users to have interactions with said first group.

25

27. A system according to claim 26 wherein said processing server means multiplies said weighting factor with the number of users in said group of monitored users that have corresponding interactions recorded in relation to said one or more unmonitored resources to obtain a second figure for the expected number from all
30 users to have recorded interactions of the one or more unmonitored resources.

- 26 -

28. A system according to claim 27 wherein the error rate is calculated by dividing the number of actual interactions in said data source, pertaining to the one or more monitored resources in said first group, by said first figure.

5 29. A system according to claim 28 wherein the calculated error rate is multiplied by said second figure to obtain an expected number of total users to have interactions in relation to said one or more unmonitored resources.

10 30. A system according to claim 29 wherein said reporting server means displays said expected number of total users having interactions associated with said one or more unmonitored resources.

31. A system according to any one of claims 17 to 30 wherein said communications network is the Internet.

15

32. A method according to any one of claims 1 to 16 wherein said communications network is the Internet.

20 33. A system according to claim 21 wherein all requests for resources from the monitored users is done through a proxy server.

34. A system according to claim 33 wherein measurement code is inserted by said proxy server into one or more requested resources and then forwarded with the requested resource to the respective monitored user.

25

35. A system according to claim 34 wherein the proxy server is part of the data collection and processing means.

30 36. A system according to claim 17 wherein an insertion server means is used to insert measurement code into each resource requested by a user.

37. A method of enabling research in a communications network having at least one user computer with an internet browser, the method comprising the step of: altering a proxy setting of the browser of the user's computer to divert the user computer's internet access through a proxy server.

5

38. The method of claim 37 further comprising the step of upon receiving an internet resource requested by the user from a visited internet site, inserting measurement code into the resource requested and passing the resource to the user's browser to monitor the usage of the resource.

10

39. The method of claim 38 further comprising the step of passing measurement data, which includes user identification data, from the user's browser to a data collection and processing means.

15

40. A network enabling internet access by a user computer, characterised in that a connection means on the user computer may be set to enable connection between a proxy server and the user computer such that the proxy server is communicably coupled between the connection means on the user computer and any internet site servers in order to monitor the internet usage of the user.

20

41. The network of claim 40 wherein the connection means is an internet browser.

42. An apparatus for measuring usage of internet resources, comprising:

25

a proxy server in communicable relation with a user browser, the communicable relation effected via a proxy setting of the browser, such that the user browser is capable of accessing at least one internet resource via the proxy server, and the proxy server is capable of initiating usage measurement of the resource accessed.

30

43. The apparatus of claim 42 further comprising a measurement code that is inserted into an accessed resource by the proxy server prior to the resource being

forwarded to the user browser for measurement of the usage of that resource on the user browser.

44. The apparatus according to claim 42 or 43 wherein measurement data including user identification data is passed from the user's browser to a data collection and processing means

45. A method of measuring usage of internet resources comprising the steps of: enabling a user's browser proxy setting to reference the location of a proxy server; receiving an internet resource request at the proxy server from the user's browser; forwarding the resource request to a resource server to obtain the requested resource;

receiving the requested resource at the proxy server from the resource server; passing the requested resource to the user's browser after the insertion of a measurement code to monitor the usage of the requested resource.

46. The method of claim 45 further comprising the step of identifying the user at the data collection and processing means via an identification means sent with the measurement data.

20

47. The method of claim 46 wherein the identification means is a cookie.

48. The method of claim 49 wherein the measurement means is embedded code in an HTML page.

25

49. A system for measuring and analysing multiple data sources over a communications network in order to ascertain information about the use of one or more resources linked to said communications network, said system comprising: a plurality of resource servers;

an insertion server linking each resource server of said plurality of resource servers to said communications network;

30

- 29 -

such that when a request for a monitored resource from any one of said resource servers is made, measurement code is inserted into said requested monitored resource by said insertion server for the purposes of measuring and analysing usage of the monitored resource.

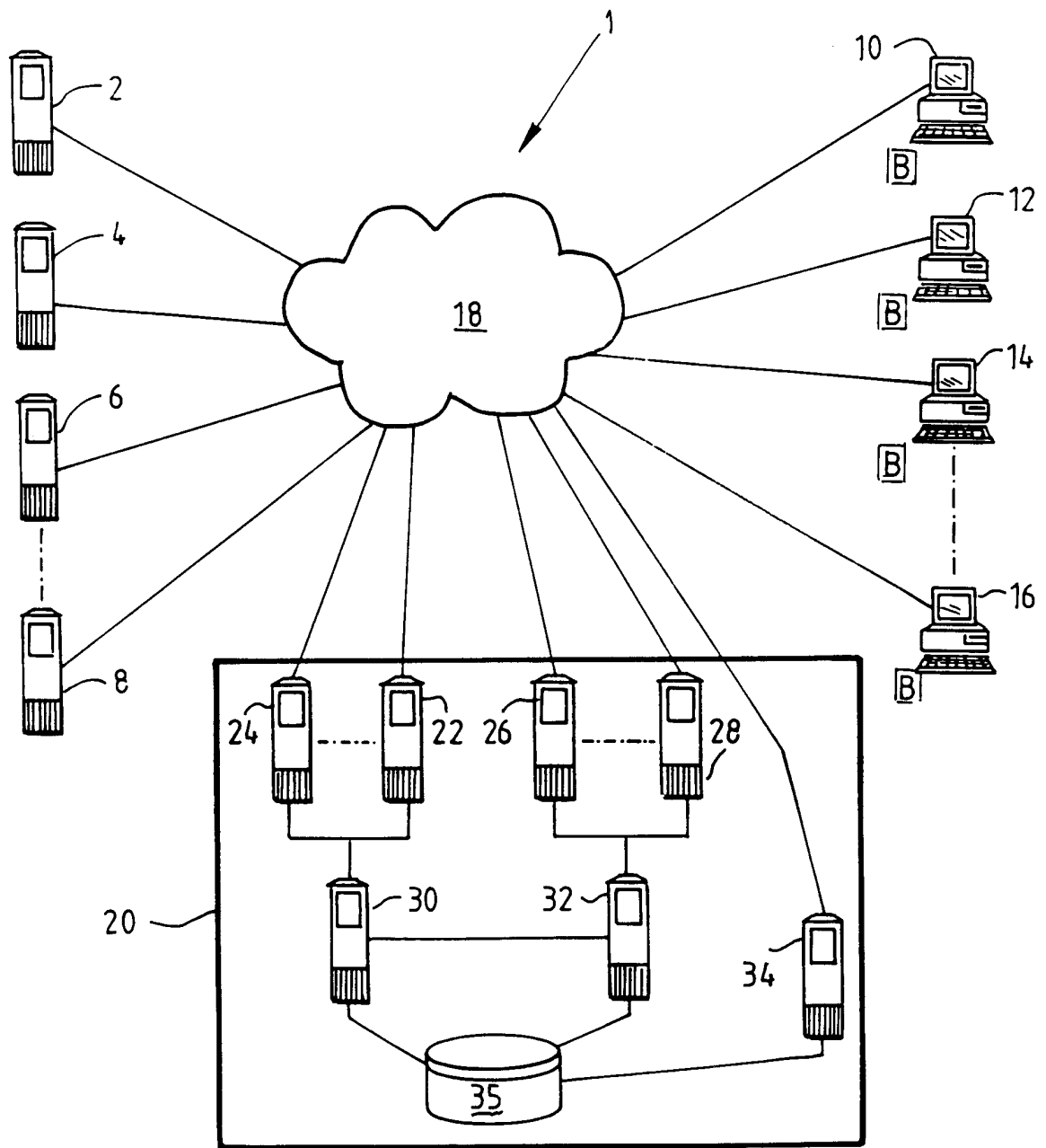

FIG. 1.

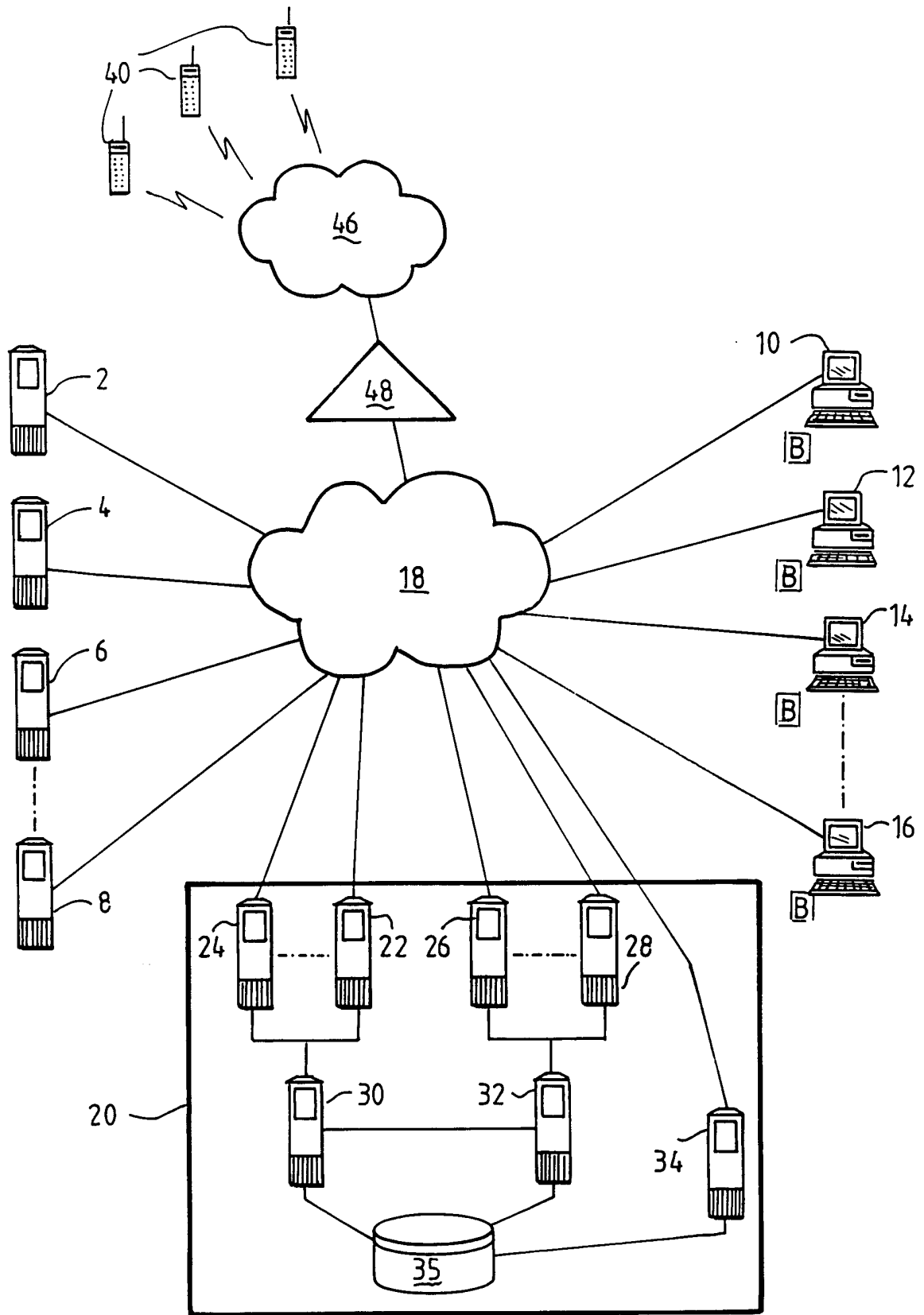
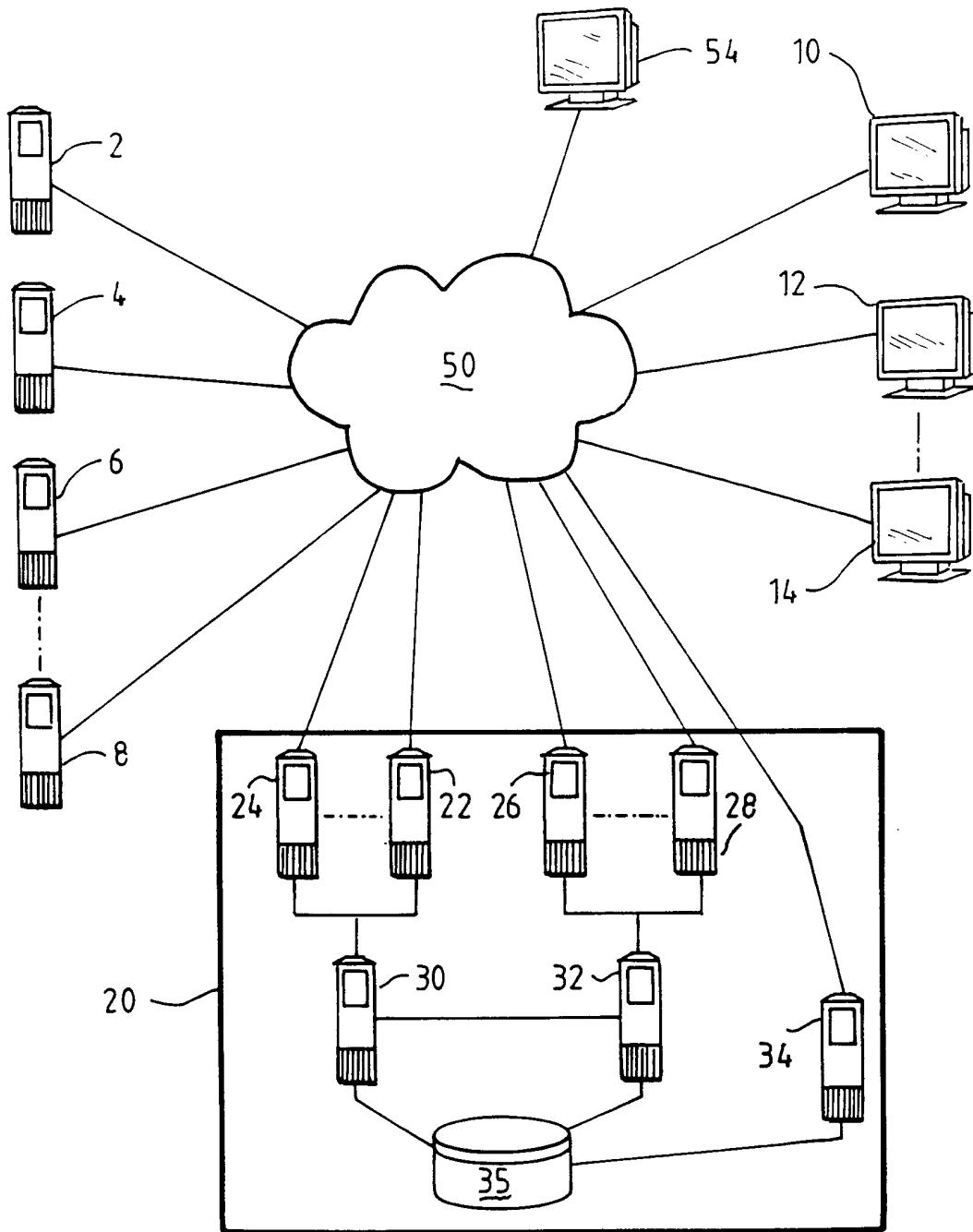

FIG. 2.



III.3.

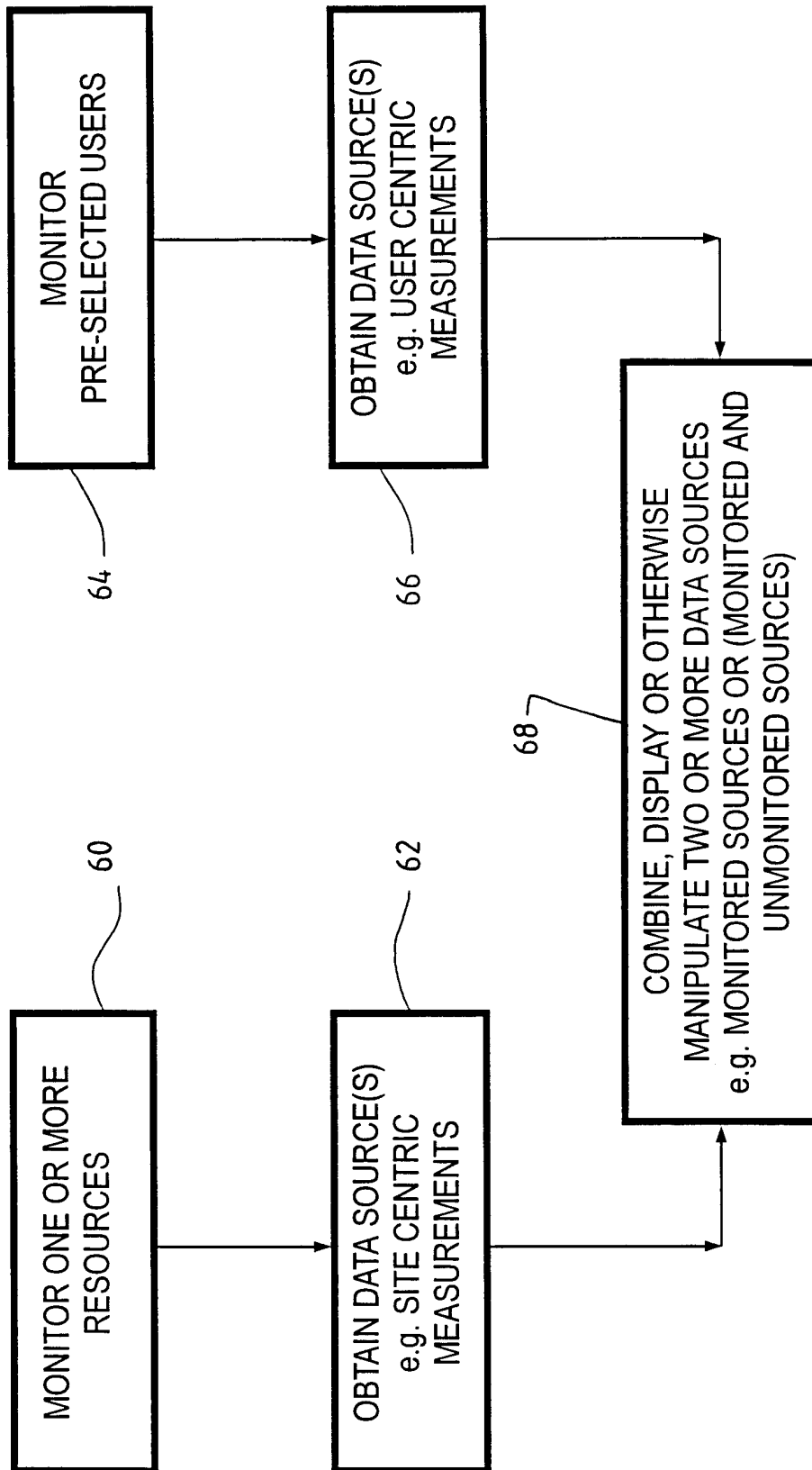
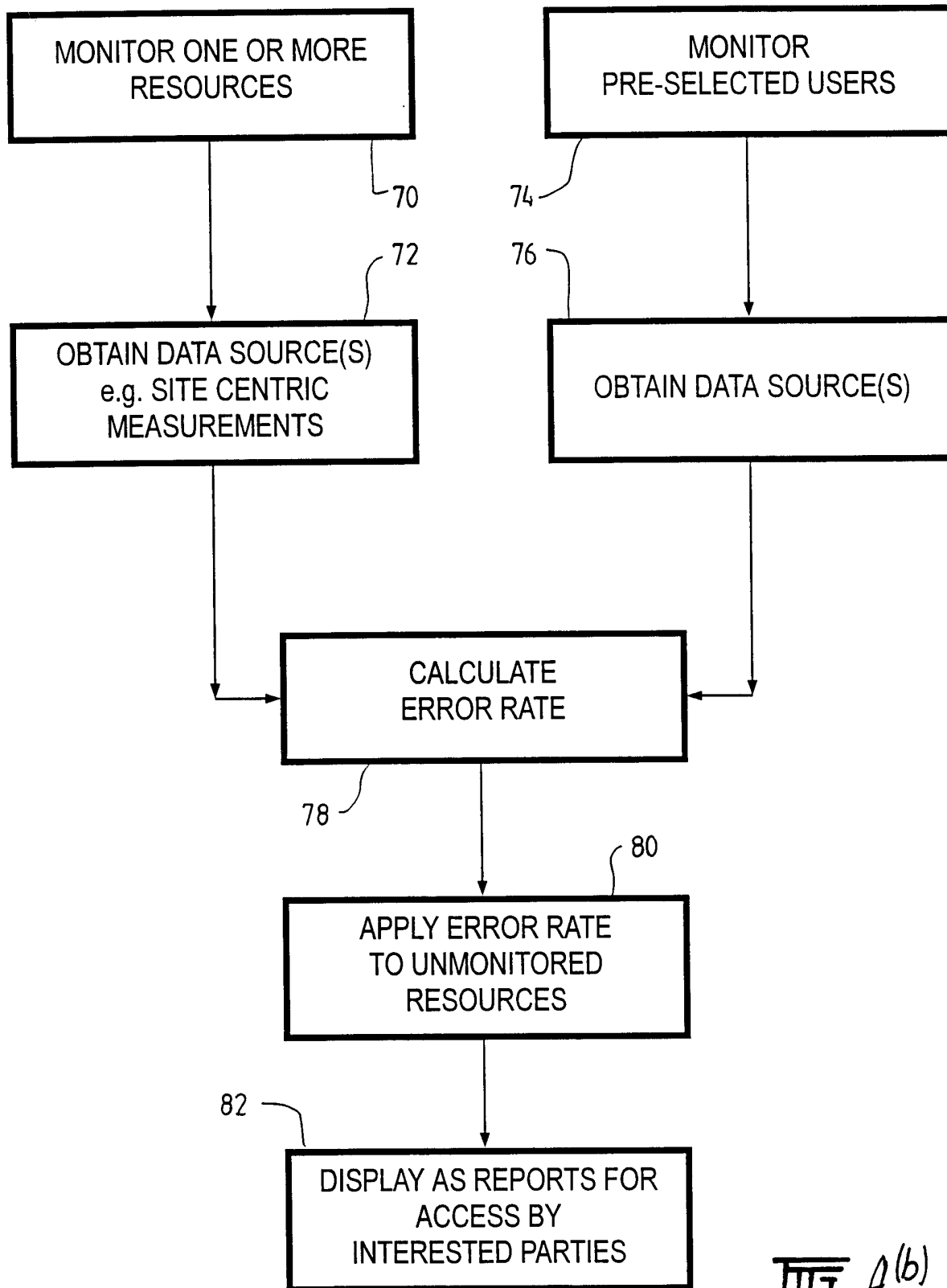

FIG. 4(a)



III 4(b)

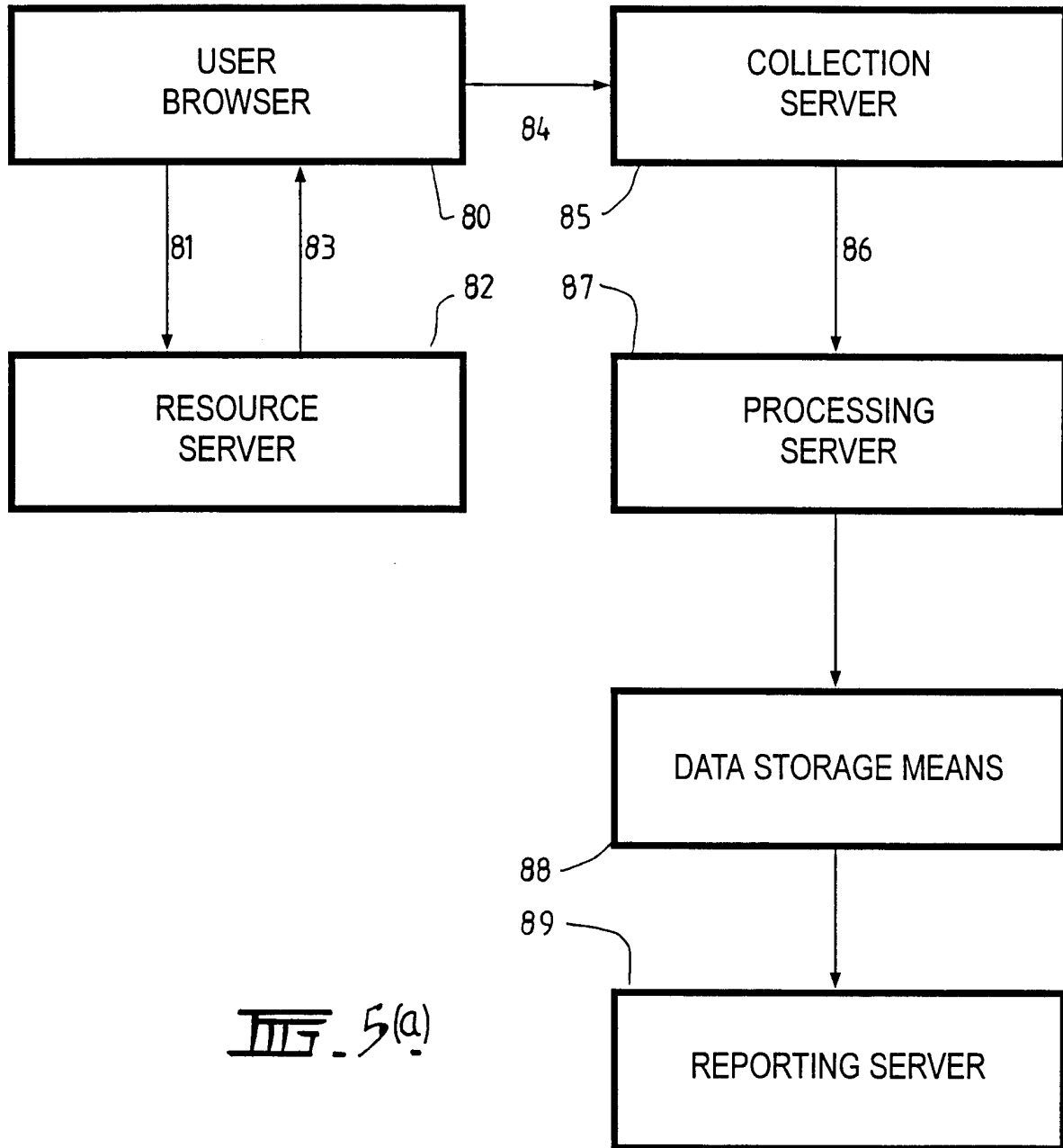

FIG. 5(a)

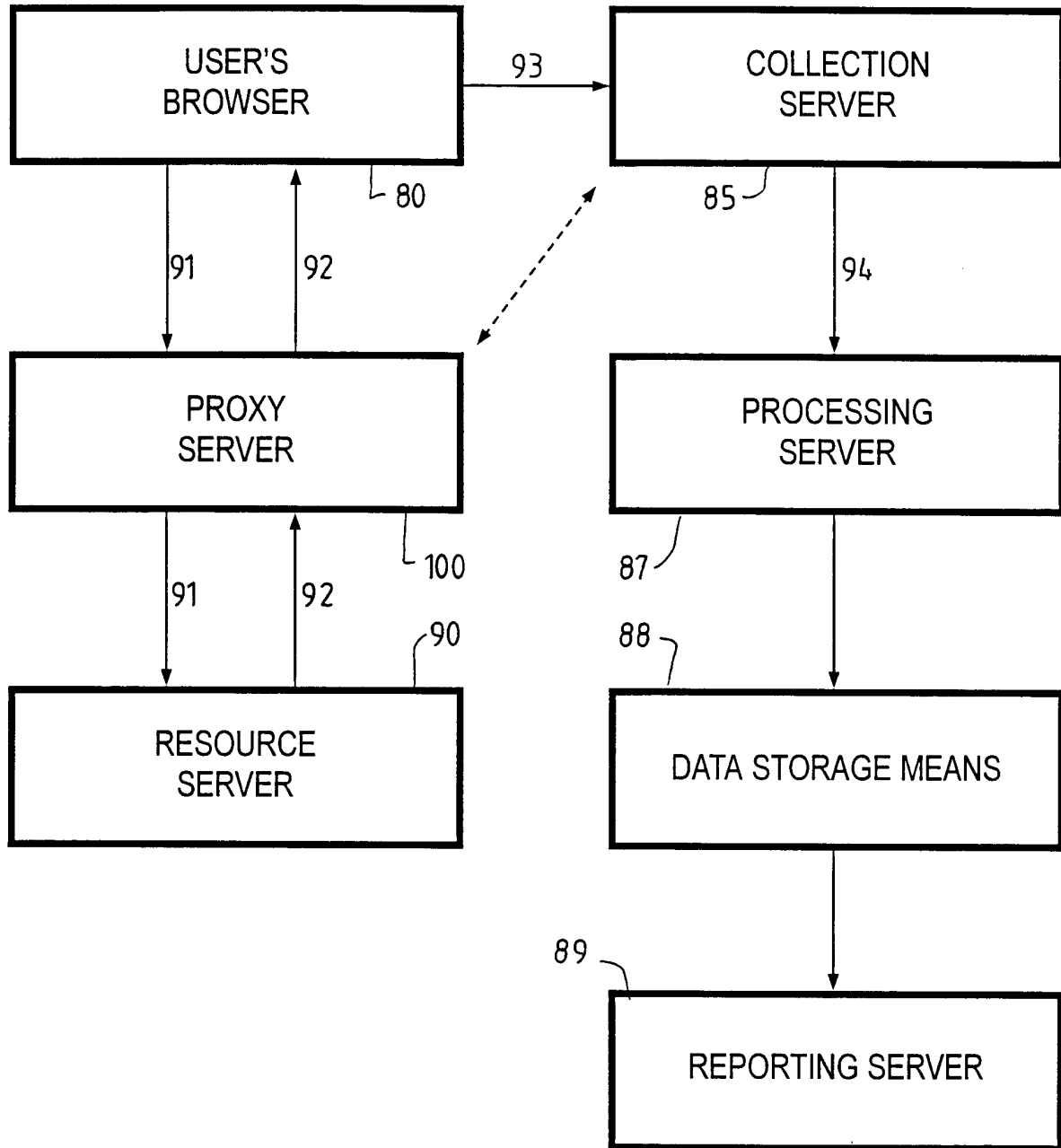

FIG. 5(b)

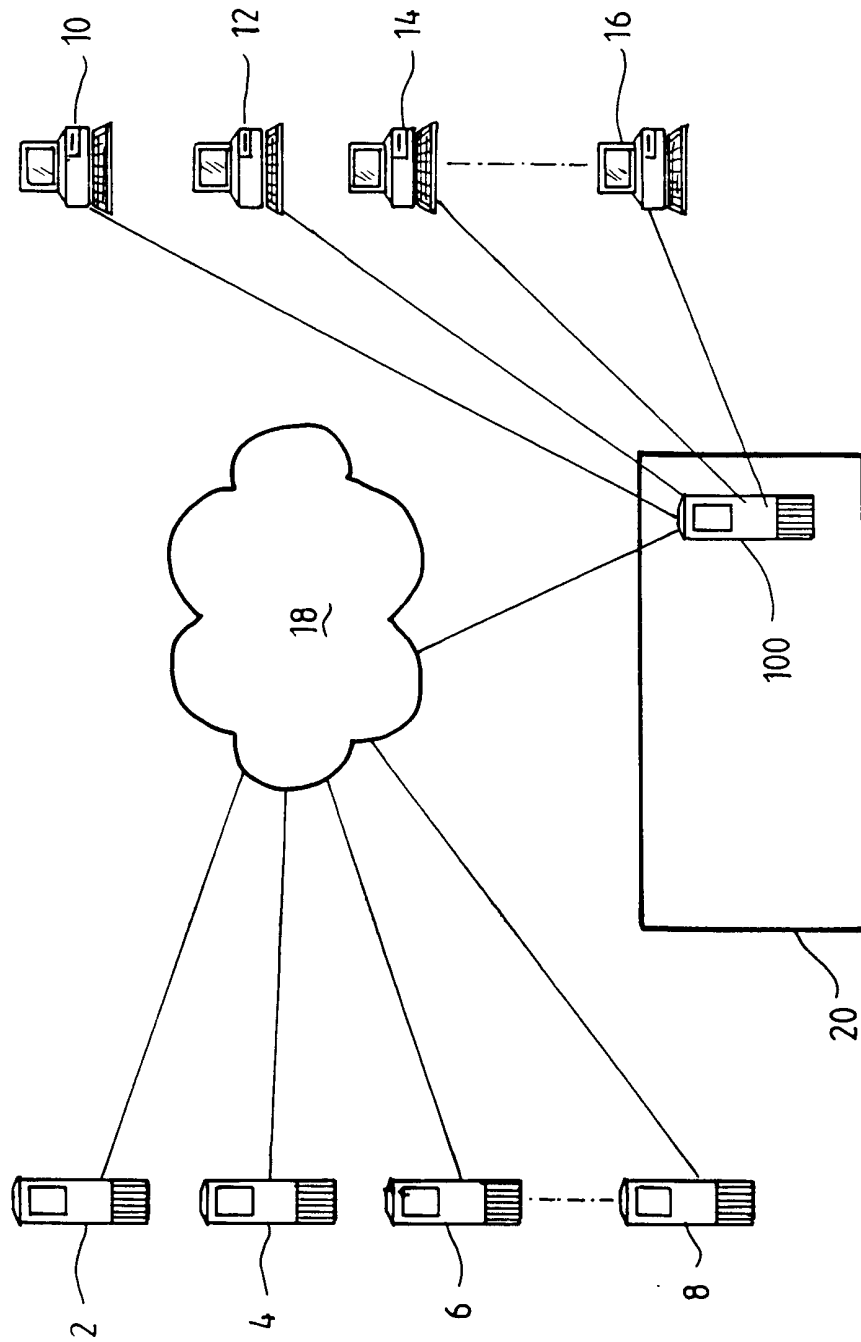

FIG. 6(a)

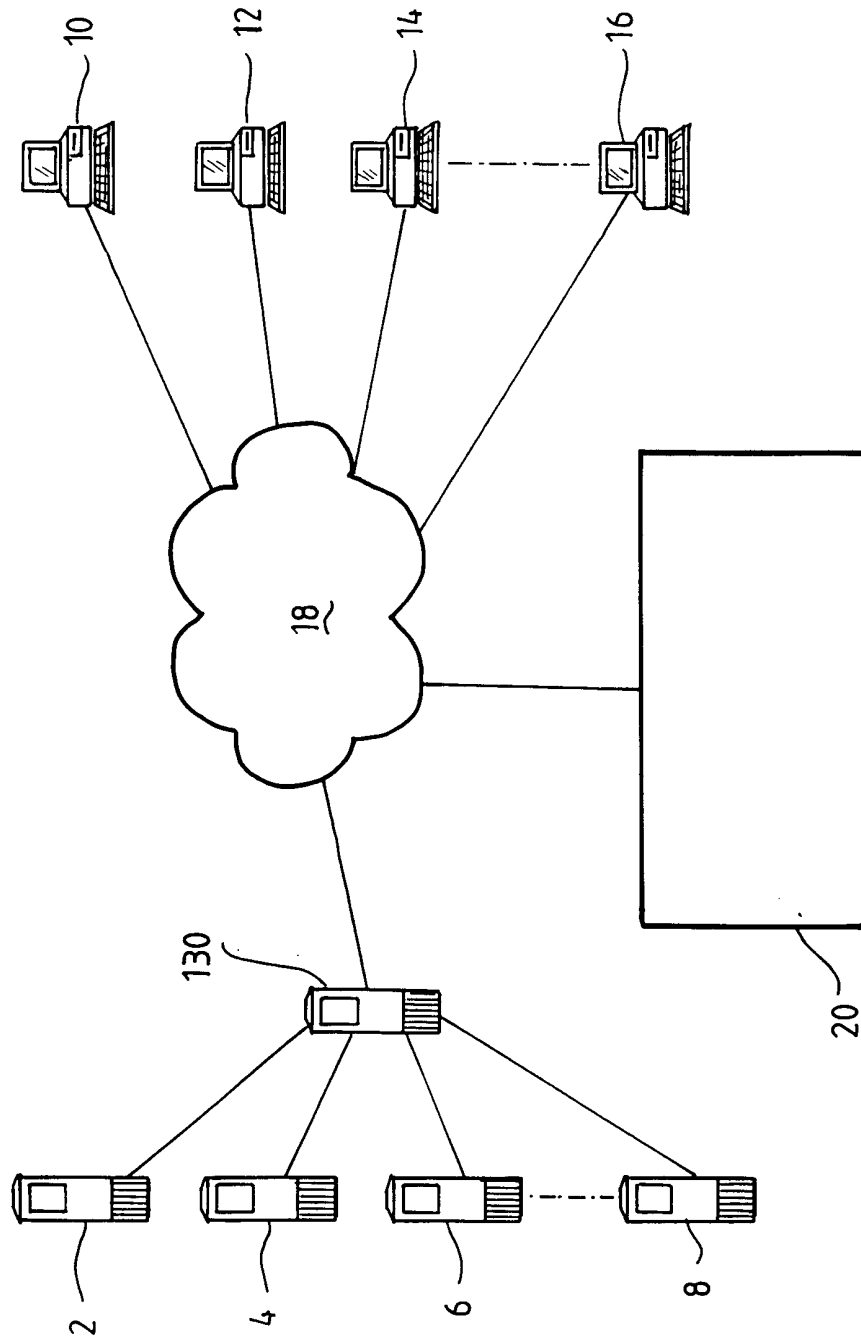

FIG. 6 (b)

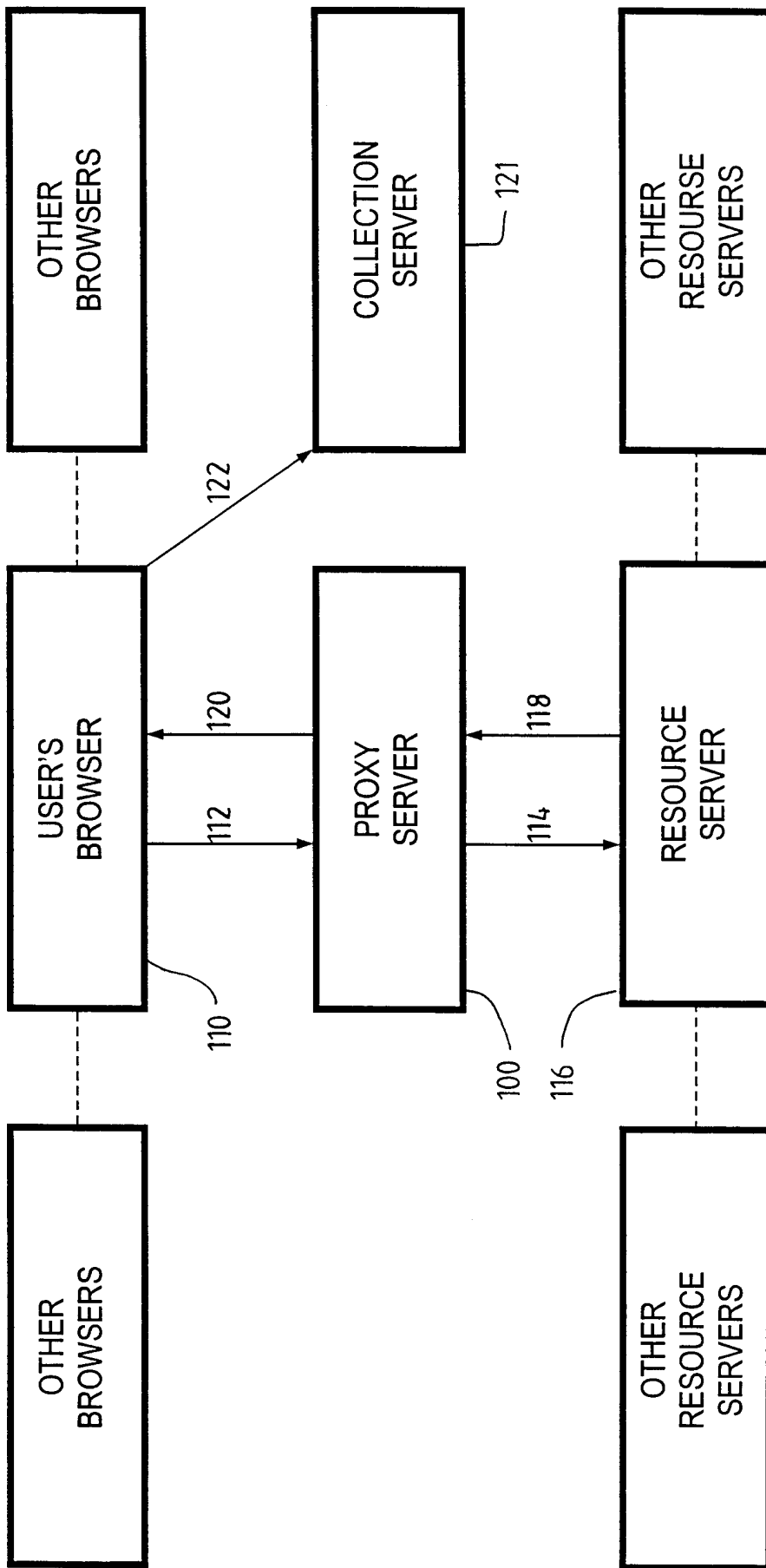

FIG. 7.

INTERNATIONAL SEARCH REPORT

International application No.
PCT/AU00/00937

A. CLASSIFICATION OF SUBJECT MATTER

Int. Cl. 7: G06F 17/40, 17/60, H04L 12/66

According to International Patent Classification (IPC) or to both national classification and IPC

B. FIELDS SEARCHED

Minimum documentation searched (classification system followed by classification symbols)
IPC: AS ABOVE

Documentation searched other than minimum documentation to the extent that such documents are included in the fields searched

Electronic data base consulted during the international search (name of data base and, where practicable, search terms used)
WPAT, IEEE, Internet (web, usage, monitor+, track+)

C. DOCUMENTS CONSIDERED TO BE RELEVANT

| Category* | Citation of document, with indication, where appropriate, of the relevant passages | Relevant to claim No. |
|-----------|------------------------------------------------------------------------------------------------------------------------------------|----------------------------|
| P,X | US 6 018 619 (Allard et al.) 25 January 2000 Column 5, lines 56-63, column 6, lines 8-12, column 7, lines 21-35 | 1,2,6,17-23,31-33,40-42,44 |
| X | US 5 931 912 (Wu et al.) 3 August 1999 Abstract, column 6, lines 48-50 | 1 |
| X | US 5 796 952 (Davis et al.) 18 August 1998 Whole document, esp. column 12, lines 39-50, column 15, line 59 to column 16, line 9 | 1,2,6,17-23,31-33,40-42,44 |

Further documents are listed in the continuation of Box C See patent family annex

| | |
|---------------------------------------------------------------------------------------------------------------------------------------------------------------------------------------------------------------------------------------------------------------------------------------------------------------------------------------------------------------------------------------------------------------------------------------------------------------------------------------------------------------------------------------------------------------------------------------------------------------------------------------------------|-----------------------------------------------------------------------------------------------------------------------------------------------------------------------------------------------------------------------------------------------------------------------------------------------------------------------------------------------------------------------------------------------------------------------------------------------------------------------------------------------------------------------------------------------------------------------------------------------------------------------------------------------------------------------------------------------------------------|
| <p>* Special categories of cited documents:</p> <p>"A" document defining the general state of the art which is not considered to be of particular relevance</p> <p>"E" earlier application or patent but published on or after the international filing date</p> <p>"L" document which may throw doubts on priority claim(s) or which is cited to establish the publication date of another citation or other special reason (as specified)</p> <p>"O" document referring to an oral disclosure, use, exhibition or other means</p> <p>"P" document published prior to the international filing date but later than the priority date claimed</p> | <p>"T" later document published after the international filing date or priority date and not in conflict with the application but cited to understand the principle or theory underlying the invention</p> <p>"X" document of particular relevance; the claimed invention cannot be considered novel or cannot be considered to involve an inventive step when the document is taken alone</p> <p>"Y" document of particular relevance; the claimed invention cannot be considered to involve an inventive step when the document is combined with one or more other such documents, such combination being obvious to a person skilled in the art</p> <p>"&" document member of the same patent family</p> |
|---------------------------------------------------------------------------------------------------------------------------------------------------------------------------------------------------------------------------------------------------------------------------------------------------------------------------------------------------------------------------------------------------------------------------------------------------------------------------------------------------------------------------------------------------------------------------------------------------------------------------------------------------|-----------------------------------------------------------------------------------------------------------------------------------------------------------------------------------------------------------------------------------------------------------------------------------------------------------------------------------------------------------------------------------------------------------------------------------------------------------------------------------------------------------------------------------------------------------------------------------------------------------------------------------------------------------------------------------------------------------------|

| | |
|--------------------------------------------------------------------------------------|--------------------------------------------------------------------------|
| Date of the actual completion of the international search 7 September 2000 | Date of mailing of the international search report 13 SEP 2000 |
|--------------------------------------------------------------------------------------|--------------------------------------------------------------------------|

| | |
|----------------------------------------------------------------------------------------------------------------------------------------------------------------------------------------|---------------------------------------------------------------------------------|
| Name and mailing address of the ISA/AU AUSTRALIAN PATENT OFFICE PO BOX 200, WODEN ACT 2606, AUSTRALIA E-mail address: pct@ipaaustralia.gov.au Facsimile No. (02) 6285 3929 | Authorized officer DALE E. SIVER Telephone No : (02) 6283 2196 |
|----------------------------------------------------------------------------------------------------------------------------------------------------------------------------------------|---------------------------------------------------------------------------------|

INTERNATIONAL SEARCH REPORT

International application No.
PCT/AU00/00937

| C (Continuation). DOCUMENTS CONSIDERED TO BE RELEVANT | | |
|--------------------------------------------------------------|-----------------------------------------------------------------------------------------------------------------------------------------------------------------------------------------------------|--------------------------------|
| Category* | Citation of document, with indication, where appropriate, of the relevant passages | Relevant to claim No. |
| X | WO 98/26529 (Nielsen Media Research Inc.) 18 June 1998 Whole document , esp. page 9 line 6-12 | 1-7,10,11,17-23,31-33,40-42,44 |
| P,Y | US 6 112 240 (Pogue et al.) 29 August, 2000 Whole document | 1,2,6,17-23,31-33,40-42,44 |
| Y | US 5 819 285 (Damico et al.) 6 October 1998 Abstract,figures | 1 |
| Y | US 5 819 156 (Belmont) 6 October 1998 Abstract,figures | 1 |
| Y | "Web mining: information and pattern discovery on the World Wide Web" (Cooley et al.) IEEE Int. Conf. on Tools with Artificial Intelligence, 3-8 Nov.1997 pp558-567 see section 5 on WEBMINER | 1 |
| A | US 5 787 253 (McCreery et al.) 28 July 1998 Abstract,figures | 1 |

INTERNATIONAL SEARCH REPORT

Information on patent family members

International application No.
PCT/AU00/00937

This Annex lists the known "A" publication level patent family members relating to the patent documents cited in the above-mentioned international search report. The Australian Patent Office is in no way liable for these particulars which are merely given for the purpose of information.

| Patent Document Cited in Search Report | | Patent Family Member | | | | | |
|----------------------------------------|----------|----------------------|----------|----|----------|----|---------|
| US | 5796952 | AU | 65731/98 | CN | 1251669 | EP | 1010116 |
| | | WO | 98/43380 | | | | |
| WO | 98/26529 | AU | 52668/98 | CN | 1253692 | EP | 944991 |
| US | 5819285 | AU | 73799/96 | WO | 97/13330 | | |
| END OF ANNEX | | | | | | | |