



US 20050079924A1

(19) **United States**

(12) **Patent Application Publication**  
**Heinecke**

(10) **Pub. No.: US 2005/0079924 A1**

(43) **Pub. Date: Apr. 14, 2005**

(54) **[WET WEATHER GOLF CLUB GRIP COVER]**

**Publication Classification**

(75) **Inventor: Mathew Frederick Heinecke,**  
Hillsboro, OR (US)

(51) **Int. Cl.7** ..... **A63B 53/14**

(52) **U.S. Cl.** ..... **473/300**

Correspondence Address:  
**MATHEW F. HEINECKE**  
**2323 NW 188TH AVE #2525**  
**HILLSBORO, OR 97124 (US)**

(57) **ABSTRACT**

A golf club grip cover which provides added friction between a golfers hand and the golf club grip during wet weather playing conditions. The cover has a cylindrical sock-like tube in shape, closed at the top end and open at the bottom end with a slit half of the way up the side from the bottom of the opening. The inside and outside corners of the opening cuff utilizes a hook and loop type of fastener to hold the cover in place and allow for ease of removal and attachment.

(73) **Assignee: Mathew Frederick Heinecke,** Hillsboro, OR (US)

(21) **Appl. No.: 10/605,608**

(22) **Filed: Oct. 13, 2003**

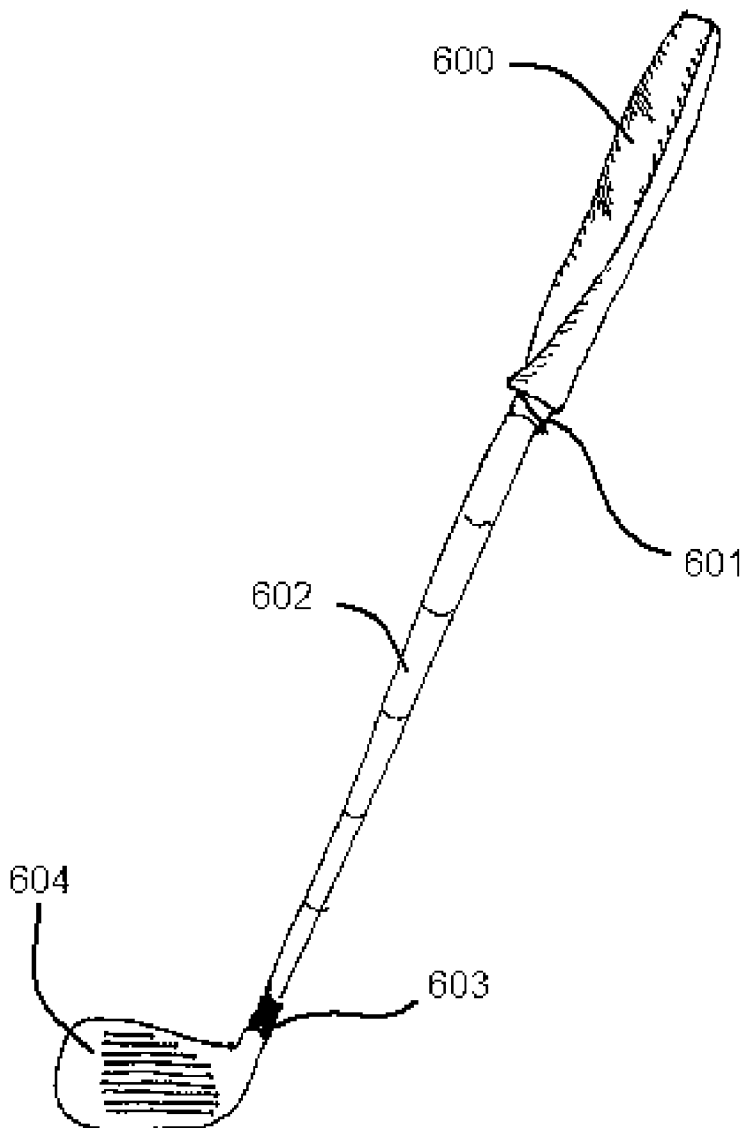

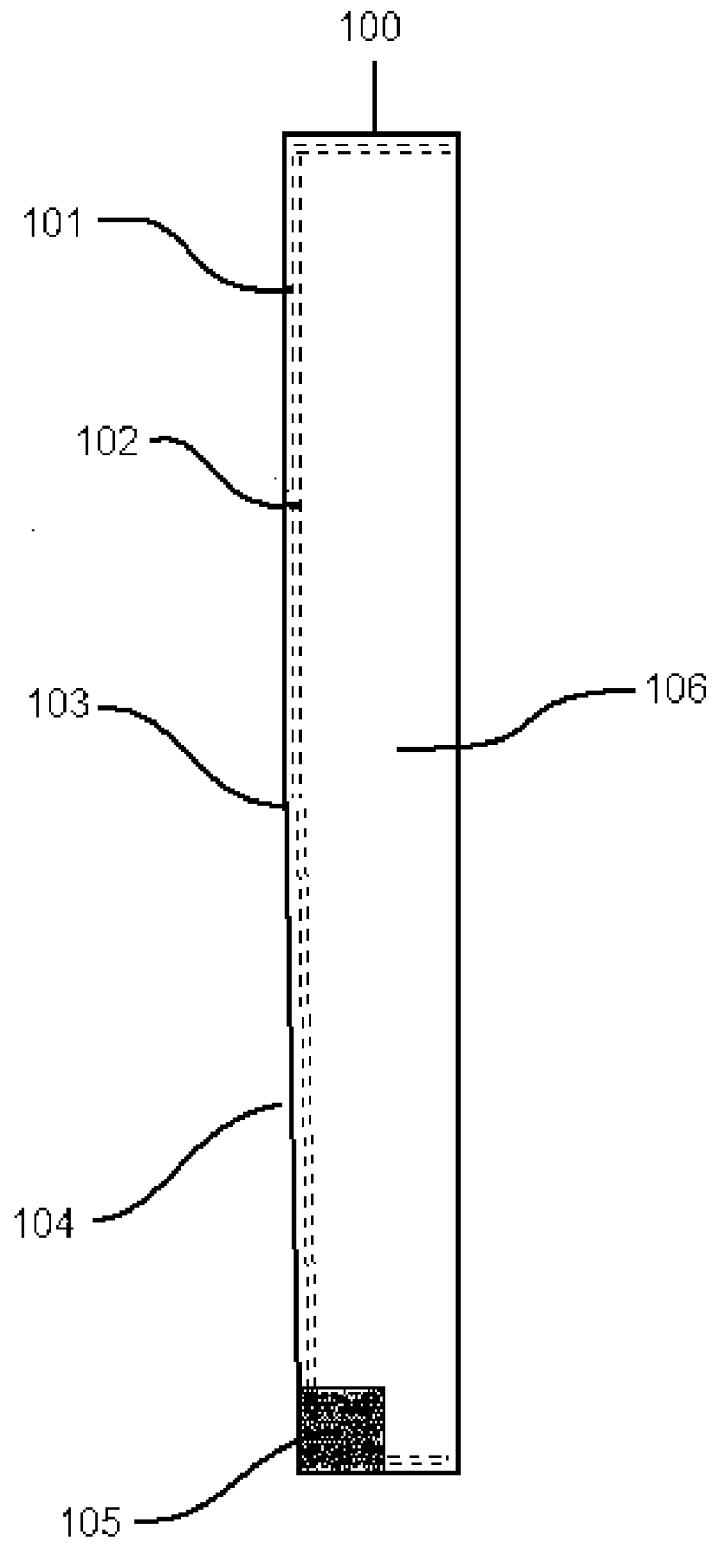

Fig. 1

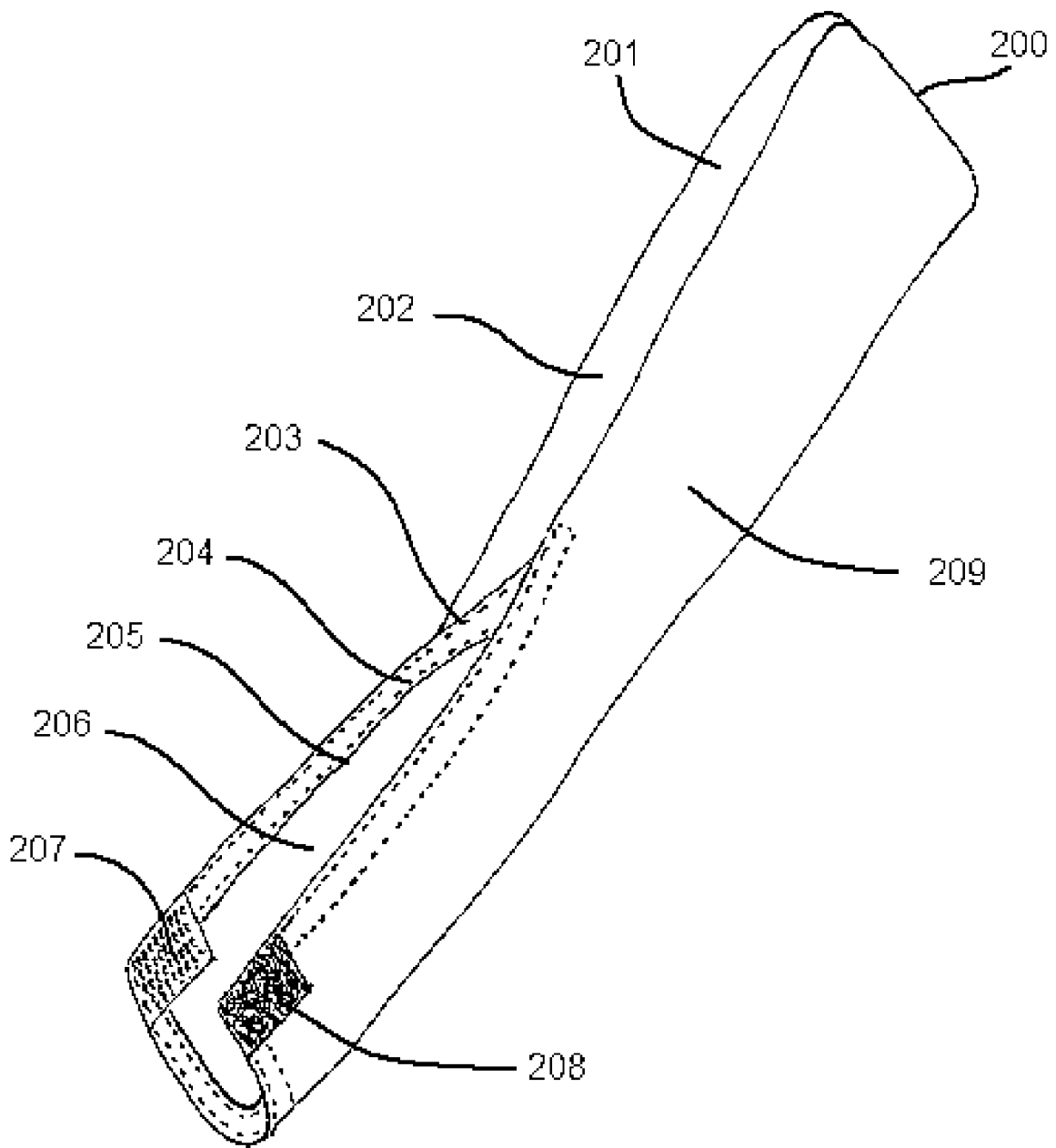

Fig. 2

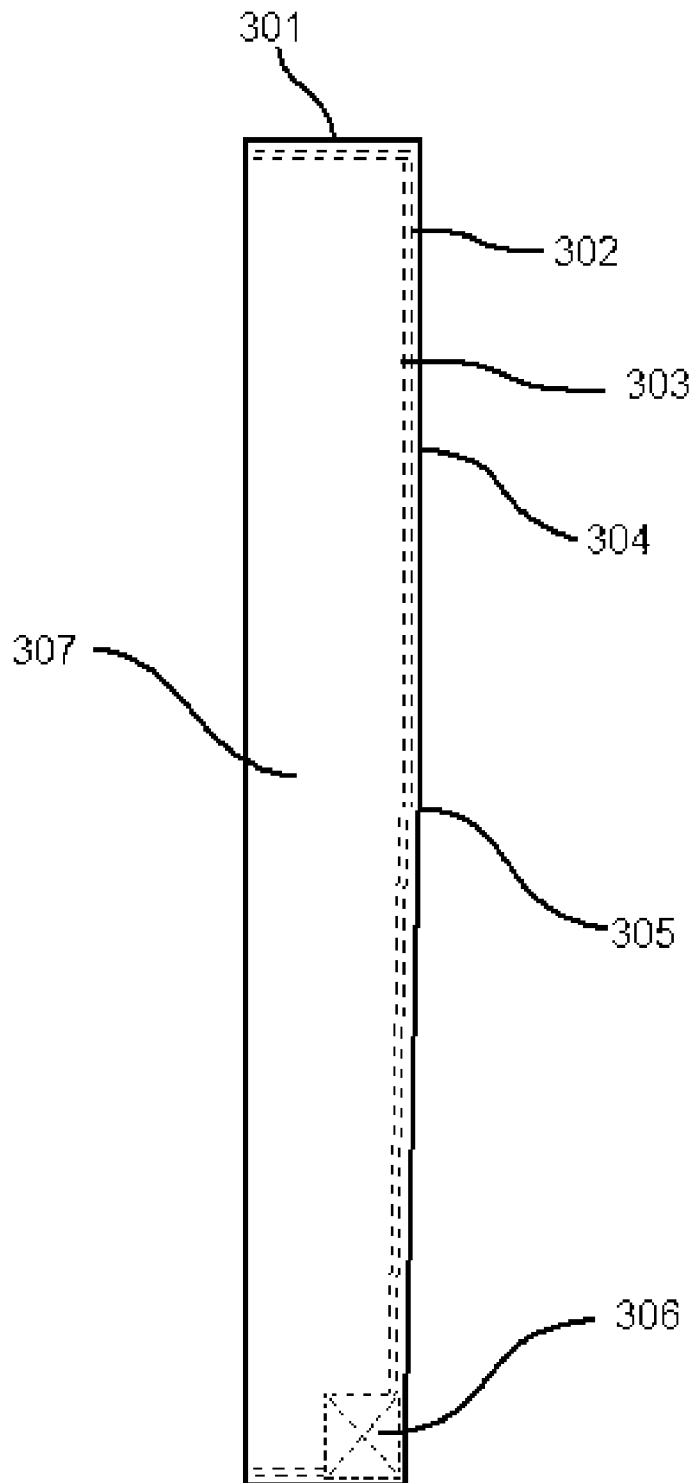

Fig. 3

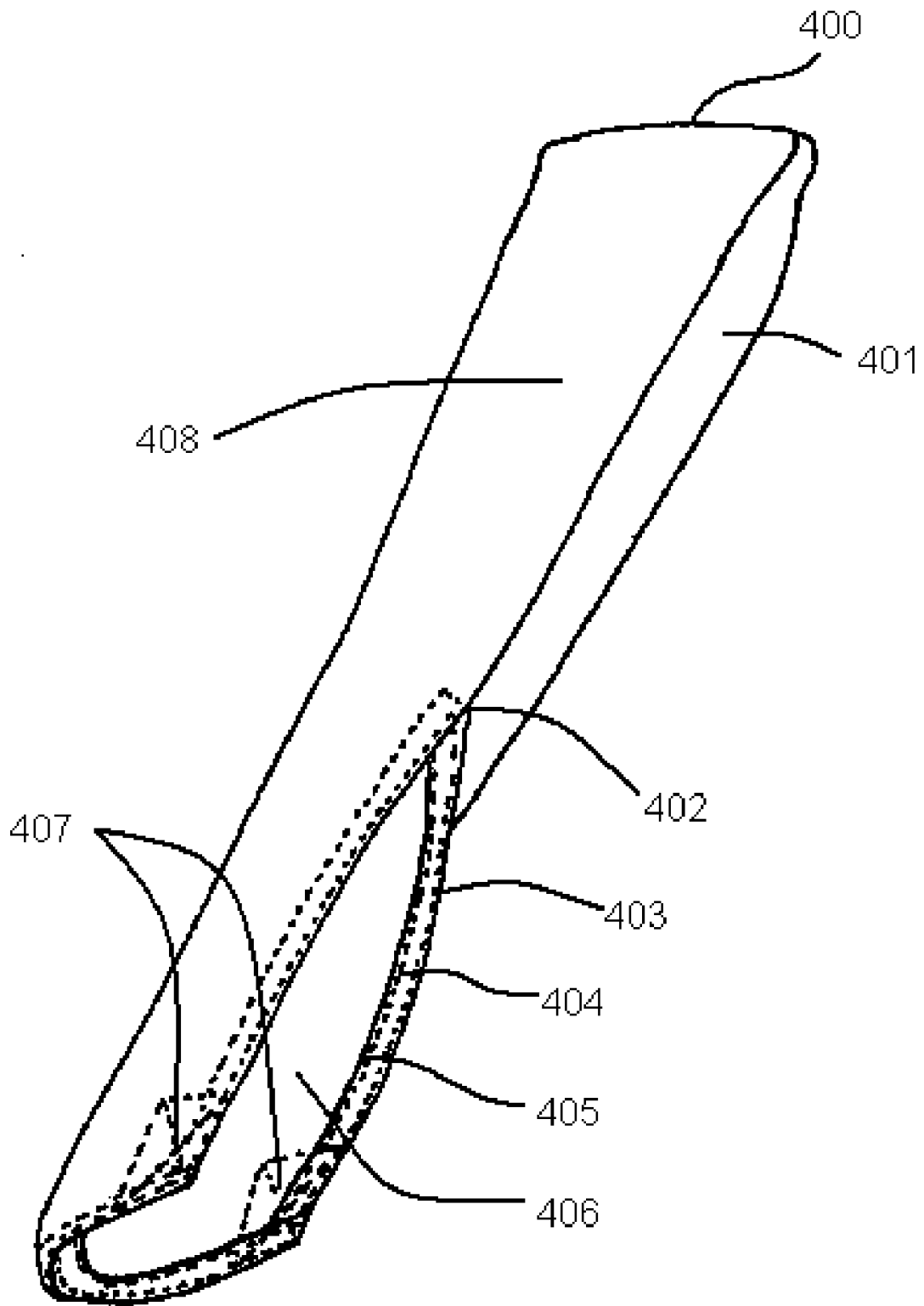

Fig. 4

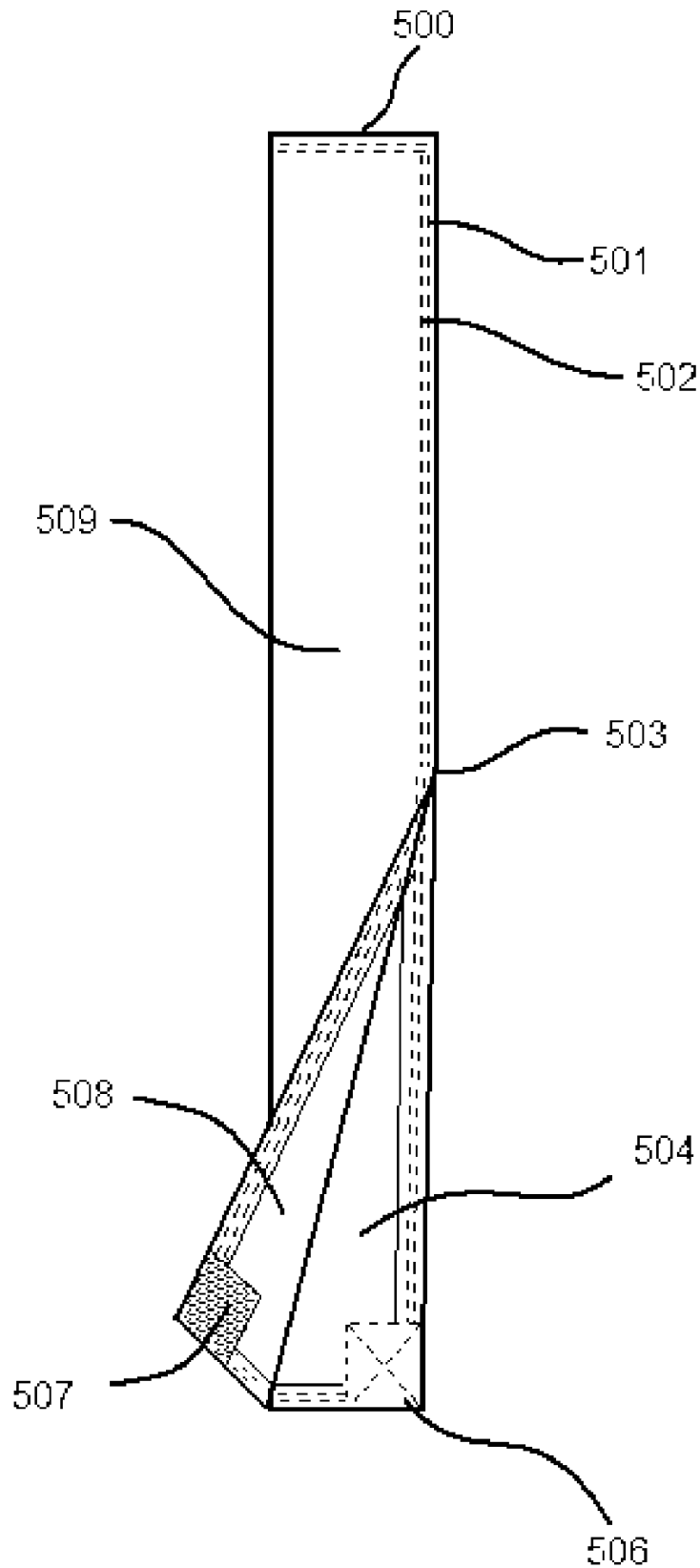

Fig. 5

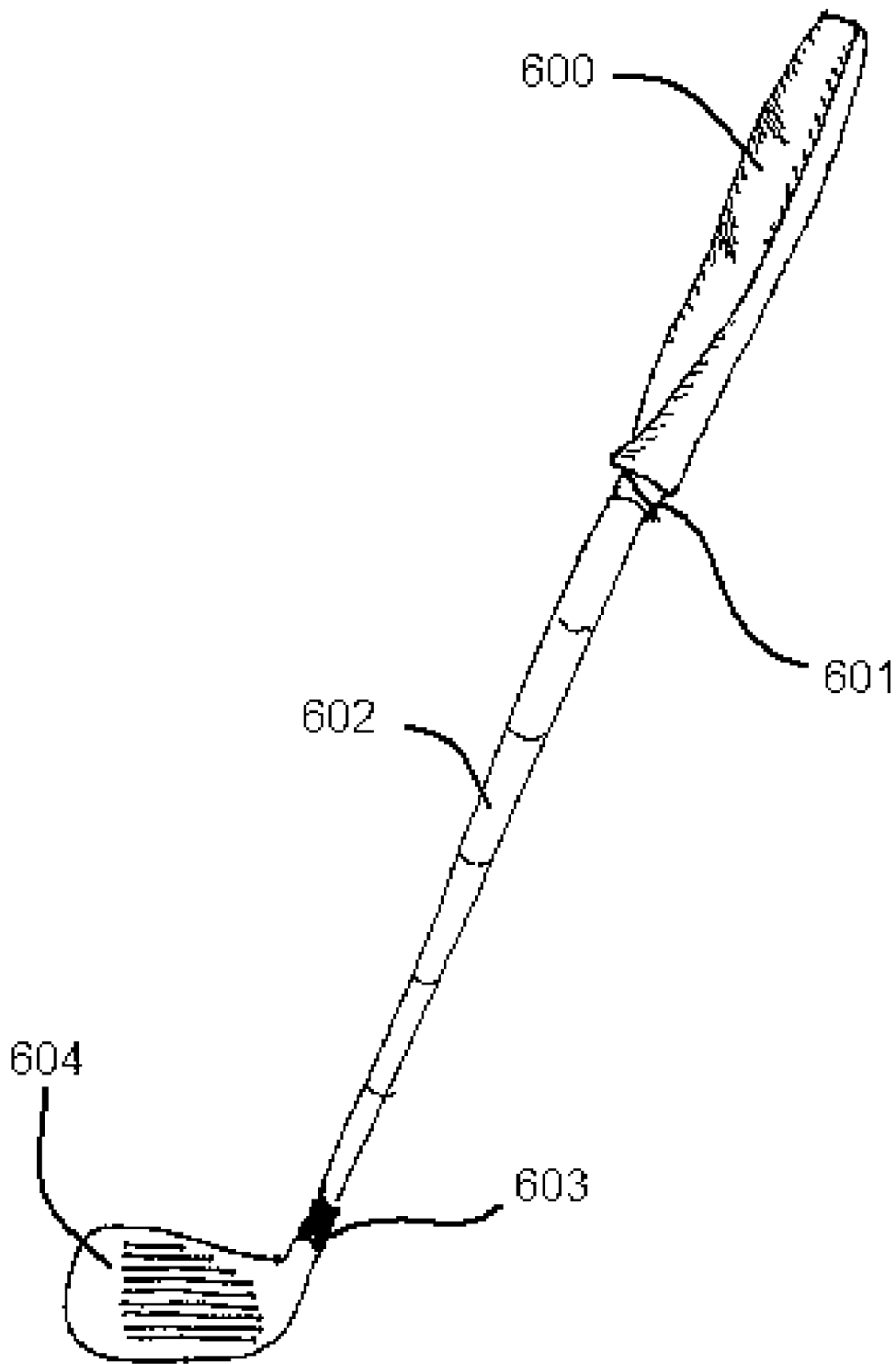

Fig. 6

**[WET WEATHER GOLF CLUB GRIP COVER]****BACKGROUND OF INVENTION**

[0001] Golf is a sport that is played during wet weather conditions. This includes rain and sometimes snow. Golf is also played on courses that are wet from morning dew or watering devices. Therefore, while playing golf during these conditions, the golf clubs and subsequently the golf club grips will become wet. Most golf club grips are made of leather or a rubber material. These materials, when wet, tend to become slippery and difficult to grasp. This problem accounts for misdirected swings at the golf ball and thus an undesired golf ball flight path. In addition, the loss of control of a golf club due to these conditions can be very dangerous. Therefore, the idea of the golf club grip cover is to resolve these issues by increasing the friction between the golfers hands and the golf club grip.

**SUMMARY OF INVENTION**

[0002] The invention encompasses a device, composed of a fabric or material, which will cover the grip or handle of a golf club. The cover is designed to aid in the handling and use of a golf club by increasing the friction between the user and the golf club grip. The cover is cylindrical sock-like unit that is slightly larger than the average golf club grip. The cover also has a slit style opening to aid in the ease of inserting and removing the golf club grip from the cover. The present invention also comprises a hook and loop fastening device located at the opening bottom edges for retaining the cover to the golf club grip/shaft while in use.

**BRIEF DESCRIPTION OF DRAWINGS**

[0003] FIG. 1 is a plan view of the left side of the cover of the present invention;

[0004] FIG. 2 is an orthogonal view of the left side of the cover;

[0005] FIG. 3 is a plan view of the right side of the cover;

[0006] FIG. 4 is an orthogonal view of the right side of the cover;

[0007] FIG. 5 is a plan view of the right side of the cover with the bottom opening folded over depicting the inside of the bottom half of the cover;

[0008] FIG. 6 is a side view of the cover installed upon the grip of an average golf club.

**DETAILED DESCRIPTION**

[0009] FIG. 1 depicts the left side 106 of the current invention. The invention is composed of a fabric, such as linen, which increases friction between the golf club grip and ones hand. The invention comprises a cover, which is manufactured of said fabric through the use of double stitching. This is shown in FIG. 1 as inner 101 and outer 102 stitching. The stitching closes the top 100 and upper side of the cover to create a sock-like tube. Midway 103 along the length of the cover from the top the stitching ceases to attach the two sides of the cover. Therefore, a slit 104 is formed along the bottom half of the cover. The stitching along the bottom of the cover serves to form a cuff. The stitching 105 used for attaching the hook and loop style of fastener can also be seen in this view.

[0010] FIG. 2 is the orthogonal view of the left 209 side depicting the cover with accompanying slit 206 and hook 207 and loop 208 fasteners. The sleeve is formed by stitching the top 200 and the left 202 and right 209 sides together. The remaining material is double stitched 203 and 204 along the inseam to form a collared 205 opening 206. This opening 206 is used for ease of golf club grip insertion. Attached with stitching to the inside of the left side 202 of the cover is a hook 207 type of fastener. This is used in conjunction with a loop 208 fastener attached with stitching to the outside left 209 bottom edge to keep the cover from falling off of the grip.

[0011] The right side 307 of the cover is shown in a plan view in FIG. 3. The top 301 of the fabric is sewn together along with the side 304 using double stitching 302 and 303 for reinforcement. This creates the enclosed portion of the invention. Halfway down the side 304 the enclosure ends 305. From this point to the bottom the enclosure is open for ease of insertion and removal of the golf club grip into and out of the cover. The loop 306 part of the hook and loop fastener is sewn onto the outside bottom right side 307 corner.

[0012] FIG. 4 is the orthogonal view of the right side of the invention. This view depicts the image of the cover in FIG. 3 as if it were turned over. The top 400, left 408 and right 401 sides are shown as sewn together and turned inside-out to create the enclosure. The stitching 403 and 404 is also shown for the cuffs 405, which begin at the slit 402 halfway down the side of the cover. The cuffs 405 are formed by folding the edge of the fabric in on itself and then stitching it together with double stitching 403 and 404. The folded in fabric remains on the inside 406 of the cover when the cover is turned inside out after production. The stitching 407 for the hook 207 and loop 208 type of fastener can also be seen in FIG. 4. The fasteners are stitched around the edges of the fasteners and also diagonally across with an "X" type pattern. One fastener must be attached to the inside bottom corner of the cover, while the other fastener must be attached to the opposite outside corner. This ensures that, when installed as shown in FIG. 6, the cover bottom corners can be fastened to each other for attaching the cover 600 to the grip 601 of a golf club.

[0013] FIG. 5 gives a plan view of the right side 509 of the cover with the inside of the opening folded out. Many of the previously mentioned components are also displayed here. The top edge 500 and right side 509 are sewn with the left side 106 using a double stitching method 501 and 502. The beginning of the slit 503 occurs half-way down the side of the cover. This creates an opening 508 and 504 for the golf club grip to easily slide in and out of. Furthermore, this drawing depicts the hook 507 type of fastener mounted to the inside 508 of the cover. The stitching 506 for the loop part of the fastener is sewn to outside of the opposite corner of the cover. This allows for the left side 106 of the cover to be wrapped around the grip or shaft for a tight fit.

[0014] FIG. 6 is a drawing of the current invention 600 installed upon a golf club grip 601. The drawing depicts an average golf club with head 604, hozzle 603 and shaft 602 for reference.



What is claimed is:

1. A golf club grip cover that is composed of a durable fabric or material suitable for increasing friction between the hand and the grip comprising:

a tubular form that is closed on one end and open at the other end for inserting the golf club shaft and grip.

an open slit which extends from the opening of the cover to half the distance of the entire cover for ease of golf club grip insertion.

2. A golf club grip cover according to claim 1, wherein said cover has a strip of fabric or a "tag" attached to the closed end of the cover for ease of removing the cover from the grip

3. A golf club grip cover according to claim 1, wherein said cover has an additional circular flap of fabric or material attached to the top end, which is used to reinforce the tubular design.

4. A golf club grip cover according to claim 1, wherein said cover is tapered only from the top of the slit opening to the bottom edges of the cover and keeps the same width along the top closed half of the cover.

5. A golf club grip cover according to claim 1, wherein said cover has a hook and loop type of fastening method of attaching the slit opening bottom corners to themselves and thus retaining the cover onto the golf club grip and shaft.

6. A golf club grip cover composed of a stretchable type of form-fitting fabric that will increase friction between the hand and the grip comprising:

a cylindrical sock-like tubular form that is closed on one end and open at the other end for inserting the golf club shaft and grip.

7. A golf club grip cover according to claim 6, wherein said cover uses an elastic band sewn inside the edges of the bottom opening of the cover in order to retain the cover to the golf club handle.

8. A golf club grip cover according to claim 6, wherein said cover has a tapered form that is wider at the upper closed end and narrows as it approaches the open end.

\* \* \* \* \*