

(19)



(11)

**EP 2 474 683 B1**

(12)

**EUROPEAN PATENT SPECIFICATION**

(45) Date of publication and mention of the grant of the patent:  
**30.03.2016 Bulletin 2016/13**

(51) Int Cl.:  
**E04F 11/06** <sup>(2006.01)</sup> **E04F 19/08** <sup>(2006.01)</sup>  
**E04B 9/00** <sup>(2006.01)</sup>

(21) Application number: **12000044.3**

(22) Date of filing: **04.01.2012**

(54) **Fire-rated closure**

Brandschutzklappe

Trappe coupe-feu

(84) Designated Contracting States:  
**AL AT BE BG CH CY CZ DE DK EE ES FI FR GB GR HR HU IE IS IT LI LT LU LV MC MK MT NL NO PL PT RO RS SE SI SK SM TR**

(30) Priority: **11.01.2011 PL 39361611**

(43) Date of publication of application:  
**11.07.2012 Bulletin 2012/28**

(73) Proprietor: **FAKRO PP Spolka z o.o.**  
**33-300 Nowy Sacz (PL)**

(72) Inventor: **Mos, Bartłomiej**  
**33-335 Nawojowa (PL)**

(56) References cited:  
**WO-A1-96/07005 DE-A1- 3 517 836**  
**DE-A1- 19 608 529 DE-C1- 19 717 207**

**EP 2 474 683 B1**

Note: Within nine months of the publication of the mention of the grant of the European patent in the European Patent Bulletin, any person may give notice to the European Patent Office of opposition to that patent, in accordance with the Implementing Regulations. Notice of opposition shall not be deemed to have been filed until the opposition fee has been paid. (Art. 99(1) European Patent Convention).

## Description

**[0001]** This application relates to a fire-rated closure of an opening in a space divider in normal operation being an access through the space divider, and in case of fire being a closure preventing fire propagation and providing protection against high temperature. The closure of the type intended for mounting in the slab, i.e. as an attic access unit, also comprising folding stairs. The closure may also be of the type intended for mounting in the vertical wall, also comprising folding stairs.

**[0002]** Prior art. Fire-rated closures mounted in space dividers, i.e. fire-rated walls and slabs, in form of doors or hatches, usually made of metal are well known. The fire-rated closures are filled with fire-resistant and thermal insulating materials or lined with such materials. The frames are usually made of metal to provide fire resistance, although the metal is a good thermal conductor and does not prevent heat transmission. Also the closures with wooden frames are well known, providing better thermal insulation and lower fire rating.

**[0003]** Known solution from application DE3517836 A1 presents closure for an inspection opening in ceiling having a case and a shutter; in order to improve the fire resistance, closure framing comprises laminated tape, which swells in higher temperature and penetrate through small openings in framing because of what thermal conductivity in this region is reduced.

**[0004]** Solution DE19608529 A1 presents inspection cover which is set into a frame that is installed in a wall. Between frame and cover there are profiles which are intended for securing fire seals, which in higher temperature close channels between cover and frame.

**[0005]** Solution WO96/07005 A1 presents a fire-rated closure for an opening in a space divider, the closure preferably comprising casement and at least one wing which can pivot in the casement, having a frame in which is fitted a fireproof glass pane, wherein the casement and wing comprises a aluminium profiles connected together by connecting member, and separated by fire-protective plates together with expanding members, the closure is preferably fire-protective and after frame melting, provide cohesion among components of frame, which is maintained by expanding members. Connecting members are rigidly connected with one aluminium profile but loosely connected to respective opposite aluminium profile in the form of connection which is loose for shearing stress.

**[0006]** There is also known solution DE19717207 C1 describe extendible ladder which has vertical posts, positioned in the upper area of the trap, which are fixed to a hinge side corner of the trap casing and project at least 800mm from this. The posts support hand rails which are telescopic and can fit into each other. A first hand rail section is pivoted over a first connecting axis to the upper end of the posts. A second hand rail section is pivoted over a second axis at the upper end to the side face supported handrail. Both pivot axes are parallel to the hinge axis.

**[0007]** Disclosure. A fire-rated closure in a space divider comprising a frame, at least partially made of metal, further including a supporting frame, located on one side of the space divider and an opposite frame, located on the other side of the space divider, where both frames are separated with thermal barriers made of fire-resistant material with low thermal conductivity. The thermal barriers may be made of silicate-cement panels. Thermal barriers on four sides of the frame form an insulating frame comprising of the thermal barriers installed with threaded fasteners to the frame.

**[0008]** The supporting frame and the opposite frame are made of bend metal sheet sections, and thermal barriers are fastened to both frames with threaded fasteners seated in thermal barriers. Preferably the supporting frame is made of channel sections with obtuse angle between the web and at least one of the flanges of the channel section. Thermal barriers have inclined surfaces adjacent to the inclined flanges of the channel sections of the supporting frame, and the screws seated in the thermal barriers are fastened through the holes in channel flanges. The inclination allows access to the screws with a suitable tool without the need to cut the second flange of the channel.

**[0009]** The fire-rated closure comprises a hatch movable in relation to the frame, closing the opening in the frame, where the hatch is lined with fire-resistant and thermal insulation materials. The surface of the hatch lateral in relation to its main surface, inside the frame is surrounded with an intumescent seal expanding at high temperature. The closure is mounted in the fire-rated space divider, to provide protection against fire and thermal energy between contiguous rooms. The closure comprises a lock maintaining closed position of the closure, where the tension of a spring holding the hatch in closed position is reduced at high temperature.

**[0010]** The hatch of the fire-rated closure is a box type structure comprising two metal sheets lined with fire-resistant and low thermal conductivity material. One of the metal sheets is shaped as a rebate, which in closed position adhere to a face of the frame in closed position under the spring tension, from the side of hatch movement during opening.

**[0011]** In the first hatch embodiment, both metal sheets are joined with insulating walls made of fire-resistant material with low thermal conductivity transverse to the metal sheets. The walls can be made of silicate-cement panels, identical to the thermal barriers of the frame.

**[0012]** In the second embodiment, the hatch walls transverse to the main surface, joining both metal sheets are made of perforated metal sheets. The perforation reduces the heat transmission area and prevents heat penetration to the other side of the closure.

**[0013]** Elastomeric seals (rubber) are fitted between the hatch and the frame of the fire-rated closure. The elastomeric seals, unlike intumescent seals are used for closing and opening the hatch in normal operation. The seals provide protection in initial stage of the fire, whereas

the function is provided at high temperature by the intumescent seal, which expands and fills the space between the inner frame surface and the hatch walls.

**[0014]** Fire-rated closure is intended for mounting in the building slab, and comprises folding stairs, which open downwards to the room below the slab. For closures mounted in the slab, the supporting frame is located at the top, and the opposite frame is a bottom section, and the hatch is opened downwards, with the stairs. Fire-rated closure comprises a set of springs partially counterbalancing the weight of the stairs and the hatch.

**[0015]** In the first embodiment, the stairs comprise ladder sections, specifically made of metal with hinged joints. Preferably the folding stairs have three sections, where the hinge joining the top section with middle section are mounted on the top surfaces of the stringers, and hinges joining the middle section with bottom section are mounted on the bottom surfaces of the stringers. In closed position, the sections of folded stairs are positioned inside the frame, where the top section is at the bottom, i.e. close to the hatch and the bottom section is at the top.

**[0016]** The stairs are joined with the frame with an axis fixed to the top section of the stairs, mounted in the frame bearings. The hatch of fire-rated closure is supported by the top section of folding stairs, preferably joined with swivel joints providing automatic positioning of the hatch in relation to the frame, and proper adherence.

**[0017]** In the second embodiment, the folding stairs comprise scissor stairs with two parallel multiple pantographs joined with treads. To unfold, the stairs are extended, and the treads are positioned in usable distance, and in closed position the treads are pushed together to fit inside the frame. The hatch is joined with the supporting frame with a hinged mechanism, with two swivel joints on both sides of the hatch, providing a slidable rotation axis of the hatch, with scissor stairs mounted on the hatch.

**[0018]** The two embodiments and joints with fire-rated closure hatch are not comprehensive. The hatch hinged joined with the supporting frame may comprise pull-down stairs instead of scissor stairs. The frame may comprise scissor stairs, which require use of intermediate frame, and the stairs or the intermediate frame may support the hatch.

**[0019]** The spring tension is selected to maintain closed position of the hatch with the stairs. The lock is an additional means of protection, maintaining closed position of the hatch, in case the spring tension is reduced at high temperature.

**[0020]** The presented closures with folding stairs are not the only embodiments of the invention. Fire-rated closure may also be a door in a vertical wall with or without folding stairs, or a closure in the slab without stairs.

**[0021]** Advantages of the invention. Fire-rated closure with thermal barriers, in the frame, between two metal frames is characterized by low thermal conductivity and the metal frame components are non-flammable. The in-

clination of channel flanges facilitates installation of thermal barriers. Additional thermal insulation properties result from the use of insulation walls in the hatch, and the hinge joints facilitate automatic hatch positioning in the frame.

**[0022]** Preferred embodiments of the invention. Fire-rated closure in a space divider of the present invention shown as embodiments in the following drawings, where the following figures shows:

Fig. 1 - Longitudinal section of the fire-rated closure with folding stairs and thermal barriers within the frame.

Fig. 2 - Frame and hatch of Fig. 1 - axonometric view.

Fig. 3 - Cross section of the frame and hatch of Fig. 1, in the plane of screws joining the metal frames with thermal barriers.

Fig. 4 - Cross section of the frame and hatch of Fig. 2, along the lines A-A, with the lock.

Fig. 5 - Cross section of the frame and hatch with insulation thermal barriers within the frame and the hatch.

**[0023]** The fire-rated closure is presented as the embodiments not shown in the figures, described by indication of common features and differences in relation to shown embodiments.

**[0024]** Embodiment 1. Fire-rated closure with a frame 1 and a hatch 2, fixed to the rotatably mounted folding stairs 3. The frame comprising a supporting frame 11, being the top frame and an opposite frame 12, being the bottom frame - separated with longitudinal thermal barriers 13, transverse thermal barriers 14 made of fire-resistant materials with low thermal conductivity, i.e. silicate-cement panels. The supporting frame 11 made of formed metal sheet channel sections, bevelled at 45° at the ends and welded at corners. Supporting frame channels 11 positioned with the webs to the inside of the frame, and inclined bottom flanges forming an obtuse angle between the flange and the web of the channel. The opposite frame 12 made of formed metal sheet sections, channels positioned with the web downwards, welded. Thermal barriers: longitudinal 13 and transverse 14 made of panels cut to the width of frame sides. Longitudinal thermal barriers 13 are longer than the frame clearance by a double panel thickness, and transverse thermal barriers 14 adhere with its face to the end sections of longitudinal thermal barriers outside the frame clearance 13. The thermal barriers are joined with screws 15, at the end sections of longitudinal thermal barriers 13, the screws are seated in the face of the transverse thermal barriers 14 - forming a complete insulation frame. Thermal barriers: longitudinal 13 and transverse 14, fastened to the supporting frame 11 with top screws 16, fastened to the opposite frame 12 with bottom screws 17, where all screws are seated in the thermal barrier 13, 14. The top surface of thermal barriers 13, 14 are inclined in relation to the inclination of the bottom flange of the sup-

porting frame channel 11, and the top screws are inclined likewise 16 providing access for suitable tools without additional cut-outs in the supporting frame.

**[0025]** The hatch 2 is a box type structure comprising two metal sheets, bottom sheet 21 and top sheet 22 both made of metal sheets. The bottom sheet 21 edges are tucked in by 180°, forming a rebate 23 seated in the recess 18 of the frame, formed by the joint of the channel and the z-bar in the opposite frame 12. The top sheet 22 edges are folded 24 perpendicularly downwards and upwards to the inside. The top section of the side wall folded at 180° 25 is seated in the fold of the top sheet. The bottom section of the side wall 25 is folded perpendicularly to the outside and seated in the fold of the bottom sheet 21 forming a rebate 23. The side walls 25 of the hatch are made of perforated sheet to reduce the area of heat conduction. The box structure of the hatch 2 comprises the fire-resistant panels 26, a thermal insulation as an outer layer and thermal insulation 27 as an inner layer.

**[0026]** Folding stairs 3 comprise pull-down stairs made of three hinged joined sections: top 31, middle 32 and bottom 33. The section names are determined by the location in open position, whereas sections in closed position inside the frame are located in reverse positions, i.e. the top section 31 is at the bottom, with middle 32 and top section 33 above the top section. Folding stairs 3 are joined with a frame 1 with the axis 34, mounted in the bearings 19 of the supporting frame 11. Below the top section 31 of the folding stairs 3 are the swivel joints 35 supporting the hatch 2 of the fire-rated closure. Folding stairs 3 comprise the springs 36 counterbalancing the weight of the stairs and the hatch 2, which lift the hatch and the stairs during closing and absorb the descent during opening. Folding stairs further include the telescopic handrail 37 joining the top section 31 with the middle section 32, with a spring inside assisting lifting of the middle 32 and bottom 33 section during folding.

**[0027]** The hatch 2 comprises the intumescent seal 4 along the side walls 25 of the hatch. The seal expands at high temperature and fills the space between the frame and the hatch and prevents flame, hot air and smoke from entering adjacent rooms. Intumescent seal 4 is a disposable type, since its original dimensions are not restored after cooling and must be replaced. Apart from the intumescent seal 4, the fire-rated closure comprises two elastomeric seals for normal operation, fitted between the frame 1 and the hatch 2, on the whole perimeter, fixed to the frame. The elastomeric seals comprise the bottom seal 41, fitted in the recess 18 of the frame 1, and the top seal 42, in the fold 24 of the top sheet 22 of the hatch, where external surface of the fold cooperates with the top seal.

**[0028]** The lock 5 comprises the bolt 51 with the spring (not shown, inside the body) with inclined end of its top surface, to provide latching of the bolt 51 in the recess of the thermal barrier 14 of the frame 1, when the hatch 2 is lifted. To move the hatch 2, the bolt 51 is retracted by

the lug 52, which is also a handle for the hatch. The lock comprises the bolt support 53 fastened with screws 54 to the opposite frame 12 of the frame 1, although in closed position, the support is not used, since the spring 36 lifts the hatch 2 upwards, and between the bolt 51 and the support 53 there is a clearance. The bolt 51 rests on the support 53 in case of a fire, if the spring 36 tension is reduced at high temperature. The hatch 2 features through cut-outs in the fire-resistant panel 26 and the thermal insulation panel 27, both located from the bottom of the hatch to position the lock 5. Above the lock 5, the cut-out in the thermal insulation panel 27 is lined with an thermal barrier 55

**[0029]** Embodiment 2. Fire-rated closure comprising a frame 1 with a supporting frame 11, being the top frame in this embodiment and an opposite frame 12, being the bottom frame, identical to the first embodiment. Also thermal barriers: longitudinal 13 and transverse 14 and forming the insulating frame, as well as top screws 16 joints with inclined channel flange 11 of the supporting frame and bottom screws 17 with the opposite frame 12 are identical to the first embodiment.

**[0030]** A hatch 6 comprising two sheets joined with longitudinal 61 and transverse 62 thermal barriers joined at corners, identical to the thermal barriers of the frame. A top sheet 63 of the hatch has a single, perpendicular bend 64 directed downwards. A bottom sheet 21, identical to the first embodiment has a 180° fold, forming a rebate 23 corresponding to the recess 18 in the frame. The bottom sheet 21 is joined with the thermal barriers: longitudinal 61 and transverse 62 with z-bar 65, where a single wall is positioned in the fold forming the rebate 23, and the second parallel wall is positioned in the recess in the outer surfaces of the thermal barriers 61, 62. The top sheet 63 is joined with the thermal barriers 61, 62 with screws 66, seated in the thermal barriers.

**[0031]** The box type structure of the hatch 6 lined with two fire-resistant panels 26, thermal insulation panels 27 and the intumescent seal 4 is identical to the first embodiment. Also the elastomeric seals are identical: bottom seal 41 and top seal 42, where the top seal 42 cooperates with the outer surface of the fold 64. The hatch 6 is supported by the section of stairs identical to the first embodiment with swivel joints; the stairs mounted in the bearings of the frame, springs and lock are also identical.

**[0032]** Embodiment 3. Fire-rated closure with a frame including a supporting frame and an opposite frame separated with thermal barriers, identical to the first embodiment. The closure does not comprise stairs, and the hatch is opened upwards, and cooperates with the supporting frame of the frame, without the springs. The hatch has the sheets and thermal barriers identical to the first embodiment, and is mounted in the frame.

**[0033]** Embodiment 4. Fire-rated closure with doors installed in a vertical wall at the height of approx. 1 meter over the floor. The closure comprises a supporting frame and an opposite frame separated with thermal barriers, identical to the first embodiment. A single section of fold-

ing stairs opened downwards in the direction of hatch opening is rotatably mounted in the supporting frame in the bottom section of the frame. In its closed position, the section is positioned vertically in the frame. The sheets and thermal barriers are identical to the first embodiment, and the hatch is mounted in the frame.

### Claims

1. A fire-rated closure for an opening in a space divider, the closure preferably comprising folding stairs, intended for mounting in said space divider, the space divider being preferably fire-rated, to provide protection against fire and thermal energy from transferring to adjacent rooms, said fire-rated closure comprising a frame, at least partially of metal, mounted in said space divider, with a movable hatch, said hatch being lined with fire-resistant and thermal insulating materials, the surface transverse to the main hatch surface, inside the frame being fitted with an intumescent seal expanding at high temperature, and the closure further including a lock, said lock maintaining said hatch in closed position of case of a fire wherein the frame (1) comprises a supporting frame (11) on one side of said space divider and an opposite frame (12) on the opposite side of said space divider, separated by a thermal barrier (13, 14), said thermal barriers (13, 14) being made of fire-resistant material with low thermal conductivity and said thermal barriers (13, 14) are joined with said supporting frame and said opposite frame with fasteners, preferably threaded (16, 17) and said fasteners seated in the thermal barriers.
2. The fire-rated closure of claim 1 wherein the hatch (2) is a box type structure made of sheets with perforated transverse walls (25) and the inside lined with fire-resistant panel (26) and low thermal conductivity panel (27).
3. The fire-rated closure of claim 1 wherein the hatch (6) is a box type structure made of two sheets (21, 63), specifically metal sheets, joined with the insulating walls (61, 62) made of fire-resistant panel (27) and low thermal conductivity panel (27).
4. The fire-rated closure of claim 1, 2 or 3 wherein the elastomeric seals (41, 42) are fitted between said hatch (2, 6) and said frame.
5. The fire-rated closure of claim 1, 2, 3 or 4 for mounting in the slab with folding stairs wherein the supporting frame (11) of said frame (1) is positioned on the top, and the opposite frame (12) is positioned at the bottom, and said hatch (2) is opened downwards with said stairs (3), and comprises springs (36) partially counterbalancing the weight of said stairs and

said hatch.

6. The fire-rated closure of claim 5 wherein said stairs are pull-down type, made of hinged ladder sections (31, 32, and 33) positioned inside said frame (1) in folded position.
7. The fire-rated closure of claim 5 wherein said stairs are scissor type, made of two parallel multiple pantographs with treads positioned inside said frame in folded position.
8. The fire-rated closure of claim 6 or 7 wherein said stairs (3) are joined with said frame (1) with the axis (1) mounted in the bearings of the supporting frame, and said hatch (2) mounted on the top section (31) of said folding stairs (3), preferably joined with swivel joints (35).
9. The fire-rated closure of claim 6 or 7 wherein said hatch is joined with said supporting frame with the hinged mechanism, and said folding stairs are mounted on said hatch.
10. The fire-rated closure of claim 5, 6, 7, 8 or 9 wherein the spring tension counterbalancing (36) the weight of said stairs and said hatch maintains closed position of said hatch (2) with said stairs (3), and the lock (5) is an additional means of protection in case the tension of said spring is reduced at high temperature.
11. The fire-rated closure of claim 1, 2, 3, 4, 5, 6, 7, 8, 9 or 10 wherein the supporting frame (11) of said frame (1) is made of formed metal sheet sections.
12. The fire-rated closure of claim 11 wherein the supporting frame (11) of said frame is made of channel sections, where at least between one flange of said channel and the web thereof is an obtuse angle, and said thermal barriers (16, 17) are inclined at the surface adhering to the channel flanges, with screws (16) seated in said thermal barriers.

### Patentansprüche

1. Feuerschutzabschluss einer Öffnung in der Bautrennwand, insbesondere einer Öffnung mit klappbarer Treppe, bestimmt zur Installation in einer Bautrennwand, insbesondere in einer Feuerschutzwand, der davor schützen soll, dass das Feuer und die mit ihm verbundene Wärmeenergie von einem Raum des Gebäudes in einen anderen, durch diesen Abschluss getrennten Raum gelangt, der eine Zarge besitzt, die insbesondere mindestens teilweise aus Metall gefertigt und in der Bautrennwand montiert ist, und einen in Bezug auf die Zarge beweglichen Flügel zum Abschließen der Durchgangsöffnung in

- der Zarge hat, wobei dieser Flügel mit feuerbeständigem und thermisch isolierendem Stoff ausgefüllt ist, und auf seinen Querflächen in Bezug auf die Hauptfläche des Flügels, die in das Innere der Zarge eingehen, ist von einer sich unter erhöhtem Temperatureinfluss ausdehnenden Dichtung umgeben, der Abschluss ist dagegen mit einem Riegelmechanismus ausgerüstet, der mindestens im Falle eines Brandes den Flügel geschlossen hält, **dadurch gekennzeichnet, dass** die Zarge (1) aus einem Tragrahmen (11), die an der einen Seite der Bautrennwand angeordnet ist und aus dem gegenüberliegenden Rahmen (12), der an der anderen Seite dieser Trennwand angeordnet ist, besteht, die durch die Isoliereinlagen (13, 14) aus feuerbeständigem Stoff mit einer niedrigen Wärmeleitfähigkeit getrennt sind und die Isoliereinlagen (13, 14) sind mit dem Tragrahmen und dem gegenüberliegenden Rahmen durch Verbindungselemente verbunden, vorzugsweise durch Gewindeverbindungselemente, eingesetzt in Isoliereinlagen.
2. Der Feuerschutzabschluss nach Anspruch 1, **dadurch gekennzeichnet, dass** der Flügel (2) eine Kastenkonstruktion hat, gefertigt insbesondere aus Blech, deren Querwände (25) in Bezug auf die Hauptfläche des Flügels perforiert sind und das Innere der Kastenkonstruktion mit feuerbeständigem Stoff (26) ausgefüllt ist, das eine niedrige Wärmeleitfähigkeit (27) aufweist.
3. Der Feuerschutzabschluss nach Anspruch 1, **dadurch gekennzeichnet, dass** der Flügel (6) eine Kastenkonstruktion hat, die aus zwei Deckplatten (21, 63) besteht, insbesondere aus Blech, die durch Isolierwände (61, 62) aus feuerbeständigem Stoff mit niedriger Wärmeleitfähigkeit verbunden sind, und das Innere der Kastenkonstruktion mit feuerbeständigem Stoff (27) ausgefüllt ist, das eine niedrige Wärmeleitfähigkeit (27) aufweist.
4. Der Feuerschutzabschluss nach Anspruch 1, **dadurch gekennzeichnet, dass** er zwischen dem Flügel (2, 6) und der Zarge die Elastomer-Mehrfachdichtungen (41, 42) hat.
5. Der Feuerschutzabschluss nach Anspruch 1, oder 2, oder 3, oder 4, bestimmt zur Montage in der Decke und verbunden mit der klappbaren Treppe, **dadurch gekennzeichnet, dass** der Tragrahmen (11) der Zarge (1) oben angebracht wird, und der gegenüberliegende Rahmen (12) ist ein unterer Rahmen, der Flügel (2) wird dagegen nach unten zusammen mit der Treppe (3) geöffnet, und darüber hinaus hat der Abschluss ein System von Federn (36), die mindestens teilweise das Gewicht der Treppe und des Flügels ausgleichen.
6. Der Feuerschutzabschluss nach Anspruch 5, **dadurch gekennzeichnet, dass** die Treppe aus den scharniermäßig verbundenen Leitersegmenten (31, 32, 33) zusammengeklappt wird, die im zusammengeklappten Zustand der Treppe innerhalb der Zarge (1) untergebracht wird.
7. Der Feuerschutzabschluss nach Anspruch 5, **dadurch gekennzeichnet, dass** die klappbare Treppe von einem sog. Messertyp ist, die zwei parallele, mehrfache Pantographen, verbunden mit den Stufen, besitzt und die im zusammengelegten Zustand der Treppe innerhalb des Rahmens untergebracht werden.
8. Der Feuerschutzabschluss nach Anspruch 6, oder 7, **dadurch gekennzeichnet, dass** die Treppe (3) mittels einer Achse (1), die im Rahmen der Zarge gelagert ist, mit der Zarge (1) verbunden ist, und der Flügel (2) am oberen Segment (31) der klappbaren Treppe (3) aufgehängt ist, verbunden vorzugsweise durch Gelenkverbindungselemente (35) mit diesem Segment.
9. Der Feuerschutzabschluss nach Anspruch 6, oder 7, **dadurch gekennzeichnet, dass** der Flügel mittels eines Scharniermechanismus mit dem Tragrahmen der Zarge verbunden ist, und die klappbare Treppe auf diesem Flügel abgesetzt wird.
10. Der Feuerschutzabschluss nach Anspruch 5, oder 6, oder 7, oder 8, oder 9, **dadurch gekennzeichnet, dass** die Zugkraft der Federn, in ihrem Ausgleichssystem (36) das Gewicht der Treppe und des Flügels, so gewählt ist, dass sie den Flügel (2) zusammen mit der Treppe (3) in der geschlossenen Stellung hält, und das Riegelsystem (5) ist eine zusätzliche Sicherung, die bei einer Verringerung der Zugkraft der Federn unter dem Einfluss einer hohen Temperatur tätig ist.
11. Der Feuerschutzabschluss nach Anspruch 1, oder 2, oder 3, oder 4, oder 5, oder 6, oder 7, oder 8, oder 9, oder 10, **dadurch gekennzeichnet, dass** der Tragrahmen (11) der Zarge (1) aus den aus Blech gebogenen Profilen gefertigt ist.
12. Der Feuerschutzabschluss nach Anspruch 11, **dadurch gekennzeichnet, dass** der Tragrahmen (11) der Zarge aus U-Profilen gefertigt ist, wobei zwischen mindestens einer Ebene des U-Profils und seiner Stegebene ein stumpfer Winkel ist, und die Isoliereinlagen (16, 17) haben eine Neigung auf ihren Oberflächen, die an die geneigten Ebenen der U-Profile des Tragrahmens anliegen, durch welche die Schrauben (16) gehen, die in den Isoliereinlagen eingesetzt werden.

## Revendications

1. Fermeture ignifuge d'ouverture dans une cloison de construction, notamment d'une ouverture avec escalier escamotable, destinée à installer dans une cloison de construction notamment ignifuge, ayant pour but la protection contre la pénétration de l'incendie et de l'énergie thermique qui lui est associée, depuis un local de bâtiment à un second local séparé par cette fermeture, ayant un dormant, notamment au moins partiellement métallique, monté dans la cloison de construction, et possédant un ouvrant mobile par rapport au dormant, qui fermant le trou de passage dans le dormant, cet ouvrant ayant un remplissage en matériaux réfractaires et isolants thermiquement, et sur ses surfaces transversales par rapport à la surface principale de l'ouvrant, entrant à l'intérieur du dormant, est entourée d'un joint gonflant sous l'impact d'une température surélevée, la fermeture étant équipée d'un mécanisme de verrouillage, qui au moins durant l'incendie maintient l'ouvrant en position fermée, **caractérisée en ce que** le dormant (1) est composé d'un bâti (11), situé sur un côté de la cloison de construction, et d'un cadre opposé (12), situé de l'autre côté de cette cloison, les deux séparés par des semelles isolantes (13, 14) en matériau réfractaire à basse conductivité thermique les semelles isolantes (13, 14) étant assemblées avec le bâti et le cadre opposé par des raccords, avantageusement filetés, encastrés dans les semelles isolantes.
 

5
2. Fermeture ignifuge selon la revendication 1, **caractérisée en ce que** l'ouvrant (2) a une construction caissonnée, notamment exécutée en tôle, dont les parois transversales (25) par rapport à la surface principale de l'ouvrant sont perforées, et à l'intérieur de la construction caissonnée se trouve un remplissage réfractaires (26) et à basse conductivité thermique (27).
 

20
3. Fermeture ignifuge selon la revendication 1, **caractérisée en ce que** l'ouvrant (6) a une construction caissonnée, composée de deux panneaux de toiture (21, 63) notamment en tôle, unis par des parois isolantes (61, 62) en matériau réfractaire à basse conductivité thermique, et à l'intérieur de la construction caissonnée de l'ouvrant se trouve un remplissage réfractaires (27) à basse conductivité thermique (27).
 

25
4. Fermeture ignifuge selon la revendication 1, ou 2, ou 3, **caractérisée en ce que** entre l'ouvrant (2, 6) et le dormant, elle a des joints élastomères (41, 42) à usage multiple.
 

30
5. Fermeture ignifuge selon la revendication 1, ou 2, ou 3, ou 4, destinée pour le montage dans le plancher et assemblée avec l'escalier escamotable, **caracté-**

35
- risée en ce que le bâti (11) du dormant (1) est situé en haut, et le cadre opposé (12) est un cadre inférieur, et l'ouvrant (2) s'ouvre avec l'escalier (3) vers le bas, et en outre, la fermeture a un jeu de ressorts (36) d'équilibrage au moins partiel, du poids de l'escalier et de l'ouvrant.
 

40
6. Fermeture ignifuge selon la revendication 5, **caractérisée en ce que** l'escalier est composé de segments d'échelle (31, 32, 33) situés en position pliée de l'escalier à l'intérieur du dormant (1).
 

45
7. Fermeture ignifuge selon la revendication 5, **caractérisée en ce que** l'escalier escamotable est de type ciseau, ayant deux pantographes parallèles unis par des marches, qui en position pliée de l'escalier sont situées à l'intérieur du dormant.
 

50
8. Fermeture ignifuge selon la revendication 6, ou 7, **caractérisée en ce que** l'escalier (3) est assemblé avec le dormant (1) à l'aide d'un axe (1) inséré dans les paliers dans ce dormant, et l'ouvrant (2) est suspendu au segment supérieur (31) de l'escalier escamotable (3), assemblé avantageusement avec ce segment à l'aide de raccords articulés (35).
 

55
9. Fermeture ignifuge selon la revendication 6, ou 7, **caractérisée en ce que** l'ouvrant est assemblé avec le bâti du dormant à l'aide d'un mécanisme à charnière, et l'escalier escamotable est encastré sur cet ouvrant.
 

60
10. Fermeture ignifuge selon la revendication 5, ou 6, ou 7, ou 8, ou 9, **caractérisée en ce que** la force de tension des ressorts dans leur jeu d'équilibrage (36) du poids de l'escalier et de l'ouvrant est telle, qu'elle maintient l'ouvrant (2) avec l'escalier (3) en position fermée, et l'ensemble de verrouillage (5) est une protection auxiliaire, agissante en cas de diminution de la force de tension des ressorts sous l'impact de haute température.
 

65
11. Fermeture ignifuge selon la revendication 1, ou 2, ou 3, ou 4, ou 5, ou 6, ou 7, ou 8, ou 9, ou 10, **caractérisée en ce que** le bâti (11) du dormant (1) est exécuté de profilés pliés de tôle.
 

70
12. Fermeture ignifuge selon la revendication 11, **caractérisée en ce que** le bâti (11) du dormant est exécuté de profilés en U, dans lesquels entre au moins une aile du profilé et son âme est créé un angle obtus, et les semelles isolantes (16, 17) ont une inclinaison sur leurs surfaces contiguës aux ailes inclinées des profilés en U du bâti, par lesquelles passent les vis (16) encastrés dans les semelles isolantes.
 

75

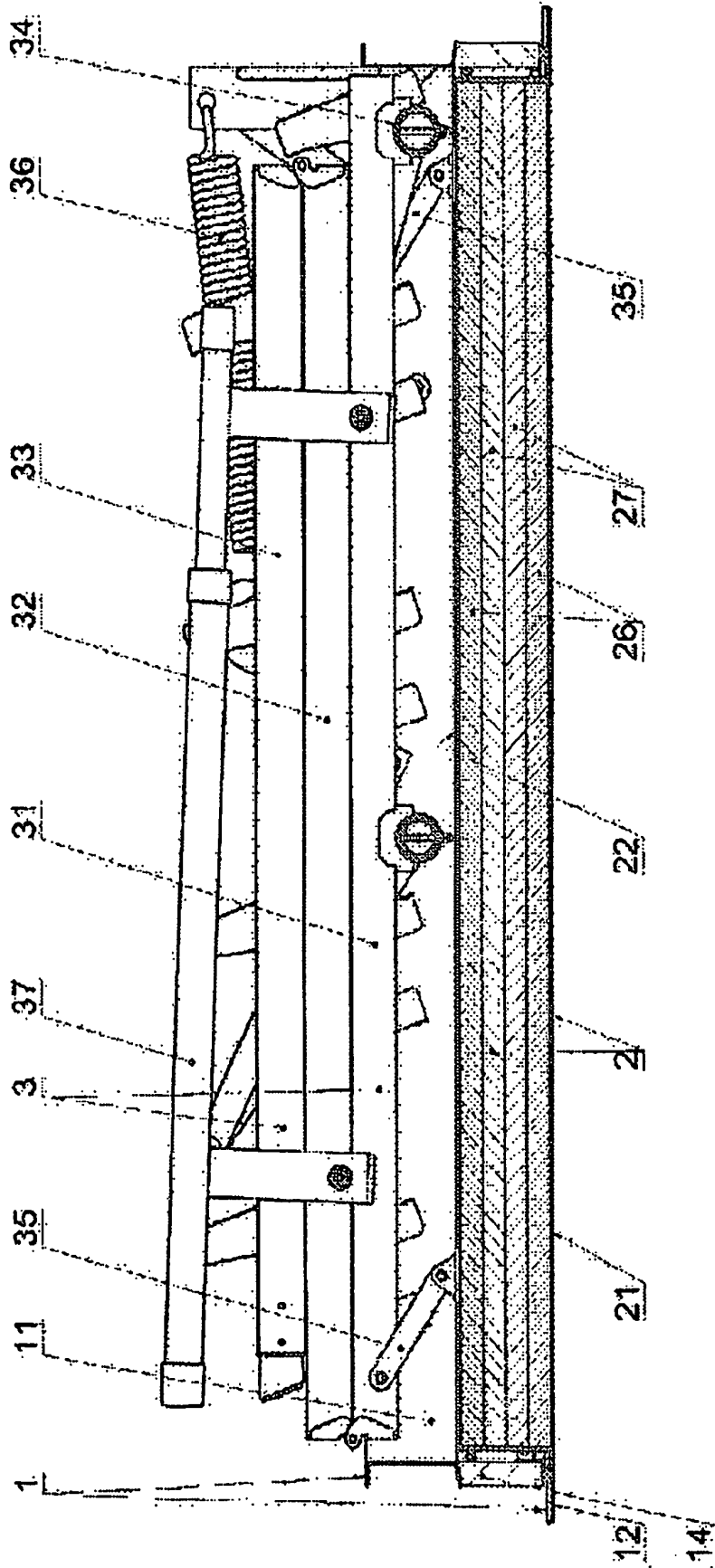

Fig. 1



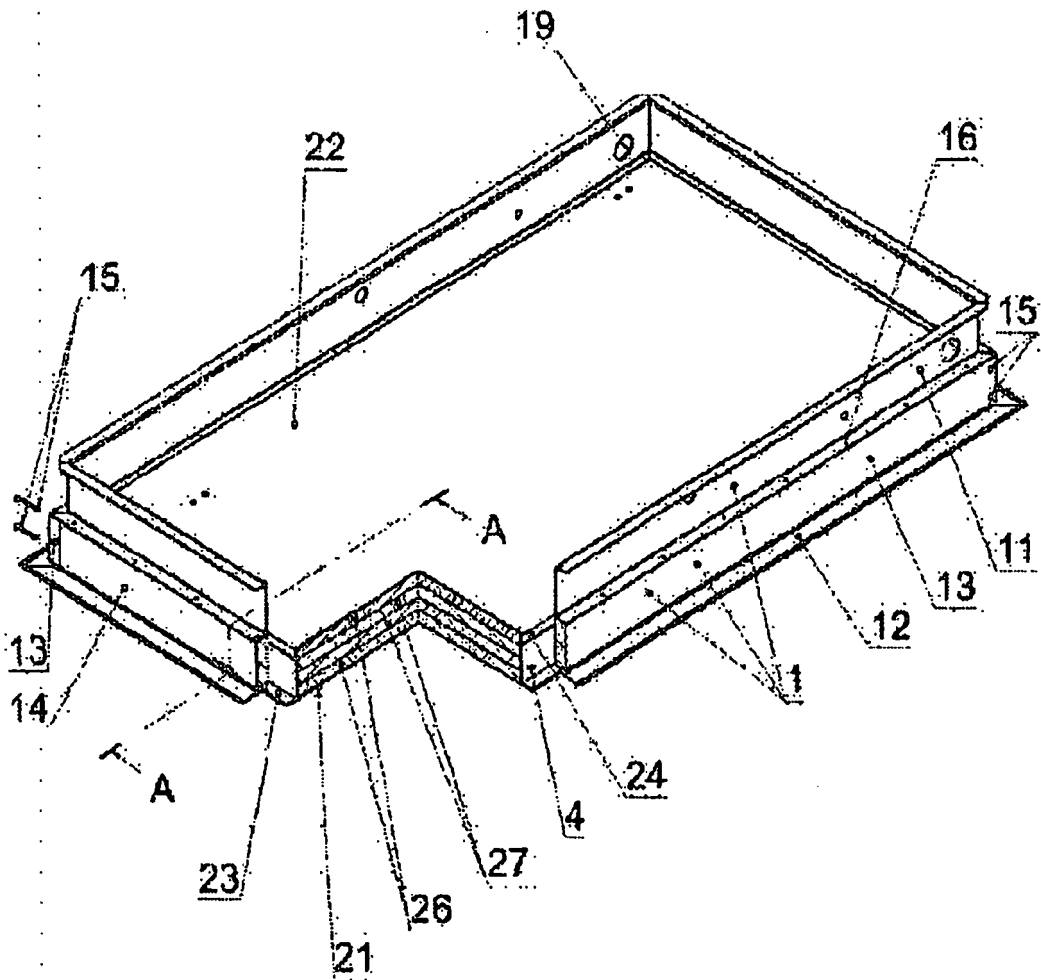

Fig. 2

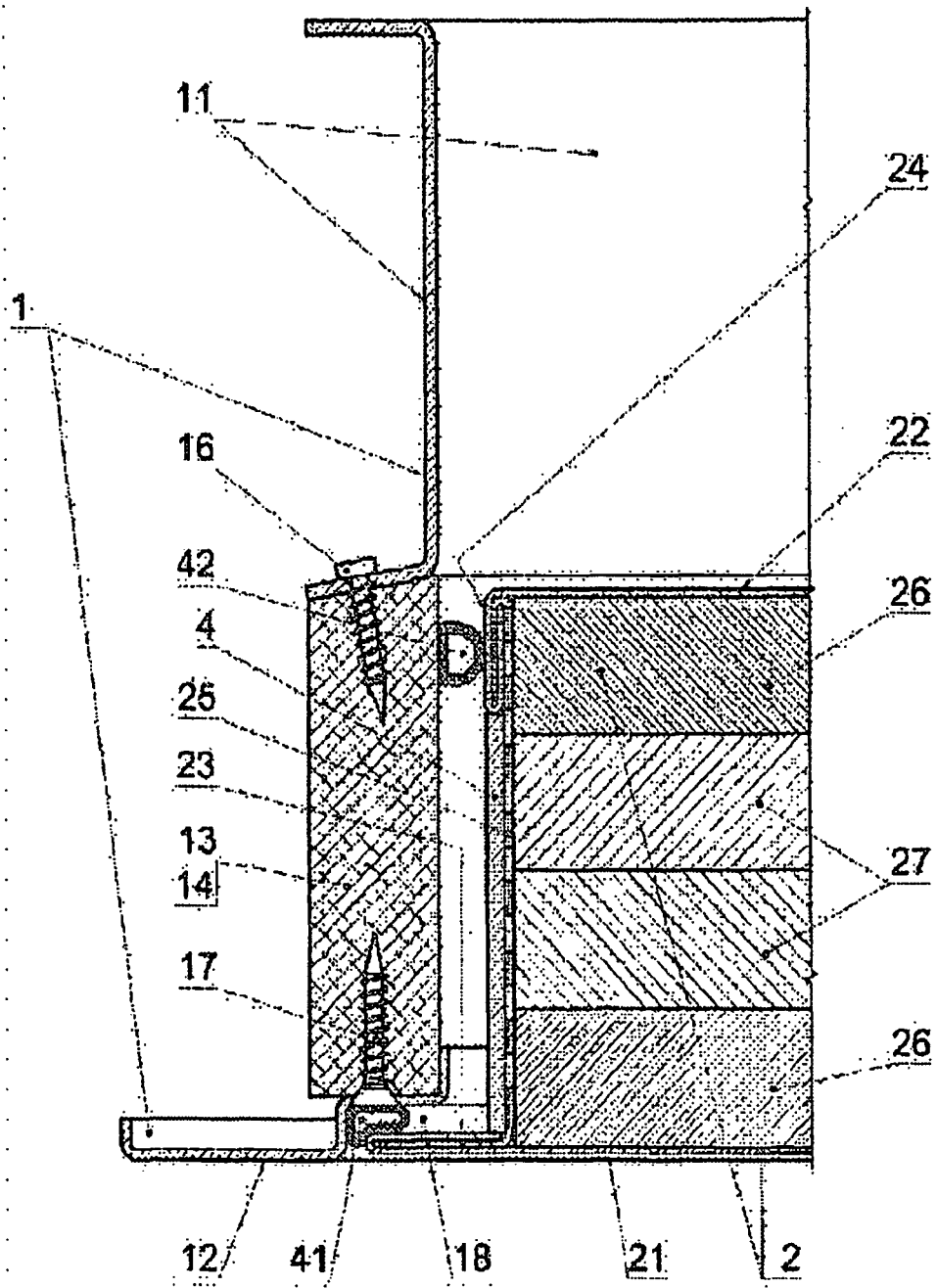

Fig. 3

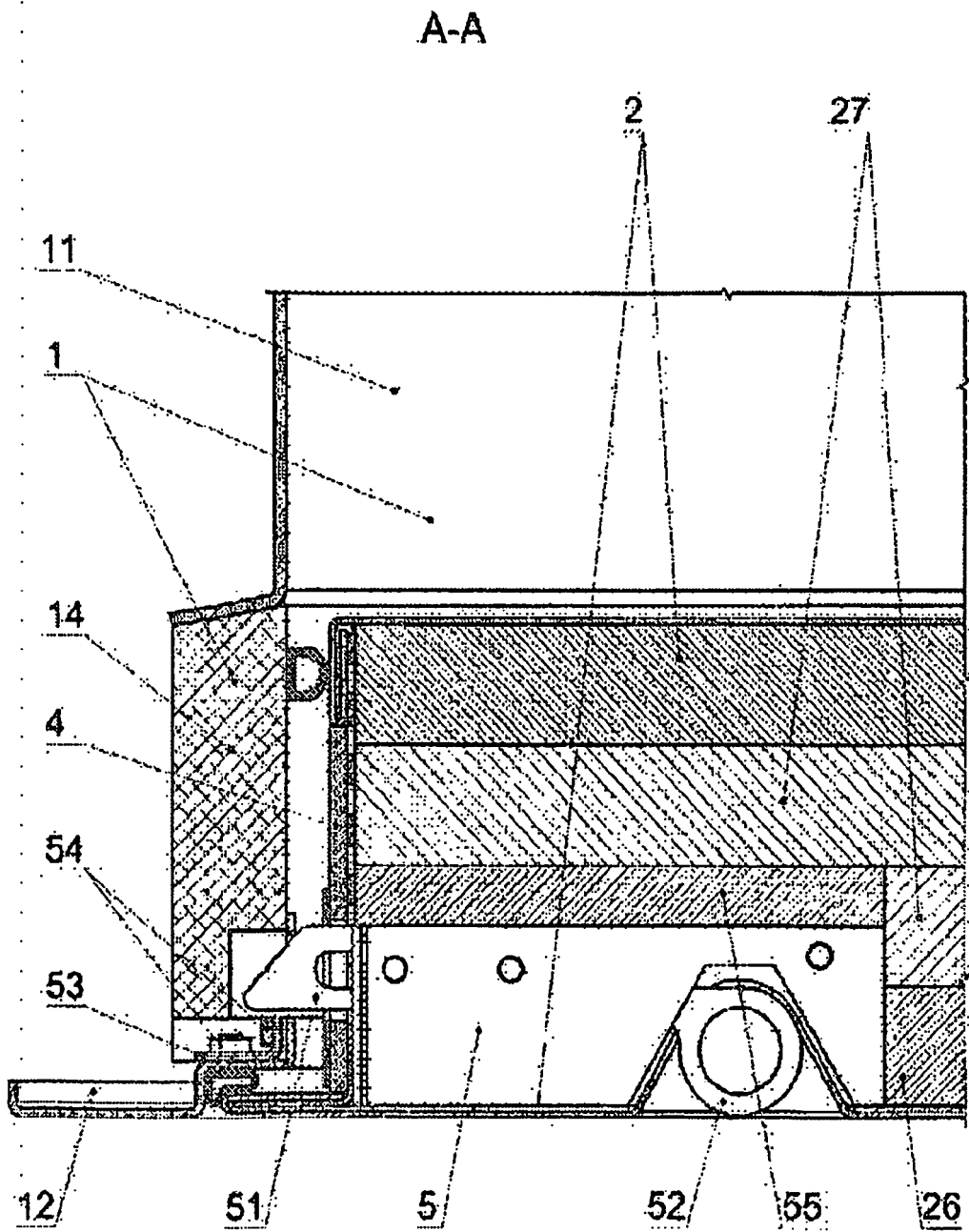

Fig. 4

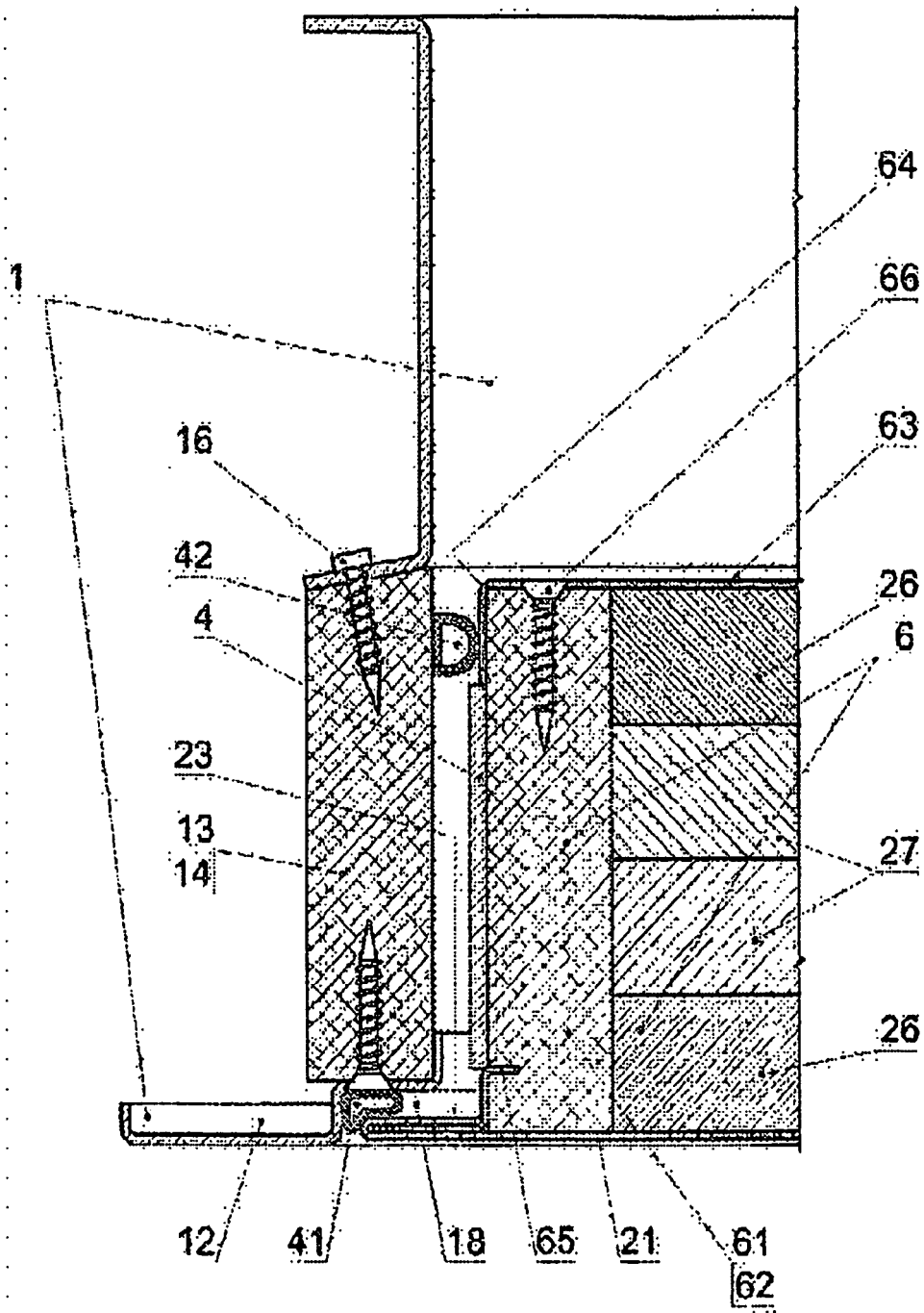

Fig. 5

**REFERENCES CITED IN THE DESCRIPTION**

*This list of references cited by the applicant is for the reader's convenience only. It does not form part of the European patent document. Even though great care has been taken in compiling the references, errors or omissions cannot be excluded and the EPO disclaims all liability in this regard.*

**Patent documents cited in the description**

- DE 3517836 A1 [0003]
- DE 19608529 A1 [0004]
- WO 9607005 A1 [0005]
- DE 19717207 C1 [0006]