



(12) **United States Design Patent**
Cropley et al.

(10) **Patent No.:** **US D861,576 S**
(45) **Date of Patent:** **** Oct. 1, 2019**

(54) **ROOF RACK EXTRUSION SUITABLE FOR DIRECT MOUNT OF ROOF TOP TENTS**

(71) Applicant: **Rhino Rack Australia Pty Limited,**
Rydalmere (AU)

(72) Inventors: **Richard Oswald Cropley,** Rydalmere (AU); **Christopher John Murty,** Rydalmere (AU); **Matthew James Pummell,** Rydalmere (AU)

(73) Assignee: **Rhino Rack Australia Pty. Ltd.,** Rydalmere (AU)

(**) Term: **15 Years**

(21) Appl. No.: **29/645,328**

(22) Filed: **Apr. 25, 2018**

(30) **Foreign Application Priority Data**

Oct. 30, 2017 (AU) 201716561

(51) **LOC (12) Cl.** **12-16**

(52) **U.S. Cl.**
USPC **D12/412**

(58) **Field of Classification Search**

USPC D12/414.1, 401-414, 89-93, 16, 96-100, D12/433-434, 548, 552, 559, 561; D6/552, 513, 567; D25/38.1, 43, 125, D25/119, 121, 122, 124; 135/88.01, 95; 150/165-167, 158; 280/770; 160/32, 26; 296/136.01, 190.08, 190.01-190.02, 77.1, 296/100.01-100.06, 98; D3/304-306
CPC B60R 9/00; B60R 9/02; B60R 9/04; B60R 9/08; B60R 9/055; B60R 9/058; B60R 9/06; B60R 9/065; B60R 9/10; B60R 9/12

See application file for complete search history.

(56) **References Cited**

U.S. PATENT DOCUMENTS

D312,235 S * 11/1990 Dixon D12/408
D332,243 S * 1/1993 Collins D12/413

(Continued)

FOREIGN PATENT DOCUMENTS

KR 20160133604 * 11/2016 B29C 45/00

OTHER PUBLICATIONS

Rhino-Rack Euro Square Bar Roof Rack System, AutoAccessoriesGarage.com, [online], [site visited Mar. 8, 2019]. <URL: <https://www.autoaccessoriesgarage.com/Cargo-Carriers-Roof-Racks/Rhino-Rack-Euro-Square-Bar-Roof-Rack-System>> (Year: 2019).*

(Continued)

Primary Examiner — T Chase Nelson

Assistant Examiner — Jonathan J. Han

(74) *Attorney, Agent, or Firm* — Cooper & Dunham LLP

(57) **CLAIM**

The ornamental design for a roof rack extrusion suitable for direct mount of roof top tents, as shown and described.

DESCRIPTION

FIG. 1 is a top perspective view of a roof rack extrusion suitable for direct mount of roof top tents, in accordance with the present design;

FIG. 2 is an enlarged partial bottom perspective view thereof;

FIG. 3 is bottom view thereof;

FIG. 4 is an enlarged view of the area 4 encircled by broken lines in FIG. 3 thereof;

FIG. 5 is a side view thereof;

FIG. 6 is a front view thereof; and,

FIG. 7 is a top view thereof.

The broken lines in FIGS. 3 and 4 are included to identify area of enlargement and form no part of the claimed design.

The shading represents contour of the claimed design.

1 Claim, 7 Drawing Sheets

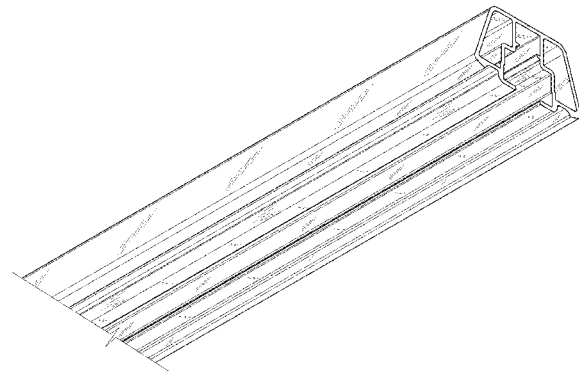
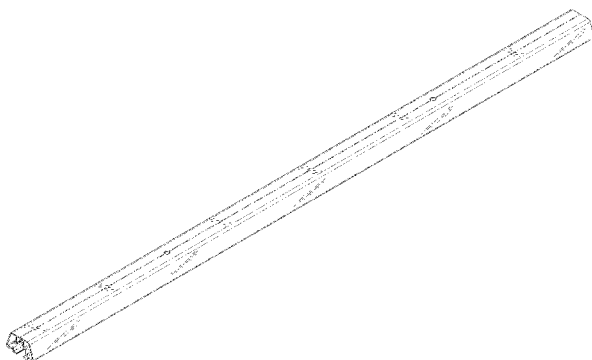

(56)

References Cited

U.S. PATENT DOCUMENTS

6,425,508 B1 * 7/2002 Cole B60R 9/045
 224/320
 6,561,398 B1 * 5/2003 Cole B60R 9/048
 224/324
 D488,055 S * 4/2004 Ter Braak D8/377
 D492,637 S * 7/2004 Thompson, Sr. D12/223
 D561,680 S * 2/2008 Foley D12/408
 D562,217 S * 2/2008 Davis D12/408
 D562,218 S * 2/2008 Foley D12/408
 D566,034 S * 4/2008 Davis D12/408
 D616,035 S * 5/2010 Kosir D20/44
 7,726,528 B2 * 6/2010 Foley B60R 9/048
 224/324
 7,726,529 B2 * 6/2010 Foley B60R 9/048
 211/20
 D622,208 S * 8/2010 Sautter D12/408
 D623,117 S * 9/2010 Farber D12/408
 D633,031 S * 2/2011 Robertson D12/412
 8,136,709 B2 * 3/2012 Jeli B60R 9/12
 224/316
 8,534,518 B2 * 9/2013 Shen B60R 9/058
 224/322
 D691,550 S * 10/2013 Moeller D12/412
 D701,163 S * 3/2014 Kuschmeader D12/408

D726,072 S * 4/2015 Scott D12/49
 D746,761 S * 1/2016 Cagampang D12/414
 D768,556 S * 10/2016 McFadden D12/414
 D769,790 S * 10/2016 McFadden D12/414
 D777,814 S * 1/2017 Verhoeven D15/145
 9,718,410 B2 * 8/2017 Cropley B60R 9/058
 D805,214 S * 12/2017 Bizzarri D25/38.1
 D816,373 S * 5/2018 Schwandt D6/580
 D831,562 S * 10/2018 Salsi D12/412
 2018/0236946 A1 * 8/2018 Shen B60R 9/058

OTHER PUBLICATIONS

Rhino-Rack Heavy Duty RLT600 Ditch Mount 2-Bar Roof Rack—
 Black, AmericanTrucks.com, [online], [site visited Mar. 8, 2019].
 <URL: <https://www.americantrucks.com/rhinorack-heavy-duty-rlt600-ditch-mount-2bar-roof-rack-black-0408-supercab.html>> (Year: 2019).*

Rhino RTS02 Mazda Tribute Tracks (pr), RoofRack.com.au, [online],
 [site visited Mar. 8, 2019]. <URL: <https://roofrack.com.au/product/rhino-rts02-mazda-tribute-tracks-pd/>> (Year: 2019).*

Rhino RB1800S Heavy Duty Bar (Silver 1800mm) (ea), RoofRack.com.au, [online], [site visited Mar. 8, 2019]. <URL: <https://roofrack.com.au/product/rhino-rb1800s-heavy-duty-bar-silver-1800mm-ea/>> (Year: 2019).*

* cited by examiner

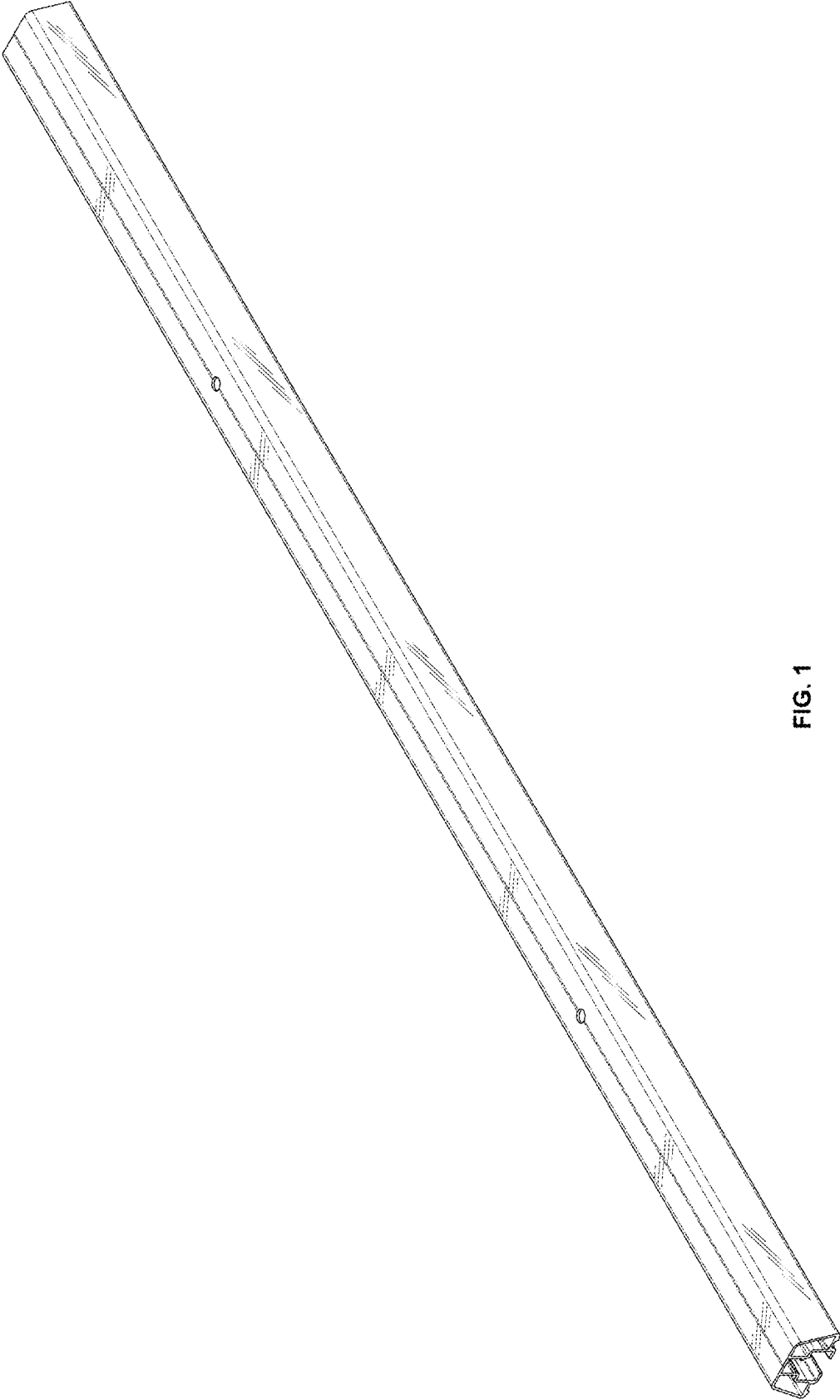

FIG. 1

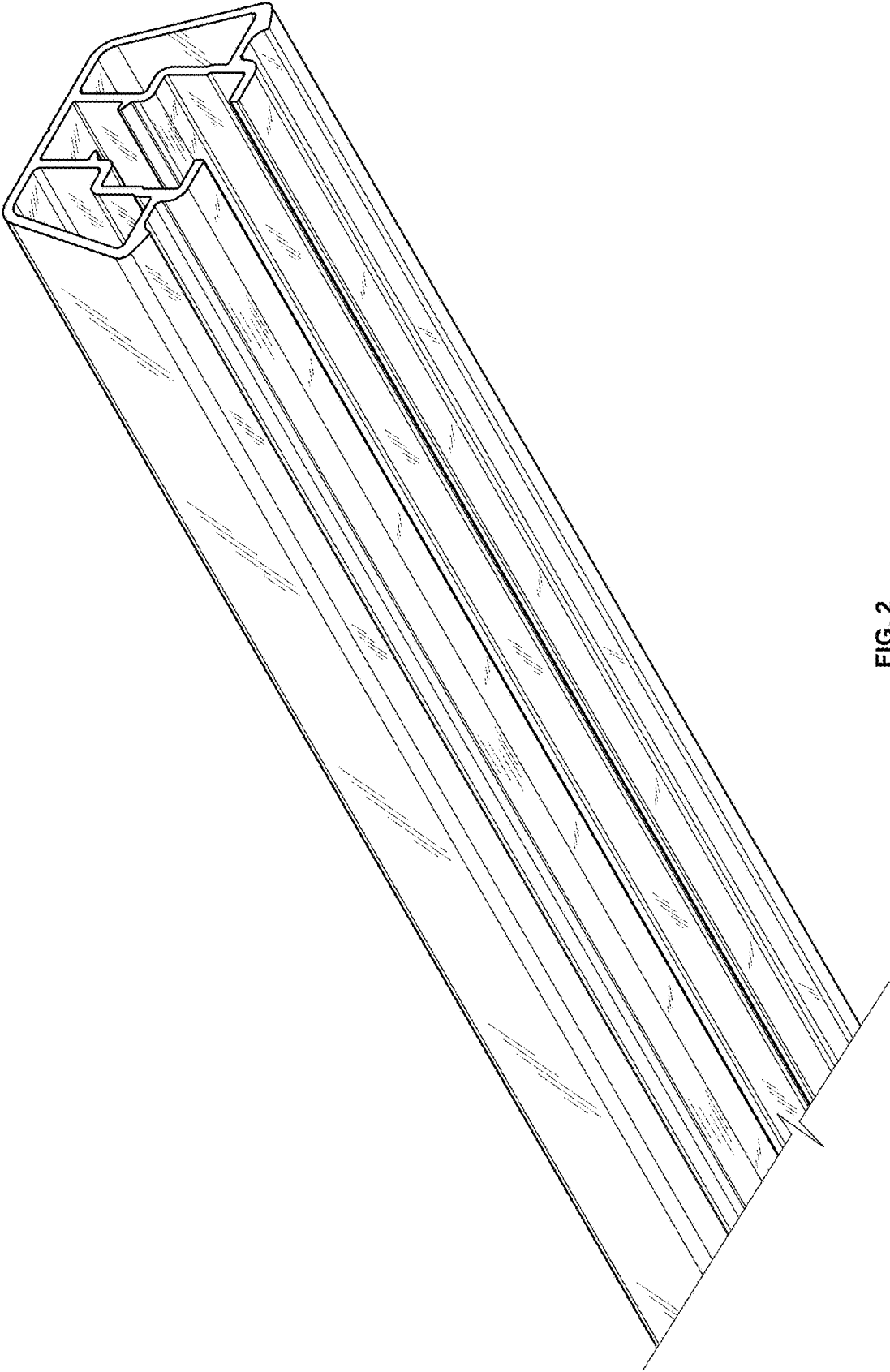

FIG. 2

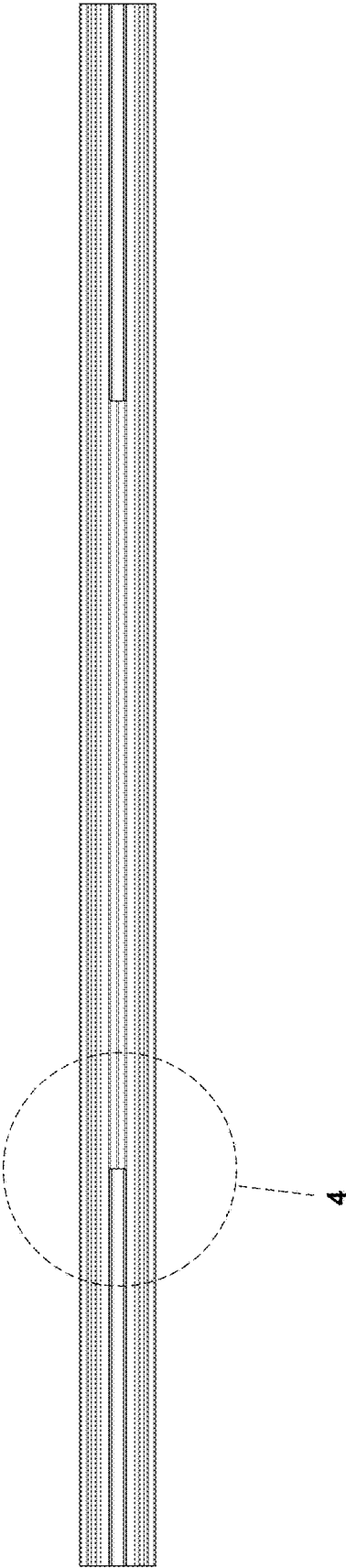

FIG. 3

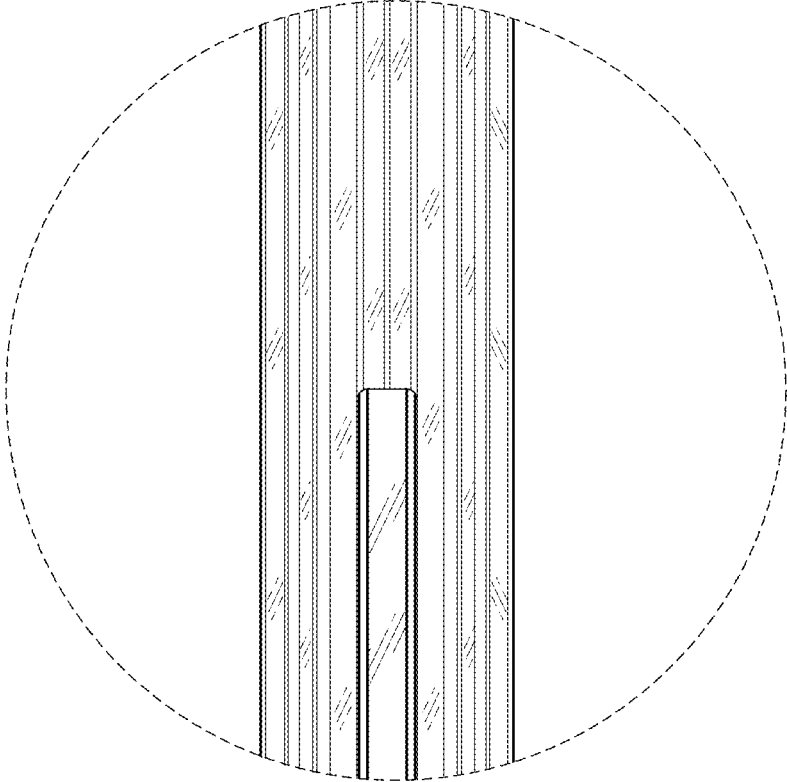

FIG. 4

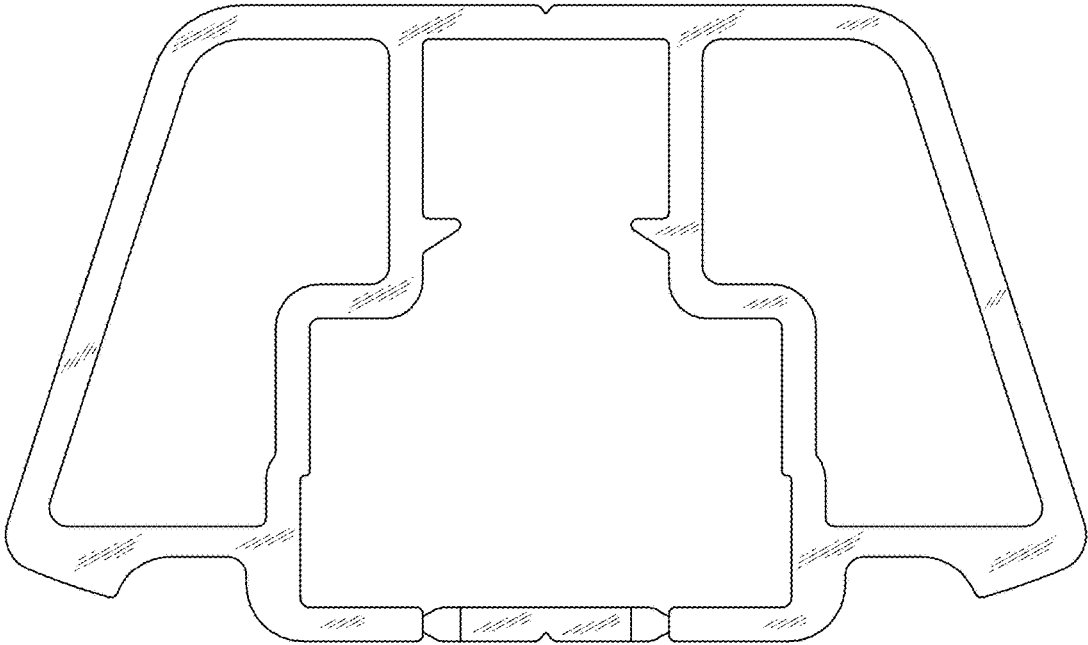

FIG. 5



FIG. 6

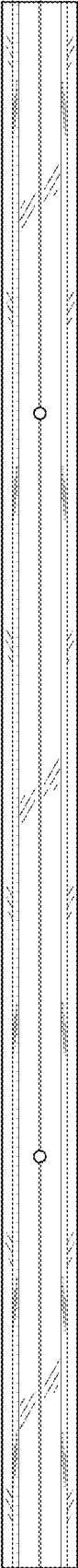

FIG. 7