



(19) **United States**

(12) **Patent Application Publication**
Buddharaju et al.

(10) **Pub. No.: US 2012/0291827 A1**

(43) **Pub. Date: Nov. 22, 2012**

(54) **SPRAY TINES FOR A DISHWASHER RACK**

Publication Classification

(75) **Inventors:** **Satish Kumar Raju Buddharaju**,
Louisville, KY (US); **Joel Charles Boyer**,
Louisville, KY (US); **Errin Gnadinger**,
Louisville, KY (US); **Jonathan Charles Crosby**,
Louisville, KY (US); **Eric B. Devins**,
Louisville, KY (US)

(51) **Int. Cl.**
A47L 15/42 (2006.01)

(52) **U.S. Cl.** 134/198

(73) **Assignee:** **GENERAL ELECTRIC COMPANY**,
Schenectady, NY (US)

(57) **ABSTRACT**

Tines that can provide a spray into the interior of containers placed onto a rack of a dishwasher are provided. More particularly, hollow tines or tines having an internal fluid path for feeding washing fluid to one or more openings at or near an upper end of the tines are described. As a fluid is sprayed or ejected from the opening(s), it provides for the cleaning of the interior of glasses, containers, and other dishes placed over the tines.

(21) **Appl. No.:** 13/110,993

(22) **Filed:** May 19, 2011

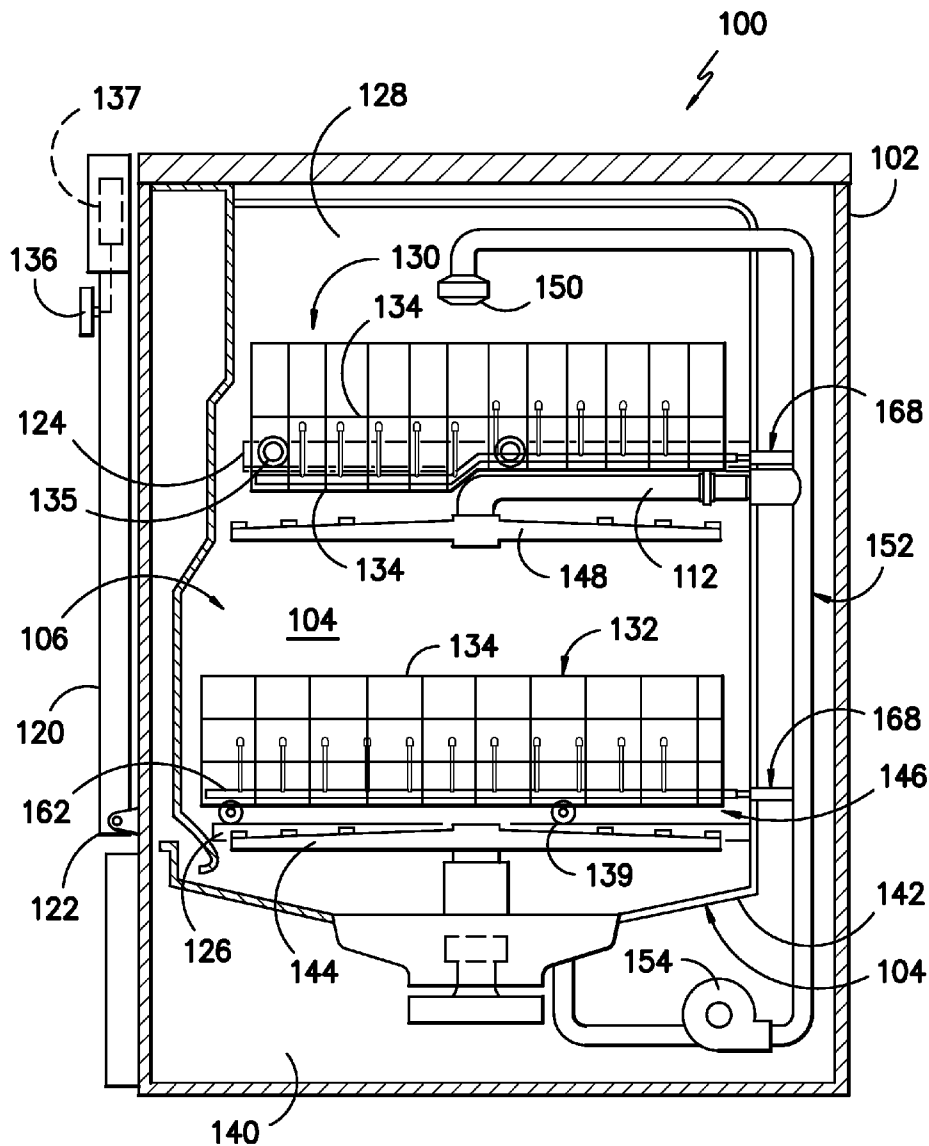

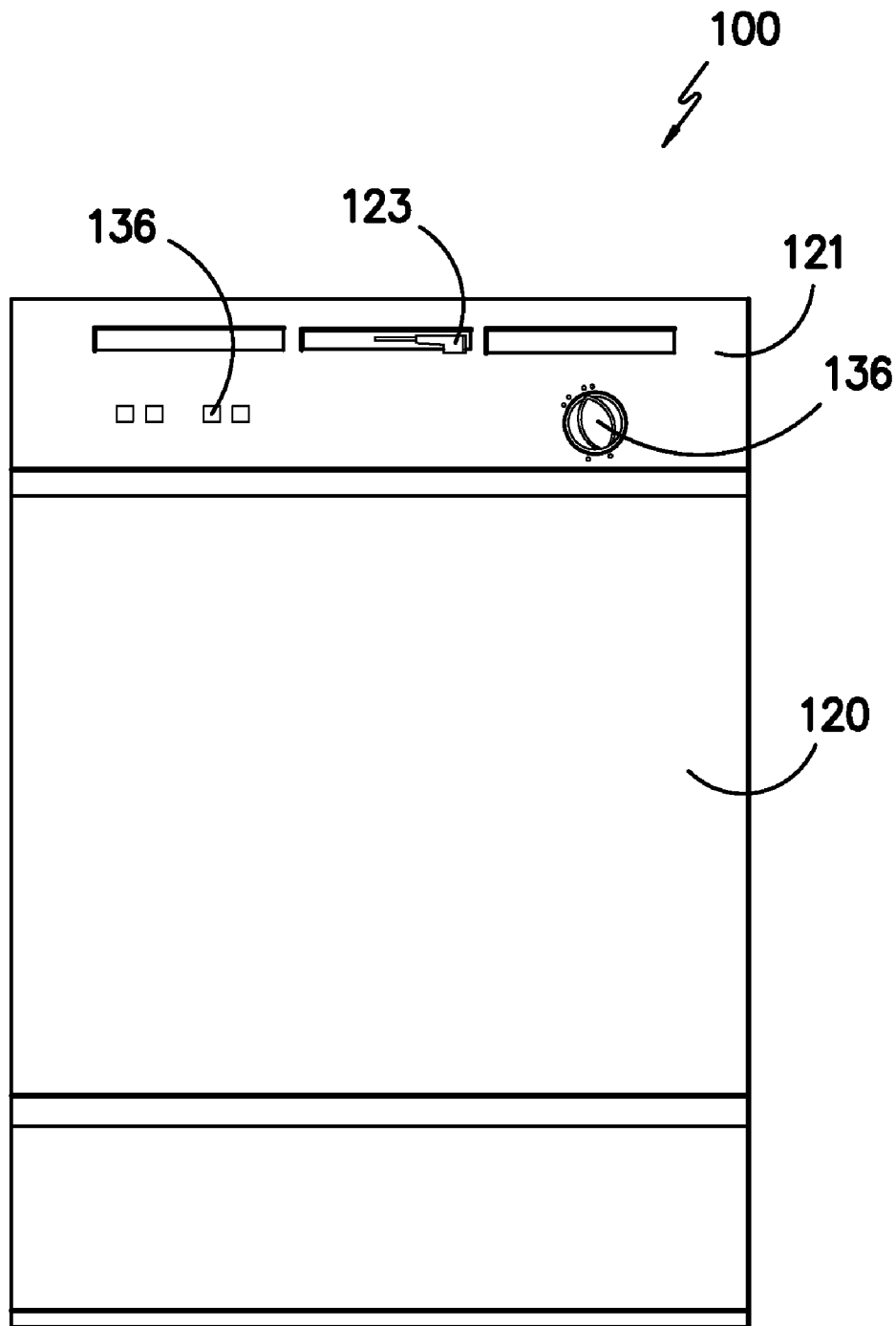

FIG. -1-

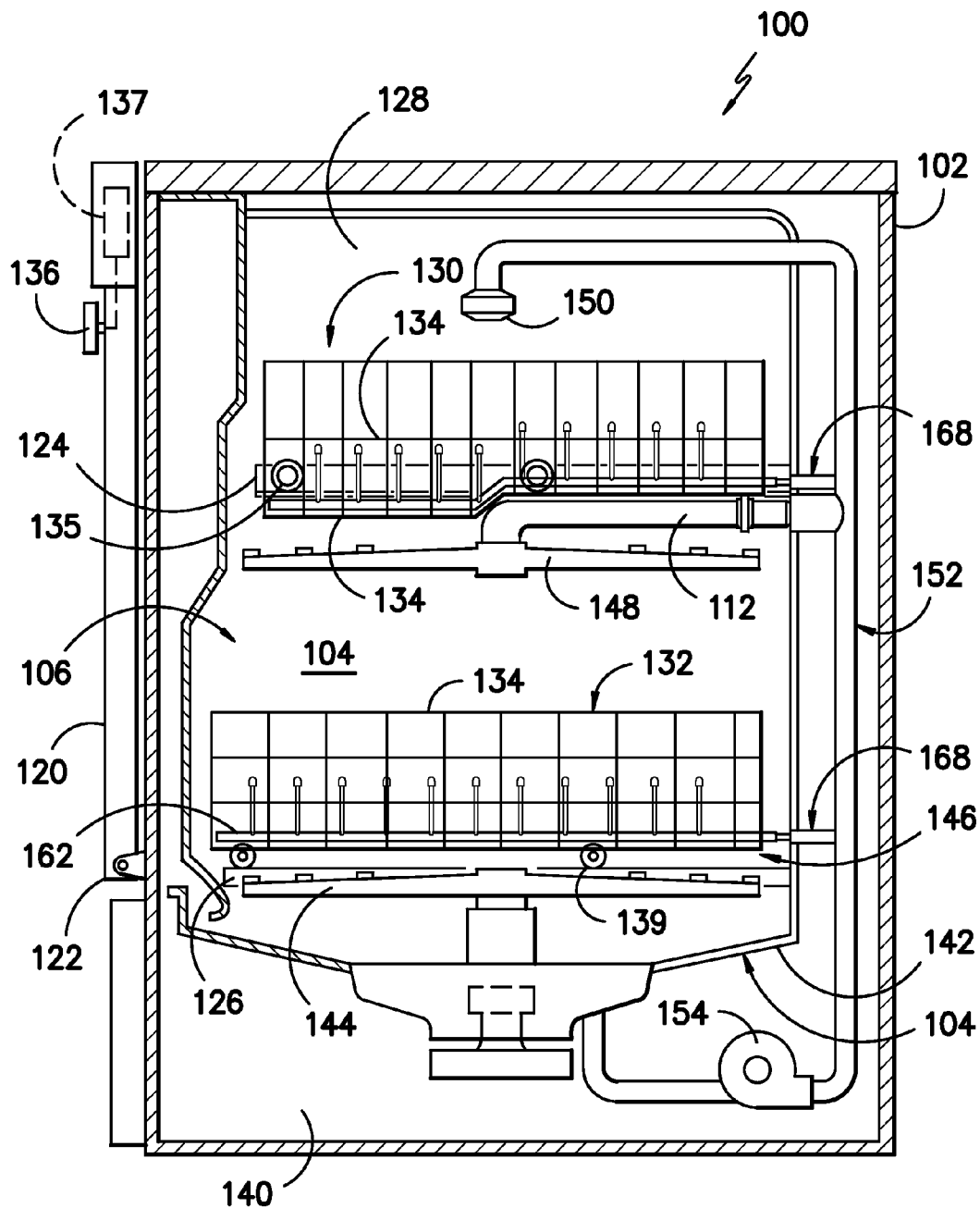

FIG. -2-

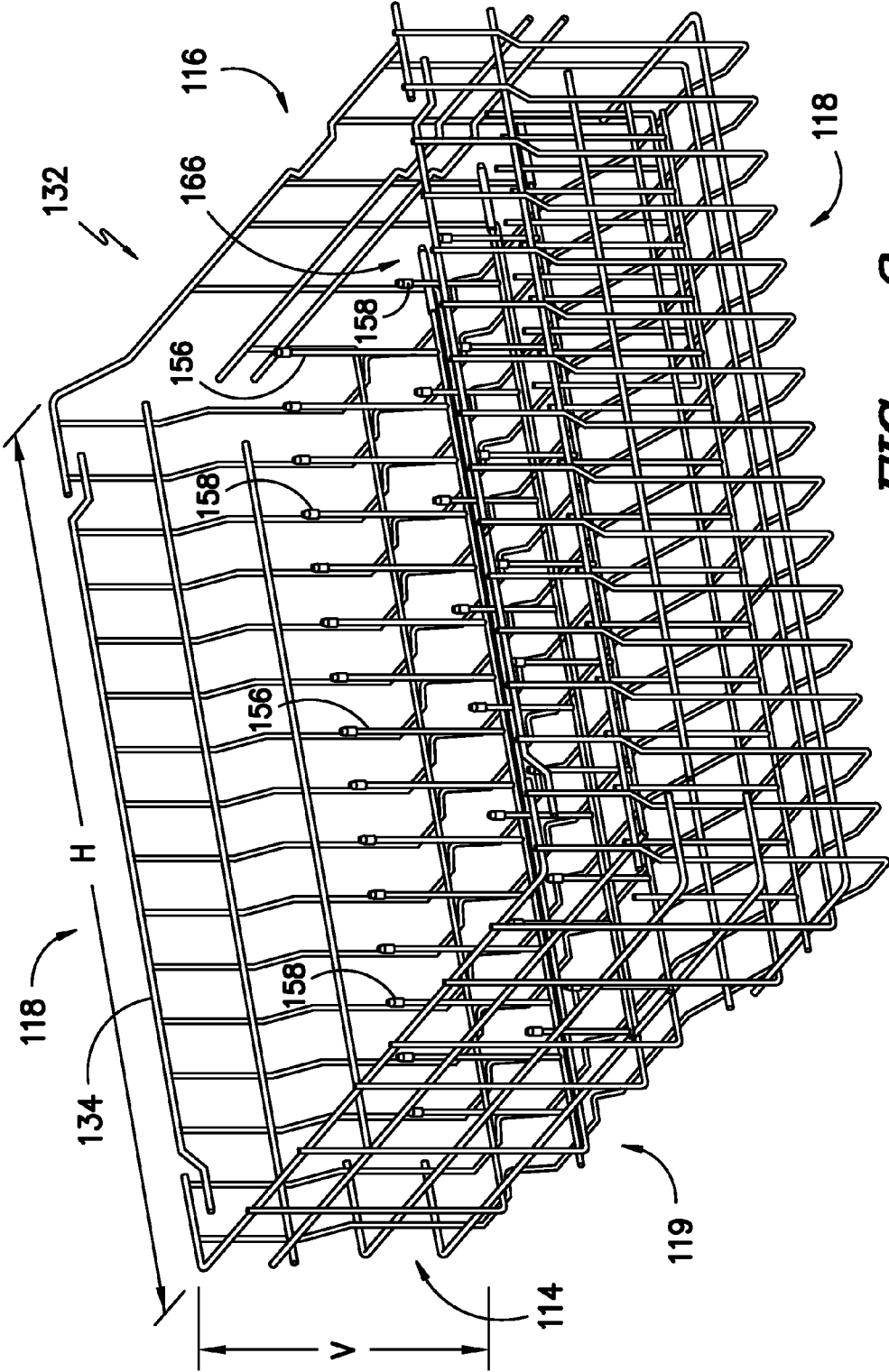

FIG. -3-

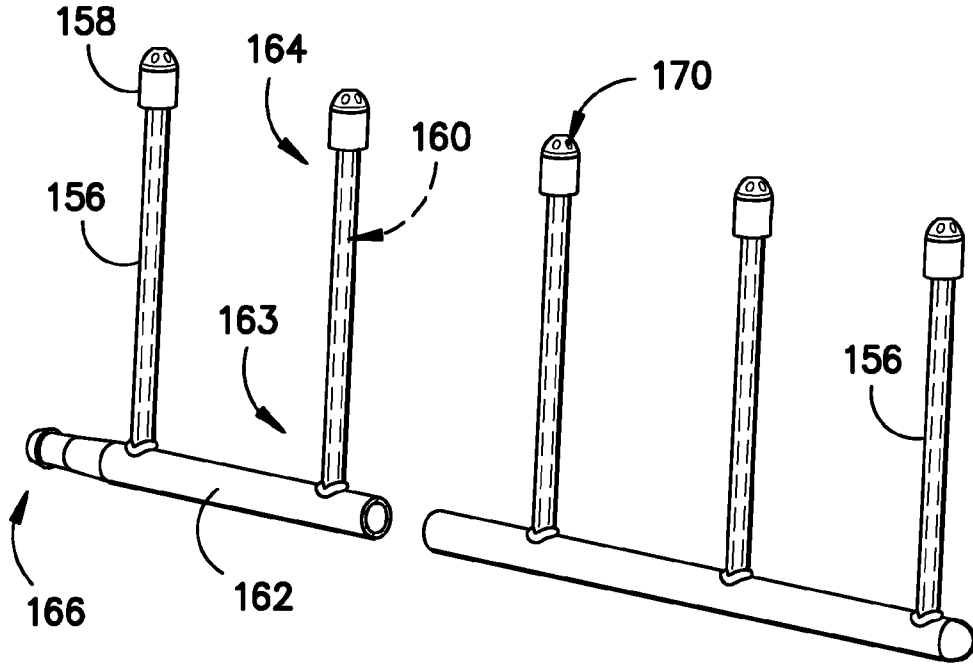

FIG. -4-

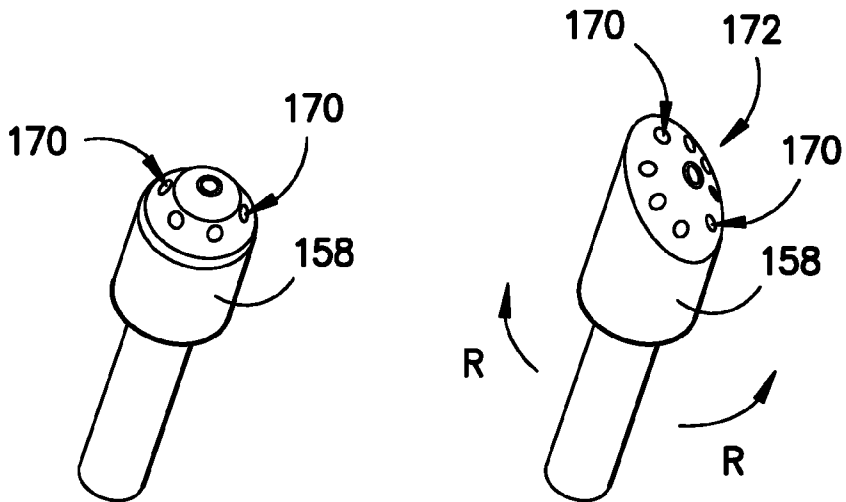

FIG. -5-

FIG. -6-

SPRAY TINES FOR A DISHWASHER RACK

FIELD OF THE INVENTION

[0001] The present invention relates to tines for the rack of dishwasher appliance that can provide a spray for cleaning dishes, particularly the interior of containers such as glasses, cups, bowls, and others.

BACKGROUND OF THE INVENTION

[0002] Modern dishwashers typically include a wash chamber where e.g., detergent, water, and heat can be applied to clean food or other materials from dishes and other articles being washed. Often an upper rack assembly is disposed close to the top of the washing chamber and is used to hold glasses, cups, and other small items. Typically, a lower rack assembly is positioned near the bottom of the chamber and a considerable distance below the upper rack. This provides vertical clearance to place dishes and platters on edge (i.e. a vertical orientation) and to place food preparation bowls and pots up-side-down on the lower rack for washing.

[0003] Each rack normally is supplied with an array of spaced apart, generally vertical tines or members, which support and separate the individual items. Preferably, these vertical members support and fix the position of various articles during the washing process. More specifically, it is desirable to position an article, such as a dish, so that water and detergent can access all surfaces during cleaning while also preventing movement of the dish that could lead to breaking, chipping, or other damage.

[0004] Conventionally, water containing detergent, rinse water, and/or other fluids are sprayed onto the dishes by rotating spray arms positioned proximate to the racks. Water is fed to the spray arms from the rear of the dishwasher and the flow of water exiting the arms also provides for the rotation of the arms. As such, the spray arms do not necessarily apply a continuous spray at any one location in the rack and, instead, provide an intermittent spray at a given location as the spray arm rotates proximate to the rack.

[0005] For items having an interior cavity such as tall glasses or other containers, challenges are encountered in effectively cleaning the interior surfaces of the cavity and particularly the bottom of the cavity. Glass and other containers are typically placed upside down on the tines of the rack. As such, fluids are typically only sprayed directly into the interior as a spray arm passes. Depending upon the level of soiling on the interior of the container, such intermittent spraying may not consistently clean all of the interior surfaces. Increasing the wash cycle time may provide improved performance but at additional costs in operating the appliance.

[0006] Accordingly, an apparatus that can provide improved cleaning capability for a dishwasher would be useful. More particularly, a dishwasher having one or more features that can provide a spray, including a continuous spray, into the interior of various containers would be beneficial. The ability to provide options for an omni-directional or focused spray from such features would also be very useful.

BRIEF DESCRIPTION OF THE INVENTION

[0007] Aspects and advantages of the invention will be set forth in part in the following description, or may be obvious from the description, or may be learned through practice of the invention.

[0008] In one exemplary embodiment, the present invention provides a dishwasher rack assembly that includes a plurality of elongated members defining a front wall, a back wall, a pair of opposing side walls, and a bottom wall. A plurality of spray tines is provided. Each tine includes a fluid channel extending between a lower end of the tine and an upper end of the tine. The fluid channel is configured for delivering a fluid to the upper end of the tine so as to provide for a spray of the fluid from the tine.

[0009] In another exemplary embodiment, the present invention provides a dishwasher having a wash chamber for the receipt of dishes. The dishwasher defines vertical and horizontal directions. The dishwasher includes a dishwasher rack assembly movably received into the wash chamber. The dishwasher rack includes a plurality of hollow tines extending upwardly from the rack assembly, each hollow tine defining an interior channel and having a lower end and an upper end. At least one orifice is positioned along the upper end of each of the hollow tines. Each orifice is in fluid communication with the channel of a respective hollow tine.

[0010] These and other features, aspects and advantages of the present invention will become better understood with reference to the following description and appended claims. The accompanying drawings, which are incorporated in and constitute a part of this specification, illustrate embodiments of the invention and, together with the description, serve to explain the principles of the invention.

BRIEF DESCRIPTION OF THE DRAWINGS

[0011] A full and enabling disclosure of the present invention, including the best mode thereof, directed to one of ordinary skill in the art, is set forth in the specification, which makes reference to the appended figures, in which:

[0012] FIG. 1 provides a front, perspective view of an exemplary dishwashing appliance of the present invention.

[0013] FIG. 2 provides a side, cross-sectional view of the exemplary embodiment of FIG. 1.

[0014] FIG. 3 is a perspective view of an exemplary rack assembly of the present invention.

[0015] FIGS. 4-6 provide perspective views of exemplary spray tines and spray tips of the present invention.

DETAILED DESCRIPTION OF THE INVENTION

[0016] The present invention provides tines that can provide a spray into the interior of containers placed onto a rack of a dishwasher. More particularly, the present invention provides hollow tines or tines having an internal fluid path for feeding washing fluid to an opening at or near an upper end of the tine. As the fluid is sprayed or ejected from the opening, it provides for cleaning the interior of glasses, containers, and other dishes placed over the tines. Reference now will be made in detail to embodiments of the invention, one or more examples of which are illustrated in the drawings. Each example is provided by way of explanation of the invention, not limitation of the invention. In fact, it will be apparent to those skilled in the art that various modifications and variations can be made in the present invention without departing from the scope or spirit of the invention. For instance, features illustrated or described as part of one embodiment can be used with another embodiment to yield a still further embodiment. Thus, it is intended that the present invention covers such modifications and variations as come within the scope of the appended claims and their equivalents.

[0017] FIGS. 1 and 2 depict an exemplary domestic dishwasher 100 that may be configured in accordance with aspects of the present disclosure. For the particular embodiment of FIG. 1, the dishwasher 100 includes a cabinet 102 having a tub 104 therein that defines a wash chamber 106. The tub 104 includes a front opening (not shown) and a door 120 hinged at its bottom 122 for movement between a normally closed vertical position (shown in FIGS. 1 and 2), wherein the wash chamber 106 is sealed shut for washing operation, and a horizontal open position for loading and unloading of articles from the dishwasher. Latch 123 is used to lock and unlock door 120 for access to chamber 106.

[0018] Upper and lower guide rails 124, 126 are mounted on tub side walls 128 and accommodate roller-equipped rack assemblies 130 and 132. Each of the rack assemblies 130, 132 is fabricated into lattice structures including a plurality of elongated members 134 (for clarity of illustration, not all elongated members making up assemblies 130 and 132 are shown in FIG. 2). Each rack 130, 132 is adapted for movement between an extended loading position (not shown) in which the rack is substantially positioned outside the wash chamber 106, and a retracted position (shown in FIGS. 1 and 2) in which the rack is located inside the wash chamber 106. This is facilitated by rollers 135 and 139, for example, mounted onto racks 130 and 132, respectively. A silverware basket (not shown) may be removably attached to rack assembly 132 for placement of silverware, utensils, and the like, that are otherwise too small to be accommodated by the racks 130, 132.

[0019] The dishwasher 100 further includes a lower spray-arm assembly 144 that is rotatably mounted within a lower region 146 of the wash chamber 106 and above a tub sump portion 142 so as to rotate in relatively close proximity to rack assembly 132. A mid-level spray-arm assembly 148 is located in an upper region of the wash chamber 106 and may be located in close proximity to upper rack 130. Additionally, an upper spray assembly 150 may be located above the upper rack 130.

[0020] The lower and mid-level spray-arm assemblies 144, 148 and the upper spray assembly 150 are fed by a fluid circulation assembly 152 for circulating water and dishwasher fluid in the tub 104. The fluid circulation assembly 152 may include a pump 154 located in a machinery compartment 140 located below the bottom sump portion 142 of the tub 104, as generally recognized in the art. Each spray-arm assembly 144, 148 includes an arrangement of discharge ports or orifices for directing washing liquid onto dishes or other articles located in rack assemblies 130 and 132. The arrangement of the discharge ports in spray-arm assemblies 144, 148 provides a rotational force by virtue of washing fluid flowing through the discharge ports. The resultant rotation of the lower spray-arm assembly 144 provides coverage of dishes and other dishwasher contents with a washing spray.

[0021] The dishwasher 100 is further equipped with a controller 137 to regulate operation of the dishwasher 100. The controller may include a memory and microprocessor, such as a general or special purpose microprocessor operable to execute programming instructions or micro-control code associated with a cleaning cycle. The memory may represent random access memory such as DRAM, or read only memory such as ROM or FLASH. In one embodiment, the processor executes programming instructions stored in memory. The memory may be a separate component from the processor or may be included onboard within the processor.

[0022] The controller 137 may be positioned in a variety of locations throughout dishwasher 100. In the illustrated embodiment, the controller 137 may be located within a control panel area 121 of door 120 as shown. In such an embodiment, input/output (“I/O”) signals may be routed between the control system and various operational components of dishwasher 100 along wiring harnesses that may be routed through the bottom 122 of door 120. Typically, the controller 137 includes a user interface panel 136 through which a user may select various operational features and modes and monitor progress of the dishwasher 100. In one embodiment, the user interface 136 may represent a general purpose I/O (“GPIO”) device or functional block. In one embodiment, the user interface 136 may include input components, such as one or more of a variety of electrical, mechanical or electro-mechanical input devices including rotary dials, push buttons, and touch pads. The user interface 136 may include a display component, such as a digital or analog display device designed to provide operational feedback to a user. The user interface 136 may be in communication with the controller 137 via one or more signal lines or shared communication busses.

[0023] It should be appreciated that the invention is not limited to any particular style, model, or other configuration of dishwasher, and that the embodiment depicted in FIGS. 1 and 2 is for illustrative purposes only. For example, instead of the racks 130, 132 depicted in FIG. 1, the dishwasher 100 may be of a known configuration that utilizes drawers that pull out from the cabinet and are accessible from the top for loading and unloading of articles. Other configurations may be used as well.

[0024] FIG. 3 provides a perspective view of a rack assembly 132 with more details for elongated members 134 than is illustrated in FIG. 2. More specifically, rack assembly 132 includes a plurality of elongated members 134 that define a front wall 114, a rear wall 116, a pair of opposing side walls 118, and a bottom wall 119. Rack assembly 132 is provided by way of example only; other constructions may be used with the present invention as well.

[0025] Rack assembly 132 includes a plurality of tines 156, each equipped with a spray tip 158. As shown in FIG. 4, each tine 156 is hollow and defines a fluid channel 160 extending between a lower end 163 and an upper end 164 of each tine 156. As such, the fluid channel 160 provides for the flow of a wash or rinse fluid from a supply conduit 162, to which the lower end 163 of each tine 156 is attached. As such, tine 156 can provide a constant spray of fluid against the interior of a glass or other container into which tine 156 is placed.

[0026] Supply conduit 162 includes a connecting end 166 configured for mating connection with a docking port 168 (FIG. 2) located at the rear of dishwasher 100. Port 168 is connected with fluid circulation assembly 152 such the wash and/or rinse fluids may be supplied to tines 156.

[0027] Supply conduit 162 can be provided as a separate element that is positioned near the bottom wall 119 of rack assembly 132 as shown in FIGS. 2 and 3. However, other constructions may be used as well. For example, supply conduit 162 could be constructed to appear as one of the elongated elements 134 that creates walls 118 or 119 of rack assembly 132.

[0028] Continuing with FIGS. 4 and 5, each spray tip 158 defines a plurality of orifices 170 that help create a spray of fluid. A variety of patterns may be used for orifices 170. As shown in FIG. 5, orifices 170 may be uniformly positioned

about spray tip **158** to provide an omni-directional spray of fluid. Alternatively, as shown in FIG. **6**, spray tip **158** may be provided with an angled face **172** to provide a spray substantially along a direction selected by e.g., the user. For additional flexibility, spray tip **158** may be configured for rotation (arrows R in FIG. **6**) whereby e.g., the user may select a desired direction of the spray from tip **158**. A variety of other configurations for providing various patterns and adjustability from spray tips **158** may be used as well. For example, spray patterns may include cone jet, hollow cone jet, pencil jet, fan jet, and others as well.

[0029] As shown in FIGS. **4-6**, spray tips **158** are provided as caps that are positioned onto tines **156**. However, other constructions may also be employed. For example, spray tips **158** may be molded integrally with tines **156** or provided with connectors for attachment to tines **156**. Alternatively, in another embodiment of the invention, spray tips **158** may be avoided altogether by equipping tines **156** with one or more orifices positioned at or near the upper end **164** of tine **156**. As such, a fluid provided by channel **160** may be sprayed directly from such orifice(s) in tine **156**. Tips **158** may also be constructed in a variety of shapes and are not limited to the shapes shown in the figures.

[0030] As described above, fluid supply conduit **162** is provided with fluid by direction connection to fluid circulation assembly **152**. In an alternative embodiment of the present invention, fluid supply conduit **162** may be connected to e.g., a manifold **112** supplying fluid to spray arm assembly **148**. As such, the connecting end of supply conduit **166** and port **168** would be eliminated and a tube or other conduit would be used to connect with manifold **112** with is in turn connected to fluid circulation assembly **152**.

[0031] Fluid circulation assembly **152** is used to recirculate wash or rinse fluids through dishwasher **100** for a predetermined period of time in order to effectively wash or rinse the dishes. Tines **156** provide for the placement of a spray of such fluid into the interior of containers that have been placed onto rack assembly **132** in order to provide more effective cleaning and rinsing than may occur through use of spray arm **148** alone. In still another embodiment of the invention, fluid supply conduit **162** can be supplied with a source of fresh water rather than with fluids recirculated through assembly **152**. For example, a valve (not shown) can be used to control the flow of fresh water or other non-recirculated fluid into fluid supply conduit **162**. Such an option might be desirable during the initial filling of chamber **106** in preparation for washing—thereby simultaneously serving to help clean the interior of various containers and other dishes. Alternatively, it may be desirable to introduce fresh water in such fashion during part of a rinse cycle. Other variations may be used as well.

[0032] This written description uses examples to disclose the invention, including the best mode, and also to enable any person skilled in the art to practice the invention, including making and using any devices or systems and performing any incorporated methods. The patentable scope of the invention is defined by the claims, and may include other examples that occur to those skilled in the art. Such other examples are intended to be within the scope of the claims if they include structural elements that do not differ from the literal language of the claims, or if they include equivalent structural elements with insubstantial differences from the literal languages of the claims.

What is claimed is:

1. A dishwasher rack assembly, comprising:

a plurality of elongated members defining a front wall, a rear wall, a pair of opposing side walls, and a bottom wall; and,

a plurality of spray tines, each said tine comprising a fluid channel extending between a lower end of said tine and an upper end of said tine, the fluid channel configured for delivering a fluid to the upper end of said tine so as to provide a spray of the fluid.

2. A dishwasher rack assembly as in claim 1, further comprising a plurality of spray tips, each said tip positioned at the upper end of one of said spray tines, each said spray tip defining at least one orifice for delivering a spray of fluid supplied from the fluid channel of a said spray tine.

3. A dishwasher rack assembly as in claim 2, further comprising a fluid supply conduit, wherein the lower end of each of said plurality of tines is connected to said fluid supply conduit.

4. A dishwasher rack assembly as in claim 3, wherein said fluid supply conduit extends along the bottom wall defined by said plurality of elongated members.

5. A dishwasher rack assembly as in claim 3, wherein said fluid supply conduit is configured with a connecting end for mating connection with a docking port along a wall of a dishwasher so as to provide a fluid to said fluid supply conduit.

6. A dishwasher rack assembly as in claim 2, wherein each said spray tip comprises a cap that is attached onto the upper end of one of said spray tines.

7. A dishwasher rack assembly as in claim 2, wherein each said spray tip defines a plurality of orifices for delivering the spray of fluid from the fluid channel of a said spray tine.

8. A dishwasher rack assembly as in claim 7, wherein the plurality of orifices of at least one of said spray tips is positioned so as to provide an omni-directional spray of fluid from the at least one said spray tip.

9. A dishwasher rack assembly as in claim 2, wherein the spray tip of at least one of said plurality of spray tines is rotatable such that the direction of fluid flowing from said spray tip may be adjusted by a user of the dishwasher rack assembly.

10. A dishwasher rack assembly as in claim 2, wherein said dishwasher rack assembly further comprises:

a spray arm assembly attached to the bottom wall of the rack assembly; and,

a manifold for supplying fluid to said spray arm assembly and said plurality of spray tines;

wherein the lower end of each of said plurality of tines is connected to a fluid supply conduit, and wherein said fluid supply conduit is connected with said manifold.

11. A dishwasher having a wash chamber for the receipt of dishes, the dishwasher defining vertical and horizontal directions, the dishwasher comprising:

a dishwasher rack assembly movably received into the wash chamber, the dishwasher rack assembly comprising:

a plurality of hollow tines extending upwardly from the rack assembly, each said hollow tine defining an interior channel and having a lower end and an upper end; and,

at least one orifice positioned along the upper end of each of said hollow tines, each said orifice in fluid communication with the channel of a respective said hollow tine.

12. A dishwasher as in claim **11**, further comprising: a hollow, elongated fluid supply member extending along said dishwasher rack assembly;

wherein the lower end of each of said plurality of hollow tines is connected to said elongated fluid supply member.

13. A dishwasher as in claim **12**, wherein said elongated fluid supply member is connected with a source of fresh water.

14. A dishwasher as in claim **12**, further comprising: a port located on a rear wall of said dishwasher; and, a connector positioned along one end of said elongated fluid supply member, said connector configured for mating receipt with said port so as to provide for a supply of fluid to said plurality of hollow tines.

15. A dishwasher as in claim **12**, further comprising: a fluid supply manifold attached to a bottom wall of said dishwasher rack assembly; and,

a spray arm assembly located below said dishwasher rack assembly and connected with said fluid supply manifold such that fluid may be provided to said spray arm assembly;

wherein said plurality of hollow tines are also connected with said fluid supply manifold such that fluid may also be provided to said plurality of hollow tines.

16. A dishwasher as in claim **12**, wherein said at least one orifice positioned along the upper end of each of said hollow tines comprises a plurality of orifices providing an omnidirectional spray pattern.

17. A dishwasher as in claim **12**, wherein said at least one orifice positioned along the upper end of each of said hollow tines comprises a plurality of orifices, wherein said orifices may be oriented to provide a spray pattern as selected by a user of the dishwasher.

18. A dishwasher as in claim **17**, wherein said plurality of orifices are configured to provide a spray pattern selected from the group comprising cone jet, hollow cone jet, pencil jet, or fan jet.

19. A dishwasher as in claim **12**, wherein said at least one orifice positioned along the upper end of each of said hollow tines is defined by a cap positioned along the upper end.

20. A dishwasher as in claim **19**, wherein said cap is rotatable about the upper end.

* * * * *