

Sept. 4, 1928.

1,683,292

J. W. HELTZEL

METHOD OF AND MEANS FOR GROOVING PLASTIC MATERIAL

Filed March 11, 1926

3 Sheets-Sheet 1

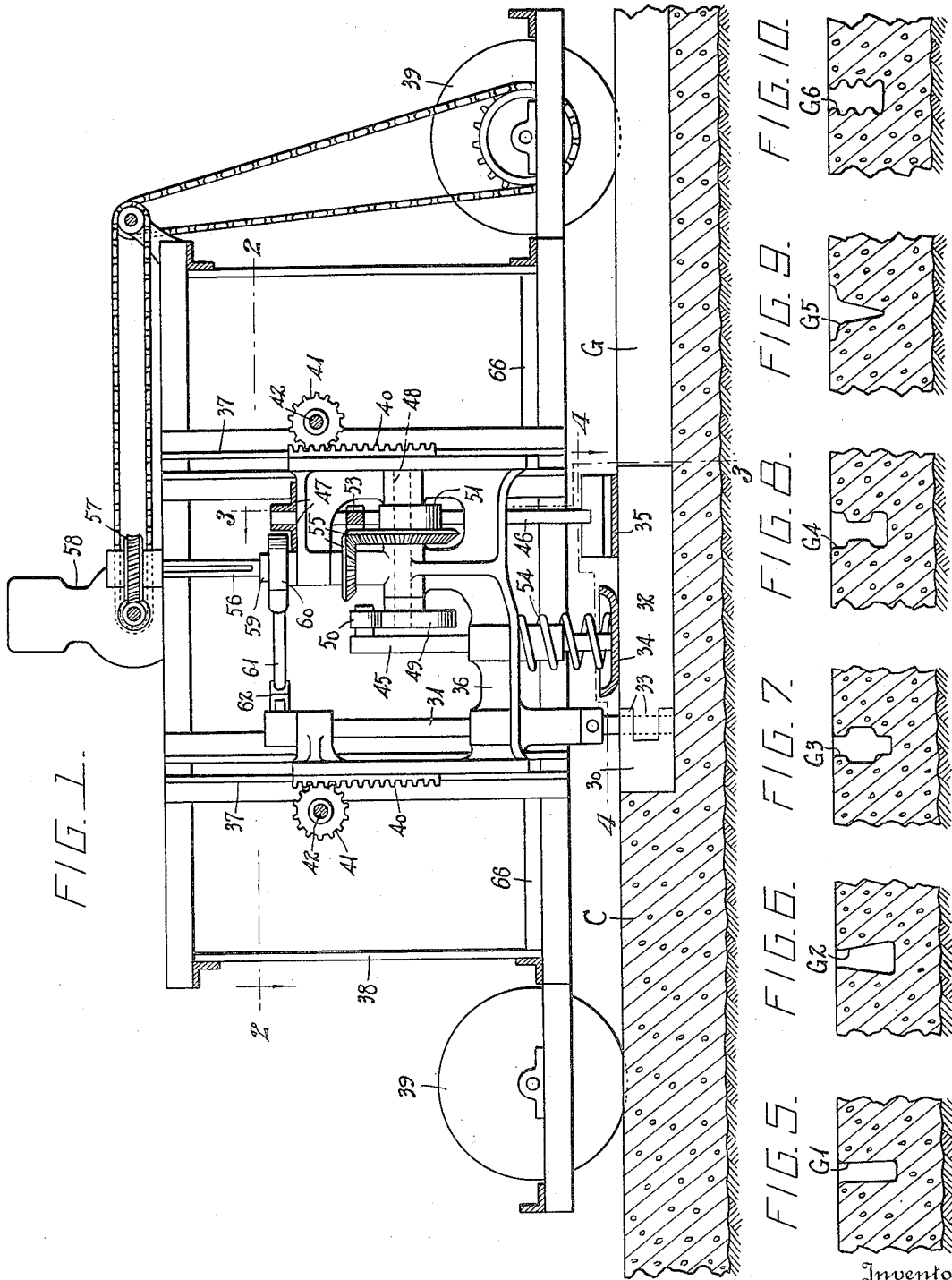

Inventor:

J. W. Heltzel  
Mourer & Miller

By

Attorney.

Sept. 4, 1928.

1,683,292

J. W. HELTZEL

METHOD OF AND MEANS FOR GROOVING PLASTIC MATERIAL

Filed March 11, 1926

3 Sheets-Sheet 2

FIG. 2.

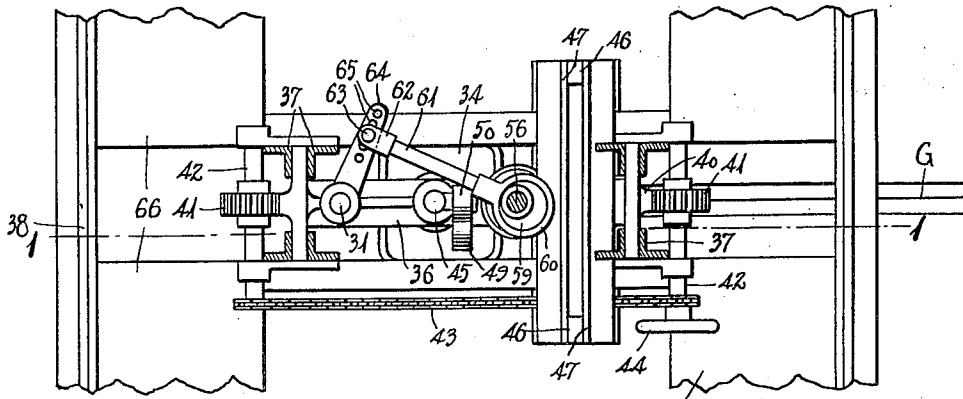

FIG. 3.

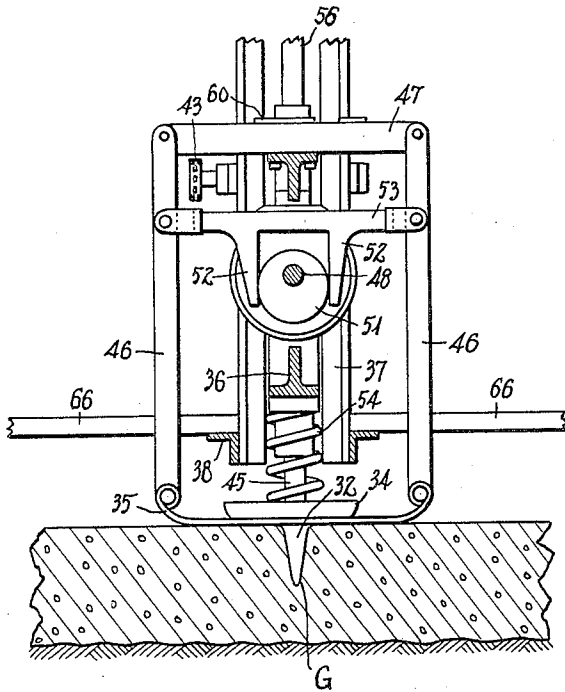

FIG. 4.

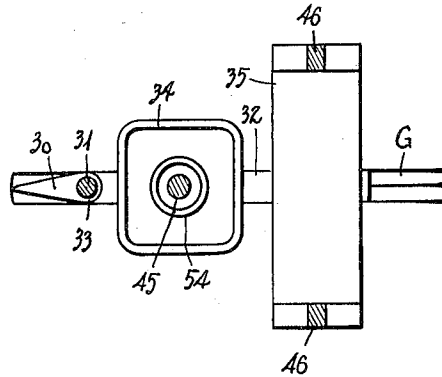

FIG. 11.

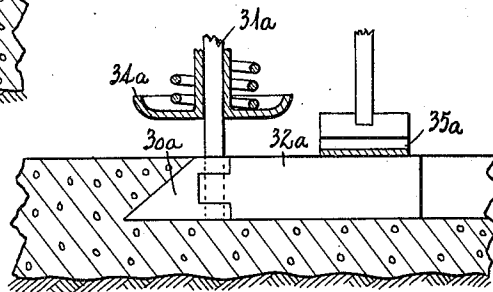
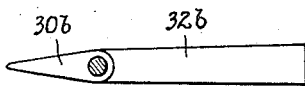

FIG. 12.



Inventor:

*J. W. Heltzel*  
 By *Monroe C. Miller*

Attorney.

Sept. 4, 1928.

1,683,292

J. W. HELTZEL

METHOD OF AND MEANS FOR GROOVING PLASTIC MATERIAL

Filed March 11, 1926

3 Sheets-Sheet 3

FIG. 16.

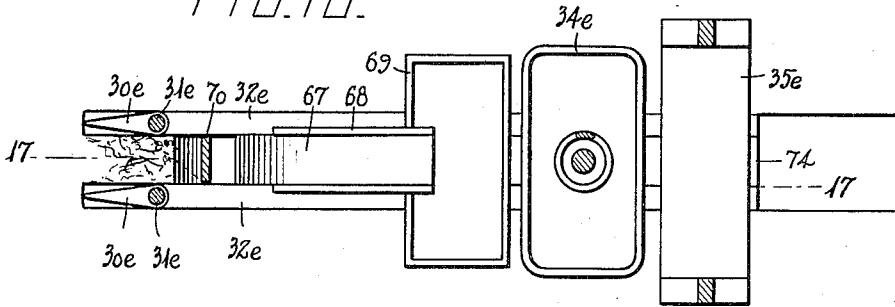

FIG. 17.

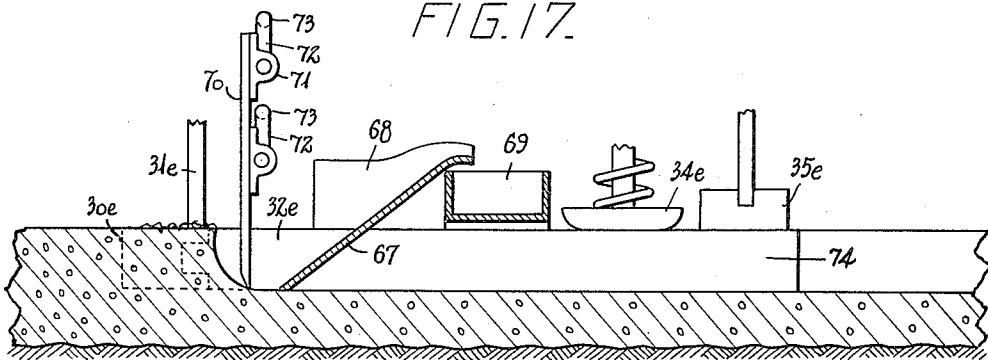

FIG. 13.

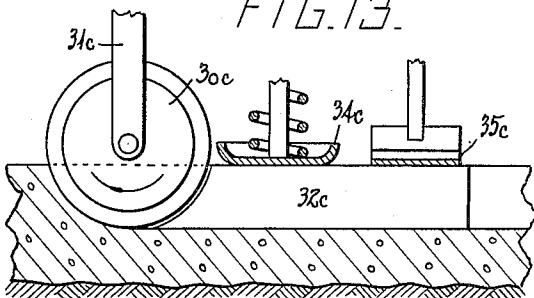

FIG. 18.

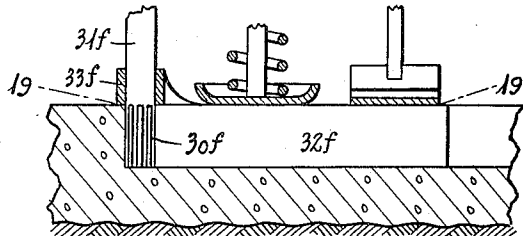

FIG. 14.

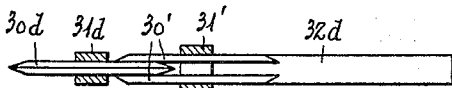

FIG. 19.

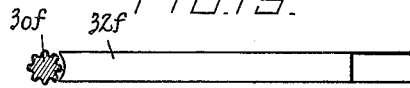

FIG. 15.

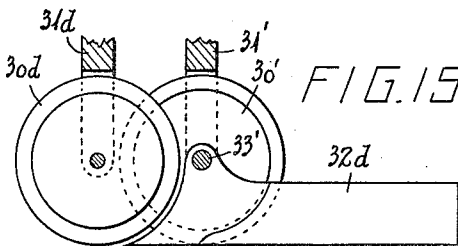
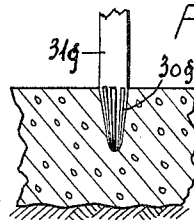

FIG. 20.



Inventor:

J. W. Heltzel  
Morris Miller

By

Attorney.

# UNITED STATES PATENT OFFICE.

JOSEPH WILLIAM HELTZEL, OF WARREN, OHIO.

METHOD OF AND MEANS FOR GROOVING PLASTIC MATERIAL.

Application filed March 11, 1926. Serial No. 93,978.

The present invention relates to the production of grooves in plastic concrete or similar material, and aims to provide a novel and improved method of and means for grooving the plastic material, the invention being particularly suitable and intended for the production of a joint or traffic line in a concrete road or similar surfacing structure.

Another object of the invention is to provide means operable in a novel manner in the plastic material when propelled or advanced therein, to form a groove of the desired shape in the material.

A further object is the provision of such means in combination with means for finishing the surface of the material along the opposite sides or edges of the groove, so that the material is finished both within the groove and on the surface along the groove.

With the foregoing and other objects in view, which will be apparent as the invention is better understood from the following description, the invention resides in the method hereinafter described and the means for carrying out the method, it being understood that changes may be made within the scope of what is hereinafter claimed, without departing from the spirit of the invention.

The invention is illustrated in the accompanying drawings, wherein—

Figure 1 is a vertical section of a machine embodying the grooving device, portions being shown in section on the line 1—1 of Fig. 2, and portions being shown in elevation.

Fig. 2 is a horizontal section on the line 2—2 of Fig. 1.

Fig. 3 is a vertical section on the line 3—3 of Fig. 1.

Fig. 4 is a horizontal section on the line 4—4 of Fig. 1.

Figs. 5, 6, 7, 8, 9 and 10 are cross-sections showing different forms of grooves that can be produced with the invention.

Fig. 11 is a detail view, partly in elevation, and partly in section, of a modified form of grooving device.

Fig. 12 is a top plan view showing still another modification.

Fig. 13 is a detail view, corresponding with Fig. 11, illustrating a further modification.

Fig. 14 is a plan view of another grooving device.

Fig. 15 is a side elevation of the device shown in Fig. 14, portions being removed and shown in section.

Fig. 16 is a plan view of a device embodying the improvements for producing a wide groove.

Fig. 17 is a section on the line 17—17 of Fig. 16.

Fig. 18 is a side elevation, with portions shown in section, illustrating still another grooving device.

Fig. 19 is a section on the line 19—19 of Fig. 18.

Fig. 20 is a side elevation of a further modification in the grooving device.

Reference being had to Figs. 1, 2, 3 and 4, the grooving device comprises a plow or cutter 30 projecting forwardly, or in the direction of movement of the device, and a mandrel or form member 32 trailing immediately in rear of said plow. Said plow and mandrel 32 have the eyes 33 at their adjacent ends embracing a vertical rock shaft 31, and the plow 30 is secured rigidly to said shaft to oscillate therewith, while the forward end of the mandrel 32 loosely engages said shaft. The plow 30 is tapered forwardly so as to be of wedge form, with its forward end rather sharp so as to cut into the concrete or other plastic material in which the grooving device is operated.

A tamper 34 is reciprocated vertically above the mandrel 32, and a transverse belt 35 of leather, cloth or other suitable flexible material is reciprocated transversely over the mandrel 32 in rear of the tamper 34, for tamping and belting the surface of the concrete at the opposite sides of the mandrel.

The grooving device, as described up to this point, may be operated by any suitable mechanism, either manually, or as a part of a power-driven machine. Thus, as the device is propelled or moved forwardly in the concrete, the shaft 31 is rocked or oscillated and the tamper 34 and belt 35 are operated. The plow or cutter 30 having a lateral wiggling or vibratory motion, while advancing slowly in the concrete, will not only cut into the concrete as it moves forwardly, but will also, in forming a groove, work the material toward opposite sides. This action of the plow or cutter is of advantage in order that stones or large pieces of aggregate in the concrete or material, when encountered by the plow or cutter, will be worked toward one side or the other. Thus, should the forward end of the plow contact with a large fragment of stone, the lateral movement of the plow will work such stone to one side

or the other out of the line of movement of the grooving device. Thus, the lateral vibratory or oscillatory movement of the plow enables it to cut forwardly through the material, in an efficient manner. The mandrel or form member 32 follows or trails in rear of the plow to hold the groove open and form the sides or walls of the groove, and the surface of the concrete along the edges or sides of the groove is finished by the tamper 34 and belt 35. The tamper tamps the concrete down by a vertical vibratory motion to pack the concrete at the opposite sides of the mandrel 32 and groove, and the belt 35 is reciprocated across the mandrel 32 for finishing off the surface of the concrete. Such grooving device carries out the method by the vibratory motion of the plow or cutter as it moves in the material followed by the mandrel or form member to hold the groove open and form the sides thereof.

The grooving device operates in the concrete while it is still in a plastic state, and an asphalt, bituminous, colored concrete or other suitable filler may be deposited or placed in the groove in rear of the mandrel 32, so as to fill the groove and complete the joint, which may also serve as a traffic line at the center of a road for dividing traffic moving in opposite directions. It is also possible to place sections of solid material in the groove in rear of the device, to produce the joint and traffic line, or form members may be placed in the groove so as to remain therein until the concrete has hardened, after which said form members may be removed and the groove filled by either plastic or solid material. It is also possible to inject the solid or plastic material into the groove at the rear end of the mandrel 32, such as disclosed in the pending application of John N. Heltzel, Serial No. 24,801, filed April 21, 1925. The device may be used for producing a longitudinal joint or traffic line, or a combined joint and traffic line, at the center of a concrete road, and may also be used for producing transverse joints in the road.

The opposite sides of the mandrel or form member 32 may also be of different shapes to produce grooves of different cross-sections. As shown in Fig. 3, the mandrel 32 produces a V-shaped groove G. As shown in Fig. 5, the groove G<sup>1</sup> has parallel vertical sides, whereas, as shown in Fig. 6, the groove G<sup>2</sup> has its side walls overhanging the bottom, the groove being wider at the bottom than at the mouth thereof. Fig. 7 shows the groove G<sup>3</sup> with supplementary grooves in its sides so that the filler within the groove will have a tongue and groove connection with the opposite sections or slabs of concrete, the same as shown in Fig. 8, wherein the groove G<sup>4</sup> has ribs or tongues at opposite sides. The groove G<sup>5</sup> shown in Fig. 9 is V-shaped

with a wide mouth to provide a wide traffic line. Fig. 10 illustrates the groove G<sup>6</sup> having longitudinally extending corrugations at opposite sides. When the concrete hardens, the sections or slabs at the opposite sides of the groove being subjected to considerable pressure owing to traffic, and the heaving action of the ground during changes in seasons, will crack or fracture below the groove, which is the weakest portion of the concrete. The filler in the groove serves to seal the joint, and the cracks will occur along the groove below the filler, thus providing an even joint without irregular breaking of the concrete at the surface thereof, such as occurs when the concrete is allowed to break without control. The filler may be of various kinds, such as asphalt, tar, or the like, poured or injected into the groove, or concrete of a different color may be used to produce a traffic line. A solid filler of metal, paper, wood or other material may also be used. The groove may be filled immediately in rear of the mandrel 32 with the permanent filler, or may be held open by forms, especially if the material has not set sufficiently and is still mobile, until the material has been set, when the forms may be removed and the groove filled. The grooving device thus has a wide range of use.

The grooving device is embodied in a machine, as shown, and such machine includes a vertically movable slide or carrier 36 movable within vertical guides 37 of the frame 38 having supporting wheels 39 to mount the machine for movement over the concrete or material. The wheels 39 may move on the side rails or form members usually employed, as well known, for defining the edges or sides of a concrete road under construction, for mounting the grooving device for movement longitudinally along a road after the concrete has been poured and finished off. However, the device may be mounted for movement over the material in any suitable manner.

The slide or carrier 36 has racks 40 meshing with pinions 41 secured on shafts 42 mounted in the frame 38. Said shafts are connected by an endless sprocket chain 43, and one shaft has a handle wheel 44 whereby the carrier 36 may be readily moved upwardly and downwardly to retract the grooving device from and depress it into the material, respectively.

The shaft 31 is journaled in the carrier 36 to move upwardly and downwardly therewith, and the tamper 34 has a shank or stem 45 slidable vertically in the carrier. The ends of the belt 35 are connected in any suitable manner to the lower ends of a pair of pendulums or pendent levers 46 which are fulcrumed at their upper ends to a yoke 47 secured on the carrier 36, so that the belt 35 is also supported by the carrier to

be raised and lowered therewith. The tamper 34 and belt 35 also bear on the mandrel or follower 32 so as to be raised therewith when the carrier 36 is raised to raise the shaft 31 and plow 30.

The actuating means for the plow 30, tamper 34 and belt 35 includes a horizontal shaft 48 journaled in the carrier 36 and having a cam 49 movable under a roller 50 carried by the stem 45 of the tamper, whereby the cam raises the tamper and then releases same for downward movement. A coiled spring 54 is confined between the tamper 34 and carrier 36 to forcibly depress the tamper so that it impinges against the concrete or material at opposite sides of the mandrel 32 with a sharp blow. An eccentric 51 is secured on the shaft 48 and is disposed between the depending arms 52 of a link 53 connecting the pendulums 46, so that the rotation of said shaft will oscillate the pendulums 46 and thereby reciprocate the belt 35 transversely over the mandrel 32. The shaft 48 is connected by bevel ears 55 with a vertical shaft 56 having its lower terminal journaled in the carrier 36, and the upper terminal of said shaft is slidable through and rotatable with a gear wheel 57 mounted on the frame 38 and operatively connected with an engine 58 or other prime mover mounted on the frame to furnish the power, it being understood that any suitable clutch or other controlling means may be used for starting and stopping the shaft 56, and that the engine 58 may also furnish the power to propel the machine. An eccentric 59 is secured on the shaft 56 and is embraced by a band 60 connected by a bar or link 61 with an arm 64 secured to the shaft 31. The bar 61 has a fork 62 straddling the arm 64, and the pivot 63 between said bar and arm may be adjusted in the apertures 65 in the arm 64 to change the angle of oscillation of the shaft 31 and plow 30. This enables the lateral movement of the plow to be regulated.

In the operation of the machine, the rotation of the shaft 56 will drive the rock shaft 31 so as to oscillate or vibrate the plow 30, and the tamper 34 and belt 35 are also operated at a suitable speed from the shaft 48, it being preferable to operate the plow 30 with a rapid vibratory motion, whereas the tamper 34 and belt 35 may operate at a slower speed. The speed of the plow, tamper and belt are determined by the conditions.

The frame 38 has mounted therein or carried thereby platforms or running boards 66 on which workmen may stand for finishing the surface of the concrete in front or in rear of the grooving device, or for the purpose of placing the filling in the groove. The platforms 66 are preferably spaced apart above the line of the groove to permit access

to the concrete immediately in front and in rear of the grooving device.

Fig. 11 shows the plow or cutter 30<sup>a</sup> having its forward edge inclined rearwardly, thereby having a tendency to raise large fragments of stone up to the surface. The tamper 34<sup>a</sup> is shown as being movable on the rock shaft 31<sup>a</sup> which carries the plow 30<sup>a</sup>, and the belt 35<sup>a</sup> moves across the mandrel 32<sup>a</sup>.

Fig. 12 illustrates the mandrel or form member 32<sup>b</sup> as increasing in width rearwardly from the plow or cutter 30<sup>b</sup>, in order that said mandrel may separate or spread the material to widen the groove.

Fig. 13 illustrates a disk 30<sup>c</sup> mounted for rotation in the lower terminal of the shaft 31<sup>c</sup>, with the lower portion of the disk entering the material to serve as the plow or cutter, which may be oscillated with the shaft 31<sup>c</sup>. The disk 30<sup>c</sup> is preferably rotated so that its lower portion moves in the direction of travel, as indicated by the arrow. The mandrel 32<sup>c</sup> follows in rear of the disk and the tamper 34<sup>c</sup> and belt 35<sup>c</sup> operate over said mandrel. The disk 30<sup>c</sup> may be rotated by any suitable mechanism (not shown).

Figs. 14 and 15 illustrate a disk 30<sup>d</sup> mounted for rotation in the lower terminal of the shaft or hanger 31<sup>d</sup>, with its rear portion disposed between a pair of disks 30<sup>e</sup> mounted for rotation on an axle 33<sup>e</sup> carried by the lower terminal of a hanger 31<sup>e</sup>. Said disks cut the material, the disk 30<sup>d</sup> having a double bevelled edge so as to cut into the material, and the disks 30<sup>e</sup> having bevels at their opposite sides to widen the groove, with their inner or adjacent sides overlapping the sides of the front disk 30<sup>d</sup>. The mandrel or follower 32<sup>d</sup> projects between the disks 30<sup>e</sup> to the disk 30<sup>d</sup> and engages the axle 33<sup>e</sup> so as to trail in rear of the disk 30<sup>d</sup>.

Figs. 16 and 17 illustrate a grooving device adapted especially for producing a wide groove. Thus, transversely spaced plows or cutters 30<sup>e</sup> are secured to the lower ends of parallel vertical shafts 31<sup>e</sup>, and the followers or mandrel bars 32<sup>e</sup> trail in rear of the plows 30<sup>e</sup>. The plows and followers may be spaced apart any desired distance, according to the width of groove to be made, and means is provided for removing the material from between the followers 32<sup>e</sup>. Thus, an inclined deflector 67 extends downwardly between the followers 32<sup>e</sup> and has side flanges 68 above said followers so that the material is reflected upwardly by said deflector to drop into a suitable receptacle 69, in order that the material may be readily removed. The material may be loosened and fed rearwardly to and upwardly along the deflector 67 by means of a digger blade 70. As shown, said blade has bearings 71 engaging the cranks 72 of vertically spaced shafts 73 which, when rotated, will give the lower terminal of the blade a

motion to accomplish the desired results. Thus, the blade is moved downwardly into the material between the followers 32<sup>e</sup>, rearwardly toward the deflector 67, upwardly to  
 5 withdraw the blade from between the followers, and then forwardly. Thus, the blade cuts down into the material, as the device is advanced, and loosens the material and delivers same rearwardly to and upwardly  
 10 along the deflector 67. The tamper 34<sup>e</sup> and belt 35<sup>e</sup> operate over the followers 32<sup>e</sup> in rear of the receptacle 69, and a spacer 74 is secured between the followers 32<sup>e</sup> in rear of the deflector 67, so that said followers  
 15 will define the sides or walls of the groove.

Fig. 18 illustrates the shaft 31<sup>f</sup> having its lower terminal formed with longitudinal flutes or ribs, as seen in Fig. 19, to operate in the material for cutting the groove. The  
 20 mandrel 32<sup>f</sup> has a collar 33<sup>f</sup> at its forward end embracing the shaft 31<sup>f</sup> above the portion 30<sup>f</sup> of the shaft which forms the plow or cutter. The shaft 31<sup>f</sup> is rotated rapidly in one direction, and then reversely, so as to  
 25 have rotary movement alternately in opposite directions to facilitate the cutting action in the material and to deflect the material to opposite sides of the line of movement of the device.

Fig. 20 illustrates the grooved or fluted lower terminal 30<sup>g</sup> of the shaft 31<sup>g</sup> as being tapered instead of cylindrical as shown in  
 30 Fig. 18.

Having thus described the invention, what is claimed as new is:—

- 35 1. The method of grooving plastic material consisting in advancing a cutting member in the material while moving it transversely of the line of advance movement.
- 40 2. The method of grooving plastic material consisting in advancing a cutting member in the material while it is vibrated transversely of the line of advance movement.
- 45 3. The method of grooving plastic material consisting in advancing a cutting member in the material while oscillating it transversely of the line of advance movement.
- 50 4. The method of grooving plastic material consisting in advancing a cutting member in the material along the surface thereof while oscillating it about a vertical axis with said member projecting forwardly of the line of advance movement.
- 55 5. The method of grooving plastic material consisting in advancing a cutting member in the material while moving it transversely of the line of advance movement and holding the sides of the groove apart for a distance rearwardly from said member.
- 60 6. The method of grooving plastic material consisting in advancing a cutting member in the material while vibrated transversely of the line of advance movement and holding the sides of the groove apart and  
 65 shaping said sides into predetermined form

for a distance rearwardly from said member.

7. A device for grooving plastic material comprising a cutting member, and means for advancing said member in the material and simultaneously moving it transversely of the line of advance movement. 70

8. A device for grooving plastic material comprising a cutting member, and means for advancing said member in the material and simultaneously vibrating said member transversely of the line of advance movement. 75

9. A device for grooving plastic material comprising an oscillatory member, and means for advancing said member in the material and simultaneously oscillating it. 80

10. A device for grooving plastic material comprising a forwardly projecting cutting member, means for advancing said cutting member in the material and oscillating said member simultaneously to vibrate the forward end of said member transversely of the line of advance movement. 85

11. A device for grooving plastic material comprising a cutting member, means for advancing said cutting member in the material and simultaneously moving said member transversely of the line of advance movement, and means following in rear of said member for holding the sides of the groove apart for a distance rearwardly from said member. 90

12. A device for grooving plastic material comprising a cutting member, means for advancing said member in the material and simultaneously vibrating said member transversely of the line of advance movement, and means following in rear of said member for holding the sides of the groove apart and shaping said sides into predetermined form for a distance rearwardly from said member. 100

13. A grooving device for plastic material comprising an oscillatory shaft, and a cutting member carried by the lower terminal thereof to move in the material. 110

14. A grooving device for plastic material comprising a shaft, a cutting member carried by the lower terminal of the shaft to move in the material, and means for moving said shaft along a line of advance movement and for simultaneously oscillating said shaft. 115

15. A grooving device for plastic material comprising a shaft, and a forwardly extending cutting member carried by the shaft to move in the material. 120

16. A grooving device for plastic material comprising a shaft, a forwardly extending cutting member carried by the shaft to move in the material, and means for advancing said shaft along a line of advance movement and for simultaneously oscillating said shaft. 125

17. A grooving device for plastic material comprising a transversely vibratory cut- 130

ting member movable along a line of advance movement in the material, and a mandrel following said member to hold the sides of the groove apart and shape them.

5 18. A grooving device for plastic material comprising a shaft, a cutting member carried by the shaft to move the material, and a mandrel connected to said shaft to trail in rear of said cutting member.

10 19. A grooving device for plastic material comprising a mandrel movable in the material, and a forwardly extending transversely oscillatory cutting member at the forward end of said mandrel.

15 20. A grooving device for plastic material comprising a shaft, a cutting member carried by the shaft and extending forwardly therefrom, and a mandrel connected to the shaft and extending rearwardly therefrom behind said cutting member.

20 21. A grooving device for plastic material comprising a shaft, a cutting member carried thereby to move in the material, a mandrel connected to the shaft to trail in rear of said member, and means for moving the shaft along the shaft to move the cutting member transversely of the line of advance movement.

25 22. A grooving device for plastic material comprising a shaft, a forwardly extending cutting member secured to the shaft to move in the material, a mandrel connected to said shaft to trail in rear of said member, and means for moving the shaft along the material and oscillating said shaft.

30 23. A grooving device for plastic material comprising a mandrel movable in the material, and finishing means for the surface of the material disposed above said mandrel and mounted for movement with reference to the mandrel and material.

35 24. A grooving device for plastic material comprising a mandrel movable in the material, and a tamper disposed above said mandrel and movable with reference to said mandrel and material and operable on the surface of the material at opposite sides of said mandrel.

40 25. A grooving device for plastic material comprising a mandrel movable in the material, and a transversely movable belt operable over said mandrel.

45 26. A grooving device for plastic material comprising a mandrel movable in the material, a tamper operable over said mandrel on the surface of the material, and a belt movable transversely on the surface of the material over the mandrel in rear of the tamper.

50 27. A grooving device for plastic material comprising a cutting member movable in the material, means for advancing said member in the material and operating it transversely of the line of advance movement, a mandrel following said member, and means for finish-

ing the surface of the material and operable over said mandrel.

28. A grooving device for plastic material comprising a shaft, a cutting member carried by said shaft to move in the material, a mandrel connected with said shaft to follow said member, means for moving said shaft along the line of advance movement and oscillating said shaft to oscillate said cutting member, and means for tamping and belting the material and operable over said mandrel.

75 29. A grooving machine for plastic material comprising a carriage movable over the material, a carrier movable upwardly and downwardly within the carriage, a vertical shaft journaled in the carrier, a cutting member carried by the lower terminal of the shaft to move in the material, a mandrel trailing from said shaft in rear of said member, and finishing means carried by said carrier to operate on the surface of the material over said mandrel.

80 30. A grooving machine for plastic material comprising a carriage movable over the material, a carrier movable upwardly and downwardly within the carriage, a vertical shaft journaled in the carrier, a cutting member carried by the lower terminal of the shaft to move in the material, a mandrel trailing from said shaft in rear of said material, a tamper connected to the carrier for vertical motion and operable on the surface of the material over said mandrel, a belt connected to the carrier for transverse movement on the surface of the material over the mandrel in rear of the tamper, and means for operating said shaft, tamper and belt.

85 31. A grooving device for plastic material including means movable in the material, and finishing means movable on the surface of the material relatively to the first-named means above said first named means.

90 32. A grooving device for plastic material comprising means movable in the material to define a groove therein, and tamping means movable upwardly and downwardly above and relatively to said firstnamed means for tamping the material at opposite sides of said firstnamed means.

95 33. A grooving device for plastic material comprising means movable in the material for defining a groove therein, tamping means movable above and relatively to the firstnamed means to operate on the surface of the material, and belting means operable transversely across the firstnamed means in rear of the tamping means.

100 34. A grooving device for plastic material comprising a shaft having a portion at its lower end movable in the material transversely of a line of movement of the shaft over the material.

105 35. A grooving device for plastic material comprising a carriage movable over the material, and a shaft mounted for turning



movement in the carriage and having a portion at its lower end movable in the material transversely of the line of movement of the carriage.

- 5 36. A grooving device for plastic material comprising a mandrel movable in the material, and means operable at the forward end of the mandrel to open up a groove in the material to receive the mandrel.

37. A grooving device for plastic material including means movable in the material to open up a groove therein, and a mandrel trailing in rear of said means to move in the groove. 10

In testimony whereof I hereunto affix my signature. 15

JOSEPH WILLIAM HELTZEL.