



(11) **EP 1 697 222 B1**

(12) **EUROPEAN PATENT SPECIFICATION**

(45) Date of publication and mention of the grant of the patent:
11.07.2012 Bulletin 2012/28

(21) Application number: **04803208.0**

(22) Date of filing: **22.11.2004**

(51) Int Cl.:
B65D 8/04 (2006.01) B65D 25/42 (2006.01)

(86) International application number:
PCT/EP2004/013215

(87) International publication number:
WO 2005/058716 (30.06.2005 Gazette 2005/26)

(54) **RECLOSABLE METAL CONTAINER**

WIEDERVERSCHLIESSBARER METALLBEHÄLTER

CONTENANT METALLIQUE REFERMABLE

(84) Designated Contracting States:
AT BE BG CH CY CZ DE DK EE ES FI FR GB GR HU IE IS IT LI LU MC NL PL PT RO SE SI SK TR

(30) Priority: **17.12.2003 EP 03257941**

(43) Date of publication of application:
06.09.2006 Bulletin 2006/36

(73) Proprietor: **Crown Packaging Technology, Inc**
Alsip, IL 60803-2599 (US)
Designated Contracting States:
AT BE BG CH CY CZ DE DK EE ES FI GB HU IS LI LU PL PT RO SE SK TR

(72) Inventors:
• **DUNWOODY, Paul, Robert**
Wantage
Oxfordshire OX12 9YA (GB)

- **MARRIOTT, Philip, Alan**
Wantage
Oxfordshire OX12 0BH (GB)
- **NAYAR, Sudesh, Kumar**
Swindon
Wiltshire SN1 4JN (GB)
- **PAVELY, Andrew, Philip**
Swindon
Wiltshire SN26 7BJ (GB)

(74) Representative: **Ratliff, Ismay Hilary**
CROWN Packaging UK plc,
Downsview Road
Wantage, Oxfordshire OX12 9BP (GB)

(56) References cited:
EP-A- 0 443 558 DE-A1- 3 005 378
DE-U- 29 980 137 US-A- 2 105 027
US-A- 2 339 763 US-A- 2 864 529
US-A- 4 883 192

EP 1 697 222 B1

Note: Within nine months of the publication of the mention of the grant of the European patent in the European Patent Bulletin, any person may give notice to the European Patent Office of opposition to that patent, in accordance with the Implementing Regulations. Notice of opposition shall not be deemed to have been filed until the opposition fee has been paid. (Art. 99(1) European Patent Convention).

Description

[0001] This invention relates to a reclosable metal container such as a can of steel or aluminium. In particular, but not exclusively, it relates to a bottle-shaped can for packaging beverages.

[0002] So-called "bottle cans" have been proposed in patent applications such as JP-A-2003165539, for example, in which a container body is closed at one end by a can end seamed to the body to form a base, and at the opposite end is necked inwardly to form a shoulder. A portion of the can body extends away from the free edge of the shoulder into a cylindrical portion which is threaded so as to be closed by a screw closure.

[0003] Alternative proposals for bottle cans use plastic collets to provide a thread for reclosing the can instead of threading the metal neck.

[0004] US-A-2,864,529 upon which the preamble of claim 1 is based describes an overcap for a metal containers having a cone or raised top, the overcap covering a seam which joins the cone to the body of the container. DE 29980137 U describes a plastic component which covers the seam between a neck component and a can body. JP 10 167356 A describes a shoulder cover for fixing a cap which is removeably mounted on a container body.

[0005] Whilst these current proposals are workable in theory, there are, in practice, a number of practical problems. Necking of the container body sufficiently to provide a neck finish for reclosing may involve up to 56 necking stages. Because of its material properties, this is not usually possible if the container is made of steel of conventional thickness (for example 0.08 mm). In order to withstand necking forces, the steel would need to be thicker than is conventional and therefore less economic to use. Furthermore, less metal exposure is acceptable with steel than with aluminium.

[0006] Non-standard sizes of can bodies may need to be used since a standard 355 ml capacity can with a plastic screw threaded neck would be too tall for manufacturing lines.

[0007] This invention seeks to overcome these problems and to provide a bottle can which enables standard tooling to be used, irrespective of the desired neck finish.

[0008] According to the present invention, there is provided a reclosable container comprising a metal can body having a base and a side wall, a metal neck component seamed to a free end of the can body, the neck component comprising a generally frustoconical shoulder portion and a cylindrical portion, the container further comprising a sleeve which fits over the metal neck component and covers the seam between the neck component and can body; characterised in that the sleeve is of plastics material, extends over the cylindrical portion of the neck component, is threaded to allow reclosability of the container and is held in position by a flange or curl (15).

[0009] It should be noted that the term "generally frustoconical" is intended herein to mean both a precise frus-

toconical shape and shapes which reduce the cross-sectional area of the container such as a stepped shoulder portion.

[0010] The can body is typically a standard beverage can body which can be mass-produced using regular beverage can manufacturing lines. Different neck finishes can be offered by a range of neck components and plastic sleeves. The can body may be made from steel or aluminium of thin gauges such as 0.1 mm for aluminium, 0.08 mm for steel. The neck component may be of thicker material and provides barrier properties to prevent, for example, passage of gas which may affect the product in the container.

[0011] According to a preferred aspect of the invention, the sleeve includes a detent for fixing the sleeve onto the seam. This detent provides a seal to prevent water ingress. Ideally the open end of the sleeve is retained by a curl on the neck component. Generally the can body has a small necked-in region at the end to which the neck component is seamed. The sleeve may extend over this region on the can body so as to fit against the can body side wall and resist water ingress.

[0012] The sleeve may be profiled so as to correspond to the shoulder shape on a conventional plastic bottle. In this embodiment the neck component includes a support region between the frustoconical and cylindrical portions. This support region may be a second cylindrical portion of larger diameter than the first cylindrical portion such that the first cylindrical portion supports the threaded part of the plastic sleeve and the second portion supports a part of the sleeve which is profiled to a shoulder shape.

[0013] Preferred embodiments of the invention will now be described, by way of example only, with reference to the drawings, in which:

Figure 1 is a schematic side section of a first embodiment of container according to the invention; and Figure 2 is an enlarged side section of the shoulder and neck region of the container of figure 1.

Figure 1 shows a container comprising a can body 1, neck component 10 and sleeve 20. The can is a typical beverage can body comprising a side wall 2, necked at its upper end 3, and an integral domed base 4. The can body is made of sheet metal, typically steel or aluminium in the range of 0.25 mm to 0.35 mm thick with walls reduced in thickness during manufacture.

[0014] Neck component 10 comprises a metal support having a generally frustoconical part 11 and a cylindrical portion 12. As best shown in figure 2, a second cylindrical portion 13 is joined to the first cylindrical portion by a shoulder 14. The neck component terminates in a flange or, ideally, curl 15 at its upper end which holds the plastic sleeve 20 in position. The sleeve thus also hides the cut edge of the neck component. At its lower end the neck component is fixed by a double seam 16 to the can body 1.

[0015] If the container is closed by a plastics closure having a bore seal, the bore seal will impart further cut edge protection. In this instance the cut edge of curl 15 would be trapped between the sleeve 20 and the bore seal of the closure.

[0016] The sleeve 20 has a curved sheath 23 with a hook-shaped detent 21 which clips onto the seam 16. Annulus 22 provides further location of the sleeve over the seam. The sleeve of figures 1 and 2 is thus fixed in position by the detent 21 and neck component flange 15. In this embodiment, the sleeve 20 has a cylindrical upper portion 24 which is threaded 25. Below thread 25 the upper portion includes a neck support ring 26 for handling purposes.

[0017] For aesthetic reasons the sleeve may be shaped so as to blend into the side wall of the can body. The sleeve may be made of thin plastics so that extra support for the curved shape is provided by shoulder 14 of the neck component.

Claims

1. A reclosable container comprising:

a metal can body (1) having a base (4) and a side wall (2),

a metal neck component (10) seamed to a free end of the can body, the neck component comprising a generally frustoconical shoulder portion (11) and a cylindrical portion (12), and a sleeve (20) which fits over the metal neck component (10) and covers the seam (16) between the neck component (10) and can body (1);

characterised in that the sleeve is of plastics material, extends over the cylindrical portion (12) of the neck component (10), is threaded (25) to allow reclosability of the container and is held in position by a flange or curl (15) at the upper end of the neck component (10).

2. A container according to claim 1, in which the sleeve (20) includes a detent (21) for fixing the sleeve onto the seam (16).

3. A container according to claim 1 or claim 2, in which the neck component (10) includes a support region (14) between the frustoconical and cylindrical portions.

Patentansprüche

1. Wiederverschließbarer Behälter, der aufweist:

einen Metall Dosenkörper (1) mit einer Basis (4) und einer Seitenwand (2);

ein Metallhalsteil (10), das zu einem freien Ende

des Dosenkörpers umgeschlagen ist, wobei das Halsteil einen im Allgemeinen kegelstumpfförmigen Absatzabschnitt (11) und einen zylindrischen Abschnitt (12) aufweist; und

eine Hülse (20), die über das Metallhalsteil (10) passt und den Umschlag (16) zwischen dem Halsteil (10) und dem Dosenkörper (1) bedeckt; **dadurch gekennzeichnet, dass** die Hülse aus Kunststoffmaterial besteht, sich über den zylindrischen Abschnitt (12) des Halsteils (10) erstreckt, mit Gewinde (25) versehen ist, um die Wiederverschließbarkeit des Behälters zu gestatten, und mittels eines Flansches oder einer Bördelung (15) am oberen Ende des Halsteils (10) in Position gehalten wird.

2. Behälter nach Anspruch 1, bei dem die Hülse (20) eine Arretierung (21) für das Befestigen der Hülse am Umschlag (16) umfasst.

3. Behälter nach Anspruch 1 oder Anspruch 2, bei dem das Halsteil (10) einen Stützbereich (14) zwischen dem kegelstumpfförmigen und dem zylindrischen Abschnitt umfasst.

Revendications

1. Récipient refermable, comprenant :

un corps de boîte métallique (1), comportant une base (4) et une paroi latérale (2) ;

un composant de col métallique (10) relié à une extrémité libre du corps de la boîte, le composant de col comprenant une partie d'épaulement généralement en tronc de cône (11) et une partie cylindrique (12) ; et

un manchon (20) ajusté au-dessus du composant de col métallique (10) et recouvrant le pli (16) entre le composant de col (10) et le corps de la boîte (1) ;

caractérisé en ce que le manchon est composé d'un matériau plastique, **en ce qu'**il s'étend au-dessus de la partie cylindrique (12) du composant de col (10), **en ce qu'**il est fileté (25) pour permettre une refermeture du récipient, et **en ce qu'**il est retenu dans sa position par une bride ou une boucle (15) au niveau de l'extrémité supérieure du composant de col (10).

2. Récipient selon la revendication 1, dans lequel le manchon (20) englobe un cliquet (21) pour fixer le manchon sur le pli (16).

3. Récipient selon les revendications 1 ou 2, dans lequel le composant de col (10) englobe une région de support (14) entre les parties en tronc de cône et cylindrique.

Fig.1.

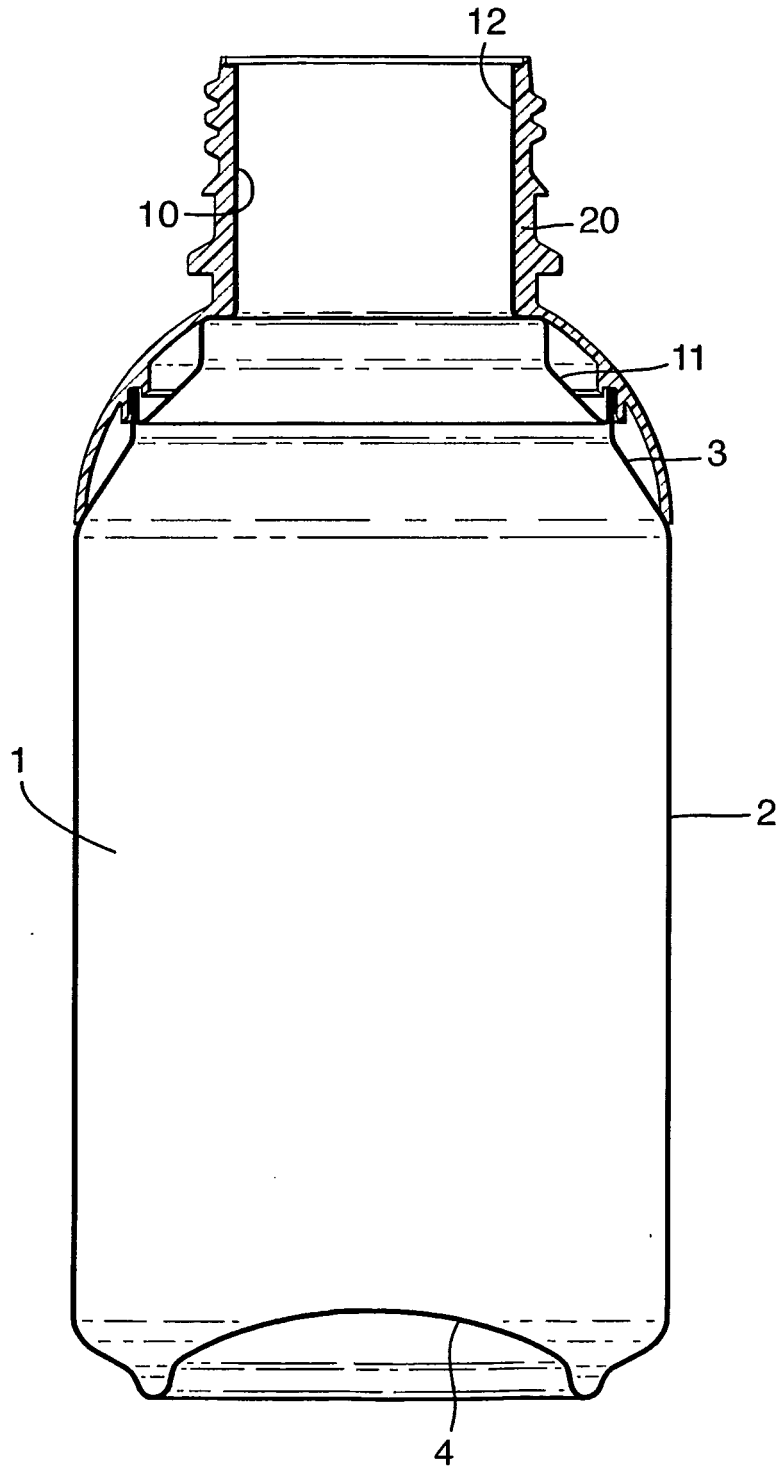
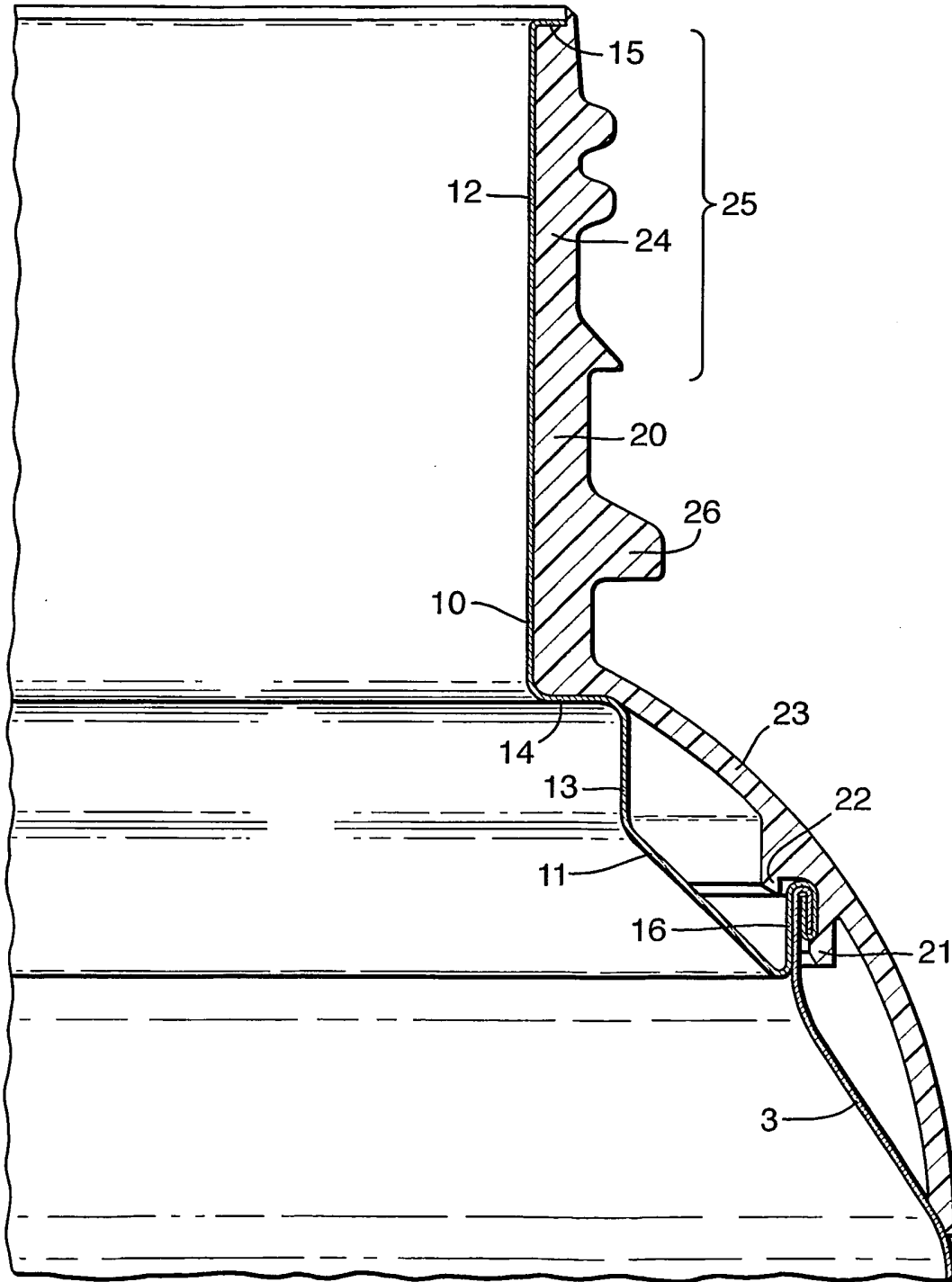

Fig.2.



REFERENCES CITED IN THE DESCRIPTION

This list of references cited by the applicant is for the reader's convenience only. It does not form part of the European patent document. Even though great care has been taken in compiling the references, errors or omissions cannot be excluded and the EPO disclaims all liability in this regard.

Patent documents cited in the description

- JP 2003165539 A [0002]
- US 2864529 A [0004]
- DE 29980137 U [0004]
- JP 10167356 A [0004]