

(12) INTERNATIONAL APPLICATION PUBLISHED UNDER THE PATENT COOPERATION TREATY (PCT)

(19) World Intellectual Property
Organization

International Bureau

(43) International Publication Date
21 December 2017 (21.12.2017)



(10) International Publication Number
WO 2017/218412 A1

(51) International Patent Classification:

B65D 65/46 (2006.01) *C11D 17/04* (2006.01)

(21) International Application Number:

PCT/US2017/037008

(22) International Filing Date:

12 June 2017 (12.06.2017)

(25) Filing Language:

English

(26) Publication Language:

English

(30) Priority Data:

62/349,611 13 June 2016 (13.06.2016) US

(71) Applicant: **MONOSOL, LLC** [US/US]; 707 E. 80th Place, Suite 301, Merrillville, IN 46410 (US).

(72) Inventors: **SOUTER, Philip, Frank**; Procter & Gamble Technical Centres Ltd. Newcastle, Whitley Road Longbenton, Newcastle upon Tyne NE12 9TS (GB). **KEULEERS, Robby Renilde, Francois**; Broekstraat 58, B-2890 Lippele (Sint-Amands) (BE). **LABEQUE, Regine**; Rue de Lombartzyde, 27/7, B-1120 Bruxelles (BE). **COURCHAY, Florence, Catherine**; Rue Emiel Van Elewijck 81, B-1780 Wemmel (BE). **RENMANS, Marc Rene, Bert**; Temselaan 100, B-1853 Strombeek-Bever (BE).

(74) Agent: **MUCZYNSKI, Michael**; Marshall, Gerstein & Borun LLP, 233 S. Wacker Drive, 6300 Willis Tower, Chicago, IL 60606-6357 (US).

(81) Designated States (*unless otherwise indicated, for every kind of national protection available*): AE, AG, AL, AM, AO, AT, AU, AZ, BA, BB, BG, BH, BN, BR, BW, BY, BZ, CA, CH, CL, CN, CO, CR, CU, CZ, DE, DJ, DK, DM, DO, DZ, EC, EE, EG, ES, FI, GB, GD, GE, GH, GM, GT, HN, HR, HU, ID, IL, IN, IR, IS, JO, JP, KE, KG, KH, KN, KP, KR, KW, KZ, LA, LC, LK, LR, LS, LU, LY, MA, MD, ME, MG, MK, MN, MW, MX, MY, MZ, NA, NG, NI, NO, NZ, OM, PA, PE, PG, PH, PL, PT, QA, RO, RS, RU, RW, SA, SC, SD, SE, SG, SK, SL, SM, ST, SV, SY, TH, TJ, TM, TN, TR, TT, TZ, UA, UG, US, UZ, VC, VN, ZA, ZM, ZW.

(84) Designated States (*unless otherwise indicated, for every kind of regional protection available*): ARIPO (BW, GH, GM, KE, LR, LS, MW, MZ, NA, RW, SD, SL, ST, SZ, TZ, UG, ZM, ZW), Eurasian (AM, AZ, BY, KG, KZ, RU, TJ, TM), European (AL, AT, BE, BG, CH, CY, CZ, DE, DK, EE, ES, FI, FR, GB, GR, HR, HU, IE, IS, IT, LT, LU, LV, MC, MK, MT, NL, NO, PL, PT, RO, RS, SE, SI, SK, SM, TR), OAPI (BF, BJ, CF, CG, CI, CM, GA, GN, GQ, GW, KM, ML, MR, NE, SN, TD, TG).

Published:

— with international search report (Art. 21(3))

(54) Title: USE OF A WATER-SOLUBLE UNIT DOSE ARTICLE TO IMPROVE THE USER DOSING EXPERIENCE

(57) Abstract: The present invention relates to the use of water-soluble unit dose article to improve dosing experience.

WO 2017/218412 A1

USE OF A WATER-SOLUBLE UNIT DOSE ARTICLE TO IMPROVE THE USER
DOSING EXPERIENCE

CROSS-REFERENCE TO RELATED APPLICATION

[0001] The benefit under 35 U.S.C. §119(e) of U.S. Provisional Patent Application No. 62/349,611 filed June 13, 2016, is hereby claimed, and the disclosure thereof is hereby incorporated by reference herein.

FIELD

[0002] The present disclosure relates to the use of water-soluble unit dose article to improve the end users dosing experience.

BACKGROUND

[0003] Water-soluble unit dose articles are preferred by users as they are a convenient, efficient and clean way of dosing a composition for use. The water-soluble unit dose form means that the user does not need to measure the dose themselves nor do they suffer from accidental spillage of the unit dose contents, which some users find messy and inconvenient.

[0004] However, such water-soluble unit dose articles can suffer from premature rupture during handling. For example, as the user transfers or otherwise handles the water-soluble unit dose article, e.g. in transfer of a detergent unit dose from a storage receptacle to an automatic washing machine, e.g. the drum of an automatic washing machine, the water-soluble film could tear, or rip, resulting in premature release of the contents onto the hand of the user. This negatively affects the dosing experience as the user will find the operation 'messy' and inconvenient.

[0005] Furthermore, such premature rupture could occur in a storage receptacle, such as a bag or tub, during transport. This again results in a messy and inconvenient dosing/handling experience for the user due to the unit dose articles being contaminated with composition from the ruptured article.

[0006] Therefore, there is a need in the art to improve the user dosing experience.

[0007] It was surprisingly found that the use of a water-soluble unit dose article according to the present invention overcame this technical problem.

SUMMARY

[0008] The present invention discloses a unit dose article comprising at least a first water-soluble film, a second water-soluble film and optionally a composition within the unit dose article, wherein the first water-soluble film and the second water-soluble film are chemically different to one another, and the use thereof in order to improve the user dosing experience; wherein the first water soluble film has a first elongation modulus, the second water soluble film has a second elongation modulus, the first elongation modulus is greater than the second elongation modulus, and the difference between the first elongation modulus and the second elongation modulus is in a range of 0.5 MPa to 10 MPa.

BRIEF DESCRIPTION OF THE DRAWINGS

[0009] The figures herein are illustrative in nature and are not intended to be limiting.

[0010] FIG. 1 shows a schematic illustration of the basic configuration of the unit dose article strength test and seal failure test.

[0011] FIG. 2 shows a side cross-sectional view of a pouch.

[0012] FIG. 3 shows a multi-compartment pouch.

DETAILED DESCRIPTION

[0013] The present disclosure relates to a unit dose article and the use of a unit dose article comprising at least a first water-soluble film, a second water-soluble film and optionally a composition contained within the unit dose article, wherein the first water-soluble film and the second water-soluble film are chemically different to one another, in order to improve the user dosing experience.

[0014] The unit dose article, the first water-soluble film, the second water-soluble film and the optional composition are described in more detail below.

[0015] Preferably, the user dosing experience comprises the user transferring or otherwise handling at least one water-soluble unit dose article, e.g. transferring it from a storage receptacle to another container or location for use. One or more of the water-

soluble unit dose articles may be directly added to bulk water, e.g. for water-conditioning applications, or dispersed on a substrate, e.g. land in the case of agrochemical unit dose articles. The water-soluble unit dose article may be handled by hand. The water-soluble unit dose article may be handled by a machine apparatus, e.g. a conveyor, sorter, or the like.

[0016] The user dosing experience for detergent unit dose article can comprise the user transferring at least one water-soluble unit dose article from a storage receptacle to an automatic washing machine, preferably to the drum of an automatic washing machine. Alternatively, the water-soluble unit dose article may be added to the drawer of an automatic washing machine. The water-soluble unit dose article may be added to the washing machine by hand. The water-soluble unit dose article may be added to the drum by hand. Alternatively it may be dispensed from a storage receptacle into the washing machine, preferably the drum. Those skilled in the art will be aware of relevant storage receptacles.

[0017] A detergent water-soluble unit dose article may be added to the washing machine by hand. A detergent water-soluble unit dose article may be added to the drum by hand. Alternatively it may be dispensed from a storage receptacle into the washing machine, preferably the drum. Those skilled in the art will be aware of relevant storage receptacles.

[0018] Those skilled in the art will be aware of suitable automatic washing machines. Those skilled in the art will also be aware that automatic washing machines comprise a drum and a drawer and will be able to locate said drum or drawer and add both the fabrics and the water-soluble unit dose article thereto accordingly.

[0019] Those skilled in the art will be aware of relevant storage receptacles. Preferably, the storage receptacle is a flexible, preferably resealable, bag, a rigid, preferably recloseable, tub or a mixture thereof, preferably, wherein the storage receptacle comprises a child resistant closure. Those skilled in the art will be aware of suitable child resistant closures.

[0020] Preferably, the improved user dosing experience comprises reduced instances of premature rupture of the water-soluble unit dose articles in handling machinery or the hand of the user, e.g. during transfer such as whilst transferring them from a storage receptacle to a container for use, e.g. a washing drum.

[0021] Without wishing to be bound by theory it was surprisingly found that the use of the specific unit dose article according to the present invention improved the user dosing experience. Such unit dose articles made from the specific choice of two water-soluble films

exhibited reduced instances of premature rupture during or just prior to dosing so providing a less messy and more convenient dosing experience.

Water-soluble unit dose article

[0022] The unit dose article according to the present invention comprises at least a first water-soluble film, a second water-soluble film and optionally a composition contained within the unit dose article, wherein the first water-soluble film and the second water-soluble film are chemically different to one another.

[0023] The water-soluble unit dose article comprises the first water-soluble film and the second water-soluble film shaped such that the unit-dose article comprises at least one internal compartment surrounded by the water-soluble films. The water-soluble films are sealed to one another such to define the internal compartment and such that that the composition does not leak out of the compartment during storage. However, upon contact with sufficient water, e.g. the addition of the water-soluble unit dose article to water, the water-soluble film dissolves and releases the contents of the internal compartment into the water (e.g. wash liquor).

[0024] A preferred method of making a unit dose article is described in more detail below.

[0025] The compartment should be understood as meaning a closed internal space within the unit dose article, e.g. formed by the films, which holds the detergent or other composition. During manufacture, the first water-soluble film according to the present invention may be shaped to comprise an open compartment into which the detergent or other composition is added. The second water-soluble film according to the present invention is then laid over the first film in such an orientation as to close the opening of the compartment. The first and second films are then sealed together along a seal region.

[0026] The unit dose article may comprise more than one compartment, even at least two compartments, or even at least three compartments. The compartments may be arranged in superposed orientation, i.e. one positioned on top of the other. In such an orientation the unit dose article will comprise three films, top, middle and bottom. Preferably, the middle film will correspond to the second water-soluble film according to the present invention and top and bottom films will correspond to the first water-soluble film according to the present invention. Alternatively, the compartments may be positioned in a side-by-side orientation, i.e. one orientated next to the other. The compartments may even be orientated in a 'tyre and rim' arrangement, i.e. a first compartment is positioned next to a second compartment,

but the first compartment at least partially surrounds the second compartment, but does not completely enclose the second compartment. Alternatively one compartment may be completely enclosed within another compartment. In such a multicompartment orientation, the first water-soluble film according to the present invention may be shaped to comprise an open compartment into which the detergent or other composition is added. The second water-soluble film according to the present invention is then laid over the first film in such an orientation as to close the opening of the compartment.

[0027] Wherein the unit dose article comprises at least two compartments, one of the compartments may be smaller than the other compartment. Wherein the unit dose article comprises at least three compartments, two of the compartments may be smaller than the third compartment, and preferably the smaller compartments are superposed on the larger compartment. The superposed compartments preferably are orientated side-by-side.

[0028] In a multi-compartment orientation, the composition according to the present invention may be comprised in at least one of the compartments. It may for example be comprised in just one compartment, or may be comprised in two compartments, or even in three compartments.

[0029] In a multi-compartment orientation, the detergent composition according to the present invention may be comprised in at least one of the compartments. It may for example be comprised in just one compartment, or may be comprised in two compartments, or even in three compartments.

[0030] Each compartment may comprise the same or different compositions. The different compositions could all be in the same form, or they may be in different forms.

[0031] The water-soluble unit dose article may comprise at least two internal compartments, wherein a liquid composition is comprised in at least one of the compartments, preferably wherein the unit dose article comprises at least three compartments, wherein a liquid composition is comprised in at least one of the compartments.

[0032] A water-soluble unit dose detergent article may comprise at least two internal compartments, wherein a liquid laundry detergent composition is comprised in at least one of the compartments, preferably wherein the unit dose article comprises at least three compartments, wherein a detergent composition is comprised in at least one of the compartments.

[0033] First and second water-soluble films

[0034] The water-soluble unit dose article comprises a first water-soluble film and a second water-soluble film and the first water-soluble film and the second water-soluble film are chemically different to one another.

[0035] For the avoidance of doubt, in the context of the present invention ‘chemically different’ herein means where the ‘virgin films’, i.e. films received from the supplier/manufacture and prior to unwinding on a unit dose article making unit, having at least one substance present in at least one of the film compositions that differentiates the first from the second film composition and impacts at least the water capacity, per the test method described herein, rendering this at least one physical film property different between the first and second films. Varying chemical compositions of films due to natural making processes i.e. batch to batch variations are as such not considered chemically different films within the scope of this invention.

[0036] Non limiting examples of chemically differentiating substances include use of different polymer target resins and or content, different plasticizer composition and or content or different surfactant and or content. Water soluble unit dose articles comprising films solely differing in physical properties but having the same substance content, such as films solely differing in film thickness, are considered outside the scope of this invention. Unit dose articles made from films being solely differentiated through the presence versus the absence of a coating layer are also considered outside the scope of the invention.

[0037] The first water soluble film has a first elongation modulus, the second water soluble film has a second elongation modulus, the first elongation modulus is greater than the second elongation modulus, and the difference between the first elongation modulus and the second elongation modulus is from a 0.5 MPa to 10 MPa, preferably from 1 MPa to 8 MPa, more preferably from 2 MPa to 7 MPa.

[0038] By ‘difference’ we herein mean the difference in the value of the first elongation modulus and the value of the second elongation modulus. By ‘elongation modulus’ we herein mean the ability of the film to be elongated when a stress is applied. The method for measuring elongation modulus is described in more detail below.

[0039] Preferably, the first elongation modulus is from 1 MPa to 20 MPa, more preferably from 3MPa to 20 MPa.

[0040] Preferably, the second elongation modulus is from 1 MPa to 15 MPa, more preferably from 3 MPa to 15MPa.

[0041] Preferably, the first water-soluble film has a first tensile strain at break, the second water-soluble film has a second tensile strain at break, wherein the first tensile strain at break is greater than the second tensile strain at break. By 'difference in tensile strain at break' we herein mean the difference in the value of the first tensile strain at break and the second tensile strain at break. The method to determine tensile strain at break is described in more detail below.

[0042] Preferably, the difference between the first tensile strain at break and the second tensile strain at break is from 10% to 1000%, preferably from 100 % to 750%, more preferably from 200% to 500%. By 'difference in tensile strain at break' we herein mean the difference in the value of the first tensile strain at break and the second tensile strain at break.

[0043] Preferably, the first tensile strain at break is from 300% to 1600 %, more preferably from 400% to 1200%, most preferably from 700% to 1200%.

[0044] Preferably, the second tensile strain at break is from 300% to 1200%, more preferably from 500% to 1000%.

[0045] Preferably, the first water-soluble film is thermoformed during manufacture of the unit dose article. By 'thermoforming' we herein mean that the film is heated prior to deformation, e.g., by passing the film under an infrared lamp, the deformation step preferably being enabled by laying the water soluble film over a cavity and applying vacuum or an under pressure inside the cavity under the film. The second water-soluble film may be thermoformed during manufacture of the unit dose article. Alternatively the second water-soluble film may not be thermoformed during manufacture of the unit dose. article. Preferably, the first water-soluble film is thermoformed during manufacture of the unit dose article and the second water-soluble film is not thermoformed during manufacture of the unit dose article.

[0046] The first water-soluble film, the second water-soluble film or a mixture thereof independently may have a thickness before incorporation into the unit dose article of between 40 microns and 100 microns, preferably between 60 microns and 90 microns, more preferably between 70 microns and 80 microns.

[0047] Preferably the difference in thickness before incorporation into the unit dose article between the first water-soluble film and the second water-soluble film is less than 50%,

preferably less than 30%, more preferably less than 20%, even more preferably less than 10%, or the thicknesses may be equal.

[0048] The first water-soluble film and the second water-soluble film according to the invention are preferably single layer films, more preferably manufactured via solution casting.

[0049] The water-soluble film can further have a residual moisture content of at least 4 wt. %, for example in a range of about 4 to about 10 wt. %, as measured by Karl Fischer titration.

[0050] Preferably, the first water-soluble film has a first water capacity and the second water-soluble film has a second water capacity wherein the first water capacity is less than the second water capacity and wherein the difference between the water capacity of the first water soluble film and the second water-soluble film is between 0.01% and 1%, preferably from 0.03% to 0.5%, more preferably from 0.05% to 0.3%. By 'difference' we herein mean the difference in the value of the first water capacity and the value of the second water capacity. By 'water capacity' we herein mean the capacity of the film to absorb water over a fixed period of time at a particular relative humidity, measured as a mass increase of the film being tested. The method for measuring water capacity is described in more detail below.

[0051] Preferably, the first water-soluble film has a water capacity from 1% to 10%, more preferably from 2% to 8%, most preferably from 3 % to 6 % and the second water-soluble film has a water capacity from 1.5% to 12%, preferably from 2.5% to 10%, more preferably from 3.5% to 8%.

[0052] Preferably, the first water soluble film comprises a first water soluble resin and the second water soluble film comprises a second water soluble resin. Preferably, the first water soluble resin comprises at least one polyvinyl alcohol homopolymer or at least one polyvinylalcohol copolymer or a blend thereof and the second water soluble resin comprises at least one polyvinyl alcohol homopolymer or at least one polyvinylalcohol copolymer or a blend thereof.

[0053] The first water soluble resin may comprise a blend of a polyvinyl alcohol homopolymer and a polyvinyl alcohol copolymer comprising an anionic monomer unit, optionally wherein the blend comprises from 0% to 70% by weight of the first water soluble resin of the polyvinyl alcohol copolymer comprising an anionic monomer unit and from 30% to about 100% by weight of the first water soluble resin of the polyvinyl alcohol homopolymer. The blend can comprise from 10% to 70%, or from 15% to about 65%, or

from 20% to 50%, or from 30% to 40% of the polyvinyl alcohol copolymer comprising an anionic monomer unit, based on the total weight of the first water soluble resin. In another type of embodiment, the blend comprises 65 wt.% or greater of an anionic polyvinyl alcohol copolymer, or greater than 65 wt.% of an anionic polyvinyl alcohol copolymer.

[0054] Polyvinyl alcohol homopolymer means polyvinyl alcohol comprising polyvinyl alcohol units and optionally but preferably polyvinyl acetate units. Polyvinyl alcohol copolymer means a polymer comprising polyvinyl alcohol units, optionally but preferably polyvinyl acetate units and anionically modified polyvinyl alcohol units.

[0055] The second water soluble resin may comprise a blend of a polyvinyl alcohol homopolymer and a polyvinyl alcohol copolymer comprising an anionic monomer unit, optionally wherein the blend comprises from 0% to 70% of the polyvinyl alcohol copolymer comprising an anionic monomer unit and from 30% to 100% of the polyvinyl alcohol homopolymer, based on the total weight of the second water soluble resin in the film. The blend can comprise from 10% to 70%, or from 15% to 65%, or from 20% to 50%, or from 30% to 40% of the polyvinyl alcohol copolymer comprising an anionic monomer unit, based on the total weight of the second water soluble resin in the film. In another type of embodiment, the blend comprises 65 wt.% or greater of an anionic polyvinyl alcohol copolymer, or greater than 65 wt.% of an anionic polyvinyl alcohol copolymer.

[0056] The anionic monomer unit present in the polyvinyl alcohol copolymer of the first resin, present in the polyvinyl alcohol copolymer of the second resin, or a mixture thereof may independently be selected from the group consisting of anionic monomers derived from vinyl acetic acid, alkyl acrylates, maleic acid, monoalkyl maleate, dialkyl maleate, monomethyl maleate, dimethyl maleate, maleic anhydride, fumaric acid, monoalkyl fumarate, dialkyl fumarate, monomethyl fumarate, dimethyl fumarate, fumaric anhydride, itaconic acid, monomethyl itaconate, dimethyl itaconate, itaconic anhydride, citraconic acid, monoalkyl citraconate, dialkyl citraconate, citraconic anhydride, mesaconic acid, monoalkyl mesaconate, dialkyl mesaconate, mesaconic anhydride, glutaconic acid, monoalkyl glutaconate, dialkyl glutaconate, glutaconic anhydride, vinyl sulfonic acid, alkyl sulfonic acid, ethylene sulfonic acid, 2-acrylamido-1-methyl propane sulfonic acid, 2-acrylamide-2-methylpropanesulfonic acid, 2-methylacrylamido-2-methylpropanesulfonic acid, 2-sulfoethyl acrylate, alkali metal salts thereof, esters thereof, and combinations thereof; preferably, wherein the anionic monomer unit is selected from the group consisting of 15 anionic monomers derived from maleic acid, monoalkyl maleate, dialkyl maleate,

maleic anhydride, alkali metal salts thereof, esters thereof, and combinations thereof; more preferably wherein the anionic monomer unit is selected from the group consisting of anionic monomers derived from maleic acid, monomethyl maleate, dimethyl maleate, maleic anyhydride, alkali metal salts thereof, esters thereof, and combinations thereof.

[0057] Preferably, the first and second polyvinyl alcohol copolymers independently comprise from 1 mol% to 8 mol% more preferably from 2 mol% to 5 mol%, most preferably from 3 mol% to 4 mol% of the anionic monomer unit with respect to total polyvinyl alcohol copolymer present.

[0058] Preferably, the first polyvinyl alcohol homopolymer and second polyvinyl alcohol homopolymer and the first polyvinyl alcohol copolymer and second polyvinyl alcohol copolymer independently have a degree of hydrolysis of from 80% to 99% preferably from 85% to 95% more preferably from 86% and 93%.

[0059] Preferably, the first polyvinyl alcohol homopolymers and second polyvinyl alcohol homopolymer and first polyvinyl alcohol copolymer and second polyvinyl alcohol copolymer independently have a 4% solution viscosity in demineralized water at 25 °C in a range of 4 cP to 40cP, preferably of 10cP to 30 cP, more preferably of 12 cP to 25 cP.

[0060] Preferably, the first water-soluble film and the second water-soluble film independently have a water soluble resin content of between 30% and 90%, more preferably between 40% and 80%, even more preferably between 50% and 75%, most preferably between 60% and 70% by weight of the film.

[0061] Other water soluble polymers for use in addition to the first polyvinyl alcohol homopolymers and second polyvinyl alcohol homopolymer and first polyvinyl alcohol copolymer and second polyvinyl alcohol copolymer can include, but are not limited to a vinyl alcohol-vinyl acetate copolymer, sometimes referred to as a PVOH homopolymer, polyacrylates, water-soluble acrylate copolymers, polyvinyl pyrrolidone, polyethyleneimine, pullulan, water-soluble natural polymers including, but not limited to, guar gum, gum Acacia, xanthan gum, carrageenan, and starch, water-soluble polymer derivatives including, but not limited to, modified starches, ethoxylated starch, hydroxyethylated starch and hydroxypropylated starch, copolymers of the forgoing and combinations of any of the foregoing. Yet other water-soluble polymers can include polyalkylene oxides, polyacrylamides, polyacrylic acids and salts thereof, celluloses, cellulose ethers, cellulose

esters, cellulose amides, polyvinyl acetates, polycarboxylic acids and salts thereof, polyaminoacids, polyamides, gelatines, methylcelluloses, carboxymethylcelluloses and salts thereof, dextrans, ethylcelluloses, hydroxyethyl celluloses, hydroxypropyl methylcelluloses, maltodextrins, polymethacrylates, and combinations of any of the foregoing. Such water-soluble polymers, whether PVOH or otherwise are commercially available from a variety of sources.

[0062] Preferably, the water-soluble unit dose article exhibits a dissolution profile, according to the unit dose article dose article machine wash dissolution test method described below of less than 6.2 preferably less than 6 more preferably less than 5.8.

[0063] The first and or second film may independently be opaque, transparent or translucent. The first and or second film may independently comprise a printed area. The printed area may cover between 10 and 80% of the surface of the film; or between 10 and 80% of the surface of the film that is in contact with the internal space of the compartment; or between 10 and 80% of the surface of the film and between 10 and 80% of the surface of the compartment.

[0064] The area of print may cover an uninterrupted portion of the film or it may cover parts thereof, i.e. comprise smaller areas of print, the sum of which represents between 10 and 80% of the surface of the film or the surface of the film in contact with the internal space of the compartment or both.

[0065] The area of print may comprise inks, pigments, dyes, blueing agents or mixtures thereof. The area of print may be opaque, translucent or transparent. The area of print may comprise a single colour or maybe comprise multiple colours, even three colours. The area of print may comprise white, black, blue, red colours, or a mixture thereof. The print may be present as a layer on the surface of the film or may at least partially penetrate into the film. The film will comprise a first side and a second side. The area of print may be present on either side of the film, or be present on both sides of the film. Alternatively, the area of print may be at least partially comprised within the film itself.

[0066] The area of print may be achieved using standard techniques, such as flexographic printing or inkjet printing. Preferably, the area of print is achieved via flexographic printing, in which a film is printed, then moulded into the shape of an open compartment. This compartment is then filled with a detergent or non-detergent composition and a second film

placed over the compartment and sealed to the first film. The area of print may be on either or both sides of the film.

[0067] Alternatively, an ink or pigment may be added during the manufacture of the film such that all or at least part of the film is coloured.

[0068] The first and or second film may independently comprise an aversive agent, for example a bittering agent. Suitable bittering agents include, but are not limited to, naringin, sucrose octaacetate, quinine hydrochloride, denatonium benzoate, or mixtures thereof. Any suitable level of aversive agent may be used in the film. Suitable levels include, but are not limited to, 1 to 5000ppm, or even 100 to 2500ppm, or even 250 to 2000ppm.

[0069] The first and or second film may also comprise other secondary ingredients typically known by a skilled person in the art such as, but not limited to, plasticizers, plasticizer compatibilizers, surfactants, lubricants, release agents, fillers, extenders, cross-linking agents, antiblocking agents, antioxidants, detackifying agents, antifoams, nanoparticles such as layered silicate-type nanoclays (e.g., sodium montmorillonite), bleaching agents (e.g., sodium metabisulfite, sodium bisulfite or others), aversive agents such as bitterants (e.g., denatonium salts such as denatonium benzoate, denatonium saccharide, and denatonium chloride; sucrose octaacetate; quinine; flavonoids such as quercetin and naringin; and quassinoids such as quassin and brucine) and pungents (e.g., capsaicin, piperine, allyl isothiocyanate, and resiniferatoxin), and other functional ingredients, in amounts suitable for their intended purposes. Embodiments including plasticizers are preferred. The amount of such agents can be up to about 50 wt. %, 20 wt. %, 15 wt. %, 10 wt. %, 5 wt. %, 4 wt. % and/or at least 0.01 wt. %, 0.1 wt. %, 1 wt. %, or 5 wt. %, individually or collectively.

[0070] The plasticizer can include, but is not limited to, glycerin, diglycerin, sorbitol, ethylene glycol, diethylene glycol, triethylene glycol, dipropylene glycol, tetraethylene glycol, propylene glycol, polyethylene glycols up to 400 MW, neopentyl glycol, trimethylolpropane, polyether polyols, sorbitol, 2-methyl-1,3-propanediol (MPDiol®), ethanolamines, and a mixture thereof. A preferred plasticizer is glycerin, sorbitol, triethyleneglycol, propylene glycol, dipropylene glycol, 2-methyl-1,3-propanediol, trimethylolpropane, or a combination thereof. The total amount of the plasticizer can be in a range of about 10 wt. % to about 45 wt. %, or about 15 wt. % to about 35 wt. %, or about 20 wt. % to about 30 wt. %, or about 20 wt.% to about 45 wt.%, for example about 25 wt. %,

based on total film weight. In embodiments, the amount of plasticizer in the water-soluble film is expressed in parts per 100 parts total water soluble polymer (PHR) in the water-soluble film and is present at least 30 PHR, or at least 35 PHR, for example. The total amount of plasticizer can be up to 40 PHR or 45 PHR or 50 PHR, for example. The total amount of plasticizer can be in a range of 30-50 PHR, about 32.5 PHR to about 42.5 PHR, or 35-45 PHR, or 35-40 PHR, or greater than 30 PHR and less than 45 PHR, or 40 PHR to 50 PHR, for example. The total amount of plasticizer can be 34 or 37.5 PHR.

[0071] Surfactants for use in water-soluble films are well known in the art. Optionally, surfactants are included to aid in the dispersion of the resin solution upon casting. Suitable surfactants can include the nonionic, cationic, anionic and zwitterionic classes. Suitable surfactants include, but are not limited to, polyoxyethylenated polyoxypropylene glycols, alcohol ethoxylates, alkylphenol ethoxylates, tertiary acetylenic glycols and alkanolamides (nonionics), polyoxyethylenated amines, quaternary ammonium salts and quaternized polyoxyethylenated amines (cationics), and amine oxides, N-alkylbetaines and sulfobetaines (zwitterionics). Other suitable surfactants include dioctyl sodium sulfosuccinate, lactylated fatty acid esters of glycerin and propylene glycol, lactic esters of fatty acids, sodium alkyl sulfates, polysorbate 20, polysorbate 60, polysorbate 65, polysorbate 80, lecithin, acetylated fatty acid esters of glycerin and propylene glycol, and acetylated esters of fatty acids, and combinations thereof. In embodiments, the surfactant is selected from the group consisting of polyoxyethylenated polyoxypropylene glycols, alcohol ethoxylates, alkylphenol ethoxylates, tertiary acetylenic glycols and alkanolamides, polyoxyethylenated amines, quaternary ammonium salts and quaternized polyoxyethylenated amines, and amine oxides, N-alkylbetaines, sulfobetaines, and combinations thereof.

[0072] In various embodiments, the amount of surfactant in the water-soluble film is in a range of about 0.1 wt % to about 8.0 wt %, or about 1.0 wt % to about 7.0 wt %, or about 3 wt% to about 7 wt%, or about 5 wt% to about 7 wt%.. In embodiments, the amount of surfactant in the water-soluble film is expressed in parts per 100 parts total water soluble polymer (phr) in the water-soluble film and is present in a range of about 0.5 phr to about 12 phr, about 1.0 phr to about 11.0 phr, about 3.0 phr to about 10.5 phr, or about 1.0 phr to about 2.0 phr.

[0073] Suitable lubricants/release agents can include, but are not limited to, fatty acids and their salts, fatty alcohols, fatty esters, fatty amines, fatty amine acetates and fatty amides. Preferred lubricants/release agents are fatty acids, fatty acid salts, and fatty amine acetates. In

one type of embodiment, the amount of lubricant/release agent in the water-soluble film is in a range of about 0.02 wt % to about 1.5 wt %, optionally about 0.1 wt % to about 1 wt %.

[0074] Suitable fillers/extenders/antiblocking agents/detackifying agents include, but are not limited to, starches, modified starches, crosslinked polyvinylpyrrolidone, crosslinked cellulose, microcrystalline cellulose, silica, metallic oxides, calcium carbonate, talc, mica, stearic acid and metal salts thereof, for example, magnesium stearate. Preferred materials are starches, modified starches and silica. In one type of embodiment, the amount of filler/extender/antiblocking agent/detackifying agent in the water soluble film can be in a range of about 1 wt.% to about 6 wt.%, or about 1 wt.% to about 4 wt.%, or about 2 wt.% to about 4 wt.%, or about 1 phr to about 6 phr, or about 1 phr to about 4 phr, or about 2 phr to about 4 phr, for example.

[0075] An anti-block agent (e.g. SiO₂ and/or stearic acid)) can be present in the film in an amount of at least 0.1 PHR, or at least 0.5 PHR, or at least 1 PHR, or in a range of about 0.1 to 5.0 PHR, or about 0.1 to about 3.0 PHR, or about 0.4 to 1.0 PHR, or about 0.5 to about 0.9 PHR, or about 0.5 to about 2 PHR, or about 0.5 to about 1.5 PHR, or 0.1 to 1.2 PHR, or 0.1 to 4 PHR, for example 0.5 PHR, 0.6 PHR, 0.7 PHR, 0.8 PHR, or 0.9 PHR.

[0076] If the anti-block agent is an SiO₂ particle, a suitable median particle size for the anti-block agent includes a median size in a range of about 3 or about 4 microns to about 11 microns, or about 4 to about 8 microns, or about 5 to about 6 microns, for example 5, 6, 7, 8, or 8 microns. A suitable SiO₂ is an untreated synthetic amorphous silica designed for use in aqueous systems.

[0077] Detergent composition

[0078] The detergent composition may be in the form of free flowing powder, a liquid, a compacted solid, a gel or a mixture thereof.

[0079] The detergent composition may be in the form of a free flowing powder. Such a free flowing powder may have an average particle size diameter of between 100 microns and 1500 microns, preferably between 100 microns and 1000 microns, more preferably between 100 microns and 750 microns. Those skilled in the art will be aware of standard techniques to measure particle size. The detergent composition may be a free flowing laundry detergent composition.

[0080] The detergent composition may be a liquid. In relation to the liquid detergent composition of the present invention, the term 'liquid' encompasses forms such as

dispersions, gels, pastes and the like. The liquid composition may also include gases in suitably subdivided form. However, the liquid composition excludes forms which are non-liquid overall, such as tablets or granules.

[0081] The detergent composition may be a liquid laundry detergent composition. The term 'liquid laundry detergent composition' refers to any laundry detergent composition comprising a 20 liquid capable of wetting and treating fabric e.g., cleaning clothing in a domestic washing machine.

[0082] The laundry detergent composition is used during the main wash process but may also be used as pre-treatment or soaking compositions.

[0083] Laundry detergent compositions include fabric detergents, fabric softeners, 2-in-1 detergent and softening, pre-treatment compositions and the like.

[0084] The laundry detergent composition may comprise an ingredient selected from bleach, bleach catalyst, dye, hueing dye, brightener, cleaning polymers including alkoxyated polyamines and polyethyleneimines, soil release polymer, surfactant, solvent, dye transfer inhibitors, chelant, builder, enzyme, perfume, encapsulated perfume, polycarboxylates, rheology modifiers, structurant, hydrotropes, pigments and dyes, opacifiers, preservatives, anti-oxidants, processing aids, conditioning polymers including cationic polymers, antibacterial agents, pH trimming agents such as hydroxides and alkanolamines, suds suppressors, and mixtures thereof.

[0085] Surfactants can be selected from anionic, cationic, zwitterionic, non-ionic, amphoteric or mixtures thereof. Preferably, the fabric care composition comprises anionic, non-ionic or mixtures thereof.

[0086] The anionic surfactant may be selected from linear alkyl benzene sulfonate, alkyl ethoxylate sulphate and combinations thereof.

[0087] Suitable anionic surfactants useful herein can comprise any of the conventional anionic surfactant types typically used in liquid detergent products. These include the alkyl benzene sulfonic acids and their salts as well as alkoxyated or non-alkoxyated alkyl sulfate materials. The non-ionic surfactant may be selected from fatty alcohol alkoxyate, an oxo-10 synthesised fatty alcohol alkoxyate, Guerbet alcohol alkoxyates, alkyl phenol alcohol alkoxyates or a mixture thereof. Suitable nonionic surfactants for use herein include the alcohol alkoxyate nonionic surfactants. Alcohol alkoxyates are materials which correspond to the general

formula: $R^1(C_mH_{2m}O)_nOH$ wherein R^1 is a C_8-C_{16} alkyl group, m is from 2 to 4, and n ranges from about 2 to 12. In one aspect, R^1 is an alkyl group, which may be primary or secondary, that comprises from about 9 to 15 carbon atoms, or from about 10 to 14 carbon atoms.

[0088] In one aspect, the alkoxyated fatty alcohols will also be ethoxylated materials that contain on average from about 2 to 12 ethylene oxide moieties per molecule, or from about 3 to 10 ethylene oxide moieties per molecule.

[0089] The shading dyes employed in the present laundry detergent compositions may comprise polymeric or non-polymeric dyes, pigments, or mixtures thereof. Preferably the shading dye comprises a polymeric dye, comprising a chromophore constituent and a polymeric constituent. The chromophore constituent is characterized in that it absorbs light in the wavelength range of blue, red, violet, purple, or combinations thereof upon exposure to light. In one aspect, the chromophore constituent exhibits an absorbance spectrum maximum from about 520 nanometers to about 640 nanometers in water and/or methanol, and in another aspect, from about 560 nanometers to about 610 nanometers in water and/or methanol.

[0090] Although any suitable chromophore may be used, the dye chromophore is preferably selected from benzodifuranes, methine, triphenylmethanes, naphthalimides, pyrazole, naphthoquinone, anthraquinone, azo, oxazine, azine, xanthene, triphenodioxazine and phthalocyanine dye chromophores. Mono and di-azo dye chromophores are preferred.

[0091] The dye may be introduced into the detergent composition in the form of the unpurified mixture that is the direct result of an organic synthesis route. In addition to the dye polymer therefore, there may also be present minor amounts of un-reacted starting materials, products of side reactions and mixtures of the dye polymers comprising different chain lengths of the repeating units, as would be expected to result from any polymerisation step.

[0092] The laundry detergent compositions can comprise one or more detergent enzymes which provide cleaning performance and/or fabric care benefits. Examples of suitable enzymes include, but are not limited to, hemicellulases, peroxidases, proteases, cellulases, xylanases, lipases, phospholipases, esterases, cutinases, pectinases, keratanases, reductases, oxidases, phenoloxidases, lipoxygenases, ligninases, pullulanases, tannases, pentosanases, malanases, β -glucanases, arabinosidases, hyaluronidase, chondroitinase, laccase, and

amylases, or mixtures thereof. A typical combination is a cocktail of conventional applicable enzymes like protease, lipase, cutinase and/or cellulase in conjunction with amylase.

[0093] The laundry detergent compositions of the present invention may comprise one or more bleaching agents. Suitable bleaching agents other than bleaching catalysts include photobleaches, bleach activators, hydrogen peroxide, sources of hydrogen peroxide, pre-formed peracids and mixtures thereof.

[0094] The detergent composition may comprise a brightener. Suitable brighteners are stilbenes, such as brightener 15. Other suitable brighteners are hydrophobic brighteners, and brightener 49. The brightener may be in micronized particulate form, having a weight average particle size in the range of from 3 to 30 micrometers, or from 3 micrometers to 20 micrometers, or from 3 to 10 micrometers. The brightener can be alpha or beta crystalline form.

[0095] The detergent compositions herein may also optionally contain one or more copper, iron and/or manganese chelating agents. The chelant may comprise 1-hydroxyethanediphosphonic acid (HEDP) and salts thereof; N,N-dicarboxymethyl-2-aminopentane-1,5-dioic acid and salts thereof; 2-phosphonobutane-1,2,4-tricarboxylic acid and salts thereof; and any combination thereof.

[0096] The compositions of the present invention may also include one or more dye transfer inhibiting agents. Suitable polymeric dye transfer inhibiting agents include, but are not limited to, polyvinylpyrrolidone polymers, polyamine N-oxide polymers, copolymers of N-vinylpyrrolidone and N-vinylimidazole, polyvinylloxazolidones and polyvinylimidazoles or mixtures thereof.

[0097] The laundry detergent composition may comprise one or more polymers. Suitable polymers include carboxylate polymers, polyethylene glycol polymers, polyester soil release polymers such as terephthalate polymers, amine polymers, cellulosic polymers, dye transfer inhibition polymers, dye lock polymers such as a condensation oligomer produced by condensation of imidazole and epichlorhydrin, optionally in ratio of 1:4:1, hexamethylenediamine derivative polymers, and any combination thereof.

[0098] Other suitable cellulosic polymers may have a degree of substitution (DS) of from 0.01 to 0.99 and a degree of blockiness (DB) such that either $DS+DB$ is of at least 1.00 or $DB+2DS-DS^2$ is at least 1.20. The substituted cellulosic polymer can have a degree of substitution (DS) of at least 0.55. The substituted cellulosic polymer can have a degree of

blockiness (DB) of at least 0.35. The substituted cellulosic polymer can have a DS + DB, of from 1.05 to 2.00. A suitable substituted cellulosic polymer is carboxymethylcellulose.

[0099] Another suitable cellulosic polymer is cationically modified hydroxyethyl cellulose. Suitable perfumes include perfume microcapsules, polymer assisted perfume delivery systems including Schiff base perfume/polymer complexes, starch-encapsulated perfume accords, perfume-loaded zeolites, blooming perfume accords, and any combination thereof. A suitable perfume microcapsule is melamine formaldehyde based, typically comprising perfume that is encapsulated by a shell comprising melamine formaldehyde. It may be highly suitable for such perfume microcapsules to comprise cationic and/or cationic precursor material in the shell, such as polyvinyl formamide (PVF) and/or cationically modified hydroxyethyl cellulose (catHEC).

[0100] Suitable suds suppressors include silicone and/or fatty acid such as stearic acid.

[0101] The laundry detergent composition maybe coloured. The colour of the liquid laundry detergent composition may be the same or different to any printed area on the film of the article. Each compartment of the unit dose article may have a different colour. Preferably, the liquid laundry detergent composition comprises a non-substantive dye having an average degree of alkoxylation of at least 16.

[0102] Other compositions

[0103] The composition for use inside the unit dose article may be a non-detergent composition and/or a non-household care composition. A fabric or household care composition includes fabric treatments, hard surfaces, air care, car care, dishwashing, fabric conditioning and softening, laundry detergency, laundry and rinse additive and/or care, hard surface cleaning and/or treatment, and other cleaning for consumer or institutional use. Non-household care compositions are for other uses. For example, a non-household care composition can be selected from agricultural compositions, aviation compositions, food and nutritive compositions, industrial compositions, livestock compositions, marine compositions, medical compositions, mercantile compositions, military and quasi-military compositions, office compositions, and recreational and park compositions, pet compositions, water-treatment compositions, including cleaning and detergent compositions applicable to any such use while excluding fabric and household care compositions.

[0104] It is contemplated that one type of embodiment will include an article as described herein with a sealed compartment containing a fabric care or household care composition, a film including a blend of a polyvinyl alcohol homopolymer and an anionic polyvinyl alcohol copolymer, and both the first water soluble film and the second water soluble film include blends include 65 wt.% or greater of an anionic polyvinyl alcohol copolymer.

[0105] It is contemplated that another type of embodiment will include an article as described herein with a sealed compartment containing a fabric care or household care composition, a film including a blend of at least two anionic polyvinyl alcohol copolymers, and both then first water soluble film and the second water soluble film include blends of at least two anionic polyvinyl alcohol copolymers.

[0106] In one type of embodiment, the composition can include an agrochemical, e.g. one or more insecticides, fungicides, herbicides, pesticides, miticides, repellants, attractants, defoliants, plant growth regulators, fertilizers, bactericides, micronutrients, and trace elements. Suitable agrochemicals and secondary agents are described in U.S. Patent Nos. 6,204,223 and 4,681,228 and EP 0989803 A1. For example, suitable herbicides include paraquat salts (for example paraquat dichloride or paraquat bis(methylsulphate), diquat salts (for example diquat dibromide or diquat alginate), and glyphosate or a salt or ester thereof (such as glyphosate isopropylammonium, glyphosate sesquisodium or glyphosate trimesium, also known as sulfosate). Incompatible pairs of crop protection chemicals can be used in separate chambers, for example as described in U.S. Patent No. 5,558,228. Incompatible pairs of crop protection chemicals that can be used include, for example, bensulfuron methyl and molinate; 2,4-D and thifensulfuron methyl; 2,4-D and methyl 2-[[[N-(4-methoxy-6-methyl-1,3,5-triazine-2-yl)-N-methylamino]carbonyl]amino]-sulfonyl]benzoate; 2,4-D and metsulfuron methyl; maneb or mancozeb and benomyl; glyphosate and metsulfuron methyl; tralomethrin and any organophosphate such as monocrotophos or dimethoate; bromoxynil and N-[[4,6-dimethoxypyrimidine-2-yl)-amino]carbonyl]-3-(ethylsulfonyl)-2-pyridine - sulfonamide; bromoxynil and methyl 2-[[[(4-methyl-6-methoxy)-1,3,5-triazin-2-yl)amino]carbonyl]amino]sulfonyl]-benzoate; bromoxynil and methyl 2-[[[N-(4-methoxy-6-methyl-1,3,5-triazin-2-yl)-N-methylamino]carbonyl]amino]-sulfonyl]benzoate. In another, related, type of embodiment, the composition can include one or more seeds, optionally together with soil, and further optionally together with one or more additional components selected from mulch, sand, peat moss, water jelly crystals, and fertilizers, e.g. including types of embodiments described in U.S. Patent No. 8,333,033.

[0107] In another type of embodiment, the composition is a water-treatment agent. Such agents include aggressive oxidizing chemicals, e.g. as described in U.S. Patent Application Publication No. 2014/0110301 and U.S. Patent No. 8,728,593. For example, sanitizing agents can include hypochlorite salts such as sodium hypochlorite, calcium hypochlorite, and lithium hypochlorite; chlorinated isocyanurates such as dichloroisocyanuric acid (also referred to as "dichlor" or dichloro-s-triazinetriene, 1,3-dichloro-1,3,5-triazinane-2,4,6-trione) and trichloroisocyanuric acid (also referred to as "trichlor" or 1,3,5-trichloro-1,3,5-triazinane-2,4,6-trione). Salts and hydrates of the sanitizing compounds are also contemplated. For example, dichloroisocyanuric acid may be provided as sodium dichloroisocyanurate, sodium dichloroisocyanurate acid dihydrate, among others. Bromine containing sanitizing agents may also be suitable for use in unit dose packaging applications, such as 1,3-dibromo-5,5-dimethylhydantoin (DBDMH), 2,2-dibromo-3-nitropropionamide (DBNPA), dibromocycano acetic acid amide, 1-bromo-3-chloro-5,5-dimethylhydantoin; and 2-bromo-2-nitro-1,3-propanediol, among others. The oxidizing agent can be one described in U.S. Patent No. 7,476,325, e.g. potassium hydrogen peroxydisulfate. The composition can be a pH-adjusting chemical, e.g. as described in U.S. Patent Application Publication No. 2008/0185347, and can include, for example, an acidic component and an alkaline component such that the composition is effervescent when contacted with water, and adjusts the water pH. Suitable ingredients include sodium bicarbonate, sodium bisulfate, potassium hydroxide, sulfamic acid, organic carboxylic acids, sulfonic acids, and potassium dihydrogen phosphate. A buffer blend can include boric acid, sodium carbonate, glycolic acid, and oxone monopersulfate, for example.

[0108] A water-treatment agent can be or can include a flocculant, e.g. as described in U.S. Patent Application Publication No. 2014/0124454. The flocculant can include a polymer flocculant, e.g. polyacrylamide, a polyacrylamide copolymer such as an acrylamide copolymers of diallyldimethylammonium chloride (DADMAC), dimethylaminoethylacrylate (DMAEA), dimethylaminoethylmethacrylate (DMAEM), 3-methylamidopropyltrimethylammonium chloride (MAPTAC) or acrylic acid; a cationic polyacrylamide; an anionic polyacrylamide; a neutral polyacrylamide; a polyamine; polyvinylamine; polyethylene imine; polydimethyldiallylammonium chloride; polyoxyethylene; polyvinyl alcohol; polyvinyl pyrrolidone; polyacrylic acid; polyphosphoric acid; polystyrene sulfonic acid; or any combination thereof. A flocculant can be selected from chitosan acetate, chitosan lactate, chitosan adipate, chitosan glutamate, chitosan

succinate, chitosan malate, chitosan citrate, chitosan fumarate, chitosan hydrochloride, and combinations thereof. The water-treating composition can include a phosphate removing substance, e.g. one or more selected from a zirconium compound, a rare earth lanthanide salt, an aluminum compound, an iron compound, or any combination thereof.

[0109] The composition can be a limescale removing composition, e.g. citric or maleic acid or a sulphate salt thereof, or any mixture thereof, e.g. as described in U.S. Patent Application No. 2006/0172910.

[0110] Various other types of compositions are contemplated for use in the unit dose articles described herein, including particulates, for example down feathers, e.g. as described in US RE29059 E; super absorbent polymers, e.g. as described in U.S. Patent Application Publication Nos. 2004/0144682 and 2006/0173430; pigments and tinters, e.g. as described in U.S. Patent No. 3,580,390 and U.S. Patent Application Publication No. 2011/0054111; brazing flux (e.g. alkali metal fluoroaluminates, alkali metal fluorosilicates and alkali metal fluorozincates), e.g. as described in U.S. Patent No. 8,163,104; food items (e.g., coffee powder or dried soup) as described in U.S. Patent Application Publication No. 2007/0003719; and wound dressings, e.g. as described in U.S. Patent No. 4,466,431.

[0111] At least one compartment of the unit dose article may comprise a solid. If present, the solid may be present at a concentration of at least 5% by weight of the unit dose article.

Method of making a unit dose article

[0112] Those skilled in the art will be aware of processes to make the detergent and non-detergent compositions of the present invention. Those skilled in the art will be aware of standard processes and equipment to make the detergent and other compositions.

[0113] Those skilled in the art will be aware of standard techniques to make the unit dose article according to any aspect of the present invention. Standard forming processes including but not limited to thermoforming and vacuum forming techniques may be used.

[0114] A preferred method of making the water-soluble unit dose article according to the present invention comprises the steps of moulding the first water-soluble film in a mould to form an open cavity, filling the cavity with the detergent or non-detergent composition, laying the second film over the first film to close the cavity, and sealing the first and second films together preferably through solvent sealing, the solvent preferably comprising water, to produce the water-soluble unit dose article.

[0115] All ranges set forth herein include all possible subsets of ranges and any combinations of such subset ranges. By default, ranges are inclusive of the stated endpoints, unless stated otherwise. Where a range of values is provided, it is understood that each intervening value between the upper and lower limit of that range and any other stated or intervening value in that stated range, is encompassed within the disclosure. The upper and lower limits of these smaller ranges may independently be included in the smaller ranges, and are also encompassed within the disclosure, subject to any specifically excluded limit in the stated range. Where the stated range includes one or both of the limits, ranges excluding either or both of those included limits are also contemplated to be part of the disclosure.

[0116] It is expressly contemplated that for any number value described herein, e.g. as a parameter of the subject matter described or part of a range associated with the subject matter described, an alternative which forms part of the description is a functionally equivalent range surrounding the specific numerical value (e.g. for a dimension disclosed as “40 mm” an alternative embodiment contemplated is “about 40 mm”).

Test protocols

Unit dose article machine wash dissolution test method

[0117] This method is designed to assess the relative dissolution properties of laundry water soluble unit dose articles under stressed washing machine conditions. For this method Electrolux

[0118] Programmable Washing machines type W565H , an adjusted EMPA221 load (EMPA221 source : Swisstat - SWISSatest testmaterials, Movenstrasse 12 CH9015 St Gallen, Switzerland) and Digieye picture taking equipment (Digieye by VeriVide) were used.

[0119] The adjusted EMPA221 load was prepared by coloring the load into orange by using commercially available dye solutions for in washing machines dye (Dylon goldfish orange washing machine dye (N° 55)). To color the load any standard household washing machine can be used, employing a standard cotton cycle at 40 °C. 500g of salt and 200g of the Dylon goldfish orange machine dye are added to the drum of the washing machine. The drum was consequently moved to the left and the right until the salt and the dye were not visible anymore. 25 EMPA 221 items (size of 50cm x 50cm, overlapped on the edges to prevent fraying), were consequently evenly distributed over the drum without folding of the items. A standard cotton cycle at 40°C was run at a water hardness of 15ppg. After

completion of the cycle 50g of Ariel Sensitive powder was added into the dispenser and a normal cotton cycle at 40°C was run at a water hardness of 15gpg. After completion of this cycle 2 additional normal cotton cycles at 40°C without any detergent were run at a water hardness of 15gpg, followed by line-drying the items. To note : Brand new EMPA221 items must be desized before coloring them by adding 25 items into a front loading Miele washing machine and running 2 short cotton cycles at 60°C (approximate duration of 1h30) with 50g of Ariel sensitive powder and a water hardness of 15gpg, followed by running 2 more short cotton cycles at 60°C (approximate duration of 1h30) with no detergent and a water hardness of 15gpg, followed by tumble drying.

[0120] The Electrolux W565 programmable washing machines were programmed with 2 programs. The first program was designed to equally wet the load (pre-wet program). The second program (dissolution program) was utilized to simulate 10min of a Western Europe stressed cycle setting, followed by pumping out the water and starting a spin of 3min at 1100rpm.

		Pre-wet program	Dissolution program
Wash	Time	5min	10min
	Motor rotation	49rpm	40rpm
	Water intake	12L	4L
	Heating	No heating	No heating
	Motor action time clockwise	28s	28s
	Motor resting time	12s	12s
	Motor action time Counterclockwise	28s	28s
Drain	Draining time	20s	20s
	Motor rotation	20rpm	49rpm
Extraction	Time	NA	3min
	Motor rotation	NA	1100rpm

[0121] A load consisting of 50 dyed EMPA221 fabrics (ca. 2.45kg) was evenly introduced in the Electrolux W565 washing machine and the pre-wet program was started. After the pre-wet program, 6 water soluble unit dose articles were distributed evenly across the wet load, after which the dissolution program was initiated. At the end of the full program, the wet load was transferred to a grading room (equipped with D65 lighting conditions) to be assessed for

residues by expert graders. Each fabric which had discoloration spots due to remnant detergent or excess PVA, was selected out of the load for image analysis.

[0122] This image analysis was conducted by acquiring pictures of each side of the selected fabrics using the Digi-Eye camera (setting : “d90 Diffuse Light. Shutter time 1/4. Aperture 8”). The fabrics should be put onto a gray or black background to enhance the contrast. After this the image was assessed through image analysis software to calculate the total size of residue detected in the load (pixel count). This tool detects residues by identifying spots that are of a different color than the normal ballast, using delta E thresholding (delta E of 6). For one machine and load a residue score is then calculated by summing the total area of residues present in the load. The logarithmic value of the total residue area is calculated and the average of 4 external replicates, i.e. 4 different washing machine runs, was reported.

Unit dose article strength test method

[0123] This test method describes the practice for determining the unit dose article strength using the Instron Universal Materials Testing instrument (Instron Industrial Products, 825 University Ave., Norwood, MA 02062-2643) with a load cell of maximum 100 kN (kilo Newton). Via compression of a unit dose article, this method determines the overall strength (in Newtons) of the unit dose article by putting pressure on the film and seal regions. Unit dose article strength (in Newtons) is defined as the maximum load a unit dose article can support before it breaks. Unit dose articles opening at the seal area at a pressure lower than 250N are reported as seal failures, and are not taken into account when determining average unit dose article strength.

[0124] The unit dose article strength was measured no sooner than one hour after unit dose article production so that the film/unit dose articles had time to set after converting. The method was performed in a room environment between 30% and 40% relative humidity (RH) and 20% and 23°C. Stored unit dose articles were allowed to re-equilibrate to the testing room environment for one hour prior to testing.

[0125] FIG. 1. shows a schematic illustration of the basic configuration of the unit dose article strength test. To measure unit dose article strength, a unit dose article 510 was enclosed in a plastic de-aerated bag 500 (150 mm by 124 mm with closure, 60 micron thick - e.g. Raja grip RGP6B) to prevent contamination of working environment upon unit dose article rupture. After enclosure in the bag, the unit dose article 510 was centered between two

compression plates 520, 530 of the instrument. The unit dose article 510 was placed in an upright position, so that the width seal dimension 540 (e.g. smallest dimension within a defined rectangular plane just encompassing the seal area, 41mm in actual unit dose articles tested) was between the compression plates (x-direction) such that the stress was applied on the width seal. For the compression, the speed of decreasing the distance between the plates 520 and 530 is set at 60 mm/min. Ten replicates were conducted per test leg, and average unit dose article strength data, excluding seal failures as defined above, are reported.

Tensile Strain Test and e-modulus Test

[0126] A water-soluble film characterized by or to be tested for tensile strain according to the Tensile Strain (TS) Test and e-modulus (elongation modulus or tensile stress) according to the Modulus (MOD) Test was analyzed as follows. The procedure includes the determination of tensile strain and the determination of e-modulus according to ASTM D 882 (“Standard Test Method for Tensile Properties of Thin Plastic Sheeting”). An INSTRON tensile testing apparatus (Model 5544 Tensile Tester or equivalent - Instron Industrial Products, 825 University Ave., Norwood, MA 02062-2643) was used for the collection of film data. A minimum of three test specimens, each cut with reliable cutting tools (e.g. JDC precision sample cutter, Model 1-10, from Thwing Albert Instrument Company, Philadelphia, PA U.S.A.) to ensure dimensional stability and reproducibility, were tested in the machine direction (MD) (where applicable), i.e. water soluble film roll winding / unwinding direction, for each measurement. Water soluble films were pre-conditioned to testing environmental conditions for a minimum of 48h. Tests were conducted in the standard laboratory atmosphere of $23 \pm 2.0^{\circ}\text{C}$ and $35 \pm 5 \%$ relative humidity. For tensile strain or modulus determination, 1”-wide (2.54 cm) samples of a single film sheet having a thickness of 3.0 ± 0.15 mil (or $76.2 \pm 3.8 \mu\text{m}$) are prepared. For e-modulus testing virgin films were tested. For tensile strain testing test films were first pre-immersed in testing detergent according to the protocol described below. The sample was then transferred to the INSTRON tensile testing machine to proceed with testing. The tensile testing machine was prepared according to manufacturer instructions, equipped with a 500 N load cell, and calibrated. The correct grips and faces were fitted (INSTRON grips having model number 2702-032 faces, which are rubber coated and 25 mm wide, or equivalent). The samples were mounted into the tensile testing machine, elongated at a rate of 1N/min, and analyzed to determine the e- modulus

(i.e., slope of the stress-strain curve in the elastic deformation region) and tensile strain at break (i.e., % elongation achieved at the film break, i.e. 100% reflects starting length, 200% reflects a film that has been lengthened 2 times at film break). The average of minimum three test specimens was calculated and reported.

Film pre-immersion protocol

[0127] A film sample measuring 11 cm by 12 cm was prepared of both films intended to be used to form a sealed compartment enclosing a liquid household detergent composition. A total of 750 ml of the household liquid detergent composition intended to be enclosed within a sealed compartment comprising the test films, was required for each test film. The bottom of a clean inert glass recipient was covered with a thin layer of liquid and the film to be tested was spread on the liquid; air bubbles trapped under the film were gently pushed towards the sides. The remaining liquid was then gently poured on top of the film, in such a way that the film was fully immersed into the liquid. The film should remain free of wrinkles and no air bubbles should be in contact with the film. The film stayed in contact with the liquid and was stored under closed vessel conditions for 6 days at 35°C and 1 night at 21°C. A separate glass recipient was used for each test film. The film was then removed from the storage vessel, and the excess liquid was removed from the film. A piece of paper was put on the film which was laid on top of a bench paper, and then the film was wiped dry thoroughly with dry paper. Films were consequently preconditioned to tensile strain environmental testing conditions as described above. When intending enclosing solid household detergent compositions, virgin films were used for tensile strain testing.

Method for measurement of water capacity

[0128] Water capacity was measured with a DVS (Dynamic Vapor Sorption) Instrument. The instrument used was a SPS-DVS (model SPSx-1 μ -High load with permeability kit) from ProUmid. The DVS uses gravimetry for determination of moisture sorption/desorption and is fully automated.

[0129] The accuracy of the system is $\pm 0.6\%$ for the RH (relative humidity) over a range of 0-98% and $\pm 0.3^\circ\text{C}$ at a temperature of 25°C. The temperature can range from +5 to +60 °C. The microbalance in the instrument is capable of resolving 0.1 μg in mass change. 2 replicates of each film are measured and the average water capacity value is reported.

[0130] For the specific conditions of the test, a 6 pan carousel which allows to test 5 films simultaneously (1 pan is used as a reference for the microbalance and needs to remain empty) was used.

[0131] Each pan has an aluminum ring with screws, designed to fix the films. A piece of film was placed onto a pan and after gentle stretching, the ring was placed on top and the film was tightly fixed with the screws and excess film removed. The film covering the pan surface had an 80 mm diameter.

[0132] The temperature was fixed at 20°C. Relative humidity (RH) was set at 35% for 6 hours, and then gradually raised onto 50 % in 5 min. The RH remained at 50 % for 12hours. The total duration of the measurement was 18 hours.

[0133] The cycle time (= time between measuring each pan) was set to 10 min and the DVS records each weight result vs. time and calculates automatically the % Dm (relative mass variation versus starting weight of the film, i.e. 10% reflects a 10% film weight increase versus starting film weight).

[0134] The water capacity (or %Dm gained over 50%RH cycle during the fixed time of 12 hours at 20°C) was calculated by difference of the value %Dm at 50%RH (last value measured at 50%RH) minus %Dm at 35%RH (last value before going up to 50%RH).

EXAMPLES

[0135] The following unit dose articles were prepared and tested for unit dose article strength per the protocol described herein. Comparative unit dose article outside the scope of the invention have been prepared out of a single film type while example unit dose articles according to the invention have been prepared out of two different films, differing in e-modulus according to the invention.

[0136] Multicompartment water soluble unit dose articles with a 41mm x 43mm footprint, cavity depth of 20.1mm and cavity volume of 25ml, were made through thermo/vacuum forming.

[0137] For dual film example unit dose article films A and C were deformed under vacuum while films B and D were used as closing films respectively. A standard detergent composition, as commercially available in the UK in January 2016 in the bottom

compartment of Fairy non-Bio 3-in-1 water soluble unit dose article product was enclosed inside these unit dose articles as a test composition.

[0138] Table 1 below details film compositions used to prepare comparative and example unit dose articles.

Table 1

Starting film thickness = 76 micron	Resin content in film	Blend ratio	Polymer 1 (anionic-PVOH copolymer)				Polymer 2 (PVOH homopolymer)		
			Anionic source	Anionic substitution	dH	4% viscosity	dH	4% viscosity	
Example 1									
Comparative pouch 1 (single film type = B)	Film B	65%	30/70	Monomethyl maleate (carboxylated)	4%	89%	16cps	87%	13cps
Example pouch 1 (dual film type = A+B)	Film A	65%	40/60	Monomethyl maleate (carboxylated)	4%	89%	16cps	87%	24cps
	Film B	65%	30/70	Monomethyl maleate (carboxylated)	4%	89%	16cps	87%	13cps
Example 2									
Comparative pouch 2 (single film type = D)	Film D	65%	30/70	Monomethyl maleate (carboxylated)	4%	89%	16cps	88%	12cps
Example pouch 2 (dual film)	Film C	65%	30/70	Monomethyl maleate (carboxylated)	4%	89%	16cps	88%	17cps

type = C+D)	Film D	65%	30/70	Monomethyl maleate (carboxylated)	4%	89%	16cps	88%	12cps
-------------	--------	-----	-------	-----------------------------------	----	-----	-------	-----	-------

[0139] Table 2 below details physical properties of the respective films used in the examples.

Table 2

	e-modulus	Tensile strain at break	Water capacity
Film A	11.4MPa	1123%	5.058%
Film B	8.25MPa	855%	5.141%
Film C	19.35MPa	906%	4.259%
Film D	14.29MPa	555%	4.406%

[0140] From Table 3 below it is clear that the example unit dose articles 1 and 2 made of 2 films differing in e-modulus according to the scope of the invention provide both good pouch strength, compared to respective comparative examples 1 and 2 made out of a single type film showing an inferior unit dose article strength.

Pouch	Pouch strength (N)
Example 1	
Comparative article 1	427
Article 1	613
Example 2	
Comparative article 2	427
Article 2	544

[0141] Every document cited herein, including any cross referenced or related patent or application, is hereby incorporated herein by reference in its entirety unless expressly excluded or otherwise limited. The citation of any document is not an admission that it is

prior art with respect to any invention disclosed or claimed herein or that it alone, or in any combination with any other reference or references, teaches, suggests or discloses any such invention. Further, to the extent that any meaning or definition of a term in this document conflicts with any meaning or definition of the same term in a document incorporated by reference, the meaning or definition assigned to that term in this document shall govern.

[0142] While particular embodiments of the present invention have been illustrated and described, it would be obvious to those skilled in the art that various other changes and modifications can be made without departing from the spirit and scope of the invention. It is therefore intended to cover in the appended claims all such changes and modifications that are within the scope of this invention.

CLAIMS

What is claimed is:

1. Use of a unit dose article comprising at least a first water-soluble film, a second water-soluble film and optionally a composition contained within the unit dose article, wherein the first water-soluble film and the second water-soluble film are chemically different to one another, in order to improve the user detergent dosing experience; wherein the first water soluble film has a first elongation modulus, the second water soluble film has a second elongation modulus, the first elongation modulus is greater than the second elongation modulus, and the difference between the first elongation modulus and the second elongation modulus is from a 0.5 MPa to 10 MPa; provided that when the composition is a fabric care or household care composition and a film comprises a blend of a polyvinyl alcohol homopolymer resin and an anionic polyvinyl alcohol copolymer resin, then both then first water soluble film and the second water soluble film comprise blends that include 65 wt.% or greater of an anionic polyvinyl alcohol copolymer resin; and provided that when the composition is a fabric care or household care composition and a film comprises a blend of at least two anionic polyvinyl alcohol copolymer resins, then both then first water soluble film and the second water soluble film comprise blends of at least two anionic polyvinyl alcohol copolymer resins.
2. The use according to claim 1, wherein the difference between the first elongation modulus and the second elongation modulus is from 1 MPa to 8 MPa, preferably from 2 MPa to 7 MPa.
3. The use according to any one of the preceding claims, wherein the first elongation modulus is from 1 MPa to 20 MPa, preferably from 3MPa to 20 MPa.
4. The use according to any one of the preceding claims, wherein the second elongation modulus is from 1 MPa to 15 MPa, preferably from 3 MPa to 15MPa.
5. The use according to any one of the preceding claims, wherein the first water-soluble film has a first tensile strain at break, the second water-soluble film has a second tensile strain at break, wherein the first tensile strain at break is greater than the second tensile

strain at break and the difference between the first tensile strain at break and the second tensile strain at break is from 10% to 1000%, preferably from 100 % to 750%, more preferably from 200% to 500%; and

wherein the first tensile strain at break is from 300% to 1600 %, preferably from 400% to 1200%, more preferably from 700% to 1200%; and

wherein the second tensile strain at break is from 300% to 1200%, preferably from 500% to 1000%.

6. The use according to any one of the preceding claims wherein the first water soluble film comprises a first water soluble resin and the second water soluble film comprises a second water soluble resin, preferably wherein the first water soluble resin comprises at least one polyvinyl alcohol homopolymer or at least one polyvinyl alcohol copolymer or a blend thereof and the second water soluble resin comprises at least one polyvinyl alcohol homopolymer or at least one polyvinyl alcohol copolymer or a blend thereof.
7. The use according to claim 6, wherein the first water soluble resin comprises a blend of a polyvinyl alcohol homopolymer and a polyvinyl alcohol copolymer comprising an anionic monomer unit, optionally wherein the blend comprises from 0% to 70% of the polyvinyl alcohol copolymer comprising an anionic monomer unit and from 30% to about 100% of the polyvinyl alcohol homopolymer, based on the total weight of the first water soluble resin in the first film, or wherein the blend comprises from 10% to 70%, or from 15% to about 65%, or from 20% to 50%, or from 30% to 40% of the polyvinyl alcohol copolymer comprising an anionic monomer unit, based on the total weight of the first water soluble resin in the first film.
8. The use according to claims 6 or 7, wherein the second water soluble resin comprises a blend of a polyvinyl alcohol homopolymer and a polyvinyl alcohol copolymer comprising an anionic monomer unit, optionally wherein the blend comprises from 0% to 70% of the polyvinyl alcohol copolymer comprising an anionic monomer unit and from 30% to 100% of the polyvinyl alcohol homopolymer, based on the total weight of the second water soluble resin in the second film, or wherein the blend comprises from 10% to 70%, or from 15% to 65%, or from 20% to 50%, or from 30% to 40% of the polyvinyl alcohol copolymer comprising an anionic monomer unit, based on the total weight of the second water soluble resin in the second film.

9. The water-soluble unit dose article of claim 7 or 8, wherein the first water soluble resin comprises from 65% by weight or greater of the first water soluble resin of the polyvinyl alcohol copolymer comprising an anionic monomer unit and the second water soluble resin comprises from 65% by weight or greater of the second water soluble resin of the polyvinyl alcohol copolymer comprising an anionic monomer unit.
10. The use according to any one of the preceding claims, wherein the anionic monomer unit is selected from the group consisting of anionic monomers derived from vinyl acetic acid, alkyl acrylates, maleic acid, monoalkyl maleate, dialkyl maleate, monomethyl maleate, dimethyl maleate, maleic anhydride, fumaric acid, monoalkyl fumarate, dialkyl fumarate, monomethyl fumarate, dimethyl fumarate, fumaric anhydride, itaconic acid, monomethyl itaconate, dimethyl itaconate, itaconic anhydride, citraconic acid, monoalkyl citraconate, dialkyl citraconate, citraconic anhydride, mesaconic acid, monoalkyl mesaconate, dialkyl mesaconate, mesaconic anhydride, glutaconic acid, monoalkyl glutaconate, dialkyl glutaconate, glutaconic anhydride, vinyl sulfonic acid, alkyl sulfonic acid, ethylene sulfonic acid, 2-acrylamido-1-methyl propane sulfonic acid, 2-acrylamide-2-methylpropanesulfonic acid, 2-methylacrylamido-2-methylpropanesulfonic acid, 2-sulfoethyl acrylate, alkali metal salts thereof, esters thereof, and combinations thereof, preferably, wherein the anionic monomer unit is selected from the group consisting of anionic monomers derived from maleic acid, monoalkyl maleate, dialkyl maleate, maleic anhydride, alkali metal salts thereof, esters thereof, and combinations thereof, more preferably wherein the anionic monomer unit is selected from the group consisting of anionic monomers derived from maleic acid, monomethyl maleate, dimethyl maleate, maleic anhydride, alkali metal salts thereof, esters thereof, and combinations thereof.
11. The use according to any one of the preceding claims wherein the first water-soluble film, and the second water-soluble film independently have a thickness before incorporation into the unit dose article of between 40 microns and 100 microns, preferably between 60 microns and 90 microns, more preferably between 70 microns and 80 microns, preferably wherein the difference in thickness before incorporation into the unit dose article between the first water-soluble film and the second water-

soluble film is less than 50%, preferably less than 30%, more preferably less than 20%, even more preferably less than 10%, or 0%.

12. The use according to any preceding claims wherein the first water-soluble film has a first water capacity and the second water-soluble film has a second water capacity wherein the first water capacity is less than the second water capacity and wherein the difference between the water capacity of the first water soluble film and the second water-soluble film is between 0.01% and 1%, preferably from 0.03% to 0.5%, more preferably from 0.05% to 0.3%.
13. The use according to claim 12, wherein the first water-soluble film has a water capacity from 1% to 10%, preferably from 2% to 8%, more preferably from 3 % to 6 % and the second water-soluble film has a water capacity from 1.5% to 12%, preferably from 2.5% to 10%, more preferably from 3.5 % to 8 %.
14. The use according to any one of the preceding claims wherein the user dosing experience comprises the user transferring at least one water-soluble unit dose article from a storage receptacle.
15. The use according to claim 14, wherein the transferring is by hand.
16. The use according to any one of the preceding claims wherein the user dosing experience comprises the user transferring at least one water-soluble unit dose article from a storage receptacle to an automatic washing machine, preferably the drum of an automatic washing machine by hand.
17. The use according to claim 16 wherein the storage receptacle is a flexible, preferably resealable, bag, a rigid, preferably recloseable, tub or a mixture thereof, preferably, wherein the storage receptacle comprises a child resistant closure.
18. The use according to any one of claims 16-17 wherein the improved user dosing experience comprises reduced instances of premature rupture of the water-soluble unit dose articles in the hand of the user whilst transferring them from the storage

receptacle to the automatic washing machine, preferably to the drum of an automatic washing machine.

19. The use according to any one of the preceding claims, wherein the unit dose article contains a non-household care composition.
20. The use according to claim 19, wherein the non-household care composition is selected from agricultural compositions, aviation compositions, food and nutritive compositions, industrial compositions, livestock compositions, marine compositions, medical compositions, mercantile compositions, military and quasi-military compositions, office compositions, and recreational and park compositions, pet compositions, water-treatment compositions.
21. The use according to claim 20, wherein the non-household care composition comprises an agricultural composition.
22. The use according to claim 20, wherein the non-household care composition comprises a water-treatment composition.

FIG. 1

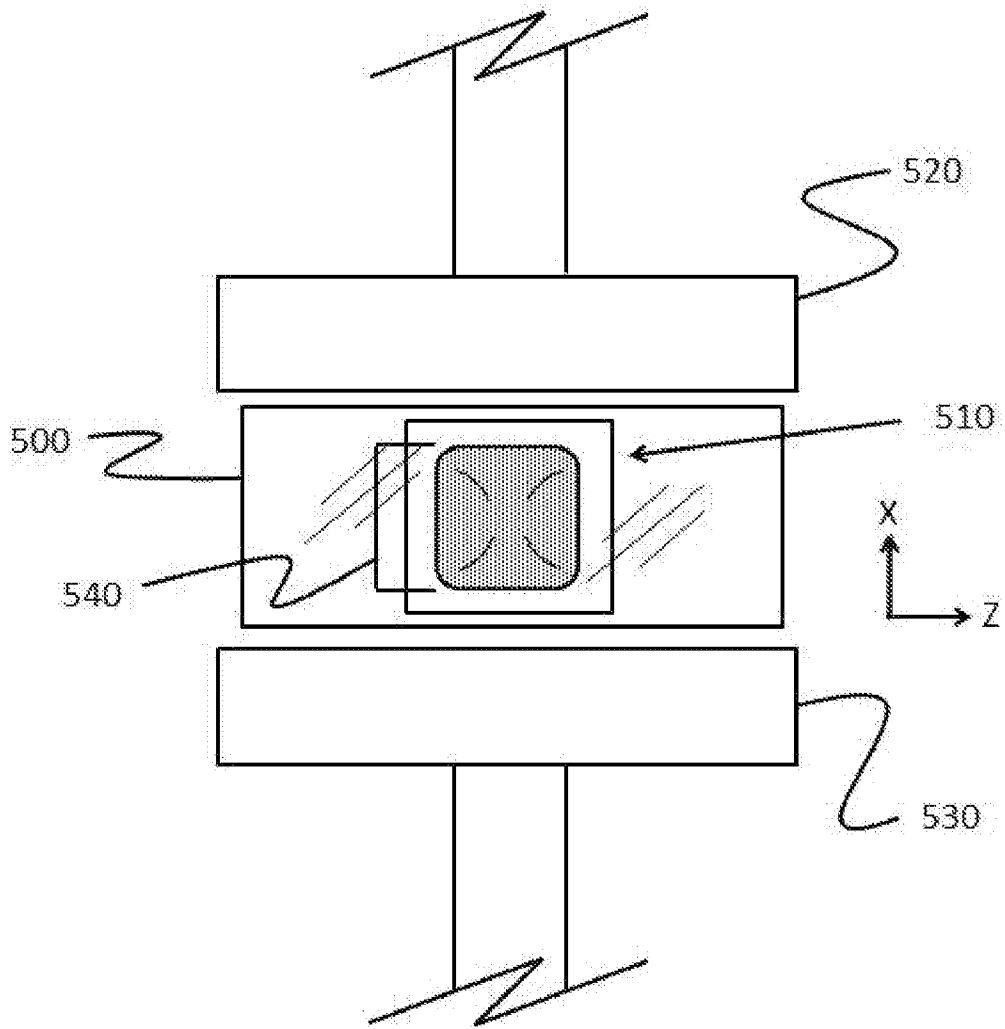

FIG. 2

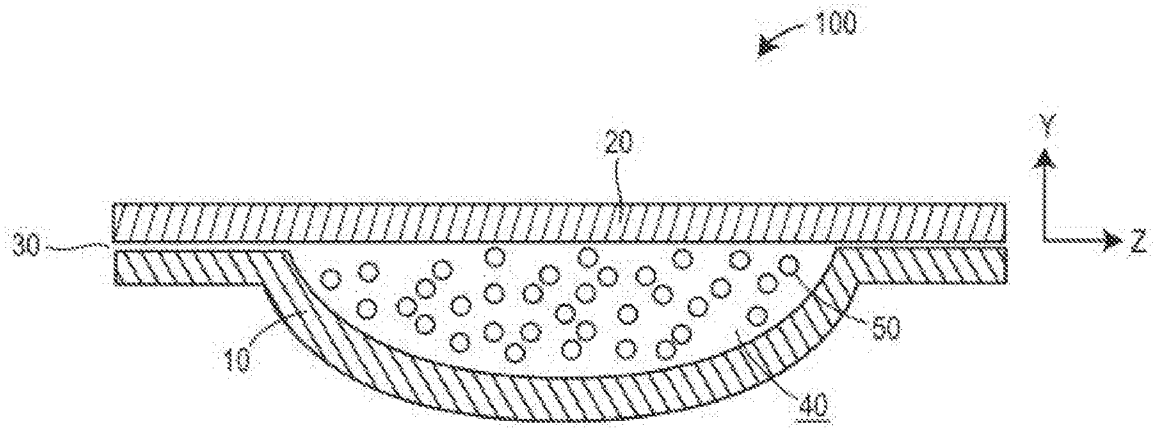
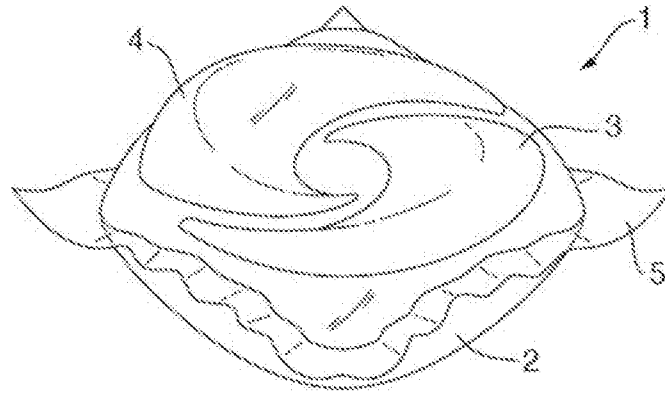

FIG. 3



INTERNATIONAL SEARCH REPORT

International application No
PCT/US2017/037008

A. CLASSIFICATION OF SUBJECT MATTER
INV. B65D65/46 C11D17/04
ADD.
According to International Patent Classification (IPC) or to both national classification and IPC

B. FIELDS SEARCHED
Minimum documentation searched (classification system followed by classification symbols)
B65D C11D

Documentation searched other than minimum documentation to the extent that such documents are included in the fields searched

Electronic data base consulted during the international search (name of data base and, where practicable, search terms used)
EPO-Internal, WPI Data

C. DOCUMENTS CONSIDERED TO BE RELEVANT

Category*	Citation of document, with indication, where appropriate, of the relevant passages	Relevant to claim No.
X	US 2016/102278 A1 (LABEQUE REGINE [BE] ET AL) 14 April 2016 (2016-04-14) example 11; tables 1, 7 paragraphs [0016] - [0020], [0056] - [0058], [0083] - [0086], [0159], [0173] - [0175], [0234] - [0236], [0241] - [0243]	1-22
A	WO 2008/087424 A1 (RECKITT BENCKISER NV [NL]; RECKITT BENCKISER UK LTD [GB]; MOREUX FREDE) 24 July 2008 (2008-07-24) figures 1, 2; table 1 page 28, line 8 - line 15 page 34, line 4 - page 36, line 12	1-22
A	WO 2016/061069 A2 (MONOSOL LLC [US]) 21 April 2016 (2016-04-21) figure 1; examples 6-10; table 1 paragraphs [0225] - [0227]	1-22

Further documents are listed in the continuation of Box C.

See patent family annex.

* Special categories of cited documents :

- "A" document defining the general state of the art which is not considered to be of particular relevance
- "E" earlier application or patent but published on or after the international filing date
- "L" document which may throw doubts on priority claim(s) or which is cited to establish the publication date of another citation or other special reason (as specified)
- "O" document referring to an oral disclosure, use, exhibition or other means
- "P" document published prior to the international filing date but later than the priority date claimed

- "T" later document published after the international filing date or priority date and not in conflict with the application but cited to understand the principle or theory underlying the invention
- "X" document of particular relevance; the claimed invention cannot be considered novel or cannot be considered to involve an inventive step when the document is taken alone
- "Y" document of particular relevance; the claimed invention cannot be considered to involve an inventive step when the document is combined with one or more other such documents, such combination being obvious to a person skilled in the art
- "&" document member of the same patent family

Date of the actual completion of the international search 16 August 2017	Date of mailing of the international search report 22/08/2017
------------------------------------------------------------------------------------	-------------------------------------------------------------------------

Name and mailing address of the ISA/ European Patent Office, P.B. 5818 Patentlaan 2 NL - 2280 HV Rijswijk Tel. (+31-70) 340-2040, Fax: (+31-70) 340-3016	Authorized officer Agra-Gutierrez, C
----------------------------------------------------------------------------------------------------------------------------------------------------------------------	------------------------------------------------

INTERNATIONAL SEARCH REPORT

Information on patent family members

International application No

PCT/US2017/037008

Patent document cited in search report	Publication date	Patent family member(s)	Publication date	
US 2016102278	A1	14-04-2016	AR 103786 A1	07-06-2017
			AU 2015333790 A1	20-04-2017
			CA 2962792 A1	21-04-2016
			CN 106795306 A	31-05-2017
			EP 3207083 A1	23-08-2017
			KR 20170052679 A	12-05-2017
			US 2016102278 A1	14-04-2016
			WO 2016061053 A1	21-04-2016

WO 2008087424	A1	24-07-2008	EP 2108041 A1	14-10-2009
			US 2010113318 A1	06-05-2010
			US 2015184116 A1	02-07-2015
			WO 2008087424 A1	24-07-2008

WO 2016061069	A2	21-04-2016	AU 2015333710 A1	27-04-2017
			CA 2963697 A1	21-04-2016
			EP 3207085 A2	23-08-2017
			KR 20170067866 A	16-06-2017
			US 2017226298 A1	10-08-2017
			WO 2016061069 A2	21-04-2016
