

(19) (KR)  
(12) (B1)

(51) 。 Int. Cl.7  
B01D 63/08  
B01D 63/16

(45)  
(11)  
(24)

2004 06 09  
10-0435162  
2004 05 31

(21) 10-2001-0007705  
(22) 2001 02 16

(65)  
(43)

10-2002-0067237  
2002 08 22

(73) 가 가  
1 1 14

(72) 1 1 14 가 가  
1 1 14 가 가  
1 1 14 가 가  
1 1 14 가 가

(74)  
:

(54)

(16) (18) (10) (16) 가 (18) (20)  
(22) 10mm (20) (22),(22)... (全周) 500mm 600mm 30° (20)

1  
 2  
 3 2 3 - 3  
 4 (逆流)  
 5  
 6  
 7 3  
 8 3  
 ( )  
 10 : 14 :  
 16 : 18 :  
 20 : 22 :

(濾過)

(全周)

(流速)

(低)

가

(逆流)

가

가

가

가

1 (10) (12) (12) (14) (14) (竝設)  
(10) (槽)( ) (原水)( )  
(14) (10)  
(14) (10) (10)  
2 (10) (10) 3 2 3 - 3  
(10) (16) (18)  
(16) ( ) (20)  
(18) 가 ( ) (10)  
(18) 가 (14) (送液) (14) (22)  
(10) 2 24 (液封) 가 (14) (20)  
(22)...가 (22),(22)... ( ) (10) )  
가 (18) ( ) (10)  
(10) 2 4 (34) (10) (34)  
(36) (38) (10) (38)가  
(10)가 700mm, (20)가 15mm 500mm  
(34) (22) 10mm 500mm 600mm 30°  
(22),(22)...가 (10)  
(12) (10) (10) (10) (18)  
(18)  
(10) (18) (18)  
5 700mm (10) (18) 5a (正)  
5b (10)  
5a (10) ( )  
(10) 가  
pm (正) 5b 50rpm 200r  
250mm (正)  
250mm  
(18) 가 (18) (18) (16)가  
가 (18) (18) (18) 4  
(18) (10) (18) (16) (18)

(10) (22)가 (22)가  
(10) (18) (18)  
(10) (18) (16) (22),(22)... ( (18)  
18) 가 40 60rpm 가 80 100rpm  
가  
(18) (18)  
(藥液)  
6 (10) 1.0m<sup>3</sup>/m<sup>2</sup>d, SS 10 15g/1  
, 27 3  
(18) (16)  
(20) 가 80rpm 가 60rpm  
가 20 , 30  
(18) 90 (10) 60rpm  
(18) (18) (22),(22)... (18) 가  
(10) 80rpm (18)  
(10) (18)  
(18) 500mm 600mm 30° (22),(22)...  
(22)  
, 7 (26) (28)가 (線形) (26)  
(18) (16)가 (18) (18) 가 (流線)  
(32)가 (30)  
(32) (40) (32)가  
(30) (32)  
(32)가 (30) 가 (30)  
(22) 7 8  
(22)가 (18) (16)  
(16) (16) (22) (18)  
(16) (16) 가

(57)

- 1.
- 2.
- 3.

1

1 2 , 가

4. 1 2 , 2

5. 1 2 , 가,

6. (流線) , , 가

7. , ,

2 , .

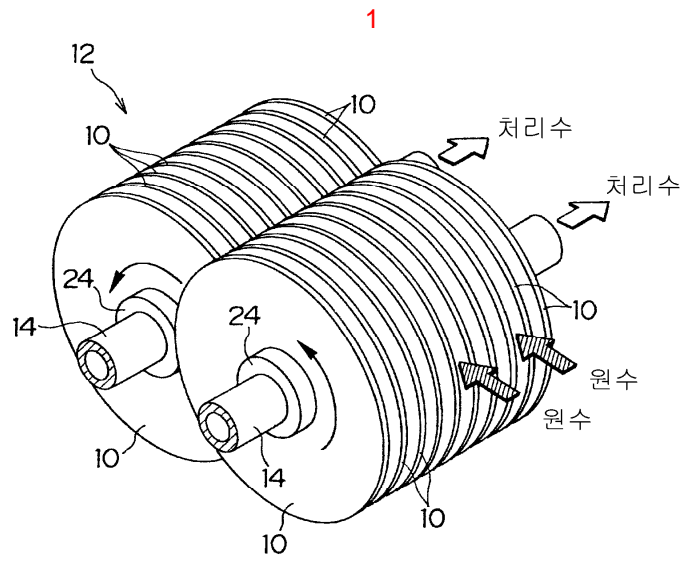

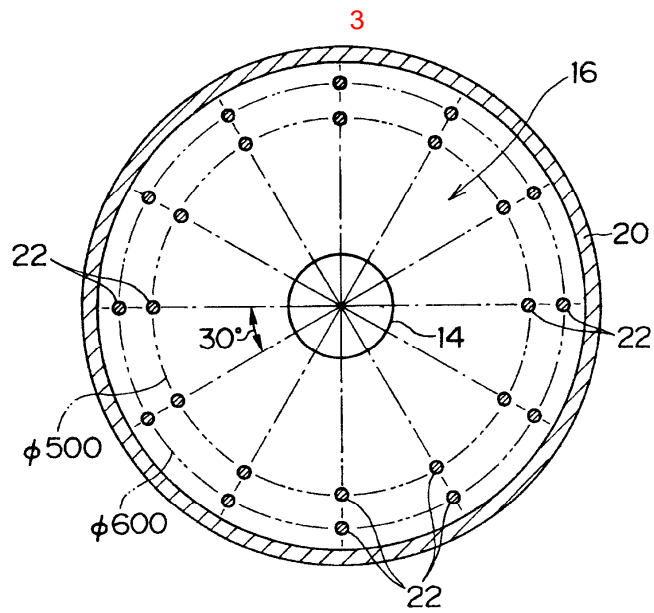
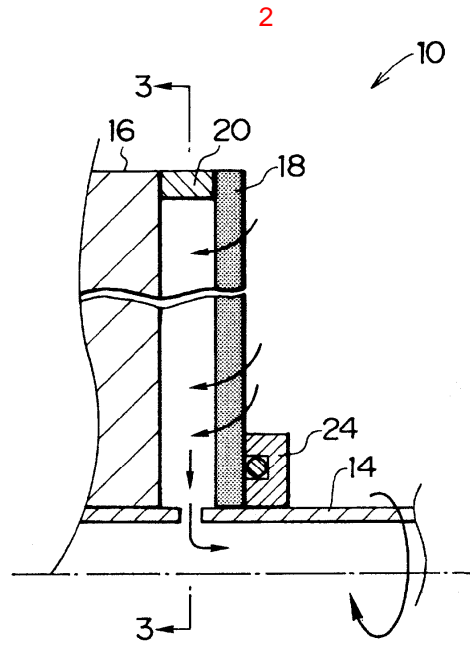

4

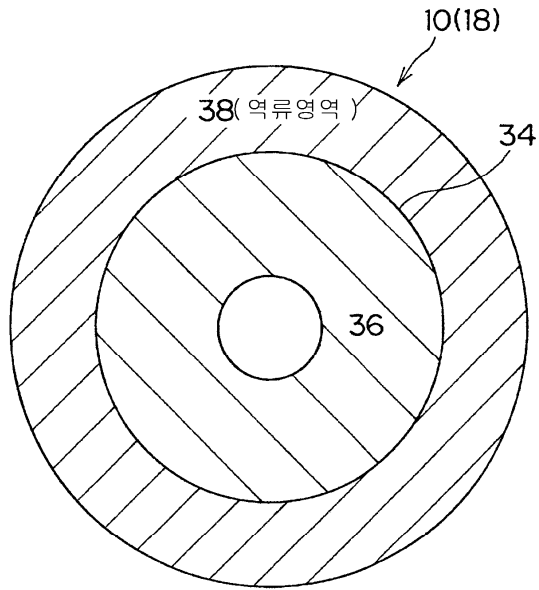

5a

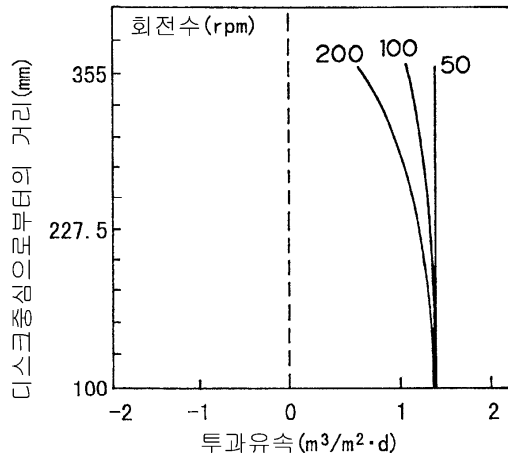

5b

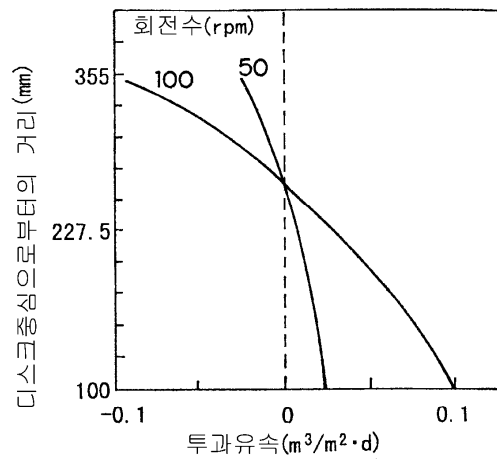

6

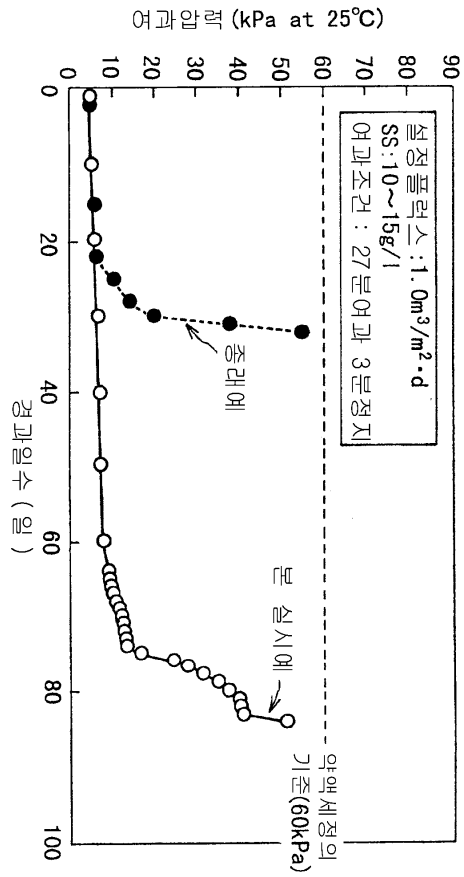

7

