

(12) STANDARD PATENT
(19) AUSTRALIAN PATENT OFFICE

(11) Application No. **AU 2018207289 B2**

(54) Title
Expandable intervertebral fusion device

(51) International Patent Classification(s)
A61F 2/44 (2006.01)

(21) Application No: **2018207289** (22) Date of Filing: **2018.01.10**

(87) WIPO No: **WO18/132502**

(30) Priority Data

(31) Number	(32) Date	(33) Country
62/481,565	2017.04.04	US
62/471,206	2017.03.14	US
62/444,663	2017.01.10	US

(43) Publication Date: **2018.07.19**

(44) Accepted Journal Date: **2023.03.16**

(71) Applicant(s)
Integrity Implants Inc.

(72) Inventor(s)
Shoshtaev, Eugene

(74) Agent / Attorney
Spruson & Ferguson, GPO Box 3898, Sydney, NSW, 2001, AU

(56) Related Art
WO 2014/164625 A1
WO 2016/019241 A1



(51) International Patent Classification:

A61F 2/44 (2006.01)

(21) International Application Number:

PCT/US2018/013207

(22) International Filing Date:

10 January 2018 (10.01.2018)

(25) Filing Language:

English

(26) Publication Language:

English

(30) Priority Data:

62/444,663	10 January 2017 (10.01.2017)	US
62/471,206	14 March 2017 (14.03.2017)	US
62/481,565	04 April 2017 (04.04.2017)	US

(71) Applicant: ANZA INNOVATIONS INC. [US/US]; 4916 Rancho Viejo Drive, Del Mar, CA 92014 (US).

(72) Inventor: SHOSHTAEV, Eugene; 4916 Rancho Viejo Drive, Del Mar, CA 92014 (US).

(74) Agent: ASHUR, Dor, Y.; Wilson Sonsini Goodrich & Rosati, 650 Page Mill Road, Palo Alto, CA 94304-1050 (US).

(81) Designated States (unless otherwise indicated, for every kind of national protection available): AE, AG, AL, AM, AO, AT, AU, AZ, BA, BB, BG, BH, BN, BR, BW, BY, BZ, CA, CH, CL, CN, CO, CR, CU, CZ, DE, DJ, DK, DM, DO, DZ, EC, EE, EG, ES, FI, GB, GD, GE, GH, GM, GT, HN, HR, HU, ID, IL, IN, IR, IS, JO, JP, KE, KG, KH, KN, KP, KR, KW, KZ, LA, LC, LK, LR, LS, LU, LY, MA, MD, ME, MG, MK, MN, MW, MX, MY, MZ, NA, NG, NI, NO, NZ, OM, PA, PE, PG, PH, PL, PT, QA, RO, RS, RU, RW, SA, SC, SD, SE, SG, SK, SL, SM, ST, SV, SY, TH, TJ, TM, TN, TR, TT, TZ, UA, UG, US, UZ, VC, VN, ZA, ZM, ZW.

(84) Designated States (unless otherwise indicated, for every kind of regional protection available): ARIPO (BW, GH, GM, KE, LR, LS, MW, MZ, NA, RW, SD, SL, ST, SZ, TZ,

UG, ZM, ZW), Eurasian (AM, AZ, BY, KG, KZ, RU, TJ, TM), European (AL, AT, BE, BG, CH, CY, CZ, DE, DK, EE, ES, FI, FR, GB, GR, HR, HU, IE, IS, IT, LT, LU, LV, MC, MK, MT, NL, NO, PL, PT, RO, RS, SE, SI, SK, SM, TR), OAPI (BF, BJ, CF, CG, CI, CM, GA, GN, GQ, GW, KM, ML, MR, NE, SN, TD, TG).

Declarations under Rule 4.17:

- as to applicant's entitlement to apply for and be granted a patent (Rule 4.17(ii))
- as to the applicant's entitlement to claim the priority of the earlier application (Rule 4.17(iii))

Published:

- with international search report (Art. 21(3))

(54) Title: EXPANDABLE INTERVERTEBRAL FUSION DEVICE

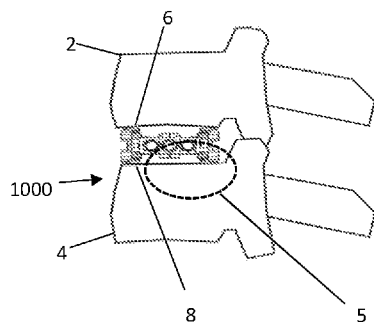

FIG. 2

(57) Abstract: The present invention provides an expandable fusion device capable of being installed inside an intervertebral disc space to maintain normal disc spacing and restore spinal stability, thereby facilitating an intervertebral fusion. The fusion device described herein is capable of being installed inside an intervertebral disc space at a minimum to no distraction height and for a fusion device capable of maintaining a normal distance between adjacent vertebral bodies when implanted.



EXPANDABLE INTERVERTEBRAL FUSION DEVICE

CROSS-REFERENCE

[0001] This application claims the benefit of U.S. Provisional Application Nos. 62/444, 663 (Attorney Docket No. 51624-703. 101), filed January 10, 2017, 62/471, 206 (Attorney Docket No. 51624-703. 102) filed March 14, 2017, and 62/481,565 (Attorney Docket No. 51624-703. 103) filed April 4, 2017; the entire contents of which is incorporated herein by reference.

BACKGROUND

[0001a] Any discussion of the prior art throughout the specification should in no way be considered as an admission that such prior art is widely known or forms part of common general knowledge in the field.

[0002] The present disclosure relates to medical devices and methods, and more preferably relates to the apparatus and method for promoting an intervertebral fusion, and more particularly relates to an expandable fusion device capable of being inserted between adjacent vertebrae to facilitate the fusion process.

[0003] A common procedure for handling pain associated with intervertebral discs that have become degenerated due to various factors such as trauma or aging is the use of intervertebral fusion devices for fusing one or more adjacent vertebral bodies. Generally, to fuse the adjacent vertebral bodies, the intervertebral disc is first partially or fully removed. An intervertebral fusion device is then typically inserted between neighboring vertebrae to maintain normal disc spacing and restore spinal stability, thereby facilitating an intervertebral fusion.

[0004] There are a number of known conventional fusion devices and methodologies in the art for accomplishing the intervertebral fusion. These include screw and rod arrangements, solid bone implants, and fusion devices which include a cage or other implant mechanism which, typically, is packed with bone and/or bone growth inducing substances. These devices are implanted between adjacent vertebral bodies in order to fuse the vertebral bodies together, alleviating the associated pain.

[0005] However, there are challenges associated with the known conventional fusion devices and methodologies. For example, present methods for installing a conventional fusion device may require that the adjacent vertebral bodies be distracted to restore a diseased disc space to its normal or healthy height prior to implantation of the fusion device. In order to maintain this height once the fusion device is inserted, the fusion device is usually dimensioned larger in height than the initial distraction height. This difference in height may make it difficult for a surgeon to install the fusion device in the distracted intervertebral space.

[0006] As such, there exists a need for a fusion device capable of being installed inside an intervertebral disc space at a minimum to no distraction height and for a fusion device capable of maintaining a normal distance between adjacent vertebral bodies when implanted.

[0007] One of the most common post-operative complications of intervertebral fusion surgery is intervertebral graft or cage subsidence which are minimized or mitigated by using an intervertebral cage or graft of a larger footprint. This is often difficult because to minimize the trauma and morbidity associated with spine surgery, it is often advantageous to utilize the smallest surgical access corridor possible to achieve the goals of surgery. As such there exists a need for a fusion device capable of being inserted through a relatively small surgical corridor and capable to then be expanded to a larger footprint suitable to resist subsidence.

[0008] The present device preferably is capable of meeting both of these criteria - being able to be inserted at a minimum to minimal or no intervertebral distraction and at a minimum width through a relatively small surgical corridor to then be expanded and maintained at a larger footprint suitable for resisting subsidence and at a greater height suitable for the goal of decompressing the neural elements and maintaining the intervertebral height as well as desirable alignment of the adjacent vertebral bodies. At least some of these objectives will be met by the exemplary embodiments disclosed herein.

DESCRIPTION OF THE BACKGROUND ART

[0009] 8,568,481; 8,926,704; 9,474,625; 9,138,328; 9,445,918; 2016/0317315; 2016/0324654; US20170056200A1; US9801734; US9795493; US9717601; US6821298; US20110035011A1; US9445918; US9480574; US6176882; US8105382; US8568481; US20160302940; US9561116; US9278008.

SUMMARY

[0009a] It is an object of the present invention to overcome or ameliorate at least one of the disadvantages of the prior art, or to provide a useful alternative.

[0009b] Unless the context clearly requires otherwise, throughout the description and the claims, the words “comprise”, “comprising”, and the like are to be construed in an inclusive sense as opposed to an exclusive or exhaustive sense; that is to say, in the sense of “including, but not limited to”.

[0010] Optionally, in any embodiment, the present disclosure provides an expandable fusion device capable of being inserted at a minimum to no intervertebral distraction and at a minimum width through a relatively small surgical corridor to then be expanded and maintained at a larger footprint suitable for resisting subsidence and at a greater height suitable for the goal of decompressing the neural elements and maintaining the intervertebral height as well as desirable alignment of the adjacent vertebral bodies.

[0010a] According to one aspect of the invention, there is provided an expandable device, comprising:
a first pair of endplates having a first upper endplate and a second upper endplate;
a second pair of endplates having the first upper endplate and a first lower endplate;
a translatable wedge configured to expand a width of the first pair of endplates; and,

a pair of ramps slidably coupled to the translatable wedge and configured to expand a height of the second pair of endplates; wherein,
a drawing of the translatable wedge using a single actuator expands the width of the first pair of endplates; and,
a further drawing of the translatable wedge using the single actuator expands the height of the second pair of endplates.

[0011] In another embodiment, the fusion device includes a proximal wedge, a distal wedge, a first ramp, a second ramp, a third ramp, a fourth ramp, a first endplate, a second endplate, a third endplate, a fourth endplate, an actuator and a retention member designed to constrain the linear motion of the actuator relative to the proximal wedge. The actuator capable of drawing the

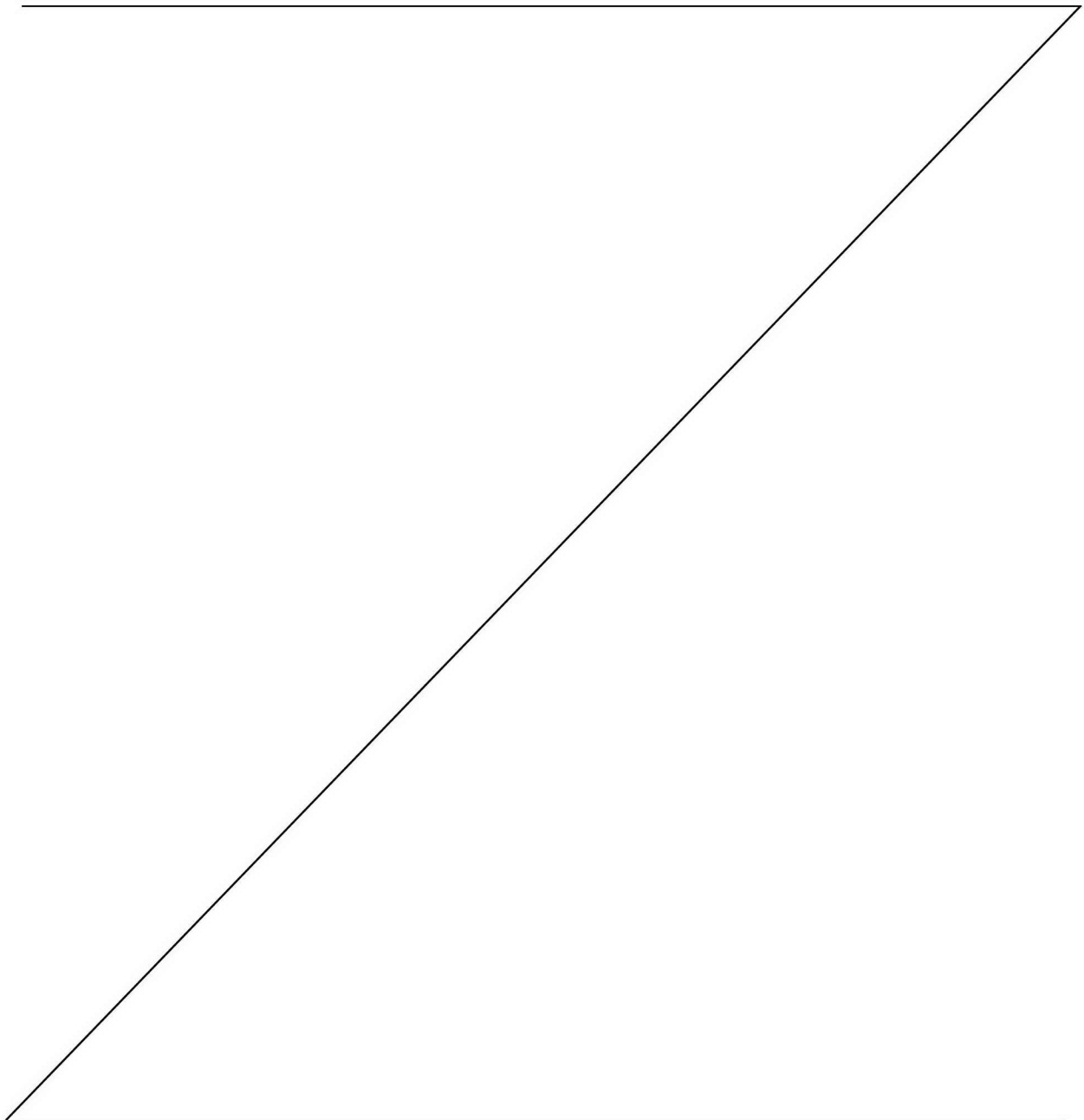

proximal wedge and the distal wedge together or apart from each other, forcing the first ramp away from the fourth ramp and forcing the second ramp away from the third ramp and also forcing the first ramp away from or toward the second ramp and forcing the third ramp away from or toward the fourth ramp, to result in moving the first endplate, the second endplate, the third endplate and the fourth endplate outwardly from each other and into an expanded configuration.

[0012] A first aspect provided herein is an expandable fusion device for implantation between two adjacent vertebrae, the device comprising: an actuator comprising a drive feature and a longitudinal axis; a wedge assembly coupled to the actuator; a ramp assembly slidably coupled with the wedge assembly; an upper endplate assembly slidably coupled with the ramp assembly; and a lower endplate assembly slidably coupled with the ramp assembly.

[0013] Optionally, in any embodiment, the device has a width comprising an external width of at least one of the upper endplate assembly and the lower endplate assembly. Optionally, in any embodiment, the device has a height comprising an external distance between the upper endplate assembly and the lower endplate assembly. Optionally, in any embodiment, actuation of the drive feature by a first number of actuations in a first actuation direction increases the width without increasing the height. Optionally, in any embodiment, actuation of the drive feature by a second number of actuations beyond the first number of actuations in the first actuation direction increases at least one of the height and the width.

[0014] Optionally, in any embodiment, the first number of actuations is about 0.5 actuations to about 10 actuations. Optionally, in any embodiment, the first number of actuations is at least about 0.5 actuations. Optionally, in any embodiment, the first number of actuations is at most about 10 actuations. Optionally, in any embodiment, the first number of actuations is about 0.5 actuations to about 1 actuations, about 0.5 actuations to about 1.5 actuations, about 0.5 actuations to about 2 actuations, about 0.5 actuations to about 2.5 actuations, about 0.5 actuations to about 3 actuations, about 0.5 actuations to about 3.5 actuations, about 0.5 actuations to about 4 actuations, about 0.5 actuations to about 5 actuations, about 0.5 actuations to about 6 actuations, about 0.5 actuations to about 8 actuations, about 0.5 actuations to about 10 actuations, about 1 actuations to about 1.5 actuations, about 1 actuations to about 2 actuations, about 1 actuations to about 2.5 actuations, about 1 actuations to about 3 actuations, about 1 actuations to about 3.5 actuations, about 1 actuations to about 4 actuations, about 1 actuations to about 5 actuations, about 1 actuations to about 6 actuations, about 1 actuations to about 8 actuations, about 1 actuations to about 10 actuations, about 1.5 actuations to about 2 actuations, about 1.5 actuations to about 2.5 actuations, about 1.5 actuations to about 3 actuations, about 1.5 actuations to about

3.5 actuations, about 1.5 actuations to about 4 actuations, about 1.5 actuations to about 5 actuations, about 1.5 actuations to about 6 actuations, about 1.5 actuations to about 8 actuations, about 1.5 actuations to about 10 actuations, about 2 actuations to about 2.5 actuations, about 2 actuations to about 3 actuations, about 2 actuations to about 3.5 actuations, about 2 actuations to about 4 actuations, about 2 actuations to about 5 actuations, about 2 actuations to about 6 actuations, about 2 actuations to about 8 actuations, about 2 actuations to about 10 actuations, about 2.5 actuations to about 3 actuations, about 2.5 actuations to about 3.5 actuations, about 2.5 actuations to about 4 actuations, about 2.5 actuations to about 5 actuations, about 2.5 actuations to about 6 actuations, about 2.5 actuations to about 8 actuations, about 2.5 actuations to about 10 actuations, about 3 actuations to about 3.5 actuations, about 3 actuations to about 4 actuations, about 3 actuations to about 5 actuations, about 3 actuations to about 6 actuations, about 3 actuations to about 8 actuations, about 3 actuations to about 10 actuations, about 3.5 actuations to about 4 actuations, about 3.5 actuations to about 5 actuations, about 3.5 actuations to about 6 actuations, about 3.5 actuations to about 8 actuations, about 3.5 actuations to about 10 actuations, about 4 actuations to about 5 actuations, about 4 actuations to about 6 actuations, about 4 actuations to about 8 actuations, about 4 actuations to about 10 actuations, about 5 actuations to about 6 actuations, about 5 actuations to about 8 actuations, about 5 actuations to about 10 actuations, about 6 actuations to about 8 actuations, about 6 actuations to about 10 actuations, or about 8 actuations to about 10 actuations. Optionally, in any embodiment, the first number of actuations is about 0.5 actuations, about 1 actuations, about 1.5 actuations, about 2 actuations, about 2.5 actuations, about 3 actuations, about 3.5 actuations, about 4 actuations, about 5 actuations, about 6 actuations, about 8 actuations, or about 10 actuations.

[0015] Optionally, in any embodiment, the second number of actuations is about 0.5 actuations to about 10 actuations. Optionally, in any embodiment, the second number of actuations is at least about 0.5 actuations. Optionally, in any embodiment, the second number of actuations is at most about 10 actuations. Optionally, in any embodiment, the second number of actuations is about 0.5 actuations to about 1 actuations, about 0.5 actuations to about 1.5 actuations, about 0.5 actuations to about 2 actuations, about 0.5 actuations to about 2.5 actuations, about 0.5 actuations to about 3 actuations, about 0.5 actuations to about 3.5 actuations, about 0.5 actuations to about 4 actuations, about 0.5 actuations to about 5 actuations, about 0.5 actuations to about 6 actuations, about 0.5 actuations to about 8 actuations, about 0.5 actuations to about 10 actuations, about 1 actuations to about 1.5 actuations, about 1 actuations to about 2 actuations, about 1 actuations to about 2.5 actuations, about 1 actuations to about 3 actuations, about 1 actuations to about 3.5 actuations, about 1 actuations to about 4 actuations, about 1 actuations to about 5 actuations,

about 1 actuations to about 6 actuations, about 1 actuations to about 8 actuations, about 1 actuations to about 10 actuations, about 1.5 actuations to about 2 actuations, about 1.5 actuations to about 2.5 actuations, about 1.5 actuations to about 3 actuations, about 1.5 actuations to about 3.5 actuations, about 1.5 actuations to about 4 actuations, about 1.5 actuations to about 5 actuations, about 1.5 actuations to about 6 actuations, about 1.5 actuations to about 8 actuations, about 1.5 actuations to about 10 actuations, about 2 actuations to about 2.5 actuations, about 2 actuations to about 3 actuations, about 2 actuations to about 3.5 actuations, about 2 actuations to about 4 actuations, about 2 actuations to about 5 actuations, about 2 actuations to about 6 actuations, about 2 actuations to about 8 actuations, about 2 actuations to about 10 actuations, about 2.5 actuations to about 3 actuations, about 2.5 actuations to about 3.5 actuations, about 2.5 actuations to about 4 actuations, about 2.5 actuations to about 5 actuations, about 2.5 actuations to about 6 actuations, about 2.5 actuations to about 8 actuations, about 2.5 actuations to about 10 actuations, about 3 actuations to about 3.5 actuations, about 3 actuations to about 4 actuations, about 3 actuations to about 5 actuations, about 3 actuations to about 6 actuations, about 3 actuations to about 8 actuations, about 3 actuations to about 10 actuations, about 3.5 actuations to about 4 actuations, about 3.5 actuations to about 5 actuations, about 3.5 actuations to about 6 actuations, about 3.5 actuations to about 8 actuations, about 3.5 actuations to about 10 actuations, about 4 actuations to about 5 actuations, about 4 actuations to about 6 actuations, about 4 actuations to about 8 actuations, about 4 actuations to about 10 actuations, about 5 actuations to about 6 actuations, about 5 actuations to about 8 actuations, about 5 actuations to about 10 actuations, about 6 actuations to about 8 actuations, about 6 actuations to about 10 actuations, or about 8 actuations to about 10 actuations. Optionally, in any embodiment, the second number of actuations is about 0.5 actuations, about 1 actuations, about 1.5 actuations, about 2 actuations, about 2.5 actuations, about 3 actuations, about 3.5 actuations, about 4 actuations, about 5 actuations, about 6 actuations, about 8 actuations, or about 10 actuations.

[0016] Optionally, in any embodiment, actuation of the drive feature by a second number of actuations beyond the first number of actuations in the first actuation direction increases both the height and the width. Optionally, in any embodiment, actuation of the drive feature by a second number of actuations beyond the first number of actuations in the first actuation direction increases the height without increasing the width.

[0017] Optionally, in any embodiment, the width of the device reaches an apex once the drive feature is actuated by at least the first number of actuations. Optionally, in any embodiment, the height of the device reaches an apex once the drive feature is actuated by at least the first and second number of actuations.

[0018] Optionally, in any embodiment, actuation of the drive feature in the first actuation direction by at least the first number of actuations increases the height of the device by about 30 % to about 400 %. Optionally, in any embodiment, actuation of the drive feature in the first actuation direction by at least the first number of actuations increases the height of the device by at least about 30 %. Optionally, in any embodiment, actuation of the drive feature in the first actuation direction by at least the first number of actuations increases the height of the device by at most about 400 %. Optionally, in any embodiment, actuation of the drive feature in the first actuation direction by at least the first number of actuations increases the height of the device by about 30 % to about 50 %, about 30 % to about 75 %, about 30 % to about 100 %, about 30 % to about 125 %, about 30 % to about 150 %, about 30 % to about 175 %, about 30 % to about 200 %, about 30 % to about 250 %, about 30 % to about 300 %, about 30 % to about 350 %, about 30 % to about 400 %, about 50 % to about 75 %, about 50 % to about 100 %, about 50 % to about 125 %, about 50 % to about 150 %, about 50 % to about 175 %, about 50 % to about 200 %, about 50 % to about 250 %, about 50 % to about 300 %, about 50 % to about 350 %, about 50 % to about 400 %, about 75 % to about 100 %, about 75 % to about 125 %, about 75 % to about 150 %, about 75 % to about 175 %, about 75 % to about 200 %, about 75 % to about 250 %, about 75 % to about 300 %, about 75 % to about 350 %, about 75 % to about 400 %, about 100 % to about 125 %, about 100 % to about 150 %, about 100 % to about 175 %, about 100 % to about 200 %, about 100 % to about 250 %, about 100 % to about 300 %, about 100 % to about 350 %, about 100 % to about 400 %, about 125 % to about 150 %, about 125 % to about 175 %, about 125 % to about 200 %, about 125 % to about 250 %, about 125 % to about 300 %, about 125 % to about 350 %, about 125 % to about 400 %, about 150 % to about 175 %, about 150 % to about 200 %, about 150 % to about 250 %, about 150 % to about 300 %, about 150 % to about 350 %, about 150 % to about 400 %, about 175 % to about 200 %, about 175 % to about 250 %, about 175 % to about 300 %, about 175 % to about 350 %, about 175 % to about 400 %, about 200 % to about 250 %, about 200 % to about 300 %, about 200 % to about 350 %, about 200 % to about 400 %, about 250 % to about 300 %, about 250 % to about 350 %, about 250 % to about 400 %, about 300 % to about 350 %, about 300 % to about 400 %, or about 350 % to about 400 %. Optionally, in any embodiment, actuation of the drive feature in the first actuation direction by at least the first number of actuations increases the height of the device by about 30 %, about 50 %, about 75 %, about 100 %, about 125 %, about 150 %, about 175 %, about 200 %, about 250 %, about 300 %, about 350 %, or about 400 %.

[0019] Optionally, in any embodiment, actuation of the drive feature in the first actuation direction by at least the first and the second number of actuations increases the width of the

device by about 14 % to about 150 %. Optionally, in any embodiment, actuation of the drive feature in the first actuation direction by at least the first and the second number of actuations increases the width of the device by at least about 14 %. Optionally, in any embodiment, actuation of the drive feature in the first actuation direction by at least the first and the second number of actuations increases the width of the device by at most about 150 %. Optionally, in any embodiment, actuation of the drive feature in the first actuation direction by at least the first and the second number of actuations increases the width of the device by about 14 % to about 20 %, about 14 % to about 30 %, about 14 % to about 40 %, about 14 % to about 50 %, about 14 % to about 60 %, about 14 % to about 70 %, about 14 % to about 80 %, about 14 % to about 100 %, about 14 % to about 120 %, about 14 % to about 140 %, about 14 % to about 150 %, about 20 % to about 30 %, about 20 % to about 40 %, about 20 % to about 50 %, about 20 % to about 60 %, about 20 % to about 70 %, about 20 % to about 80 %, about 20 % to about 100 %, about 20 % to about 120 %, about 20 % to about 140 %, about 20 % to about 150 %, about 30 % to about 40 %, about 30 % to about 50 %, about 30 % to about 60 %, about 30 % to about 70 %, about 30 % to about 80 %, about 30 % to about 100 %, about 30 % to about 120 %, about 30 % to about 140 %, about 30 % to about 150 %, about 40 % to about 50 %, about 40 % to about 60 %, about 40 % to about 70 %, about 40 % to about 80 %, about 40 % to about 100 %, about 40 % to about 120 %, about 40 % to about 140 %, about 40 % to about 150 %, about 50 % to about 60 %, about 50 % to about 70 %, about 50 % to about 80 %, about 50 % to about 100 %, about 50 % to about 120 %, about 50 % to about 140 %, about 50 % to about 150 %, about 60 % to about 70 %, about 60 % to about 80 %, about 60 % to about 100 %, about 60 % to about 120 %, about 60 % to about 140 %, about 60 % to about 150 %, about 70 % to about 80 %, about 70 % to about 100 %, about 70 % to about 120 %, about 70 % to about 140 %, about 70 % to about 150 %, about 80 % to about 100 %, about 80 % to about 120 %, about 80 % to about 140 %, about 80 % to about 150 %, about 100 % to about 120 %, about 100 % to about 140 %, about 100 % to about 150 %, about 120 % to about 140 %, about 120 % to about 150 %, or about 140 % to about 150 %.

Optionally, in any embodiment, actuation of the drive feature in the first actuation direction by at least the first and the second number of actuations increases the width of the device by about 14 %, about 20 %, about 30 %, about 40 %, about 50 %, about 60 %, about 70 %, about 80 %, about 100 %, about 120 %, about 140 %, or about 150 %.

[0020] Optionally, in any embodiment, the actuator has a distal end and a proximal end.

Optionally, in any embodiment, at least a portion of the distal end comprises a first thread feature. Optionally, in any embodiment, at least a portion of the proximal end comprises a second thread feature. Optionally, in any embodiment, the proximal end comprises the drive

feature. Optionally, in any embodiment, at least one of the first thread feature and the second thread feature comprise a thread disposed externally around the actuator. Optionally, in any embodiment, at least one of the first thread feature and the second thread feature has an opposite threading direction.

[0021] Optionally, in any embodiment, the wedge assembly comprises a distal wedge and a proximal wedge. Optionally, in any embodiment, actuation of the drive feature in the first direction converges the distal wedge and the proximal wedge toward one another. Optionally, in any embodiment, the distal wedge comprises a third thread feature, and wherein the third thread feature is threadably coupled to the first thread feature. Optionally, in any embodiment, the proximal wedge comprises a fourth thread feature, and wherein the fourth thread feature is threadably coupled to the second thread feature. Optionally, in any embodiment, the third thread feature comprises a thread disposed internally within the distal wedge. Optionally, in any embodiment, the fourth thread feature comprises a thread disposed internally within the proximal wedge.

[0022] Optionally, in any embodiment, the ramp assembly comprises a first distal ramp, a second distal ramp, a first proximal ramp, and a second proximal ramp. Optionally, in any embodiment, the slideable coupling between at least one of the wedge assembly and the ramp assembly, the ramp assembly and the upper endplate, assembly, and the ramp assembly and the lower endplate assembly is at a transverse angle from the longitudinal axis.

[0023] Optionally, in any embodiment, the transverse angle is about 0 degrees to about 90 degrees. Optionally, in any embodiment, the transverse angle is at least about 0 degrees. Optionally, in any embodiment, the transverse angle is at most about 90 degrees. Optionally, in any embodiment, the transverse angle is about 0 degrees to about 1 degrees, about 0 degrees to about 5 degrees, about 0 degrees to about 10 degrees, about 0 degrees to about 20 degrees, about 0 degrees to about 30 degrees, about 0 degrees to about 40 degrees, about 0 degrees to about 50 degrees, about 0 degrees to about 60 degrees, about 0 degrees to about 70 degrees, about 0 degrees to about 80 degrees, about 0 degrees to about 90 degrees, about 1 degrees to about 5 degrees, about 1 degrees to about 10 degrees, about 1 degrees to about 20 degrees, about 1 degrees to about 30 degrees, about 1 degrees to about 40 degrees, about 1 degrees to about 50 degrees, about 1 degrees to about 60 degrees, about 1 degrees to about 70 degrees, about 1 degrees to about 80 degrees, about 1 degrees to about 90 degrees, about 5 degrees to about 10 degrees, about 5 degrees to about 20 degrees, about 5 degrees to about 30 degrees, about 5 degrees to about 40 degrees, about 5 degrees to about 50 degrees, about 5 degrees to about 60 degrees, about 5 degrees to about 70 degrees, about 5 degrees to about 80 degrees, about 5

degrees to about 90 degrees, about 10 degrees to about 20 degrees, about 10 degrees to about 30 degrees, about 10 degrees to about 40 degrees, about 10 degrees to about 50 degrees, about 10 degrees to about 60 degrees, about 10 degrees to about 70 degrees, about 10 degrees to about 80 degrees, about 10 degrees to about 90 degrees, about 20 degrees to about 30 degrees, about 20 degrees to about 40 degrees, about 20 degrees to about 50 degrees, about 20 degrees to about 60 degrees, about 20 degrees to about 70 degrees, about 20 degrees to about 80 degrees, about 20 degrees to about 90 degrees, about 30 degrees to about 40 degrees, about 30 degrees to about 50 degrees, about 30 degrees to about 60 degrees, about 30 degrees to about 70 degrees, about 30 degrees to about 80 degrees, about 30 degrees to about 90 degrees, about 40 degrees to about 50 degrees, about 40 degrees to about 60 degrees, about 40 degrees to about 70 degrees, about 40 degrees to about 80 degrees, about 40 degrees to about 90 degrees, about 50 degrees to about 60 degrees, about 50 degrees to about 70 degrees, about 50 degrees to about 80 degrees, about 50 degrees to about 90 degrees, about 60 degrees to about 70 degrees, about 60 degrees to about 80 degrees, about 60 degrees to about 90 degrees, about 70 degrees to about 80 degrees, about 70 degrees to about 90 degrees, or about 80 degrees to about 90 degrees. Optionally, in any embodiment, the transverse angle is about 0 degrees, about 1 degrees, about 5 degrees, about 10 degrees, about 20 degrees, about 30 degrees, about 40 degrees, about 50 degrees, about 60 degrees, about 70 degrees, about 80 degrees, or about 90 degrees.

[0024] Optionally, in any embodiment, the slideable coupling between at least one of the wedge assembly and the ramp assembly, the ramp assembly and the upper endplate assembly, and the ramp assembly and the lower endplate assembly comprises a protrusion and a slot. Optionally, in any embodiment, the protrusion extends from at least one of the wedge assembly, the ramp assembly, the upper endplate assembly, and the lower endplate assembly, and wherein the slot is disposed in at least one of the upper endplate assembly, and the lower endplate assembly. Optionally, in any embodiment, the protrusion comprises a pin, a ridge, a dimple, a bolt, a screw, a bearing, or any combination thereof. Optionally, in any embodiment, the slot comprises a through slot, a blind slot, a t-slot, a v-slot, a groove, or any combination thereof.

[0025] Optionally, in any embodiment, the drive feature comprises a recessed region configured to receive a driving instrument. Optionally, in any embodiment, the recessed region comprises a slot, Phillips, pozidrive, frearson, robertson, 12-point flange, hex socket, security hex socket, star drive, security torx, ta, tri-point, tri-wing, spanner head, clutch, one-way, double-square, triple-square, polydrive, spline drive, double hex, bristol, a thread, a friction fit, or a pentalobe recess. Optionally, in any embodiment, the driving feature comprises a protuberance extending

therefrom and configured to be coupled to a driving instrument. Optionally, in any embodiment, the protuberance comprises a hex, a hexalobular, a threaded, or a square protuberance.

[0026] Optionally, in any embodiment, the upper endplate assembly comprises a first endplate and a second endplate, and wherein the lower endplate assembly comprises a third endplate and a fourth endplate. Optionally, in any embodiment, at least one of the first endplate and the second endplate, the third endplate and the fourth endplate, the first proximal ramp and the second proximal ramp, and the first distal ramp and the second distal ramp have mirrored equivalence. Optionally, in any embodiment, at least one of the second endplate and the fourth endplate is larger than at least one of the first endplate and the third endplate. Optionally, in any embodiment, at least one of the exterior faces of the first end plate, the second endplate, the third endplate, and the fourth endplate comprise a texture configured to grip the vertebrae. Optionally, in any embodiment, the texturing comprises a tooth, a ridge, a roughened area, a metallic coating, a ceramic coating, a keel, a spike, a projection, a groove, or any combination thereof.

[0027] Optionally, in any embodiment, at least one of the actuator, the wedge assembly, the ramp assembly, the upper endplate assembly, and the lower endplate assembly comprise titanium, cobalt, stainless steel, tantalum, platinum, PEEK, PEKK, carbon fiber, barium sulfate, hydroxyapatite, a ceramic, zirconium oxide, silicon nitride, carbon, bone graft, demineralized bone matrix product, synthetic bone substitute, a bone morphogenic agent, a bone growth inducing material, or any combination thereof.

[0028] A second aspect provided herein is an expandable fusion system for implantation between two adjacent vertebrae, the system comprising an inserter and an expandable fusion device comprising: an actuator comprising a drive feature and an longitudinal axis; a wedge assembly; a ramp assembly; an upper endplate assembly; and a lower endplate assembly; wherein the device has a width comprising an external distance between at least one of the first endplate and the third endplate, and the second endplate and the fourth endplate; wherein the device has a height comprising an external distance between at least one of the first endplate and the second endplate, and the third endplate and the fourth endplate; wherein actuation of the drive feature by a first number of actuations in a first actuation direction increases the width without increasing the height; and wherein actuation of the drive feature by a second number of actuations beyond the first number of actuations in the first actuation direction increases at least one of the height and the width.

[0029] Optionally, in any embodiment, actuation of the drive feature by a second number of actuations beyond the first number of actuations in the first actuation direction increases both the height and the width. Optionally, in any embodiment, actuation of the drive feature by a second

number of actuations beyond the first number of actuations in the first actuation direction increases the height without increasing the width.

[0030] Optionally, in any embodiment, the width of the device reaches an apex once the drive feature is actuated by at least the first number of actuations. Optionally, in any embodiment, the height of the device reaches an apex once the drive feature is actuated by at least the first and second number of actuations.

[0031] Optionally, in any embodiment, the first number of actuations is about 0.5 actuations to about 10 actuations. Optionally, in any embodiment, the first number of actuations is at least about 0.5 actuations. Optionally, in any embodiment, the first number of actuations is at most about 10 actuations. Optionally, in any embodiment, the first number of actuations is about 0.5 actuations to about 1 actuations, about 0.5 actuations to about 1.5 actuations, about 0.5 actuations to about 2 actuations, about 0.5 actuations to about 2.5 actuations, about 0.5 actuations to about 3 actuations, about 0.5 actuations to about 3.5 actuations, about 0.5 actuations to about 4 actuations, about 0.5 actuations to about 5 actuations, about 0.5 actuations to about 6 actuations, about 0.5 actuations to about 8 actuations, about 0.5 actuations to about 10 actuations, about 1 actuations to about 1.5 actuations, about 1 actuations to about 2 actuations, about 1 actuations to about 2.5 actuations, about 1 actuations to about 3 actuations, about 1 actuations to about 3.5 actuations, about 1 actuations to about 4 actuations, about 1 actuations to about 5 actuations, about 1 actuations to about 6 actuations, about 1 actuations to about 8 actuations, about 1 actuations to about 10 actuations, about 1.5 actuations to about 2 actuations, about 1.5 actuations to about 2.5 actuations, about 1.5 actuations to about 3 actuations, about 1.5 actuations to about 3.5 actuations, about 1.5 actuations to about 4 actuations, about 1.5 actuations to about 5 actuations, about 1.5 actuations to about 6 actuations, about 1.5 actuations to about 8 actuations, about 1.5 actuations to about 10 actuations, about 2 actuations to about 2.5 actuations, about 2 actuations to about 3 actuations, about 2 actuations to about 3.5 actuations, about 2 actuations to about 4 actuations, about 2 actuations to about 5 actuations, about 2 actuations to about 6 actuations, about 2 actuations to about 8 actuations, about 2 actuations to about 10 actuations, about 2.5 actuations to about 3 actuations, about 2.5 actuations to about 3.5 actuations, about 2.5 actuations to about 4 actuations, about 2.5 actuations to about 5 actuations, about 2.5 actuations to about 6 actuations, about 2.5 actuations to about 8 actuations, about 2.5 actuations to about 10 actuations, about 3 actuations to about 3.5 actuations, about 3 actuations to about 4 actuations, about 3 actuations to about 5 actuations, about 3 actuations to about 6 actuations, about 3 actuations to about 8 actuations, about 3 actuations to about 10 actuations, about 3.5 actuations to about 4 actuations, about 3.5 actuations to about 5 actuations, about 3.5 actuations to about 6

actuators, about 3.5 actuators to about 8 actuators, about 3.5 actuators to about 10 actuators, about 4 actuators to about 5 actuators, about 4 actuators to about 6 actuators, about 4 actuators to about 8 actuators, about 4 actuators to about 10 actuators, about 5 actuators to about 6 actuators, about 5 actuators to about 8 actuators, about 5 actuators to about 10 actuators, about 6 actuators to about 8 actuators, about 6 actuators to about 10 actuators, or about 8 actuators to about 10 actuators. Optionally, in any embodiment, the first number of actuators is about 0.5 actuators, about 1 actuators, about 1.5 actuators, about 2 actuators, about 2.5 actuators, about 3 actuators, about 3.5 actuators, about 4 actuators, about 5 actuators, about 6 actuators, about 8 actuators, or about 10 actuators.

[0032] Optionally, in any embodiment, the second number of actuators is about 0.5 actuators to about 10 actuators. Optionally, in any embodiment, the second number of actuators is at least about 0.5 actuators. Optionally, in any embodiment, the second number of actuators is at most about 10 actuators. Optionally, in any embodiment, the second number of actuators is about 0.5 actuators to about 1 actuators, about 0.5 actuators to about 1.5 actuators, about 0.5 actuators to about 2 actuators, about 0.5 actuators to about 2.5 actuators, about 0.5 actuators to about 3 actuators, about 0.5 actuators to about 3.5 actuators, about 0.5 actuators to about 4 actuators, about 0.5 actuators to about 5 actuators, about 0.5 actuators to about 6 actuators, about 0.5 actuators to about 8 actuators, about 0.5 actuators to about 10 actuators, about 1 actuators to about 1.5 actuators, about 1 actuators to about 2 actuators, about 1 actuators to about 2.5 actuators, about 1 actuators to about 3 actuators, about 1 actuators to about 3.5 actuators, about 1 actuators to about 4 actuators, about 1 actuators to about 5 actuators, about 1 actuators to about 6 actuators, about 1 actuators to about 8 actuators, about 1 actuators to about 10 actuators, about 1.5 actuators to about 2 actuators, about 1.5 actuators to about 2.5 actuators, about 1.5 actuators to about 3 actuators, about 1.5 actuators to about 3.5 actuators, about 1.5 actuators to about 4 actuators, about 1.5 actuators to about 5 actuators, about 1.5 actuators to about 6 actuators, about 1.5 actuators to about 8 actuators, about 1.5 actuators to about 10 actuators, about 2 actuators to about 2.5 actuators, about 2 actuators to about 3 actuators, about 2 actuators to about 3.5 actuators, about 2 actuators to about 4 actuators, about 2 actuators to about 5 actuators, about 2 actuators to about 6 actuators, about 2 actuators to about 8 actuators, about 2 actuators to about 10 actuators, about 2.5 actuators to about 3 actuators, about 2.5 actuators to about 3.5 actuators, about 2.5 actuators to about 4 actuators, about 2.5 actuators to about 5 actuators, about 2.5 actuators to about 6 actuators, about 2.5 actuators to about 8 actuators, about 2.5 actuators to about 10 actuators, about 3 actuators to about 3.5 actuators, about 3 actuators to about 4 actuators,

about 3 actuations to about 5 actuations, about 3 actuations to about 6 actuations, about 3 actuations to about 8 actuations, about 3 actuations to about 10 actuations, about 3.5 actuations to about 4 actuations, about 3.5 actuations to about 5 actuations, about 3.5 actuations to about 6 actuations, about 3.5 actuations to about 8 actuations, about 3.5 actuations to about 10 actuations, about 4 actuations to about 5 actuations, about 4 actuations to about 6 actuations, about 4 actuations to about 8 actuations, about 4 actuations to about 10 actuations, about 5 actuations to about 6 actuations, about 5 actuations to about 8 actuations, about 5 actuations to about 10 actuations, about 6 actuations to about 8 actuations, about 6 actuations to about 10 actuations, or about 8 actuations to about 10 actuations. Optionally, in any embodiment, the second number of actuations is about 0.5 actuations, about 1 actuations, about 1.5 actuations, about 2 actuations, about 2.5 actuations, about 3 actuations, about 3.5 actuations, about 4 actuations, about 5 actuations, about 6 actuations, about 8 actuations, or about 10 actuations.

[0033] Optionally, in any embodiment, actuation of the drive feature in the first actuation direction by at least the first number of actuations increases the height of the device by about 30 % to about 400 %. Optionally, in any embodiment, actuation of the drive feature in the first actuation direction by at least the first number of actuations increases the height of the device by at least about 30 %. Optionally, in any embodiment, actuation of the drive feature in the first actuation direction by at least the first number of actuations increases the height of the device by at most about 400 %. Optionally, in any embodiment, actuation of the drive feature in the first actuation direction by at least the first number of actuations increases the height of the device by about 30 % to about 50 %, about 30 % to about 75 %, about 30 % to about 100 %, about 30 % to about 125 %, about 30 % to about 150 %, about 30 % to about 175 %, about 30 % to about 200 %, about 30 % to about 250 %, about 30 % to about 300 %, about 30 % to about 350 %, about 30 % to about 400 %, about 50 % to about 75 %, about 50 % to about 100 %, about 50 % to about 125 %, about 50 % to about 150 %, about 50 % to about 175 %, about 50 % to about 200 %, about 50 % to about 250 %, about 50 % to about 300 %, about 50 % to about 350 %, about 50 % to about 400 %, about 75 % to about 100 %, about 75 % to about 125 %, about 75 % to about 150 %, about 75 % to about 175 %, about 75 % to about 200 %, about 75 % to about 250 %, about 75 % to about 300 %, about 75 % to about 350 %, about 75 % to about 400 %, about 100 % to about 125 %, about 100 % to about 150 %, about 100 % to about 175 %, about 100 % to about 200 %, about 100 % to about 250 %, about 100 % to about 300 %, about 100 % to about 350 %, about 100 % to about 400 %, about 125 % to about 150 %, about 125 % to about 175 %, about 125 % to about 200 %, about 125 % to about 250 %, about 125 % to about 300 %, about 125 % to about 350 %, about 125 % to about 400 %, about 150 % to about 175 %, about 150 %

to about 200 %, about 150 % to about 250 %, about 150 % to about 300 %, about 150 % to about 350 %, about 150 % to about 400 %, about 175 % to about 200 %, about 175 % to about 250 %, about 175 % to about 300 %, about 175 % to about 350 %, about 175 % to about 400 %, about 200 % to about 250 %, about 200 % to about 300 %, about 200 % to about 350 %, about 200 % to about 400 %, about 250 % to about 300 %, about 250 % to about 350 %, about 250 % to about 400 %, about 300 % to about 350 %, about 300 % to about 400 %, or about 350 % to about 400 %. Optionally, in any embodiment, actuation of the drive feature in the first actuation direction by at least the first number of actuations increases the height of the device by about 30 %, about 50 %, about 75 %, about 100 %, about 125 %, about 150 %, about 175 %, about 200 %, about 250 %, about 300 %, about 350 %, or about 400 %.

[0034] Optionally, in any embodiment, actuation of the drive feature in the first actuation direction by at least the first and the second number of actuations increases the width of the device by about 14 % to about 150 %. Optionally, in any embodiment, actuation of the drive feature in the first actuation direction by at least the first and the second number of actuations increases the width of the device by at least about 14 %. Optionally, in any embodiment, actuation of the drive feature in the first actuation direction by at least the first and the second number of actuations increases the width of the device by at most about 150 %. Optionally, in any embodiment, actuation of the drive feature in the first actuation direction by at least the first and the second number of actuations increases the width of the device by about 14 % to about 20 %, about 14 % to about 30 %, about 14 % to about 40 %, about 14 % to about 50 %, about 14 % to about 60 %, about 14 % to about 70 %, about 14 % to about 80 %, about 14 % to about 90 %, about 14 % to about 100 %, about 14 % to about 120 %, about 14 % to about 150 %, about 20 % to about 30 %, about 20 % to about 40 %, about 20 % to about 50 %, about 20 % to about 60 %, about 20 % to about 70 %, about 20 % to about 80 %, about 20 % to about 90 %, about 20 % to about 100 %, about 20 % to about 120 %, about 20 % to about 150 %, about 30 % to about 40 %, about 30 % to about 50 %, about 30 % to about 60 %, about 30 % to about 70 %, about 30 % to about 80 %, about 30 % to about 90 %, about 30 % to about 100 %, about 30 % to about 120 %, about 30 % to about 150 %, about 40 % to about 50 %, about 40 % to about 60 %, about 40 % to about 70 %, about 40 % to about 80 %, about 40 % to about 90 %, about 40 % to about 100 %, about 40 % to about 120 %, about 40 % to about 150 %, about 50 % to about 60 %, about 50 % to about 70 %, about 50 % to about 80 %, about 50 % to about 90 %, about 50 % to about 100 %, about 50 % to about 120 %, about 50 % to about 150 %, about 60 % to about 70 %, about 60 % to about 80 %, about 60 % to about 90 %, about 60 % to about 100 %, about 60 % to about 120 %, about 60 % to about 150 %, about 70 % to about 80 %, about 70 % to about 90 %, about

70 % to about 100 %, about 70 % to about 120 %, about 70 % to about 150 %, about 80 % to about 90 %, about 80 % to about 100 %, about 80 % to about 120 %, about 80 % to about 150 %, about 90 % to about 100 %, about 90 % to about 120 %, about 90 % to about 150 %, about 100 % to about 120 %, about 100 % to about 150 %, or about 120 % to about 150 %. Optionally, in any embodiment, actuation of the drive feature in the first actuation direction by at least the first and the second number of actuations increases the width of the device by about 14 %, about 20 %, about 30 %, about 40 %, about 50 %, about 60 %, about 70 %, about 80 %, about 90 %, about 100 %, about 120 %, or about 150 %.

[0035] Optionally, in any embodiment, the actuator has a distal end and a proximal end.

Optionally, in any embodiment, at least a portion of the distal end comprises a first thread feature. Optionally, in any embodiment, at least a portion of the proximal end comprises a second thread feature, and wherein the proximal end comprises the drive feature. Optionally, in any embodiment, at least one of the first thread feature and the second thread feature comprise a thread disposed externally around the actuator. Optionally, in any embodiment, the first thread feature and the second thread feature have an opposite threading direction.

[0036] Optionally, in any embodiment, the wedge assembly comprises a distal wedge and a proximal wedge. Optionally, in any embodiment, actuation of the drive feature in the first direction converges the distal wedge and the proximal wedge toward one another. Optionally, in any embodiment, the distal wedge comprises a third thread feature, and wherein the third thread feature is threadably coupled to the first thread feature. Optionally, in any embodiment, the proximal wedge comprises a fourth thread feature, and wherein the fourth thread feature is threadably coupled to the second thread feature. Optionally, in any embodiment, the third thread feature comprises a thread disposed internally within the distal wedge. Optionally, in any embodiment, the fourth thread feature comprises a thread disposed internally within the proximal wedge.

[0037] Optionally, in any embodiment, the ramp assembly comprises a first distal ramp, a second distal ramp, a first proximal ramp, and a second proximal ramp. Optionally, in any embodiment, the slideable coupling between at least one of the wedge assembly and the ramp assembly, the ramp assembly and the upper endplate, assembly, and the ramp assembly and the lower endplate assembly is at a transverse angle from the longitudinal axis. Optionally, in any embodiment, the transverse angle is about 0 degrees to about 90 degrees. Optionally, in any embodiment, the slideable coupling between at least one of the wedge assembly and the ramp assembly, the ramp assembly and the upper endplate, assembly, and the ramp assembly and the lower endplate assembly comprises a protrusion and a slot. Optionally, in any embodiment, the

protrusion extends from at least one of the wedge assembly, the ramp assembly, the upper endplate assembly, and the lower endplate assembly, and wherein the slot is disposed in at least one of the upper endplate assembly, and the lower endplate assembly. Optionally, in any embodiment, the protrusion comprises a pin, a ridge, a dimple, a bolt, a screw, a bearing, or any combination thereof. Optionally, in any embodiment, the slot comprises a through slot, a blind slot, a t-slot, a v-slot, a groove, or any combination thereof.

[0038] Optionally, in any embodiment, the drive feature comprises a recessed region configured to receive a driving instrument. Optionally, in any embodiment, the recessed region comprises a slot, Phillips, pozidrive, frearson, robertson, 12-point flange, hex socket, security hex socket, star drive, hexalobe, security torx, ta, tri-point, tri-wing, spanner head, clutch, one-way, double-square, triple-square, polydrive, spline drive, double hex, bristol, a thread, a friction fit, or a pentalobe recess or any other shaped recess. Optionally, in any embodiment, the driving feature comprises a protuberance extending therefrom and configured to be coupled to a driving instrument. Optionally, in any embodiment, the protuberance comprises a hex, a hexalobular, a threaded, or a square protuberance or any other shape protuberance.

[0039] Optionally, in any embodiment, the upper endplate assembly comprises a first endplate and a second endplate, and wherein the lower endplate assembly comprises a third endplate and a fourth endplate. Optionally, in any embodiment, at least one of the first endplate and the second endplate, the third endplate and the fourth endplate, the first proximal ramp and the second proximal ramp, and the first distal ramp and the second distal ramp have mirrored equivalence. Optionally, in any embodiment, at least one of the second endplate and the fourth endplate is larger than at least one of the first endplate and the third endplate. Optionally, in any embodiment, at least one of the exterior faces of the first end plate, the second endplate, the third endplate, and the fourth endplate comprise a texture configured to grip the vertebrae. Optionally, in any embodiment, the texturing comprises a tooth, a ridge, a roughened area, a metallic coating, a ceramic coating, a keel, a spike, a projection, a groove, or any combination thereof.

[0040] Optionally, in any embodiment, at least one of the actuator, the wedge assembly, the upper endplate assembly, and the lower endplate assembly comprise titanium, cobalt, stainless steel, tantalum, platinum, PEEK, PEKK, PEI, PET, carbon fiber, barium sulfate, hydroxyapatite, a ceramic, zirconium oxide, silicon nitride, carbon, bone graft, demineralized bone matrix product, synthetic bone substitute, a bone morphogenic agent, a bone growth inducing material, or any combination thereof.

[0041] A third aspect provided herein is a method for implanting an expandable fusion device between two adjacent vertebrae comprising: inserting the device, having a width and a height,

between two adjacent vertebrae; actuating a drive feature by a first number of actuations in a first actuation to increase the width without increasing the height; and actuating the drive feature by the second number of actuations beyond the first number of actuations in the first actuation direction to increase at least one of the height and the width; attaching an inserter to the expandable fusion device, the device having a width and a height and comprising a drive feature.

[0042] Optionally, in any embodiment, actuation of the drive feature by a second number of actuations beyond the first number of actuations in the first actuation direction increases both the height and the width. Optionally, in any embodiment, actuation of the drive feature by a second number of actuations beyond the first number of actuations in the first actuation direction increases the height without increasing the width.

[0043] Optionally, in any embodiment, the width of the device reaches an apex once the drive feature is actuated by at least the first number of actuations. Optionally, in any embodiment, the height of the device reaches an apex once the drive feature is actuated by at least the first and second number of actuations.

[0044] Optionally, in any embodiment, the first number of actuations is about 0.5 actuations to about 10 actuations. Optionally, in any embodiment, the first number of actuations is at least about 0.5 actuations. Optionally, in any embodiment, the first number of actuations is at most about 10 actuations. Optionally, in any embodiment, the first number of actuations is about 0.5 actuations to about 1 actuations, about 0.5 actuations to about 1.5 actuations, about 0.5 actuations to about 2 actuations, about 0.5 actuations to about 2.5 actuations, about 0.5 actuations to about 3 actuations, about 0.5 actuations to about 3.5 actuations, about 0.5 actuations to about 4 actuations, about 0.5 actuations to about 5 actuations, about 0.5 actuations to about 6 actuations, about 0.5 actuations to about 8 actuations, about 0.5 actuations to about 10 actuations, about 1 actuations to about 1.5 actuations, about 1 actuations to about 2 actuations, about 1 actuations to about 2.5 actuations, about 1 actuations to about 3 actuations, about 1 actuations to about 3.5 actuations, about 1 actuations to about 4 actuations, about 1 actuations to about 5 actuations, about 1 actuations to about 6 actuations, about 1 actuations to about 8 actuations, about 1 actuations to about 10 actuations, about 1.5 actuations to about 2 actuations, about 1.5 actuations to about 2.5 actuations, about 1.5 actuations to about 3 actuations, about 1.5 actuations to about 3.5 actuations, about 1.5 actuations to about 4 actuations, about 1.5 actuations to about 5 actuations, about 1.5 actuations to about 6 actuations, about 1.5 actuations to about 8 actuations, about 1.5 actuations to about 10 actuations, about 2 actuations to about 2.5 actuations, about 2 actuations to about 3 actuations, about 2 actuations to about 3.5 actuations, about 2 actuations to about 4 actuations, about 2 actuations to about 5 actuations, about 2 actuations to about 6

actuations, about 2 actuations to about 8 actuations, about 2 actuations to about 10 actuations, about 2.5 actuations to about 3 actuations, about 2.5 actuations to about 3.5 actuations, about 2.5 actuations to about 4 actuations, about 2.5 actuations to about 5 actuations, about 2.5 actuations to about 6 actuations, about 2.5 actuations to about 8 actuations, about 2.5 actuations to about 10 actuations, about 3 actuations to about 3.5 actuations, about 3 actuations to about 4 actuations, about 3 actuations to about 5 actuations, about 3 actuations to about 6 actuations, about 3 actuations to about 8 actuations, about 3 actuations to about 10 actuations, about 3.5 actuations to about 4 actuations, about 3.5 actuations to about 5 actuations, about 3.5 actuations to about 6 actuations, about 3.5 actuations to about 8 actuations, about 3.5 actuations to about 10 actuations, about 4 actuations to about 5 actuations, about 4 actuations to about 6 actuations, about 4 actuations to about 8 actuations, about 4 actuations to about 10 actuations, about 5 actuations to about 6 actuations, about 5 actuations to about 8 actuations, about 5 actuations to about 10 actuations, about 6 actuations to about 8 actuations, about 6 actuations to about 10 actuations, or about 8 actuations to about 10 actuations. Optionally, in any embodiment, the first number of actuations is about 0.5 actuations, about 1 actuations, about 1.5 actuations, about 2 actuations, about 2.5 actuations, about 3 actuations, about 3.5 actuations, about 4 actuations, about 5 actuations, about 6 actuations, about 8 actuations, or about 10 actuations.

[0045] Optionally, in any embodiment, the second number of actuations is about 0.5 actuations to about 10 actuations. Optionally, in any embodiment, the second number of actuations is at least about 0.5 actuations. Optionally, in any embodiment, the second number of actuations is at most about 10 actuations. Optionally, in any embodiment, the second number of actuations is about 0.5 actuations to about 1 actuations, about 0.5 actuations to about 1.5 actuations, about 0.5 actuations to about 2 actuations, about 0.5 actuations to about 2.5 actuations, about 0.5 actuations to about 3 actuations, about 0.5 actuations to about 3.5 actuations, about 0.5 actuations to about 4 actuations, about 0.5 actuations to about 5 actuations, about 0.5 actuations to about 6 actuations, about 0.5 actuations to about 8 actuations, about 0.5 actuations to about 10 actuations, about 1 actuations to about 1.5 actuations, about 1 actuations to about 2 actuations, about 1 actuations to about 2.5 actuations, about 1 actuations to about 3 actuations, about 1 actuations to about 3.5 actuations, about 1 actuations to about 4 actuations, about 1 actuations to about 5 actuations, about 1 actuations to about 6 actuations, about 1 actuations to about 8 actuations, about 1 actuations to about 10 actuations, about 1.5 actuations to about 2 actuations, about 1.5 actuations to about 2.5 actuations, about 1.5 actuations to about 3 actuations, about 1.5 actuations to about 3.5 actuations, about 1.5 actuations to about 4 actuations, about 1.5 actuations to about 5 actuations, about 1.5 actuations to about 6 actuations, about 1.5 actuations to about 8 actuations,

about 1.5 actuations to about 10 actuations, about 2 actuations to about 2.5 actuations, about 2 actuations to about 3 actuations, about 2 actuations to about 3.5 actuations, about 2 actuations to about 4 actuations, about 2 actuations to about 5 actuations, about 2 actuations to about 6 actuations, about 2 actuations to about 8 actuations, about 2 actuations to about 10 actuations, about 2.5 actuations to about 3 actuations, about 2.5 actuations to about 3.5 actuations, about 2.5 actuations to about 4 actuations, about 2.5 actuations to about 5 actuations, about 2.5 actuations to about 6 actuations, about 2.5 actuations to about 8 actuations, about 2.5 actuations to about 10 actuations, about 3 actuations to about 3.5 actuations, about 3 actuations to about 4 actuations, about 3 actuations to about 5 actuations, about 3 actuations to about 6 actuations, about 3 actuations to about 8 actuations, about 3 actuations to about 10 actuations, about 3.5 actuations to about 4 actuations, about 3.5 actuations to about 5 actuations, about 3.5 actuations to about 6 actuations, about 3.5 actuations to about 8 actuations, about 3.5 actuations to about 10 actuations, about 4 actuations to about 5 actuations, about 4 actuations to about 6 actuations, about 4 actuations to about 8 actuations, about 4 actuations to about 10 actuations, about 5 actuations to about 6 actuations, about 5 actuations to about 8 actuations, about 5 actuations to about 10 actuations, about 6 actuations to about 8 actuations, about 6 actuations to about 10 actuations, or about 8 actuations to about 10 actuations. Optionally, in any embodiment, the second number of actuations is about 0.5 actuations, about 1 actuations, about 1.5 actuations, about 2 actuations, about 2.5 actuations, about 3 actuations, about 3.5 actuations, about 4 actuations, about 5 actuations, about 6 actuations, about 8 actuations, or about 10 actuations.

[0046] Optionally, in any embodiment, actuation of the drive feature in the first actuation direction by at least the first number of actuations increases the height of the device by about 30 % to about 400 %. Optionally, in any embodiment, actuation of the drive feature in the first actuation direction by at least the first number of actuations increases the height of the device by at least about 30 %. Optionally, in any embodiment, actuation of the drive feature in the first actuation direction by at least the first number of actuations increases the height of the device by at most about 400 %. Optionally, in any embodiment, actuation of the drive feature in the first actuation direction by at least the first number of actuations increases the height of the device by about 30 % to about 50 %, about 30 % to about 75 %, about 30 % to about 100 %, about 30 % to about 125 %, about 30 % to about 150 %, about 30 % to about 175 %, about 30 % to about 200 %, about 30 % to about 250 %, about 30 % to about 300 %, about 30 % to about 350 %, about 30 % to about 400 %, about 50 % to about 75 %, about 50 % to about 100 %, about 50 % to about 125 %, about 50 % to about 150 %, about 50 % to about 175 %, about 50 % to about 200 %, about 50 % to about 250 %, about 50 % to about 300 %, about 50 % to about 350 %, about 50 %

to about 400 %, about 75 % to about 100 %, about 75 % to about 125 %, about 75 % to about 150 %, about 75 % to about 175 %, about 75 % to about 200 %, about 75 % to about 250 %, about 75 % to about 300 %, about 75 % to about 350 %, about 75 % to about 400 %, about 100 % to about 125 %, about 100 % to about 150 %, about 100 % to about 175 %, about 100 % to about 200 %, about 100 % to about 250 %, about 100 % to about 300 %, about 100 % to about 350 %, about 100 % to about 400 %, about 125 % to about 150 %, about 125 % to about 175 %, about 125 % to about 200 %, about 125 % to about 250 %, about 125 % to about 300 %, about 125 % to about 350 %, about 125 % to about 400 %, about 150 % to about 175 %, about 150 % to about 200 %, about 150 % to about 250 %, about 150 % to about 300 %, about 150 % to about 350 %, about 150 % to about 400 %, about 175 % to about 200 %, about 175 % to about 250 %, about 175 % to about 300 %, about 175 % to about 350 %, about 175 % to about 400 %, about 200 % to about 250 %, about 200 % to about 300 %, about 200 % to about 350 %, about 200 % to about 400 %, about 250 % to about 300 %, about 250 % to about 350 %, about 250 % to about 400 %, about 300 % to about 350 %, about 300 % to about 400 %, or about 350 % to about 400 %. Optionally, in any embodiment, actuation of the drive feature in the first actuation direction by at least the first number of actuations increases the height of the device by about 30 %, about 50 %, about 75 %, about 100 %, about 125 %, about 150 %, about 175 %, about 200 %, about 250 %, about 300 %, about 350 %, or about 400 %.

[0047] Optionally, in any embodiment, actuation of the drive feature in the first actuation direction by at least the first and the second number of actuations increases the width of the device by about 14 % to about 150 %. Optionally, in any embodiment, actuation of the drive feature in the first actuation direction by at least the first and the second number of actuations increases the width of the device by at least about 14 %. Optionally, in any embodiment, actuation of the drive feature in the first actuation direction by at least the first and the second number of actuations increases the width of the device by at most about 150 %. Optionally, in any embodiment, actuation of the drive feature in the first actuation direction by at least the first and the second number of actuations increases the width of the device by about 14 % to about 20 %, about 14 % to about 30 %, about 14 % to about 40 %, about 14 % to about 50 %, about 14 % to about 60 %, about 14 % to about 70 %, about 14 % to about 80 %, about 14 % to about 100 %, about 14 % to about 120 %, about 14 % to about 140 %, about 14 % to about 150 %, about 20 % to about 30 %, about 20 % to about 40 %, about 20 % to about 50 %, about 20 % to about 60 %, about 20 % to about 70 %, about 20 % to about 80 %, about 20 % to about 100 %, about 20 % to about 120 %, about 20 % to about 140 %, about 20 % to about 150 %, about 30 % to about 40 %, about 30 % to about 50 %, about 30 % to about 60 %, about 30 % to about 70 %, about 30

% to about 80 %, about 30 % to about 100 %, about 30 % to about 120 %, about 30 % to about 140 %, about 30 % to about 150 %, about 40 % to about 50 %, about 40 % to about 60 %, about 40 % to about 70 %, about 40 % to about 80 %, about 40 % to about 100 %, about 40 % to about 120 %, about 40 % to about 140 %, about 40 % to about 150 %, about 50 % to about 60 %, about 50 % to about 70 %, about 50 % to about 80 %, about 50 % to about 100 %, about 50 % to about 120 %, about 50 % to about 140 %, about 50 % to about 150 %, about 60 % to about 70 %, about 60 % to about 80 %, about 60 % to about 100 %, about 60 % to about 120 %, about 60 % to about 140 %, about 60 % to about 150 %, about 70 % to about 80 %, about 70 % to about 100 %, about 70 % to about 120 %, about 70 % to about 140 %, about 70 % to about 150 %, about 80 % to about 100 %, about 80 % to about 120 %, about 80 % to about 140 %, about 80 % to about 150 %, about 100 % to about 120 %, about 100 % to about 140 %, about 100 % to about 150 %, about 120 % to about 140 %, about 120 % to about 150 %, or about 140 % to about 150 %.

Optionally, in any embodiment, actuation of the drive feature in the first actuation direction by at least the first and the second number of actuations increases the width of the device by about 14 %, about 20 %, about 30 %, about 40 %, about 50 %, about 60 %, about 70 %, about 80 %, about 100 %, about 120 %, about 140 %, or about 150 %.

[0048] Optionally, in any embodiment, the actuator has a distal end and a proximal end.

Optionally, in any embodiment, at least a portion of the distal end comprises a first thread feature. Optionally, in any embodiment, at least a portion of the proximal end comprises a second thread feature, and wherein the proximal end comprises the drive feature. Optionally, in any embodiment, at least one of the first thread feature and the second thread feature comprise a thread disposed externally around the actuator. Optionally, in any embodiment, the first thread feature and the second thread feature have an opposite threading direction.

[0049] Optionally, in any embodiment, the wedge assembly comprises a distal wedge and a proximal wedge. Optionally, in any embodiment, actuation of the drive feature in the first direction converges the distal wedge and the proximal wedge toward one another. Optionally, in any embodiment, the distal wedge comprises a third thread feature, and wherein the third thread feature is threadably coupled to the first thread feature. Optionally, in any embodiment, the proximal wedge comprises a fourth thread feature, and wherein the fourth thread feature is threadably coupled to the second thread feature. Optionally, in any embodiment, the third thread feature comprises a thread disposed internally within the distal wedge. Optionally, in any embodiment, the fourth thread feature comprises a thread disposed internally within the proximal wedge.

[0050] Optionally, in any embodiment, the ramp assembly comprises a first distal ramp, a second distal ramp, a first proximal ramp, and a second proximal ramp. Optionally, in any embodiment, the slideable coupling between at least one of the wedge assembly and the ramp assembly, the ramp assembly and the upper endplate assembly, and the ramp assembly and the lower endplate assembly is at a transverse angle from the longitudinal axis. Optionally, in any embodiment, the transverse angle is about 30 degrees to about 90 degrees. Optionally, in any embodiment, the slideable coupling between at least one of the wedge assembly and the ramp assembly, the ramp assembly and the upper endplate assembly, and the ramp assembly and the lower endplate assembly comprises a protrusion and a slot. Optionally, in any embodiment, the protrusion extends from at least one of the wedge assembly, the ramp assembly, the upper endplate assembly, and the lower endplate assembly, and wherein the slot is disposed in at least one of the upper endplate assembly, and the lower endplate assembly. Optionally, in any embodiment, the protrusion comprises a pin, a ridge, a dimple, a bolt, a screw, a bearing, or any combination thereof. Optionally, in any embodiment, the slot comprises a through slot, a blind slot, a t-slot, a v-slot, a groove, or any combination thereof.

[0051] Optionally, in any embodiment, the drive feature comprises a recessed region configured to receive a driving instrument. Optionally, in any embodiment, the recessed region comprises a slot, Phillips, pozidrive, frearson, robertson, 12-point flange, hex socket, security hex socket, star drive, security torx, ta, tri-point, tri-wing, spanner head, clutch, one-way, double-square, triple-square, polydrive, spline drive, double hex, bristol, a thread, a friction fit, or a pentalobe recess. Optionally, in any embodiment, the driving feature comprises a protuberance extending therefrom and configured to be coupled to a driving instrument. Optionally, in any embodiment, the protuberance comprises a hex, a hexalobular, a threaded a square protuberance.

[0052] Optionally, in any embodiment, the upper endplate assembly comprises a first endplate and a second endplate, and wherein the lower endplate assembly comprises a third endplate and a fourth endplate. Optionally, in any embodiment, at least one of the first endplate and the second endplate, the third endplate and the fourth endplate, the first proximal ramp and the second proximal ramp, and the first distal ramp and the second distal ramp have mirrored equivalence. Optionally, in any embodiment, at least one of the second endplate and the fourth endplate is larger than at least one of the first endplate and the third endplate. Optionally, in any embodiment, at least one of the exterior faces of the first end plate, the second endplate, the third endplate, and the fourth endplate comprise a texture configured to grip the vertebrae. Optionally, in any embodiment, the texturing comprises a tooth, a ridge, a roughened area, a metallic coating, a ceramic coating, a keel, a spike, a projection, a groove, or any combination thereof.

[0053] Optionally, in any embodiment, at least one of the actuator, the wedge assembly, the upper endplate assembly, and the lower endplate assembly comprise titanium, cobalt, stainless steel, tantalum, platinum, PEEK, PEKK, carbon fiber, barium sulfate, hydroxyapatite, a ceramic, zirconium oxide, silicon nitride, carbon, bone graft, demineralized bone matrix product, synthetic bone substitute, a bone morphogenic agent, a bone growth inducing material, or any combination thereof.

[0054] Further areas of applicability of the present disclosure will become apparent from the detailed description provided hereinafter. It should be understood that the detailed description and specific examples, while indicating the preferred or exemplary embodiments of the disclosure, are intended for purposes of illustration only and are not intended to limit the scope of the disclosure.

BRIEF DESCRIPTION OF THE DRAWINGS

[0055] The novel features of the disclosure are set forth with particularity in the appended claims. A better understanding of the features and advantages of the present disclosure will be obtained by reference to the following detailed description that sets forth illustrative embodiments, in which the principles of the disclosure are utilized, and the accompanying drawings of which:

[0056] **FIG. 1** depicts an exemplary first expandable fusion device implanted between two vertebral bodies in initial collapsed state.

[0057] **FIG. 2** depicts an exemplary first expandable fusion device implanted between two vertebral bodies in fully expanded state.

[0058] **FIG. 3** depicts a perspective view of an exemplary first expandable fusion device in its initial collapsed state.

[0059] **FIG. 4** depicts a perspective view of an exemplary first expandable fusion device in its fully expanded state.

[0060] **FIG. 5** depicts an exploded view of an exemplary first expandable fusion device.

[0061] **FIG. 6A** depicts a planar top view of an exemplary first expandable fusion device in initial collapsed state.

[0062] **FIG. 6B** depicts a planar end view of an exemplary first expandable fusion device in initial collapsed state.

[0063] **FIG. 6C** depicts a planar top view of an exemplary first expandable fusion device fully expanded in width.

[0064] **FIG. 6D** depicts a planar end view of an exemplary first expandable fusion device fully expanded in width.

[0065] FIG. 6E depicts a planar top view of an exemplary first expandable fusion device fully expanded in both width and height.

[0066] FIG. 6F depicts a planar end view of an exemplary first expandable fusion device fully expanded in both width and height.

[0067] FIG. 7A depicts a detailed view of an exemplary first expandable fusion device in its initial collapsed state and illustrates the articulation responsible for delay in height expansion.

[0068] FIG. 7B depicts a detailed view of an exemplary first expandable fusion device in a partially width expanded state.

[0069] FIG. 7C depicts a detailed view of an exemplary first expandable fusion device in a partially width and height expanded state.

[0070] FIG. 8A depicts a bottom view of an exemplary endplate.

[0071] FIG. 8B depicts a top view of an exemplary endplate.

[0072] FIG. 9A depicts an exemplary endplate with T-shaped slots.

[0073] FIG. 9B depicts an exemplary endplate with L-shaped slots.

[0074] FIG. 9C depicts an exemplary endplate with Y-shaped slots.

[0075] FIG. 9D depicts an exemplary endplate with F-shaped slots.

[0076] FIG. 9E depicts an exemplary endplate with rectilinear slots.

[0077] FIG. 10A depicts a perspective top view of an exemplary endplate.

[0078] FIG. 10B depicts a bottom view of an exemplary endplate.

[0079] FIG. 10C depicts a perspective view of an exemplary first expandable fusion device in fully expanded state.

[0080] FIG. 10D1 depicts a perspective view of an exemplary first expandable fusion device in initial collapsed state.

[0081] FIG. 10D2 depicts a perspective view of an exemplary first expandable fusion device in fully expanded state.

[0082] FIG. 10D3 depicts a perspective view of an exemplary first expandable fusion device in fully expanded state and assembled with bone fasteners.

[0083] FIG. 11A depicts end view of an exemplary first expandable fusion device with all planar endplates.

[0084] FIG. 11B depicts end view of an exemplary first expandable fusion device with all convex endplates.

[0085] FIG. 11C depicts end view of an exemplary first expandable fusion device with all individually convex endplates.

- [0086] FIG. 11D depicts end view of an exemplary first expandable fusion device with all planar endplates, with some of the endplates having different heights.
- [0087] FIG. 11E depicts end view of an exemplary first expandable fusion device with the top and bottom plates generally convex and lordotic.
- [0088] FIG. 11F depicts end view of an exemplary first expandable fusion device with all convex endplates, with some of the endplates having different heights.
- [0089] FIG. 11G depicts end view of an exemplary first expandable fusion device with flat and lordotic endplates.
- [0090] FIG. 11H depicts end view of an exemplary first expandable fusion device with flat bottom endplates, individually convex top endplates having different lengths.
- [0091] FIG. 11I depicts end view of an exemplary first expandable fusion device with two generally convex top endplates and two flat bottom endplates.
- [0092] FIG. 12A depicts side view of an exemplary first expandable fusion device with all planar endplates.
- [0093] FIG. 12B depicts side view of an exemplary first expandable fusion device with all domed endplates.
- [0094] FIG. 12C depicts side view of an exemplary first expandable fusion device with all planar and ramped endplates.
- [0095] FIG. 12D depicts end view of an exemplary first expandable fusion device with all planar and domed endplates.
- [0096] FIG. 13A depicts top view of an exemplary first expandable fusion device with all endplates of same length in initial collapsed state.
- [0097] FIG. 13B depicts top view of an exemplary first expandable fusion device with endplates of different lengths in initial collapsed state.
- [0098] FIG. 13C depicts top view of an exemplary first expandable fusion device with all endplates of same length in fully width expanded state.
- [0099] FIG. 13D depicts top view of an exemplary first expandable fusion device with endplates of different lengths in fully width expanded state.
- [0100] FIG. 14A depicts side views of the height expansion of an exemplary first expandable fusion device.
- [0101] FIG. 14B1 depicts a top view of the collapsed state of an exemplary first expandable fusion device configured to expand unevenly on both ends.

[0102] **FIG. 14B2** depicts a top view of a fully expanded state of an exemplary first expandable fusion device with an alternative expansion mechanism and designed to expand unevenly on both ends.

[0103] **FIG. 15A** depicts side views of the width expansion of an exemplary first expandable fusion device.

[0104] **FIG. 15B** depicts a top view of an initial collapsed state of an exemplary first expandable fusion device with different length endplates designed to achieve more width expansion on one side than on the other.

[0105] **FIG. 15C** depicts a top view of a fully width expanded state of an exemplary first expandable fusion device with different length endplates designed to achieve more width expansion on one side than on the other.

[0106] **FIG. 15D** depicts a perspective view of a fully expanded state of an exemplary first expandable fusion device with different length endplates designed to achieve more width expansion on one side than on the other.

[0107] **FIG. 15E** depicts a perspective view of an exemplary distal wedge with uneven ramps.

[0108] **FIG. 15F** depicts a perspective view of an exemplary proximal wedge with uneven ramps.

[0109] **FIG. 15G** depicts a perspective view of an exemplary ramp.

[0110] **FIG. 16** depicts end views of the height expansion of an exemplary first expandable fusion device.

[0111] **FIG. 17A** depicts an inside perspective view of an exemplary ramp.

[0112] **FIG. 17B** depicts an outside perspective view of an exemplary ramp.

[0113] **FIG. 18A** depicts an inside perspective view of an exemplary ramp with L-shaped branches.

[0114] **FIG. 18B** depicts an inside perspective view of an exemplary ramp with C-shaped branches.

[0115] **FIG. 18C** depicts an inside perspective view of an exemplary ramp with T-shaped branches and T-shaped channel.

[0116] **FIG. 18D** depicts an inside perspective view of an exemplary ramp with Y-shaped branches and Y-shaped channel.

[0117] **FIG. 18E** depicts an inside perspective view of an exemplary ramp with an inside T-shaped branches and Y-shaped channel.

[0118] **FIG. 19A** depicts an inside perspective view of an exemplary ramp with cylindrical branches of rectilinear cross-section.

[0119] FIG. 19B depicts an outside perspective view of an exemplary ramp with cylindrical branches of rectilinear cross-section.

[0120] FIG. 19C depicts an inside perspective view of an exemplary ramp with cylindrical branches of L-shaped cross-section.

[0121] FIG. 19D depicts an outside perspective view of an exemplary ramp with cylindrical branches of L-shaped cross-section.

[0122] FIG. 19E depicts an inside perspective view of an exemplary ramp with cylindrical branches of T-shaped cross-section.

[0123] FIG. 19F depicts an outside perspective view of an exemplary ramp with cylindrical branches of T-shaped cross-section.

[0124] FIG. 19G1 depicts a detailed section view of articulation between an exemplary ramp and of an exemplary endplate in unassembled state.

[0125] FIG. 19G2 depicts a detailed section view of articulation an exemplary ramp and an exemplary endplate in a partially assembled state.

[0126] FIG. 19G3 depicts a detailed section view of articulation between an exemplary ramp and of an exemplary endplate in a fully assembled state, in which the travel range of a ramp is limited.

[0127] FIG. 19H1 depicts detailed view of articulation between an exemplary ramp, an exemplary endplate, and an exemplary fastener in which the travel range of a ramp is limited.

[0128] FIG. 19H2 depicts detailed exploded view of articulation between an exemplary ramp, an exemplary endplate, and an exemplary fastener in which the travel range of a ramp is limited.

[0129] FIG. 20 depicts a perspective view of an embodiment of an exemplary actuator.

[0130] FIG. 21A depicts a perspective view of an exemplary actuator.

[0131] FIG. 21B depicts a perspective view of an exemplary actuator.

[0132] FIG. 22 depicts a perspective view of an exemplary retaining pin.

[0133] FIG. 23 depicts a perspective view of an exemplary retaining set screw.

[0134] FIG. 24 depicts a perspective view of an exemplary retaining c-clip.

[0135] FIG. 25 depicts a section view of articulation between an exemplary proximal wedge, an exemplary actuator, and an exemplary retaining c-clip.

[0136] FIG. 26A depicts a rear perspective view of an exemplary proximal wedge.

[0137] FIG. 26B depicts a front perspective view of an exemplary proximal wedge.

[0138] FIG. 27A depicts a perspective view of an exemplary proximal wedge with T-shaped projections.

[0139] FIG. 27B depicts a perspective view of an exemplary proximal wedge with threaded central aperture and alternative instrument attachment features.

[0140] FIG. 27C depicts a perspective view of an exemplary proximal wedge with T-shaped projections and alternative instrument attachment features.

[0141] FIG. 27D depicts a perspective view of an exemplary proximal wedge with T-shaped projections, alternative instrument attachment features and an alternative side aperture shape.

[0142] FIG. 28A depicts a front perspective view of an exemplary distal wedge.

[0143] FIG. 28B depicts a rear perspective view of an exemplary distal wedge.

[0144] FIG. 29A depicts a front perspective view of an exemplary distal wedge with T-shaped projections.

[0145] FIG. 29B depicts a front perspective view of an exemplary distal wedge with T-shaped projections and without side apertures.

[0146] FIG. 30 depicts a perspective view of an exemplary inserter instrument.

[0147] FIG. 31 depicts a perspective view of an exemplary inserter instrument.

[0148] FIG. 32 depicts a detailed perspective view of the distal end of an exemplary inserter instrument.

[0149] FIG. 33 depicts a perspective view of an exemplary expansion driver instrument.

[0150] FIG. 34 depicts a perspective view of an exemplary first expandable fusion device attached to an exemplary inserter instrument.

[0151] FIG. 35 depicts an exemplary first expandable fusion device implanted between two vertebral bodies in an initial collapsed state while having an exemplary inserter instrument attached to it.

[0152] FIG. 36 depicts a perspective view of an exemplary first expandable fusion device attached to an exemplary inserter instrument with an exemplary expansion driver instrument.

[0153] FIG. 37 depicts a detailed perspective view of an exemplary first expandable fusion device attached to an exemplary inserter instrument.

[0154] FIG. 38 depicts a detailed perspective view of an exemplary first expandable fusion device in a partially width expanded state attached to an exemplary inserter instrument.

[0155] FIG. 39 depicts a detailed perspective view of an exemplary first expandable fusion device in a fully width expanded state attached to an exemplary inserter instrument.

[0156] FIG. 40 depicts a detailed perspective view of an exemplary first expandable fusion device in a fully width and height expanded state attached to an exemplary inserter instrument.

[0157] **FIG. 41** depicts a perspective view of an exemplary first expandable fusion device in a fully width and height expanded state filled with graft material and attached to an exemplary inserter instrument.

[0158] **FIG. 42** depicts an exemplary first expandable fusion device implanted between two vertebral bodies in a fully expanded state and filled with graft material.

[0159] **FIG. 43** depicts an exemplary inserter instrument.

[0160] **FIG. 44** depicts a detailed section view of an exemplary actuation mechanism of an exemplary inserter instrument.

[0161] **FIG. 45** depicts a detailed view of the distal end of the main shaft of an exemplary inserter instrument.

[0162] **FIG. 46** depicts a detailed view of the distal end of an exemplary inserter instrument.

[0163] **FIG. 47** depicts a detailed section view of the articulation between an exemplary first expandable fusion device and an exemplary inserter instrument.

[0164] **FIG. 48** depicts a detailed perspective view of an exemplary first expandable fusion device in an initial collapsed state attached to an exemplary inserter instrument in an unlocked state.

[0165] **FIG. 49** depicts a detailed perspective view of an exemplary first expandable fusion device in an initial collapsed state attached to an exemplary inserter instrument in a locked state.

[0166] **FIG. 50** depicts a perspective view of an exemplary first expandable fusion device attached to an exemplary inserter instrument with an exemplary expansion driver instrument.

[0167] **FIG. 51** depicts a perspective view of an exemplary first expandable fusion device in a fully width expanded state attached to an exemplary inserter instrument.

[0168] **FIG. 52** depicts a perspective view of an exemplary first expandable fusion device in a fully width and height expanded state and attached to an exemplary inserter instrument.

[0169] **FIG. 53** depicts a perspective view of an exemplary first expandable fusion device in a fully width and height expanded state filled with graft material and attached to an exemplary inserter instrument.

[0170] **FIG. 54A** depicts a perspective view of an exemplary second expandable fusion device in an initial collapsed state.

[0171] **FIG. 54B** depicts a perspective view of an exemplary second expandable fusion device of **FIG. 54A** in a fully expanded state.

[0172] **FIG. 54C** depicts an exploded view of an exemplary second expandable fusion device.

[0173] **FIG. 55A** depicts a front view of an exemplary proximal wedge, used in an exemplary second expandable fusion device of **Figs. 54A-54C**.

[0174] **FIG. 55B** depicts a rear view of an exemplary proximal wedge, used in an exemplary second expandable fusion device of **Figs. 54A-54C**.

[0175] **FIG. 56A** depicts a perspective view of an exemplary third expandable fusion device in an initial collapsed state.

[0176] **FIG. 56B** depicts a perspective view of an exemplary third expandable fusion in a fully expanded state.

[0177] **FIG. 56C** depicts an exploded view of an exemplary third expandable fusion device.

[0178] **FIG. 57A** depicts a right view of an exemplary ramp of an exemplary third expandable fusion device.

[0179] **FIG. 57B** depicts a left view of an exemplary ramp of an exemplary third expandable fusion device.

[0180] **FIG. 58** depicts a bottom view of an exemplary endplate of an exemplary third expandable fusion device.

[0181] **FIG. 59A** depicts a perspective view of an exemplary fourth expandable fusion device in an initial collapsed state.

[0182] **FIG. 59B** depicts a perspective view of an exemplary fourth expandable fusion device of **FIG. 59A** in a fully expanded state.

[0183] **FIG. 59C** depicts a top view of an exemplary fourth expandable fusion device of **FIG. 59A** in an initial fully collapsed state.

[0184] **FIG. 59D** depicts a perspective view of partial assembly of an exemplary fourth expandable fusion device comprising two opposing endplates.

[0185] **FIG. 60A** depicts a perspective view of an exemplary fifth expandable fusion device in a fully expanded state.

[0186] **FIG. 60B** depicts a side view of an exemplary fifth expandable fusion device of **FIG. 60A** in a fully expanded state.

[0187] **FIG. 61A** depicts a perspective view of an exemplary sixth expandable fusion device in a fully expanded state.

[0188] **FIG. 61B** depicts an exploded view of an exemplary sixth expandable fusion device.

[0189] **FIG. 62A** depicts a perspective view of an exemplary seventh expandable fusion device in a fully expanded state.

[0190] **FIG. 62B** depicts an exploded view of an exemplary seventh expandable fusion device.

[0191] **FIG. 63A** depicts a perspective view of an exemplary eighth expandable fusion device in an initial collapsed state.

[0192] **FIG. 63B** depicts a perspective view of an exemplary eighth expandable fusion device in a fully width expanded state.

[0193] **FIG. 63C** depicts a perspective view of an exemplary eighth expandable fusion device in a fully expanded state.

[0194] **FIG. 63D** depicts an exploded view of an exemplary eighth expandable fusion.

[0195] **FIG. 64** depicts a perspective view of an exemplary eighth proximal wedge, used in an exemplary expandable fusion device.

[0196] **FIG. 65A** depicts a perspective view of an exemplary ninth expandable fusion device in an initial collapsed state.

[0197] **FIG. 65B** depicts a perspective view of an exemplary ninth expandable fusion device in a fully expanded state.

[0198] **FIG. 65C** depicts a partially assembled perspective view of an exemplary ninth expandable fusion device in an initial collapsed state.

[0199] **FIG. 65D** depicts a partially assembled perspective view of an exemplary ninth expandable fusion device in a partially width expanded state (linear width expansion only).

[0200] **FIG. 65E** depicts a partially assembled perspective view of an exemplary ninth expandable fusion device in a fully width expanded state (both linear and angular expansion completed).

[0201] **FIG. 66A** depicts a perspective view of an exemplary tenth expandable fusion device in a fully expanded state.

[0202] **FIG. 66B** depicts a perspective view of an exemplary tenth expandable fusion device in an initial collapsed state.

[0203] **FIG. 66C** depicts a perspective view of an exemplary tenth expandable fusion device in a fully width expanded state.

[0204] **FIG. 66D** depicts a top perspective view of an exemplary tenth compound endplate, used in an exemplary expandable fusion device.

[0205] **FIG. 67A** depicts a perspective view of an exemplary eleventh expandable fusion device in a fully expanded state.

[0206] **FIG. 67B** depicts a perspective view of an exemplary eleventh endplate complex, used in an exemplary expandable fusion device.

[0207] **FIG. 67C** depicts a perspective view of an exemplary eleventh expandable fusion device of **FIG. 67A** in an initial collapsed state.

[0208] **FIG. 67D** depicts a perspective view of an exemplary eleventh expandable fusion device of **FIG. 67A** in a fully width expanded state.

[0209] **FIG. 68** depicts a perspective view of an exemplary twelfth expandable fusion device in an initial collapsed state.

[0210] **FIG. 69A** depicts a rear perspective view of an exemplary twelfth proximal wedge used in an exemplary expandable fusion device.

[0211] **FIG. 69B** depicts a section view of an exemplary twelfth proximal wedge used in an exemplary expandable fusion device.

[0212] **FIG. 70A** depicts a front view of an exemplary twelfth distal wedge used in an exemplary expandable fusion device.

[0213] **FIG. 70B** depicts a section view of an exemplary twelfth distal wedge used in an exemplary expandable fusion device.

[0214] **FIG. 71** depicts a perspective view of an exemplary twelfth expandable fusion device in an initial collapsed state and assembled with a tensioner instrument.

[0215] **FIG. 72A** Depicts a section view of an exemplary twelfth expandable fusion device in an initial collapsed state assembled with tensioner instrument.

[0216] **FIG. 72B** Depicts a section view of an exemplary twelfth expandable fusion device in an expanded state assembled with tensioner instrument.

[0217] **FIG. 72C** Depicts a section view of an exemplary twelfth expandable fusion device in an expanded state with tension member locked in place.

[0218] **FIG. 73A** depicts a top view of an exemplary thirteenth expandable fusion device in the initial collapsed state.

[0219] **FIG. 73B** depicts a top view of an exemplary thirteenth exemplary expandable fusion device in a fully width expanded state.

[0220] **FIG. 73C** depicts a perspective view an exemplary thirteenth expandable fusion device in the fully height expanded state.

[0221] **FIG. 73D** depicts an exploded view of an exemplary thirteenth expandable fusion device.

[0222] **FIG. 74A** depicts a perspective view of an exemplary thirteenth expandable fusion device attached to an exemplary inserter-expander instrument in the initial collapsed state.

[0223] **FIG. 74B** depicts a perspective view of an exemplary thirteenth expandable fusion device attached to an exemplary inserter-expander instrument in the fully width expanded state.

[0224] **FIG. 75A** depicts a top view of an exemplary fourteenth expandable fusion device in the initial collapsed state.

[0225] **FIG. 75B** depicts a top view of an exemplary fourteenth expandable fusion device in the fully width expanded state.

[0226] **FIG. 75C** depicts a perspective view of an exemplary fourteenth expandable fusion device in the fully height expanded state.

[0227] **FIG. 75D** depicts a perspective view of an exemplary fourteenth expandable fusion device in the fully width and height expanded state.

[0228] **FIG. 75E** depicts an exploded view of an exemplary fourteenth expandable fusion device.

[0229] **FIG. 76A** depicts a top view of an exemplary fifteenth expandable fusion device in the initial collapsed state.

[0230] **FIG. 76B** depicts a top view of an exemplary fifteenth expandable fusion device in the fully width expanded state.

[0231] **FIG. 76C** depicts a perspective view of an exemplary fifteenth expandable fusion device in a fully width and height expanded state.

[0232] **FIG. 76D** depicts an exploded view of an exemplary fifteenth expandable fusion device.

[0233] **FIG. 77A** depicts a perspective view of an exemplary fifteenth expandable fusion device attached to the inserter-expander instrument in the initial collapsed state.

[0234] **FIG. 77B** depicts a perspective view of an exemplary fifteenth expandable fusion device attached to the inserter-expander instrument in the fully width expanded state.

[0235] **FIG. 78** depicts a perspective view of an exemplary sixteenth expandable fusion device in the initial collapsed state.

[0236] **FIG. 79A** depicts a perspective view of an exemplary sixteenth expandable fusion device attached to the inserter-expander instrument in the initial collapsed state.

[0237] **FIG. 79B** depicts a perspective view of an exemplary sixteenth expandable fusion device attached to the inserter-expander instrument in the fully width expanded state.

[0238] **FIG. 80** depicts a top schematic view of an exemplary seventeenth expandable fusion device outlining its initial and width expanded configurations.

[0239] **FIG. 81A** depicts a perspective view of an exemplary eighteenth expandable fusion device in its expanded state.

[0240] **FIG. 81B** depicts a perspective view of an exemplary eighteenth expandable fusion device in its collapsed state.

[0241] **FIG. 81C** depicts a perspective view of an exemplary eighteenth expandable fusion device in an exploded state.

[0242] **FIG. 82** depicts a perspective view of an exemplary actuator of the eighteenth expandable fusion device.

[0243] **FIG. 83A** depicts a perspective view of an exemplary proximal wedge of the eighteenth expandable fusion device.

[0244] **FIG. 83B** depicts a perspective view of an exemplary distal wedge of the eighteenth expandable fusion device.

[0245] **FIG. 84A** depicts a first perspective view of an exemplary proximal ramp of the eighteenth expandable fusion device.

[0246] **FIG. 84B** depicts a second perspective view of an exemplary proximal ramp of the eighteenth expandable fusion device.

[0247] **FIG. 85** depicts a perspective view of an exemplary distal ramp of the eighteenth expandable fusion device.

[0248] **FIG. 86** depicts a perspective view of an exemplary endplate of the eighteenth expandable fusion device.

[0249] **FIG. 87A** depicts a perspective view of an exemplary nineteenth expandable fusion device in its expanded state.

[0250] **FIG. 87B** depicts a perspective view of an exemplary nineteenth expandable fusion device in its collapsed state.

[0251] **FIG. 87C** depicts a perspective view of an exemplary nineteenth expandable fusion device in an exploded state.

[0252] **FIG. 88** depicts a perspective view of an exemplary actuator of the nineteenth expandable fusion device.

[0253] **FIG. 89A** depicts a perspective view of an exemplary distal wedge of an exemplary nineteenth expandable fusion device.

[0254] **FIG. 89B** depicts a perspective view of an exemplary distal wedge of an exemplary nineteenth expandable fusion device.

[0255] **FIG. 90A** depicts a perspective view of an exemplary first ramp of an exemplary nineteenth expandable fusion device.

[0256] **FIG. 90B** depicts a perspective view of an exemplary first ramp of an exemplary nineteenth expandable fusion device.

[0257] **FIG. 91A** depicts a perspective view of an exemplary second ramp of an exemplary nineteenth expandable fusion device.

[0258] **FIG. 91B** depicts a perspective view of an exemplary second ramp of an exemplary nineteenth expandable fusion device.

[0259] **FIG. 92A** depicts a perspective view of an exemplary first endplate of an exemplary nineteenth expandable fusion device.

[0260] FIG. 92B depicts a perspective view of an exemplary first endplate of an exemplary nineteenth expandable fusion device.

[0261] FIG. 93A depicts a perspective view of an exemplary second endplate of an exemplary nineteenth expandable fusion device.

[0262] FIG. 93B depicts a perspective view of an exemplary second endplate of an exemplary nineteenth expandable fusion device.

[0263] FIG. 94A depicts a perspective view of an exemplary third endplate of an exemplary nineteenth expandable fusion device.

[0264] FIG. 94B depicts a perspective view of an exemplary third endplate of an exemplary nineteenth expandable fusion device.

[0265] FIG. 95A depicts a perspective view of an exemplary fourth endplate of an exemplary nineteenth expandable fusion device.

[0266] FIG. 95B depicts a perspective view of an exemplary fourth endplate of an exemplary nineteenth expandable fusion device.

[0267] FIG. 96A depicts a perspective view of an exemplary nineteenth expandable fusion device and an exemplary separated inserter tool.

[0268] FIG. 96B depicts a perspective view of an exemplary nineteenth expandable fusion device and an exemplary adjoined inserter tool.

[0269] FIG. 97 depicts a cross sectioned view of an exemplary nineteenth expandable fusion device and an exemplary adjoined inserter tool.

[0270] FIG. 98A depicts a perspective view of an exemplary twentieth expandable fusion device in its collapsed state.

[0271] FIG. 98B depicts a perspective view of an exemplary twentieth expandable fusion device in an exploded state.

[0272] FIG. 99 depicts a top view of an exemplary twenty-first expandable fusion device.

DETAILED DESCRIPTION

[0273] The following description of the various embodiments is merely exemplary in nature and is in no way intended to limit the teachings, their applications, or uses. While the following description is directed generally towards embodiments of the expandable fusion device and method for its implantation between two adjacent lumbar vertebrae using a lateral, posterior and transforaminal approaches to spine, it would be appreciated that similar mechanisms and arrangements of the same are also used in treatment of cervical, thoracic and sacral spine segments, utilizing other surgical approaches including but not limited to transpedicular, transiliac, anterior and anterior-lateral approaches and configured to interface with respective

anatomies and approach angles. Similarly, while the following description is directed generally towards embodiments of the expandable fusion device in which an actuator draws wedges together to cause expansion, it would be appreciated that in other embodiments the same functionality can easily be achieved through actuator forcing the wedges apart. A spinal fusion is typically employed to eliminate pain caused by the motion of degenerated disk material. Upon successful fusion, a fusion device becomes permanently fixed within the intervertebral disc space.

First Expandable Fusion Device

[0274] An exemplary embodiment of a first expandable fusion device **1000** is shown, per **FIG. 1**, in an initial collapsed state implanted between endplates **6** and **8** of adjacent vertebral bodies **2** and **4** through a surgical corridor **5**. Implanting the first expandable fusion device **1000** in the initial collapsed state reduces the impaction force and the size of the surgical corridor **5** required for implantation. Per **FIG. 2**, the first expandable fusion device **1000** is shown in an expanded state (expanded in both width and height) implanted between adjacent vertebral bodies **2** and **4** through the surgical corridor **5** and engaging the endplates **6** and **8**. The first expandable fusion device **1000** expands in height from about 8 mm to about 13 mm or more preferably from 8 mm to 16 mm or most preferably from 7 mm to 14 mm and in width from about 10 mm to about 18 mm and more preferably from about 11 mm to about 20 mm and more preferably from about 14 mm to about 24 mm or most preferably from about 15 mm to about 26 mm. The first expandable fusion device **1000** will preferably be longer than it is wide in its initial collapsed state and the endplates will preferably be longer than they are wide. Expanding the fusion device **1000** while implanted between the vertebral bodies **2** and **4** allows an increase in the width of the fusion device **1000** and the spacing or contact area (or foot-print) between the fusion device **1000** and the endplates **6** and **8** beyond that, which would otherwise be allowed by the surgical corridor **5** as well as application of distraction forces to the endplates **6** and **8** in order to preferably increase and maintain the distance and/or angle between the vertebral bodies **2** and **4**, by increasing and maintaining the height of the implant and/or the angular orientation of its components.

[0275] The components of the first expandable fusion device **1000** may be made out of a variety of materials including but not limited to metals and alloys (e. g. Commercially Pure Titanium, Titanium alloys including Ti-6Al-4V based alloys, Cobalt alloys including CoCrMo alloys, Stainless steel, Tantalum and its alloys, Platinum and its alloys, etc.), polymers (e. g. PEEK, PEKK, PEKEK, PEI, PET, PETG, UHMWPE, PPSU, Acetal, Polyacetal, etc. including carbon fiber reinforced varieties and other varieties filled, for example, with Carbon Fiber, Carbon

nano-tubes, Graphene, Barium Sulfate or Hydroxyapatite), ceramics (e. g. Aluminum Oxide, Zirconium oxide, Silicon nitride, diamond-like carbon, etc. as well as various metalized ceramics and metal-ceramic composites). Optionally, in any embodiment, the components of the fusion device **1000** are manufactured out of a Titanium alloy (including but not limited to Ti-6Al-4V alloys) or a Cobalt alloy including but not limited to CoCrMo alloys. Optionally, in any embodiment, manufacturing some of the threaded components of the fusion device **1000** out of a CoCr-based alloy allows for increased strength, reduced size, and other performance considerations.

[0276] Optionally, in any embodiment, bone allograft, bone autograft, xenograft, demineralized bone matrix product, synthetic bone substitute, bone morphogenic agents, or other bone growth inducing material are introduced within and/or around the fusion device **1000** to further promote and facilitate the intervertebral fusion. In one embodiment, the fusion device **1000** is preferably packed or injected with bone graft, demineralized bone matrix product, synthetic bone substitute, bone morphogenic agents, or other bone growth inducing material after it has been expanded, but in other embodiments, the graft material may also be introduced into the space within or around the fusion device **1000** prior to implantation or after the implantation but prior to expansion.

[0277] With reference to **FIGS. 3-5**, an exemplary fusion device **1000** is shown. **FIG. 3** shows the fully collapsed state of the fusion device **1000**. **FIG. 4** shows an expanded state of the fusion device **1000**. **FIG. 5** shows an exploded view of the fusion device **1000**. Optionally, in any embodiment, the fusion device **1000** includes a first endplate **100**, a second endplate **150**, a third endplate **200**, a fourth endplate **250**, a proximal wedge **550**, a distal wedge **650**, an actuator **500**, a first ramp **300**, a second ramp **350**, a third ramp **400**, a fourth ramp **450**, a retaining pin **600** (best seen in **Fig. 5**) and a retaining set screw **700**. Optionally, in any embodiment, the first endplate **100**, the second endplate **150**, the third endplate **200**, and the fourth endplate **250** are substantially identical, but although all four have the same set of features, the specific size and angular orientation of these features do not have to be identical in all embodiments or within any particular embodiment. Optionally, in any embodiment, the first ramp **300**, the second ramp **350**, the third ramp **400** and the fourth ramp **450** are substantially identical (it should be noted that the ramps, even while identical in an embodiment, may or need to be suitably rotated or mirrored to be assembled into arrangements shown in **FIGS. 3-5**), but although all four have the same set of features, the specific size and angular orientation of these features do not have to be identical in all embodiments or within any particular embodiment. Furthermore, the effects of the endplates, the ramps and the wedges having their ramped surfaces inclined at different angles on the expansion characteristics of the fusion device **1000** is illustrated in further detail below.

[0278] As will be discussed in more detail below, the actuator **500** functions, to pull the proximal wedge **550** and distal wedge **650** together forcing the first ramp **300** away from the third ramp **400** and also forcing the second ramp **350** away from the fourth ramp **450**, which causes the endplates **100** and **150** to be forced away from the endplates **250** and **200** (resulting in width expansion of the fusion device **1000**). Optionally, in any embodiment, only after the width expansion is substantially complete, the first ramp **300** and the second ramp **350** are pulled toward each other and the third ramp **400** and the fourth ramp **450** are pulled toward each other. The movement of the first ramp **300** and the second ramp **350** toward each other forces the first endplate **100** away from the second endplate **150** and the movement of the third ramp **400** toward the fourth ramp **450** forces the third endplate **200** away from the fourth endplate **250** (resulting in height expansion). The retaining pin **600** and the retaining set screw **700** act in an embodiment to resist the tension in the actuator **500** and maintaining the linear position of the proximal wedge **550** relative to the actuator **500**. Optionally, in any embodiment, a sub-assembly comprising the actuator, the proximal wedge, the distal wedge, and the four ramps are collectively referred to as the actuator assembly.

[0279] Optionally, in any embodiment, the ramps **300** and **350** and the ramps **400** and **450** only start moving toward each other after the width expansion has substantially taken place and the ramps **300** and **400** have substantially reached the limit of their travel relative to the proximal wedge **550** and the ramps **350** and **450** have substantially reached the limit of their travel relative to the distal wedge **650**. Optionally, in any embodiment, this delay in height expansion is achieved through the endplates **100**, **150**, **200**, **250** being slidably engaged with proximal wedge **550** and the distal wedge **650** through an initial portion of width expansion process. During the width expansion process, as the wedges **550** and **650** move toward each other, they eventually disengage from endplates **100**, **150**, **200**, **250** and allow them to expand in height as will be discussed below. Optionally, in any embodiment, the delay in height expansion is further accomplished by means of an inserter instrument constraining the height expansion until the width expansion has substantially taken place as will be discussed below.

[0280] When fully assembled, the first expandable fusion device **1000** is most preferably, a stable assembly of components that are all detained within the assembly throughout its full range of motion by means of “dove-tailed” articulations, the use of fasteners such as, for example, pins, balls, screws, and set screws. Optionally, in any embodiment, the fasteners are affixed in one component and travel in a mating feature (such as a track) of another component thereby limiting the range of motion of the first component to the amount permissible by the track feature thereby preventing the components from disassembly.

[0281] With reference to **FIGS. 6A-6F**, **FIGS. 6A** and **6B** show side and end views respectively of the fusion device **1000** in an initial fully collapsed state, **FIGS. 6C** and **6D** show side and end views respectively of the fusion device **1000** in a fully expanded width state and **FIGS. 6E** and **6F** show side and end views respectively of the fusion device **1000** in fully expanded width and height state.

[0282] **FIGS. 7A-7C** illustrate a mechanism for delaying the height expansion until width expansion is partially or substantially complete. In **FIG. 7A**, the fusion device **1000** is shown in an initial collapsed state and demonstrates, as an example, the engagement of the proximal wedge **550** with mating features of the endplates **100** and **150**, in this state, drawing the proximal wedge **550** and the distal wedge **650** together results in width expansion but not in height expansion of the fusion device **1000**. Optionally, in any embodiment, per **FIG. 7A**, the engagement between the proximal wedge and the endplates prevents height expansion. Once width expansion occurs to a sufficient extent for the wedges to disengage from the mating features on the endplates (shown in **FIG. 7B**), the further drawing of the proximal wedge **550** and the distal wedge **650** together may result in either height only expansion (shown in **FIG. 7C**) or in simultaneous height and width expansion. Optionally, in any embodiment, **FIG. 7B**, the disengagement of the proximal wedge from the endplates allows height expansion. Optionally, in any embodiment, starting width is preferably 14 mm and the height expansion starts when the width reaches about 20mm. Optionally, in any embodiment, the height expansion may start when full maximum or substantial (as discussed above) width is achieved. The delay in height expansion is achieved because in order for height expansion to take place, the pairs of ramps on either side of the fusion device **1000** have to translate toward each other relative to the endplates with which they are engaged. This cannot occur while the ramped surfaces of the wedges are simultaneously engaged with both the endplates and the ramps since the endplates are rigid and span the distance between the proximal wedge **550** and the distal wedge **650** and thereby only allow the width expansion until the state shown in **FIG. 3C** is reached, at which point the wedges are still engaged with the ramps but are no longer engaged with the endplates and drawing the wedges together from this point onward allows the ramps to move toward each other relative to the endplates resulting in height expansion. Detailed description of the components and their features is provided below.

[0283] Although the following discussion relates to the first endplate **100**, it should be understood that it also equally applies to the second endplate **150**, the third endplate **200** and the fourth endplate **250** as the first endplate **100** is substantially identical to the second endplate **150**, the third endplate **200** and the fourth endplate **250** in this embodiment (note that the endplates,

even while identical in an embodiment, may or need to be suitably rotated or mirrored to be assembled into arrangements shown above in the assemblies shown in **FIGS. 3-5**). The endplates **100** and **250** are collectively referred to as the upper endplate and the endplates **150** and **200** are collectively referred to as the lower endplate. It should also be understood that while the words “substantially identical” refer to the endplates **100**, **150**, **200** and **250** having the same or similar set of features, all of which features serving the same or similar function in each of the endplates **100**, **150**, **200** and **250** as described below, the specific size and angular orientation of these features may or may not be identical between the endplates **100**, **150**, **200** and **250** within any particular embodiment.

[0284] Turning now to **FIGS. 8A** and **8B** showing respectively the bottom and the top views of the endplate **100**. Optionally, in any embodiment, the first endplate **100** has a first end **102** and a second end **104**. In the illustrated embodiment, the first endplate **100** further comprises an upper surface **134** connecting the first end **102** and the second end **104**, and a lower surface **132** connecting the first end **102** and the second end **104**. Optionally, in any embodiment, the first endplate **100** further comprises two tapered slots, a first tapered slot **107** proximate the first end **102**, extending from the lower surface **132** toward the upper surface **134** and a second tapered slot **109** proximate the second end **104**, extending from the lower surface **132** toward the upper surface **134**. Optionally, in any embodiment, the slopes or shapes of the tapered slots **107** and **109** are equal or differ from each other.

[0285] The first tapered slot **107** comprises a bottom surface **106**, which is substantially parallel to the long axis in an embodiment, but may also be angled or curved in the plane transverse to the long axis in other embodiments, a tapered surface **110** generally transverse to the bottom surface **106** and a tapered surface **136** opposite of the tapered surface **110** and generally transverse to the bottom surface **106**, whereas the tapered surfaces **110** and **136** taper toward each other from bottom surface **106** and toward the inward surface **130**. The second tapered slot **109** comprises a bottom surface **108**, which is substantially parallel to the long axis in an embodiment, but may also be angled or curved in the plane transverse to the long axis in other embodiments, a tapered surface **138** generally transverse to the bottom surface **108** and a tapered surface **112** opposite of the tapered surface **138** and generally transverse to the bottom surface **108**, whereas the tapered surfaces **138** and **112** taper toward each other from bottom surface **108** and toward the inward surface **130**.

[0286] Endplate **100** further optionally comprises a first relief **125** forming a planar surface **126** and a second relief **127** forming a planar surface **128**. The first relief **125** extending from the first end **102** to the first tapered slot **107** and defined by the planar surface **126** substantially parallel

to the lower surface **132** and a first relief surface **114** substantially planar and parallel to the inward surface **130**. The second relief **127** extending from the second end **104** to the second tapered slot **109** and defined by a planar surface **128** substantially parallel to the lower surface **132** and a second relief surface **116** substantially planar and parallel to the inward surface **130**. Optionally, in any embodiment, the endplate **100** includes a first chamfer **142** proximate the first end **102** and the second chamfer **144** proximate the second end **104**. Chamfers **142** and **144** preferably facilitate introduction and removal of fusion device **1000** between the adjacent vertebral bodies **2** and **4** by reducing the height of the endplate **100** at first end **102** and the second end **104** thereby providing a tapered leading and trailing edges.

[0287] Optionally, in any embodiment, the endplate **100** further optionally comprises ramped grooves **122** and **118** proximate the first end **102** and ramped grooves **124** and **120** proximate the second end **104**. The ramped grooves **122**, **118** and **124**, **120** are configured to engage the mating ramped geometry of the proximal wedge **550** and the distal wedge **650** to cause the initial expansion of the fusion device **1000** to be limited to width expansion and to prevent the fusion device **1000** from expanding in width and height simultaneously. The slopes of the ramped grooves **122**, **118**, **124** and **120** are configured to match those of the wedges **550** and **650**. Ramped grooves **124** and **122** are configured to mate with the geometry of the trapezoidal (or in other embodiments T-shaped, Y-shaped, etc.) projections of the wedges **550** and **650**. The ramped grooves **118** and **120** are preferably each formed by two surfaces, one parallel to the bottom surface **132**, and one perpendicular to it. The ramped grooves **118** and **120** are configured to mate with the protuberances of the projections of the wedges **550** and **650**.

[0288] Turning now to **FIGS. 9A-9E**. It should be understood that although in the illustrative embodiment, the slots **107** and **109** have trapezoidal cross-sections, they can optionally have but are not limited to the following, T-shaped cross-section (shown in **FIG. 9A**), L-Shaped cross-section (shown in **FIG. 9B**), Y-shaped cross-section (shown in **FIG. 9C**), F-shaped cross-section (shown in **FIG. 9D**) or generally any cross-section that preferably results in the slots **107** and **109** being narrower at the inward surface **130** than they are at the bottom surfaces **106** and **108** or at any point in between the inward surface **130** and the bottom surfaces **106** and **108**. Optionally, in any embodiment, while the shapes described above are preferable when retention of the ramp **300** in the endplate **100** is desired by means of “dove-tailed”, tapered, T-shaped or otherwise slot geometry, a non-tapered, generally rectilinear cross-section (shown in **FIG. 9E**) of the slots **107** and **109** are beneficial for example when an additional fastener (e. g. pin or set screw) are used to retain the ramp **300** in the slots **107** or **109** to only allow translation in one dimension (while rotation in one or more planes may also be allowed). It should also be understood that although

the various alternative geometries of the endplates are presented here as discrete embodiments, these alternative embodiments have optional features which may be substituted or mixed/matched with any other embodiment in the specification. It should also be understood that substituting any of the aforementioned optional alternative features in the endplate component may or will necessitate the mating components (e. g. the endplates, the ramps and the wedges) to use the inverse or complementary geometry of those features for proper engagement and that the shape of that inverse or complementary geometry would follow inevitably from the optional alternative feature geometry described above.

[0289] FIGS. 10A-10D3 show alternative embodiments of the endplate 100. FIGS. 10A and 10B show an exemplary endplate 100 in which the lower surface 132 further includes a projection 145 sharing the tapered surface 110 with the first tapered slot 107 and a projection 146 sharing the tapered surface 112 with the second tapered slot 109. In the embodiment of FIGS. 10A and 10B, the lower surface 132 further includes a recess 147 configured to accept the projection 146 of another endplate and a recess 148 configured to accept the projection 145 of another endplate. The purpose of the projections 145 and 146 and the recesses 147 and 148 is to increase the contact area and provide additional stability between the endplates 100, 150, 200, 250 and the ramps 300, 350, 400, 450 when the fusion device 1000 approaches maximum height expansion state (shown in FIG. 10C below). In embodiments without the projections 145 and 146, as the fusion device 1000 expands in height, the contact area between the endplates and the ramps steadily decreases as the ramps translate through the tapered slots of the endplates to produce expansion. The projections 145 and 146 compensate for this loss of contact area thereby improving the stability of the fusion device 1000 assembly. It should be understood that the same embodiments discussed above and shown in to FIGS. 9A, 9B, 9C, 9D would equally apply to the embodiments shown in FIGS. 10A and 10B. Optionally, in any embodiment, some of the areas where the projections 145 and 146 generate additional contact area between the endplates and the ramps. Furthermore, Optionally, in any embodiment, the projections 145 and 146 and the mating recesses 147 and 148 though pictured as generally triangular in an embodiment, may have other shapes that accomplish the same goal of increasing the contact area between the endplates 100, 150, 200, 250 and the ramps 300, 350, 400, 450 as the fusion device 1000 approaches maximum height expansion state. FIG. 10C shows a fully expanded state of an exemplary fusion device 1000 that includes the projections 145 and 146 as well as the mating recesses 147 and 148 on the endplates. Some of the areas where the projections generate additional contact area between the endplates and the ramps are indicated and labeled. FIGS. 10D1-10D3 show an exemplary fusion device 1000 in which the endplate 100 includes a

protrusion **143** on its proximal end. The protrusion **143** further includes an aperture **149** configured to accept a bone fastener **730**. The angle between the central axis of the aperture **149** and the long axis of the endplate **100** may have any value between 0 and 90 degrees but most preferably between 0 and 45 degrees and generally (but not necessarily in embodiments where the proximal portion of the bone fastener **730** (i. e. the “head” of the fastener **730**) in contact with the protrusion **143** is substantially greater than that of the main body of the bone fastener **730** contacting bone (i. e. the shank of the fastener **730**) and where the main body is substantially smaller than the aperture **149**) defines the trajectory of the bone fastener **730**, shown assembled with the fusion device **1000** in **FIG. 10D3**. It should be understood that although the various alternative geometries of the endplates are presented here as discrete embodiments, these alternative embodiments have optional features which may be substituted or mixed/matched with any other embodiment in the specification. It should also be understood that substituting any of the aforementioned optional alternative features in the endplate component may or will necessitate the mating components (e. g. the endplates, the ramps and the wedges) to use the inverse or complementary geometry of and to those features for proper engagement and that the shape of that inverse or complementary geometry would follow inevitably from the optional alternative feature geometry described above.

[0290] As illustrated in **FIGS. 11A-12D**, Optionally, in any embodiment, per **FIGS. 11A, 11D, and 12A**, the upper surface **134** of the first endplate **100** is generally planar to allow the upper surface **134** of the first endplate **100** to engage with the adjacent vertebral body **2**. Alternatively, the upper surface **134** are curved in one or more planes (shown in **FIGS. 11B, 11C, 11F, 11H, and 12B**) to allow for a greater degree of engagement with the adjacent vertebral body **2**.

Optionally, in any embodiment, the upper surface **134** are generally planar but include a generally straight ramped surface (shown in **FIGS. 11G and 12C**) or a curved ramped surface (shown in **FIGS. 11E, 11I and 12D**). The ramped surface allows for engagement with the adjacent vertebral body **2** in a lordotic fashion as shown for example in **FIGS. 11E** and/or for example in a coronally tapered fashion as shown for example in **FIGS. 12C and 12D**.

Optionally, in any embodiment, an arrangement of non-ramped endplates of different heights as well as ramped and non-ramped endplates of different heights also results in a geometry suitable for lordotic engagement with the endplates, which are seen illustrated in **FIGS. 11D, 11F, 11H, and 11I**). It should be understood that since the **FIGS. 11A-11I** and **FIGS. 12A-12D** show the device **1000** in two different projections 90 degrees from each other, the ramped quality of the surface **134** is described as “lordotic” for **FIGS. 11A-11I** and as “tapered” for **FIGS. 12A-12D**. It is further contemplated that although in one embodiment, all endplates in the fusion device

1000 have the same length, in other embodiments, some or all of the endplates may have different lengths to better accommodate the target anatomy. **FIGS. 13A** and **13C** show a fully collapsed and fully expanded views of an exemplary fusion device **1000** in which all endplates have the same length and **FIGS. 13B** and **13D** show an exemplary fusion device **1000** in which two of the endplates have shorter length than the other two, which is seen as advantageous in lateral approach applications as well as in some posterior approach applications. Optionally, in any embodiment, the upper surface **134** includes texturing **140** to aid in gripping the adjacent vertebral bodies. Although In the illustrated embodiment, the texturing **140** comprises series of parallel grooves running transversely to the long axis of the endplate **100**, including but is not limited to the following, the texturing includes teeth, ridges, areas of high surface roughness, metallic or ceramic coatings with relatively high surface roughness, friction increasing elements, keels, spikes, or gripping or purchasing projections. Optionally, in any embodiment, one or more of the endplates are shorter, longer, narrower, or wider than others. It should be understood that although the various alternative geometries of the endplates are presented here as discrete embodiments, these alternative embodiments have optional features which may be substituted or mixed/matched with any other embodiment in the specification. It should also be understood that substituting any of the aforementioned optional alternative features in the endplate component may or will necessitate the mating components (e. g. the endplates, the ramps and the wedges) to use the inverse and/or complementary geometry of/to those features for proper contemplated engagement between the various components of the fusion device **1000** and between those components and the surrounding anatomy and that the shape of that inverse and/or complementary geometry would follow inevitably from the optional alternative feature geometry described above.

[0291] The effect of varying the slopes and/or the orientations of the tapered slots **107** and **109** or the amount of travel allowed between the ramps and the tapered slots **107** and **109** are seen illustrated in **FIGS. 14A-14B2**. **FIG. 14A** shows the effects of varying the slopes and/or the orientation of the slots **107** and **109** on each of the four endplates viewed from the side where the top of the device **1000** is represented by the endplate **250** and the bottom of the device is represented by the endplate **200**. Varying the slopes of the slots **107** and **109** or limiting the allowable travel between the ramps and the slots **107** and **109** within each of the endplates may result, but is not limited to the first ends **102** and the second ends **104** expanding evenly on both top and bottom of the fusion device **1000**, expanding unevenly on both top and bottom, expanding evenly on top and unevenly on bottom or expanding evenly on bottom and unevenly on top of the fusion device **1000**. **FIGS. 14B1** and **14B2** show a respectively the initial fully

collapsed and an expanded view of an exemplary fusion device **1000** configured to expand unevenly at its proximal and distal ends, leading to an expanded state in which the endplates are tapering at an angle. The embodiment of **FIGS. 14B1** and **14B2** employs an alternative embodiment of the ramp **300** (discussed in detail below) suitable for uneven expansion between one end of the endplate and the other end of the endplate by means of allowing the tapered slots **107** and **109** to make contact with circular surfaces instead of the flat ramped surfaces of other embodiments, which in turn allows the long axes of the endplates to be at an angle to the long axes of the ramps. The embodiment of **FIGS. 14B1** and **14B2** further employs a mechanism, described in detail below, which independently limits the amount of travel between the ramp and the tapered slot **107** and the ramp and the tapered slot **109**, which allows, for example, the proximal end of the endplate to reach the end of its height expansion and therefore stop expanding before the distal end of the endplate does, resulting in the distal end of the endplate continuing expanding after the proximal end has stopped expanding thereby achieving greater height expansion than the proximal end at the fully expanded state.

[0292] Turning now to **FIGS. 15A-15G**, the effects of varying the slope and/or orientation of the ramped grooves **122**, **118**, **124** and **120** of the endplate **100** as well as the slopes and/or orientations of the complementary mating features of the ramps and the wedges are shown. **FIG. 15A** shows an end view of the fusion device **1000**, where the top of the device **1000** is represented by the endplates **100** and **250** and the bottom of the device is represented by the endplates **150** and **200**. **FIG. 15A** shows an embodiment in which both sides of the fusion device **1000** expand evenly and an embodiment in which left and right sides expand unevenly. **FIGS. 15B**, **15C** and **15D** show an exemplary fusion device **1000** in which the left and right sides of the fusion device **1000** expand unevenly due to the variation of the slopes of the mating ramped features of the endplates, the wedges and the ramps. **FIG. 15B** shows the top view of the collapsed state of the embodiment, **FIG. 15C** shows the top view of the expanded state of the embodiment and schematically indicates the amounts of width expansion achieved in each direction, which are unequal. **FIG. 15D** shows a perspective view of the expanded state of the embodiment and allows a better view of the difference in the slopes of the ramped surfaces between the two sides of the fusion device **1000**. **FIG. 15E** further shows an exemplary distal wedge **650** used in the assembly **1000** shown in **FIG. 15D**. **FIG. 15F** further shows an exemplary proximal wedge **550** used in the assembly **1000** shown in **FIG. 15D**. **FIG. 15G** further shows an exemplary ramp **300** used in the assembly **1000** shown in **FIG. 15D**. Turning now to **FIG. 16**, which shows the end views of four embodiments of the fusion device **1000** illustrating the effects of varying the slopes of the slots **107** and **109** between the endplates but

keeping them the same within each individual endplate, which may result but is not limited to all four endplates expanding at the same rate, all four endplates expanding at different rates, any three endplates expanding at the same rate, while the fourth expands at a different rate, any two endplates expanding at one rate, while the other two expand at a different rate. Furthermore, curving the slots **107** and **109** in the plane transverse to the long axis of any of the endplates will preferably cause those endplates to tilt during expansion as shown in **FIG. 16**. It should be understood that although the various alternative geometries of the endplates, the wedges, and the ramps are presented here as discrete embodiments, these alternative embodiments have optional features which may be substituted or mixed/matched with any other embodiment in the specification. It should also be understood that substituting any of the aforementioned optional alternative features in one component may or will necessitate the mating components (e. g. the endplates, the ramps and/or the wedges) to use the inverse and/or complementary geometry of those features for proper contemplated engagement between all of the various components of the fusion device **1000** and between those components and the surrounding anatomy and that the shape of that inverse and/or complementary geometry would follow inevitably from the optional alternative feature geometry described above.

[0293] Although the following discussion relates to the first ramp **300**, it should be understood that it also equally applies to the second ramp **350**, the third ramp **400** and the fourth ramp **450** as the first ramp **300** is substantially identical to the second ramp **350**, the third ramp **400** and the fourth ramp **450** in embodiments of the present disclosure (note that the ramps, even while identical in an embodiment, may or need to be suitably rotated to be assembled into arrangements shown above in the assemblies shown in **FIGS. 3-5**). It should also be understood that while the words “substantially identical” refer to the ramps **300**, **350**, **400** and **450** having the same set of features, all of which features serving the same or similar function in each of the ramps **100**, **150**, **200** and **250** as described below, the specific size and angular orientation of these features may or may not be identical between the ramps **300**, **350**, **400** and **450** within any particular embodiment.

[0294] Turning now to **FIGS. 17A** and **17B**, in an embodiment, the first ramp **300** has a first end **301** and a second end **303**. In the illustrated embodiment, the first ramp **300** further comprises an inner surface **305** connecting the first end **301** and the second end **303**, and an outer surface **307** (best seen in **Fig. 17B**) connecting the first end **301** and the second end **303**. The first ramp **300** further comprises an upper surface **309** connecting the first end **301** and the second end **303**, and a lower surface **311** connecting the first end **301** and the second end **303**, the two surfaces **309** and **311** being preferably but not necessarily parallel to each other. The first ramp **300** further

comprises a protuberance **315** further comprising an upper branch **321** extending preferably but not necessarily past the outer surface **307** and the lower surface **311**, and a lower branch **323** extending preferably but not necessarily past the outer surface **307** and the lower surface **311**. The upper branch **321** comprises a first ramped surface **302** and a second ramped surface **310**, which extend from the inner surface **305** and taper outward in the direction of outer surface **327**, giving the upper branch **321** a generally trapezoidal cross-section. The lower branch **323** comprises a first ramped surface **304** and a second ramped surface **312** which extend from the inner surface **305** and taper outward in the direction of the outer surface **327**, giving the lower branch **323** a generally trapezoidal cross-section. The branches **321** and **323** are contemplated to slidably engage the tapered slots **107** and **109** in the end plates. The mating cross-sections of the branches **321** and **323** and the tapered slots **107** and **109** are contemplated to be configured to only allow translation in one dimension, either in a straight or a curved line (though some embodiments may allow rotation in one or more planes).

[0295] As a rest be seen in FIG. 17A, the inner surface **305** includes a projection **319** forming a ramped surface **320** and a surface **325** that preferably form angles greater than 90 degrees with the inner surface **305**, as FIG. 17A shows. The projection **319** includes a first branch **314** and a second branch **316** and a groove **322**. The groove **322** extends from the outer surface **307**, along the ramped surface **320** and toward the inner surface **305**. The groove **322** does not extend through the surface **325** instead terminating in a surface **324**. As will be discussed below, the purpose of the channel **322** and the surface **324** is to limit the motion of the proximal wedge **550** and the distal wedge **650** with respect to the ramp **300** by causing a mating feature on the ramp **300** to bottom out on the surface **324**. The channel **322** may further include a blind bore **308** which is coincident with the surface **324**. The purpose of the bore **308** is to optionally accept a mating pin to limit the amount of width expansion allowable. The branch **314** extends from the ramped surface **320** to a surface **329** and the branch **316** extends from the ramped surface **320** to a surface **330**. The projection **319** further includes a relief **306** whose axis is substantially parallel to the long axis. The relief **306** is configured to mate with the actuator **500** and allow the ramps to be in closer proximity to each other than would otherwise be possible without the relief **306**. The relief **306** has any cross-section suitable to accomplish the function described above, for example a generally rectilinear cross-section or more preferably a partially polygonal cross-section or most preferably a circular cross-section. The ramped surface **320** and the branches **314** and **316** form a tapered channel **328**, which has a generally trapezoidal cross-section. It should be understood that although in the illustrative embodiment, the tapered channel **328** has a trapezoidal cross-section, the cross section may comprise, is not limited to, a T-shaped cross-

section (shown in **FIG. 18C**), a Y-Shaped cross-section (shown in **FIGS. 18D** and **18E**), an L-shaped cross-section (not shown), an F-shaped cross-section (not shown) or generally any cross-section that preferably results in the tapered channel **328** being narrower at a surface **329** than it is at the ramped surface **320** or at any point in between the surface **329** and the ramped surface **327**. Optionally, in any embodiment, the slope of the ramped surface **320** may or may not be the same between the ramps **350**, **400**, **450**, **500** in the end plates.

[0296] It should be understood that although in the illustrative embodiment, the branches **321** and **323** have trapezoidal cross-section, they can have but are not limited to the following, T-shaped cross-section, Y-Shaped cross-section, L-shaped cross-section or generally any cross-section that preferably results in the branches **321** and **323** being narrower at the inner surface **305** than they are at the outer surface **327** or at any point in between the inner surface **305** and the outer surface **327**. **FIGS. 18A, 18B, 18C, 18D, 18E** show a number of cross-sections that the branches **321** and **323** may take. Any embodiment described herein may optionally have these cross-sections in their branches. L-shaped (**FIG. 18A**), U-shaped (**FIG. 18B**) and T-shaped (**FIG. 18C**) cross-sections may be particularly preferable due to manufacturability considerations, but the Y-shaped cross-section (**FIG. 18D**) and an “Inside-T” shaped cross-section (**FIG. 18E**) are also possible. Optionally, in any embodiment, the slopes of the branches **321** and **323** are equal or differ from each other. Since the branches **321** and **323** are intended to mate with slots **107** and **109**, the effects of varying their slopes is the same as discussed above for the slots **107** and **109** in the endplate **100**. Likewise, the effects of varying the slope of the ramped surface **320** between each of the four ramps on the expansion characteristics of the device **1000** has been described above and are seen above in **FIGS. 15A-15G**, but to add to the description of these figures and in light of the detailed description of the ramp **300** specification provided here, it should be mentioned that since the slope of the ramped surface **320** controls the width expansion of the device **1000**, varying its slope in each of the ramps (as well as varying the mating slopes of the ramps in the wedges in complementary fashion) may result in but is not limited to all four endplates expanding at the same rate, the endplates on the right side expanding faster than the endplates on the left side and the endplates on the left side expanding faster than the endplates on the right side or one, some or all of the endplates expanding faster than the others. It should be understood that although the various alternative geometries of the ramps may be presented here as discrete embodiments, these alternative embodiments have optional features which may be substituted or mixed/matched with any other embodiment in the specification. It should also be understood that substituting any of the aforementioned optional alternative features in the ramp component will necessitate the mating components (e. g. the endplates, the

wedges and/or the actuator) to use the inverse or complementary geometry of those features for proper engagement and that the shape of that inverse or complementary geometry would follow inevitably from the optional alternative feature geometry described above.

[0297] Turning now to **FIGS. 19A-19H2**, where the **FIGS. 19A** and **19B** show an alternative embodiment of the ramp **300** in which the branches **321** and **323** comprise generally cylindrical (in other contemplated embodiments – conical) protrusions **331** and **332** respectively with their central axes generally perpendicular to the long axis of the ramp **300**. Optionally, in any embodiment, the protrusions **331** and **332** further include apertures **334** and **335** respectively. The apertures **334** and **335** have their central axes coincident with the central axes of the protrusions **331** and **332** and said apertures are configured to engage a fastener **740**, which in an embodiment is a pin (but in other embodiments is a screw) configured to engage the apertures **334** and **335** as well as a track **127A** (best seen in **FIG. 19H2**) extending into the bottom surface **108** of the endplate **100** and a corresponding track (not shown) extending into the bottom surface **106** of the endplate **100**. The fasteners **740** when engaged into the corresponding tracks in the endplate **100** are intended to equally or preferentially limit the amount of translation allowed between the ramp **300** and the ramped slots **107** and **109** in the endplate **100**. It should be understood that although in the illustrative embodiment, the protrusions **331** and **332** have generally rectangular cross-sections through their central axes, or cross sections including but not limited to, L-shaped cross-section (shown in **FIGS. 19C** and **19D**), T-Shaped cross-section (shown in **FIGS. 19E** and **19F**), trapezoidal cross-section (not shown) or generally any cross-section that preferably results in the protrusions **331** and **332** being narrower at the inner surface **305** than they are at the outer surface **327** or at any point in between the inner surface **305** and the outer surface **327**. The articulation between these embodiments of the ramp **300** and the endplate **100** is intended to allow the ramp **300** to translate in the ramped slots **107** and/or **109** of the endplate **100** in only one dimension and to rotate within said slots in only one plane.

[0298] **FIGS. 19G1-19G3** show section views of the assembly of an embodiment of articulation of an exemplary endplate **100** and an exemplary ramp **300** in which the ramp **300** is translationally limited within the ramped slot of the endplate **100** at one angle formed between the long axes of the ramp **300** and the endplate **100** while being allowed to pass (for example and preferably during assembly of the fusion device **1000**) at another angle (preferably outside the functional and/or useful range of an exemplary fusion device **1000**) between the long axes of the ramp **300** and the endplate **100** due to a T-slot **149** being a blind slot and not breaking through the bottom surface **132** of the endplate **100**. **FIGS. 19H1** and **19H2** show a portion of an exemplary fusion device **1000** including an embodiment of articulation between the ramp **300**

and the endplate **100** in which the ramped slot **109** of the endplate **100** has a generally T-shaped cross-section and in which the protrusion **331** of the ramp **300** has a generally T-shaped cross-section. The protrusion **331** further includes the aperture **334** generally concentric with it, where the aperture **334** is configured to accept the fastener **740**, which in this embodiment comprises a pin. The ramped slot **107** of the endplate **100** further comprises a track recessed into its bottom surface and configured to engage the fastener **740** with the purpose of limiting the translational travel of the ramp **300** inside the slot **107** of the endplate **100**. **FIG. 19H1** shows the side view of the assembled articulation and **FIG. 19H2** shows the exploded view of the articulation. Both the embodiments of **FIGS. 19G1-19G3** and **FIGS. 19H1-19H2** are contemplated as useful for, but not limited to, producing uneven expansion of the distal and proximal ends of the fusion device **1000** shown in **FIGS. 14B1** and **14B2** above. It should be understood that although the various alternative geometries of the ramps are presented here as discrete embodiments, these alternative embodiments have optional features which may be substituted or mixed/matched with any other embodiments in the specification. It should also be understood that substituting any of the aforementioned optional alternative features in one component may or will necessitate the mating components (e. g. the endplates, the wedges and/or the actuator) to use the inverse and/or complementary geometry of those features for proper intended engagement between both the various components of the fusion device **1000** and between those components and the surrounding anatomy and that the shape of that inverse and/or complementary geometry would follow inevitably from the optional alternative feature geometries described above.

[0299] Turning now to **FIG. 20**. The actuator **500** comprises a proximal end **504**, a distal end **502**, and a cylindrical surface **506** connecting the proximal end **504** and the distal end **502**. Optionally, in any embodiment, the actuator **500** further comprises a drive feature **512** proximate the proximal end **504** and a thread **508** proximate the distal end **502**. The cylindrical surface **506** includes a groove **514** circumferentially disposed around the actuator proximate the drive feature **512** and a ridge **510** circumferentially disposed around the actuator proximate the thread **508**. The ridge **510** is contemplated to serve as a depth stop to limit the linear travel of the actuator **500** by making contact with the distal wedge **650** at the end of allowable travel range. Although in an embodiment, the drive feature **512** is shown as an hexalobular protrusion (external hexalobe drive), Optionally, in any embodiment, the drive feature **512** may be but is not limited to internal hexalobe, external hexagon, internal hexagon, external cruciform, internal cruciform or any other shape. Optionally, in any embodiment shown in **FIG. 21A**, the drive feature **512** is a hexagonal recess (internal hexagon drive). Additionally, in the embodiment shown in **FIG. 21A**, the cylindrical surface **506** of the actuator **500** further includes a ridge **515** circumferentially

disposed around the actuator proximate the proximal end **504**, but distal to the groove **514**. The ridge **515** is configured to bottom out on the second end **560** of the proximal wedge **550** and is contemplated to provide resistance to the actuator **500** pushing through the central aperture **568** and subjecting the retaining pin **600**, the retaining set screw **700**, a retaining c-clip **720** or some other actuator retention means to high loads. **FIG. 25** shows a section view of a sub-assembly including the proximal wedge **550**, the actuator **500**, and the retaining c-clip **720** and demonstrates the location and function of the ridge **515**. Optionally, in any embodiment shown in **FIG. 21B**, the actuator **500** comprises an additional thread **517** proximate the proximal end **504**. The thread **517** is comprised of a helical groove of opposite direction to that of the thread **508** (i. e. if the thread **508** is right-handed, then the thread **517** is left-handed). The effect of addition of the opposing direction thread **517** is that the actuator **500** would thread into the distal wedge **650** in a for example clock-wise fashion while threading into the proximal wedge **550** in, for example, a counter-clock-wise fashion, which causes the actuator **500** to draw the wedges together while also translating relative to both wedges when torsionally actuated. The extent of travel of the actuator **500** relative to each of the wedges is contemplated as being controlled either by means of thread lengths in which case the run-out of the threads would bottom out on the respective wedges or by means of dedicated ridges (e. g. **510** and **515**) circumferentially disposed around the actuator and configured to bottom out on the respective wedges thereby limiting translation of the actuator. It should be understood that although the various alternative geometries of the actuators are presented here as discrete embodiments, these alternative embodiments have optional features which may be substituted or mixed/matched with any other embodiment in the specification. It should also be understood that substituting any of the aforementioned optional alternative features in the actuator component will necessitate the mating components (such as the wedges, the ramps or any auxiliary instrumentation intended to engage the actuator **500**) to use the inverse or complementary geometry of those features for proper engagement and that the shape of that inverse geometry would follow inevitably from the optional alternative feature geometry described above.

[0300] With respect to **FIG. 22**, the retaining pin **600** comprises a first end **604**, a second end **602**, and a cylindrical surface **606** connecting the ends **604** and **602**, whereas the cylindrical surface **606** may have any diameter and any length suitable for a particular application, mating feature or component. With respect to **FIG. 23**, the retaining set screw **700** comprises a first end **704**, a second end **702**, and a threaded surface **705** connecting the ends **704** and **702**. The retaining set screw **700** further comprises a drive feature proximate the first end **704** and a cylindrical protrusion **710** extending from the second end **702**. With respect to **FIG. 24**, the

retaining c-clip 720 comprises an inner diameter 724, an outer diameter 722, and a split 725 interrupting both the inner diameter 722 and the outer diameter 724.

[0301] Referring further to FIGS. 26A-26B, in an exemplary embodiment, the proximal wedge 550 comprises a first end 562, a second end 560, an upper surface 590 connecting the first end 562 and the second end 560, and a lower surface 552 connecting the first end 562 and the second end 560. The proximal wedge further comprises a first ramped surface 580 and a second ramped surface 582 located proximate the second end 560. The first ramped surface 580 includes a first projection 564 extending from the first ramped surface 580 towards a surface 565 and having a generally trapezoidal cross-section. The second ramped surface 582 includes a second projection 566 extending from the second ramped surface 582 toward a surface 567 and having a generally trapezoidal cross-section. Optionally, in any embodiment, the first projection 564 includes a protuberance 574 and the second projection 566 includes a protuberance 575. The projections 564 and 566 are contemplated to be configured to slidably engage the tapered channel 328 of the ramp 300 in the endplates in such a way that the ramp 300 only translates relative to the proximal wedge 550 in one dimension – back and forth in either in a straight or a curved line (Optionally, in any embodiment, rotation in one plane may also be allowed between the ramps and the wedge 550). Optionally, in any embodiment, the protuberances 574 and 575 are configured to engage the groove 322 on the ramp 300 in the endplates and limit the extent of translation between the ramp 300 and the wedge 550 by making contact with the surface 324 at the limit of allowable travel. Optionally, in any embodiment, the upper surface 590 further includes a projection 554 extending from the upper surface 590. The projection 554 includes a channel 599 extending through the first end 562 but not through the second end 560. It should be understood that the channel 599 is intended as a mating feature for auxiliary instrumentation used in introduction, expansion of the device 1000 and/or graft delivery into the device 1000 and may be configured, shaped and located in other ways so long as it is accessible from the first end 562. The proximal wedge 550 further comprises a central aperture 568 (e. g. as shown in Fig. 19), and side apertures 570 and 572 (e. g. as shown in Fig. 26B). Optionally, in any embodiment, the central aperture 568 includes an undercut 571 and both of the side-apertures 570 and 572 are threaded. The central aperture 568 is configured to engage and retain the actuator 500 by means of the retaining set screw 700 engaged in a threaded hole 586 and extending into the groove 514 of the actuator 500 and/or the retaining pin 600 engaged in a bore 584 and extending into the groove 514 of the actuator 500 or the retaining c-clip 720 (see FIG. 24) engaged simultaneously in the undercut 571 and the groove 514 of the actuator 500 (shown in FIG. 25) or any other retaining mechanism allowing the actuator 500 to rotate inside the central aperture 568, but

substantially preventing the actuator **500** from translating along the axis of the central aperture **568**.

[0302] It should be understood that although in the illustrative embodiment, the first projection **564** and the second projection **566** have trapezoidal cross-sections, or a cross section including but not limited to T-shaped cross-section, Y-Shaped cross-section (not shown), or generally any cross-section that preferably results in the projections **564** and **566** being narrower at the ramped surfaces **580** and **582** than they are at the surfaces **565** and **567**. Similarly, any embodiment may optionally have the cross-sections described above. **FIG. 27A** shows an embodiment with the projections **564** and **566** having T-shaped cross-sections, which may be particularly preferable due to manufacturability and performance considerations.

[0303] Side apertures **570** and **572** are intended as a mating features for auxiliary instrumentation used in introduction and/or expansion of the device **1000** and/or graft delivery into the device **1000** and may be configured, shaped and located in other ways so long as they are accessible from the first end **562**. As an example, there may be one or two side apertures, one, both or none of the side apertures may be threaded, one or both of the side apertures may be non-circular. Additionally, the central aperture **568** is intended to mate with the actuator and may or may not be in the geometric center of the proximal wedge **550**, and may or may not be threaded. As an example, **FIG. 27B** shows an exemplary proximal wedge **550** in which the central aperture is threaded with a left-handed thread (but may in other embodiments be threaded with a right-handed thread), one of the side apertures is threaded and one of the side apertures has a generally rectangular or preferably, a generally square shape, which is seen as advantageous for graft delivery into the fusion device **1000** because it may provide a greater cross-sectional area for graft material to travel through as compared to a circular opening of similar external dimensions. Other optional instrument attachment features are also contemplated including but not limited to embodiments of the proximal wedge **550** shown in **FIGS. 27B, 27C, and 27D**. For example, an embodiment shown in **FIG. 27B** does not include the projection **554** and instead includes a projection **587** and a projection **588** extending from the upper surface and forming a channel **591** and a projection **589** and a projection **590** extending from the lower surface **552** and forming a channel **592**. **FIG. 27C** shows the embodiment from **FIG. 27B** which includes a groove **592** extending from the projection **587** to the projection **589**. Optionally, in any embodiment, another groove (not shown) of similar dimensions may extend from the projection **589** to the projection **590**. It is further contemplated that these grooves would serve as engagement features for auxiliary instrumentation. The embodiment of **FIG. 27C** further includes both side apertures being circular and threaded and the central aperture being

unthreaded. **FIG. 27D** shows the embodiment from **FIG. 27C** which further includes stepped recesses **593** and **594** on the sides of the proximal wedge **550** with the deeper portions of the stepped recesses **593** and **594** located proximate the second end **560**. Optionally, in any embodiment, the stepped recesses **593** and **594** would serve as engagement features for auxiliary instrumentation. The embodiment of **FIG. 27D** further includes one of the side apertures being circular and threaded, one aperture being generally rectangular or preferably, generally square in shape and the central aperture being unthreaded. Auxiliary instrumentation is discussed in detail below. Optionally, in any embodiment, the slopes of the ramped surfaces **580** and **582** (and the slopes of the ramped surfaces **680** and **682** discussed below) are equal or differ from each other. Since the branches of the ramped surfaces **580**, **582** (as well as **680**, **682** discussed below) of the wedges are intended to mate with the ramped surfaces **320** of the ramps **300**, **350**, **400**, **450**, the effects of varying their slopes is the same as discussed above for the ramped surfaces **320** in the ramp **300**. It should be understood that although the various alternative geometries of the proximal wedges are presented here as discrete embodiments, these alternative embodiments have optional features which may be substituted or mixed/matched with any other embodiment in the specification. It should also be understood that substituting any of the aforementioned optional alternative features in the proximal wedge component will necessitate the mating components (e. g. the endplates, the ramps, the actuator and the distal wedge) to use the inverse or complementary geometry to those features for proper engagement and that the shape of that inverse geometry would follow inevitably from the optional alternative feature geometry described above.

[0304] Turning now to **FIGS. 28A** and **28B**, in an exemplary embodiment, the distal wedge **650** comprises a first end **662**, a second end **660**, an upper surface **690** connecting the first end **662** and the second end **660**, and a lower surface **652** connecting the first end **662** and the second end **660**. The proximal wedge further comprises a planar first ramped surface **680** and a planar second ramped surface **682** located proximate the second end **660**. The first ramped surface **680** includes a first projection **664** extending from the first ramped surface **680** toward a surface **665** and having a generally trapezoidal cross-section. The second ramped surface **682** includes a second projection **666** extending from the second ramped surface **682** toward a surface **667** and having a generally trapezoidal cross-section. Optionally, in any embodiment, the first projection **664** includes a protuberance **674** and the second projection **666** includes a protuberance **675**. The projections **664** and **666** are contemplated to be configured to slidably engage the tapered channel **328** of the ramp **300** in the end plates in such a way that the ramp **300** only translates relative to the proximal wedge **650** in one dimension – back and forth in either in a straight or a

curved line. Optionally, in any embodiment, the protuberances **674** and **675** are configured to engage the groove **322** on the ramp **300** and limit the extent of translation between the ramp **300** and the wedge **650** by making contact with the surface **324** at the limit of allowable travel. Optionally, in any embodiment, in an embodiment, the upper surface **690** further includes a projection **654** extending from the upper surface **690** and a projection **655** extending from the lower surface **652**. The projections **654** and **655** further include chamfers **688** and **689** configured to facilitate introduction of the device **1000** between and initial distraction of the adjacent vertebrae **2** and **4**. The distal wedge **650** further comprises a central aperture **668**, and side apertures **670** and **672**. The central aperture **668** is fully threaded and both of the side-apertures **670** and **672** are threaded. The central aperture **668** is configured to engage the actuator **500**. Side apertures are intended as a mating features for auxiliary instrumentation used in introduction and/or expansion of the device **1000** and/or graft delivery into the device **1000** and may be configured, shaped and located in other ways. Optionally, in any embodiment, there may be one or two side apertures, one, both or none of the side apertures **670** and **672** may be threaded and one or both of the side apertures **670** and **672** may be non-circular. **FIG. 29A** shows, as an example, an exemplary distal wedge **650** which does not include the side apertures. It should be understood that although in the illustrative embodiment, the first projection **664** and the second projection **666** have trapezoidal cross-sections, they or any other embodiment disclosed herein may optionally have but are not limited to the following, T-shaped cross-section, Y-Shaped cross-section, L-shaped cross-section or generally any cross-section that preferably results in the projections **664** and **666** being narrower at the ramped surfaces **680** and **682** than they are at the surfaces **665** and **667**. **FIG. 29B** shows an exemplary distal wedge **650** with the projections **664** and **666** having T-shaped cross-sections, which may be particularly preferable due to manufacturability and performance considerations. Optionally, in any embodiment, the slopes of the ramped surfaces **580** and **582**, and the slopes of the ramped surfaces **680** and **682** are equal or differ from each other. Since the branches of the ramped surfaces **580**, **582**, **680**, **682** of the wedges are intended to mate with the ramped surfaces **320** of the ramps **300**, **350**, **400**, **450**, the effects of varying their slopes is the same as discussed above for the ramped surfaces **320** in the ramp **300**. It should be understood that although the various alternative geometries of the distal wedges are presented here as discrete embodiments, these alternative embodiments have optional features which may be substituted or mixed/matched with any other embodiment in the specification. It should also be understood that substituting any of the aforementioned optional alternative features in the distal wedge component will necessitate the mating components (e. g. the endplates, the ramps, the actuator and the proximal wedge) to

use the inverse or complementary geometry to those features for proper engagement and that the shape of that inverse geometry would follow inevitably from the optional alternative feature geometry described above.

[0305] Turning now to method of implantation of the fusion device **1000** between two adjacent vertebral bodies **2** and **4**. **FIGS. 30, 31, and 32** show an embodiment of an inserter **800** configured to be reversibly attached to the fusion device **1000**, allow the fusion device **1000** to be implanted between the adjacent vertebral bodies **2** and **4** and facilitate graft delivery into the fusion device **1000**. Optionally, in any embodiment, the inserter **800** comprises an elongate main body **820** of a generally rectangular shape but may be other shapes in other embodiment, most preferably having a cross-section that is substantially the same as the transverse cross-section of the fusion device **1000** in the initial collapsed state. The inserter **800** further comprises a threaded shaft **840** slidably disposed in the main body. The main body **820** further comprises a distal end configured to mate with the proximal wedge **550** of the fusion device **1000** and includes three apertures running throughout the entire length of the main body **820**. The first aperture **821** allows the threaded shaft **840** to access one of the threaded side-apertures of the proximal wedge **550** allowing the reversible attachment of the inserter **800** to the fusion device **1000** by means of threading the threaded shaft **840** into the proximal wedge **550**. The second aperture **822** allows an expansion driver **870** to access the drive feature **512** of the actuator **500**. The expansion driver **870** is shown in **FIG. 33** and comprises a distal end including a drive feature **877** compatible with the drive feature **512** of the actuator **500** and a proximal end including an attachment feature **875** for a torque handle, a torque-limiting handle or a torque indicating handle used to actuate the actuator **500** and achieve expansion of the fusion device **1000**. The third aperture **823** allows access to a side aperture of the proximal wedge **550** for the purpose of delivering a therapeutic agent such as bone graft or bone growth inducing material into the fusion device **1000** post expansion. The distal end of the main body **820** further comprises flat planar plates forming ledges **825** and **827** intended to prevent height expansion of the fusion device **1000** until the width expansion is substantially complete. Once the inserter **800** is attached to the fusion device **1000** by means of threading the threaded shaft **840** into the proximal wedge **550** (see **FIG. 34**), the fusion device **1000** are implanted between the adjacent vertebral bodies **2** and **4** (see **FIG. 35**). Once the initial implanted position of the fusion device **1000** is found to be satisfactory, the expansion driver **870** is slidably introduced into the second aperture **822** in the inserter **800** and the drive feature **877** is engaged with the drive feature **512** of the actuator **500** (see **FIG. 36**). Applying torque to the expansion driver **870** now results in expansion of the fusion device **1000**. **FIG. 37** shows the inserter **800** attached to the fusion

device **1000** in fully collapsed state and the ledge **825** partially covering the endplates thereby preventing height expansion but allowing the width expansion of the fusion device **1000**. The ledge **825** in **FIG. 37** is shown covering a portion of the endplates and preventing height expansion of the fusion device **1000**. **FIG. 38** shows the inserter **800** attached to the fusion device **1000** in a state of partial width expansion and the ledge **825** partially covering the endplates thereby preventing height expansion but allowing further width expansion of the fusion device **1000**. **FIG. 39** shows the inserter **800** attached to the fusion device **1000** in a state of full width expansion and the ledge **825** no longer covering the endplates thereby allowing height expansion of the fusion device **1000**. **FIG. 40** shows the inserter **800** attached to the fusion device **1000** in a state of full width and height expansion. Bone graft or bone growth inducing material (graft material) is then introduced, delivered or injected into the fusion device **1000** through the third aperture **823** of the inserter **800**. Optionally, in any embodiment, graft material may be pre-packed into the third aperture **823** prior to attaching the inserter **800** and tamped through the third aperture **823** and into the fusion device **1000** using an elongated tamp (not shown) configured to fit through the third aperture **823** once the fusion device **1000** is implanted and expanded. It is further contemplated that graft material may be delivered into the proximal opening of the third aperture **823** by means including but not limited to a syringe, a funnel, a thread-actuated graft delivery device or a grip-operated graft delivery device after the device **1000** has been expanded. The elongated tamp is then used to push any graft material remaining inside the third aperture **823** into the fusion device **1000**. It is further contemplated that graft material are introduced into the fusion device **1000** after it has been expanded and after the inserter instrument has been detached, the graft are introduced through any of the available apertures in the proximal wedge **550** or through the gaps between the first vertebral endplate **6** and the proximal wedge **550** or through the gap between the second vertebral endplate **8** and the proximal wedge **550** or both at the same time. **FIG. 41** shows the fusion device **1000** in fully expanded state filled with bone graft material and still attached to the inserter **800**. **FIG. 42** shows the fusion device **1000** between the two adjacent vertebral bodies **2** and **4** in fully expanded state filled with bone graft and detached from the inserter **800**. The implantation of the fusion device **1000** is then complete and the surgical wound may then be closed.

[0306] **FIG. 43** shows an exemplary inserter instrument. An inserter **900** comprises a main shaft **955**, a sleeve **930**, a wheel **945**, a handle **915**, and pins **970** and **971**. The main shaft **955** further comprises a distal end configured to mate with the proximal wedge **550** of the fusion device **1000** and an external thread located proximate the proximal end. A detailed section view of the threaded articulation of the inserter is seen in **FIG. 44**. As shown in **FIGS. 45** and **46**, the main

shaft further includes three apertures running throughout the entire length of the main shaft **955**. The second aperture **961** allows an expansion driver **870** to access the drive feature **512** of the actuator **500**. The first aperture **961** and the third aperture **963** allow access to the side apertures of the proximal wedge **550** for the purpose of delivering bone graft or bone growth inducing material into the fusion device **1000** post expansion. The distal end of the main shaft **955** further comprises a first tang **956** including a distal protrusion **964** and a second tang **957** including a distal protrusion **965**. The tangs **956** and **957** are partially separated from the main bulk of the main shaft **955** by the slits **958** and **959**, which give the tangs flexibility. Distal ends of the tangs are configured to engage mating features of an exemplary proximal wedge **550**; this articulation is shown in a section view in **FIG. 47**. The sleeve **930** is configured to slide over the main shaft **955** and are advanced distally or proximally along the main shaft **955** by means of turning the wheel **945** which is threadably engaged with the main shaft **955** and rotationally engaged with the sleeve **930** by means of the pins **970** and **971**, which results in an articulation whereby the wheel **945** rotates relative to the sleeve **930** but not translate relative to it. The handle **915** is rigidly attached to the proximal end of the main shaft **955**. When the sleeve **930** is in its proximal-most position (shown in **FIG. 48**), the tangs **956** and **957** are allowed to elastically deform away from each other to engage the mating features on the proximal wedge **550** of the fusion device **1000**, and when the sleeve **930** is in its distal-most position (shown in **FIG. 49**), it prevents the tangs **956** and **957** from elastically deforming away from each other, resulting in a positive engagement between the proximal wedge **550** of the fusion device **1000** and the inserter **900**. Furthermore, in its distal-most state the sleeve **930** and specifically its distal end carries out the same function in the inserter **900** as the ledges **825** and **827** do in the inserter **800**, this function being preventing the fusion device **1000** from expanding in height until the width expansion has been substantially complete. Once the inserter **900** is attached to the fusion device **1000**, the fusion device **1000** is implanted between the adjacent vertebral bodies **2** and **4**. Once the initial implanted position of the fusion device **1000** is found to be satisfactory, the expansion driver **870** is introduced into the second aperture **962** in the inserter **900** and the drive feature **877** is engaged with the drive feature **512** of the actuator **500** (see **FIG. 50**). Applying torque to the expansion driver **870** now results in expansion of the fusion device **1000** first in width (see **FIG. 51**) and then in both width and height (see **FIG. 52**). The delivery of the bone graft material through the inserter **900** and into the fusion device **1000** may now be accomplished through one or both of the apertures **961** and **963** in the way discussed above. **FIG. 53** shows the fusion device **1000** in fully expanded state filled with bone graft material and still attached to the inserter **900**. The inserter **900** may then be detached from the fusion device **1000**, the

implantation of the fusion device **1000** is then complete, and the surgical wound may then be closed.

Second Expandable Fusion Device

[0307] Turning now to **FIGS. 54A-54C**, which show an exemplary second expandable fusion device **1000a**. **FIG. 54A** shows an exemplary second expandable fusion device **1000a** in a fully collapsed state, **FIG. 54B** shows an exemplary second expandable fusion device **1000a** in a fully expanded state and **FIG. 54C** shows an exploded view of an exemplary second expandable fusion device **1000a**. Optionally, in any embodiment, the second expandable fusion device **1000a** comprises an embodiment **300a** of the first ramp **300** (as well as the ramps **350a**, **400a** and **450a**, which are all identical in this embodiment, and the ramp **400a** is used to indicate the reference numbers for the ramp **300a** in **FIG. 54C**) is the same as the exemplary embodiment of the first ramp **300** with the following exceptions: the outer surface **327** includes ramped slot **335a** that is parallel to the ramped surfaces of the branch **323**, the branches **321** and **323** have generally C-shaped cross-sections, the surfaces **329** and **330** include protrusions **337a** and **338a**, the channel **328** has a generally T-shaped cross-section and does not include the groove **322** present in previously discussed embodiments of the ramp **300**.

[0308] The second expandable fusion device **1000a** further comprises an embodiment **100a** of the first endplate **100** (as well as the endplates **150a**, **200a** and **250a**, which are all identical in this embodiment, but may need to be suitably aligned in order to be assembled into the arrangement of the second expandable fusion device **1000a**) in which the ramped slots **107** and **109** have C-shaped cross-sections configured to mate with the ramp **300a**, the top surface **132** includes a protrusion **145a** proximate the slot **109** and a recess **146a** proximate the ramped slot **107**, whereas the protrusion **145a** and the recess **146a** have complementary shapes so that when two endplates are suitably rotated, the protrusion **145a** of one nests in the recess **146a** of the other allowing the bottom surface of the top endplate and the top surface of the bottom endplate to touch. The outward facing surface of the protrusion **145a** further includes a divot **147a** (shown in **FIG. 54C** on the endplate **200a**) that is generally aligned with the long axis of the ramped slots **335a** of the ramp **300a** when assembled but doesn't go all the way through to the other side of the endplate. Divot **147a** may have spherical, cylindrical (as shown) or any other shape. The purpose of the divot is to create an area of thinned material between the bottom of the divot and the inward surface of the ramped slot **109**, which allows to deform (peen) the bottom of the divot and create protruding dimple **148a** on the inward facing surface of slot **109** of the endplate. The peening step is performed as the last step in assembly process when the components are

assembled and are in a fully collapsed state and is performed by means of a punch or a pointed or rounded tool applying load to the bottom surface of the divot by means of impaction, pressing, or other means. As described above, the peening produces the dimple **148a** on the inward facing surfaces of the endplates, which in the assembled device state – lines up with and engages the ramped recesses of the ramps, capturing them and preventing dis-assembly of the second expandable fusion device **1000a** by hyper-expansion. Optionally, in any embodiment, the divots are replaced with thru-openings in the endplates and the function of the peened dimples are performed by pins pressed through the end endplate openings and engaging the ramped slots of the ramps. The endplate **100a** does not include tapered grooves **122**, **118**, **124** and **120** present in previously discussed embodiments of the endplate **100**, but instead includes ramped surfaces **121a** and **123a** (shown in **FIG. 54C** on the endplate **200a**), which perform generally the same function as the grooves **122**, **118**, **124** and **120**, which is to prevent height expansion from taking place until the device is sufficiently expanded in width. This is accomplished through the ramped surfaces **121a** and **123a** being in contact with mating ramped surfaces of the wedges throughout most of the width expansion process and while they are in contact with the wedges, the ramps on the opposing sides of each endplate are only able to move along the direction of the ramped surfaces of the wedges and the ramped surfaces **121a** and **123a**, while remaining static relative to one another, whereas to achieve height expansion the opposing ramps need to be able to move toward each other along the long axis of the device. Once the width expansion is substantially completed and once the ramped surfaces **121a** and **123a** no longer contact the wedges, the ramps are allowed to move toward each other resulting in height expansion. The top surface **132** further includes a protrusion **115a** proximate the ramped slot **107** and the inward surface **130** includes a recess **117a** proximate the slot **109**, whereas the protrusion **115a** and the recess **117a** have complementary shapes so that when two endplates are suitably rotated, the protrusion **115a** of one nests in the recess **117a** of the other allowing the opposing top and bottom surfaces of the two endplates to touch. Protrusion **115a** is configured to mate with the ramp **300a** as an extension of the ramped surfaces of the ramped slot **107**. The purpose of the protrusion **115a** is to increase device stability at the upper limits of allowed height expansion by maintaining a large contact area between the ramp and the endplate. The endplate **100a** further includes an opening **119a** extending from the inner surface to the outer surface. This feature is optional and is contemplated to allow graft material to exit the interior of the device and fill the space surrounding it. The endplate **100a** further includes a relief **149a** whose axis is substantially parallel to the long axis. The relief **149a** is configured to mate with the actuator **500a** and allow

the endplates to be in closer proximity to each other than would otherwise be possible without the relief **149a**.

[0309] The second expandable fusion device **1000a** further comprises an embodiment **500a** of the actuator **500**. The actuator **500a** comprises a proximal end **504a**, a distal end **502a** and a cylindrical surface **506a** connecting the proximal end **504a** and the distal end **502a**. Optionally, in any embodiment, the actuator **500a** further comprises a drive feature **512a** on the proximal end **504a**, a thread **517a** proximate the proximal end **504a**, and a thread **508a** proximate the distal end **502a**. The thread **508a** is comprised of a helical groove of opposite direction to that of the thread **508** (e. g. if the thread **508a** is right-handed, then the thread **517a** is left-handed or vice versa). This embodiment further includes a second drive feature on the distal end (not shown). This second drive feature is deemed useful in the event of a revision surgery where the revision approach is not the same as the approach used during the original surgery.

[0310] The second expandable fusion device **1000a** further comprises an embodiment **550a** of the proximal wedge **550**. The proximal wedge **550a** is shown in front and rear perspective views in **FIG. 55A** and **FIG. 55B** respectively. The proximal wedge **550a** comprises a first end **562a**, a second end **560a**, an upper surface **590a** connecting the first end **562a** and the second end **560a** and a lower surface **552** connecting the first end **562a** and the second end **560a**. The proximal wedge further comprises a first ramped surface **580a** and a second ramped surface **582a** located proximate the second end **560a**. The first ramped surface **580a** includes a first ramped recessed track **591a** proximate the upper surface and a second ramped recessed track **592a** proximate the lower surface. The first ramped surface **580a** further includes a projection **564a** extending from the first ramped surface **580a** towards a surface **565a** and having a generally T-shaped cross-section. The projection **564a** results in the ramped surface **580a** to be split into an upper portion and a lower portion. The second ramped surface **582a** includes a first ramped recessed track **593a** proximate the upper surface and a second ramped recessed track **594a** proximate the lower surface. The second ramped surface **582** includes a projection **566** extending from the second ramped surface **582a** toward a surface **567** and having a generally T-shaped cross-section. The projection **566a** results in the ramped surface **582a** to be split into an upper portion and a lower portion. The ramped recessed tracks **591a**, **592a**, **593a**, and **594a** do not break through the side surfaces of the wedge **550a** and function to limit the travel of the ramps relative to the proximal wedge by functioning as a depth stop for the protrusions **337a** and **338a** of the ramp **300a** to bottom out on. The upper surface **590a** further includes a projection **554a** extending from the upper surface **590a**. The lower surface **552a** further includes a projection **555** extending from the lower surface **552a**. The projections **554a** and **555a** include channels **599a** and **598a** extending

through the first end **562a** and the second end **560a**. It should be understood that the channels **599a** and **598a** are intended as a mating features for auxiliary instrumentation used in introduction, expansion of the second expandable fusion device **1000a** and/or graft delivery into the second expandable fusion device **1000a** and may be configured, shaped and located in other ways so long as they are accessible from the first end **562a**. The proximal wedge **550a** further comprises a threaded central aperture **568a** and generally rectangular apertures **570a** and **572a** which break through the respective sides of the proximal wedge **550a**. The proximal wedge **550a** further includes a partial bore **597a** extending from the first end **562a** to some depth toward, but not all the way to the second end **560a** and about centering on the major diameter of the threaded central aperture **568a** interrupting its threads. The partial bore **597a** allows to access the proximal end of the threaded actuator after the device has been expanded and to deform the first threads on it using a punch, awl, or an automatic punch tool. This is done to prevent or reduce the chances of the actuator unthreading post-operatively resulting in the device losing height.

[0311] The second expandable fusion device **1000a** further comprises an embodiment **650a** of the distal wedge **650** (best seen in exploded view in **FIG. 54C**) in this embodiment, the proximal wedge **650a** is identical to the proximal wedge **550a** with the exception that the distal wedge **650a** includes a central aperture that is threaded in the direction opposite to that of the proximal wedge. For example, if the central aperture of the proximal wedge **550a** has a left-handed thread, then the central aperture of the distal wedge **650a** has a right-handed thread. Optionally, in any embodiment, having all the insertion features present on the proximal wedge also being present on the distal wedge along with the actuator having a second drive feature on the distal end (as discussed above) is useful in the event of a revision surgery where the revision approach is not the same as the approach used during the original surgery. Optionally, in any embodiment, the distal wedge may have a more bulleted distal end to facilitate initial implantation.

[0312] It should also be understood that although the various alternative geometries of the various components are presented here as discrete embodiments, these alternative embodiments have optional features which may be substituted or mixed/matched with any other embodiment in the specification. It should also be understood that substituting any of the aforementioned optional alternative features in any of the components may or will necessitate the mating components to use the inverse or complementary geometry of those features for proper engagement and that the shape of that inverse or complementary geometry would follow inevitably from the optional alternative feature geometry described above and from the detailed description of the embodiments described as utilizing that geometry. As an example, the device second expandable fusion device utilizes some or any of the actuator embodiments, height and

width expansion features, configurations and embodiments as well as the endplate stabilization features and embodiments described here.

Third Expandable Fusion Device

[0313] Turning now to **FIGS. 56A-56C**, which show an exemplary third expandable fusion device **1000b**. **FIG. 56A** shows an exemplary third expandable fusion device **1000b** in a fully collapsed state, **FIG. 56B** shows an exemplary third expandable fusion device **1000b** in a fully expanded state and **FIG. 56C** shows an exploded view of an exemplary third expandable fusion device **1000b**. The third expandable fusion device **1000b** has similar functionality as the previously discussed embodiments in that it is configured transition from the initial collapsed state (shown in **FIG. 56A**) to the final expanded state (shown in **FIG. 56B**), but the expansion is accomplished using a modified mechanism where ramped slots of the ramp **300b** are configured to accept pins **600** inserted through the mating openings in the endplates **100b**. Since the endplates **100b** contain no ramped surfaces, the height expansion is accomplished by the pins **600** traveling along the ramped slots and by the various curved surfaces of the endplates making tangent contact with the ramped surfaces of the ramps. Disassembly by hyper-expansion is prevented by means of the pins **600** bottoming out in the ramped slots of the ramps **300b** at the limit of allowed travel. The third expandable fusion device **1000b** comprises an embodiment **300b** of the first ramp **300** (as well as the ramps **350**, **400** and **450**, which are all identical in this embodiment) shown in complementary views in **FIGS. 57A** and **57B** has a first end **301b** and a second end **303b**. The first ramp **300b** further comprises an inner surface **305b** connecting the first end **301b** and the second end **303b**, and an outer surface **307b** (best seen in **FIG. 57B**) connecting the first end **301b** and the second end **303b**. The first ramp **300b** further comprises an upper surface **309b** connecting the first end **301b** and the second end **303b**, and a lower surface **311b** connecting the first end **301b** and the second end **303b**, the two surfaces **309b** and **311b** being preferably parallel to each other. The first ramp **300b** further comprises a protuberance **315b** further comprising an upper branch **321b** extending preferably past the outer surface **307b** and the upper surface **309b**, and a lower branch **323b** extending preferably past the outer surface **307b** and the lower surface **311b**. The upper branch **321b** comprises an upper end surface **341b**, a first ramped surface **302b** and preferably a second ramped surface **310b**. The lower branch **323b** comprises a lower end surface **343b**, a first ramped surface **304b** and preferably a second ramped surface **312b**. The inner surface **305b** includes a projection **319b** forming a ramped surface **320b**. The projection **319b** includes a first branch **314b** and a second branch **316b**. The first branch **314b** extends from the ramped surface **320b** to a surface **329b** and the second branch

316b extends from the ramped surface **320b** to a surface **330b**. The ramped surface **320b** and the branches **314b** and **316b** form a channel **328b** having a generally T-shaped cross-section, which is formed due to the branches **314b** and **316b** including respective projections extending along and being parallel to the ramped surfaces **329b** and **330b** respectively and extending toward each other. The first branch **314b** further includes a projection **348b** and the second branch **316b** further includes a projection **349b**. The projection **319b** further includes a relief **306b** whose axis is substantially parallel to the long axis. The relief **306b** is configured to mate with the actuator **500a** and allow the ramps to be in closer proximity to each other than would otherwise be possible without the relief **306b**. The relief **306b** has any cross-section suitable to accomplish the function described above, for example a generally rectilinear cross-section. The ramp **300b** further comprises a first ramped slot **337b** recessed into the inner surface **305b** and extending from midplane of the ramp **300b** toward the upper branch **321b** but not breaking through the upper end surface **341b**, and a second ramped slot **338b** recessed into the outer surface **327b** and extending from the midplane of the ramp **300b** toward the branch **323b**, but not breaking through the lower end surface **343b**. The ramp **300b** further comprises a first ramped relief **341b** extending from the midplane of the ramp **300b** and toward the branch **321b** and disposed between the inner surface **305b** and the inner margin of the projection **319b** and a second ramped relief **342b** extending from the midplane of the ramp **300b** and toward the branch **323b** and disposed between the inner surface **305b** and the inner margin of the projection **319b**. The slope of the ramped reliefs may or may not be parallel to the respective ramped slots and the purpose of the ramped reliefs is to clear parts of the endplate during height expansion.

[0314] The third expandable fusion device **1000b** further comprises an embodiment **100b** (best seen in FIG. 58) of the first endplate **100** (as well as the endplates **150**, **200** and **250**, which are all identical in this embodiment) which comprises a first end **102b** and a second end **104b**. The first endplate **100b** further comprises an upper surface **134b** connecting the first end **102b** and the second end **104b**, and a lower surface **132b** connecting the first end **102b** and the second end **104b**. The first endplate **100b** further comprises a first elongated opening **107b** proximate the first end **102b** and a second elongated opening **109b** proximate the second end **104b**. The elongated openings **107b** and **109b** extend from the lower surface **132b** through the upper surface **140b** in the direction perpendicular to the long axis. The first endplate **100b** further comprises a first elongated recess **110b** extending from the first end **102b** and past the first elongated opening **107b** and a second elongated recess **112b** extending from the second end **104b** and past the second elongated opening **109b**. The elongated recesses **110b** and **112b** extend from the bottom surface **132b** toward but not through the upper surface **140b** in the direction

perpendicular to the long axis and forming a first inward face **114b** and a second inward face **116b** respectively.

[0315] The bottom surface **132b** includes a first protrusion **145b** proximate the opening **107b**, a second protrusion **145b1** proximate the opening **109b**, a first recess **146b** proximate the first opening **107b** and a second recess **146b1** proximate the second opening **109b**. Whereas the protrusions **145b** and **145b1** and the recesses **146b** and **146b1** have complementary shapes so that when two endplates are collapsed against each other, the protrusion **145b** of one nests in the recess **146b1** of the other and the protrusion **145b1** of one nests in the recess **146b** of the other, while allowing the respective top and bottom surfaces of the two endplates to touch and the inner surfaces **130b** of the two endplates to be aligned. The centers of the protrusions are configured to generally align with the ramped slots of the ramp **300b** when assembled. The protrusions **145b** and **145b1** further include thru openings **147b** and **147b1** respectively, configured to accept pins that would engage the ramped slots of the ramp **300b**. The inner surface **130b** further includes a relief **149b** whose axis is substantially parallel to the long axis. The relief **149a** is configured to mate with the actuator **500b** and allow the endplates to be in closer proximity to each other than would otherwise be possible without the relief **149b**. The inner surface **130b** further includes an opening **119b** extending from inward facing surface to the outward facing surface. This feature is optional and is contemplated to allow graft material to exit the interior of the device and fill the space surrounding it. The first inward face **114b** and the second inward face **116b** further include a first protrusion **118b** and a second protrusion **120b** respectively. The protrusions are rounded on the surfaces facing each other. The rounded sections of the protrusions **114b** and **116b** are configured to make tangent contact with the ramped surfaces **310b** and **312b** of the ramp **300b** to increase the contact area between the endplates and the ramps. The corners formed by at least the first end **102b** and the inward surface **130b** and by the second end **104b** and the inward surface **130b** include rounded surfaces **121b** and **123b** respectively. The purpose of these rounded surfaces is to help prevent height expansion from taking place until the device is sufficiently expanded in width. This is accomplished through the rounded surfaces **121b** and **123b** being in tangent contact with mating ramped surfaces of the wedges throughout most of the width expansion process and while they are in tangent contact with the wedges, the ramps **300b** on the opposing sides of each endplate **100b** are only able to move along the direction of the ramped surfaces of the wedges **550b** and **650b** as these ramped surfaces make tangent contact with rounded surfaces **121a** and **123a**, while the ramps **300b** remain static relative to one another, whereas to achieve height expansion the opposing ramps need to be able to move toward each other along the long axis of the device. Once the width expansion is substantially completed and

once the rounded surfaces **121a** and **123a** no longer tangentially contact the wedges, the ramps are allowed to move toward each other resulting in height expansion. The upper surface **134b** includes texturing **140b** to aid in gripping the adjacent vertebral bodies. Although In the illustrated embodiment, the texturing **140b** comprises series of parallel grooves running transversely to the long axis of the endplate **100b**, including but is not limited to teeth, ridges, areas of high surface roughness, metallic or ceramic coatings with relatively high surface roughness, friction increasing elements, keels, spikes, or gripping or purchasing projections. Optionally, in any embodiment, one or more of the endplates may be shorter, longer, narrower, or wider than others.

[0316] The third expandable fusion device **1000b** further comprises the proximal wedge **550a**, the distal wedge **650a**, the actuator **500a** and pins **600**.

[0317] It should also be understood that although the various alternative geometries of the various components are presented here as discrete embodiments, these alternative embodiments have optional features which may be substituted or mixed/matched with any other embodiment in the specification. It should also be understood that substituting any of the aforementioned optional alternative features in any of the components may or will necessitate the mating components to use the inverse or complementary geometry of those features for proper engagement and that the shape of that inverse or complementary geometry would follow inevitably from the optional alternative feature geometry described above and from the detailed description of the embodiments described as utilizing that geometry. As an example, the third expandable fusion device **1000b** may utilize some or any of the actuator embodiments, height and width expansion features, configurations and embodiments as well as the endplate stabilization features and embodiments described here.

Fourth Expandable Fusion Device

[0318] Turning now to **FIGS. 59A-59C**, which show an exemplary fourth expandable fusion device **1000c**. **FIG. 59A** shows an exemplary fourth expandable fusion device **1000c** in a fully collapsed state, **FIG. 59B** shows an exemplary fourth expandable fusion device **1000c** in a fully expanded state and **FIG. 59C** shows a top view of an exemplary fourth expandable fusion device **1000b**. The fourth expandable fusion device **1000c** is identical to the previously described third expandable fusion device **1000b** except that in the third expandable fusion device **1000c**, the endplates include nested interlocking stabilization features (best seen in **FIG. 59D**) allowing to improve stability, ensure proper alignment and reduce “slop” between top and bottom end-plates on either side of the device and facilitate even device expansion. Opposing endplates (**FIG. 59D**

for example shows the opposing endplates **100c** and **150c**) on top and bottom of the fourth expandable fusion device **1000c** include projections **111c1** and **111c2** directed toward each other as well as mating recesses **113c1** and **113c2** extending the length of the projections and through upper surfaces of the endplates. The recesses further contain a dovetailed track **103c2** on one endplate and a dovetailed projection **103c1** on the opposing endplate (best seen in **FIG. 59C**) so that the mating endplates only move in one dimension relative to each other, towards or away from each other along the long axis of the dovetailed track. Whereas the projections **111c1** and **111c2** and the recesses **113c1** and **113c2** have complementary shapes so that when two endplates are suitably rotated, the projection **111c1** of one nests in the recess **113c2** of the other and the recess **113c1** of one accepts the projection **111c2** of the other, while allowing the lower surfaces of the two endplates to touch and the inner and outer surfaces of the two endplates to be aligned. It should be understood that although the stabilization features of this embodiment have been shown here to slidably interconnect upper and lower endplate portions, the same arrangement is also be used to slidably interconnect the upper pairs or lower pairs of the endplate portions, or to slidably interconnect both the upper pairs, the lower pairs and the upper and lower endplate portions.

[0319] It should also be understood that although the various alternative geometries of the various components are presented here as discrete embodiments, these alternative embodiments have optional features which may be substituted or mixed/matched with any other embodiment in the specification. It should also be understood that substituting any of the aforementioned optional alternative features in any of the components may or will necessitate the mating components to use the inverse or complementary geometry of those features for proper engagement and that the shape of that inverse or complementary geometry would follow inevitably from the optional alternative feature geometry described above and from the detailed description of the embodiments described as utilizing that geometry. As an example, the fourth expandable fusion device **1000c** may utilize some or any of the actuator embodiments, height and width expansion features, configurations and embodiments as well as the endplate stabilization features and embodiments described here.

Fifth Expandable Fusion Device

[0320] Turning now to **FIGS. 60A-60C**, which show an exemplary fifth expandable fusion device **1000d**. **FIG. 60A** shows an exemplary fifth expandable fusion device **1000d** in a fully expanded state and **FIG. 60B** shows a side view of an exemplary fifth expandable fusion device **1000d** in a fully expanded state. The fifth expandable fusion device **1000d** is identical to the

previously described fourth expandable fusion device **1000c** except that in the fifth expandable fusion device **1000d**, the endplates contain nested interlocking stabilization features, in which the projections **111c1** and **111c2** described above in relation to the device **1000c**, also include curved protrusions **111d3** and **111d4** respectively, and the recesses **113c1** and **113c2** described above in relation to the device **1000c**, also include curved reliefs **113d3** and **113d4** respectively, which are configured to accept the curved protrusions **111d3** and **111d4** in a nesting fashion. The curved protrusions are configured to tangentially contact the ramped surfaces of the ramps **300b** thereby providing additional contact points between the ramps and the endplates and resulting in improved device stability at the upper limits of allowable height expansion. The endplates of the fifth expandable fusion device **1000d** contain no ramped surfaces and rely on the pin components to transmit expansion force between the ramps and the endplates, which may lead to undesired motion (or slop) between these components due to low contact area. Adding curved features (such as the curved protrusions **111d3** and **111d4**) to the endplates allows to approximate a continuous contact surface between the ramps and the endplates thereby improving stability as mentioned above.

[0321] It should also be understood that although the various alternative geometries of the various components are presented here as discrete embodiments, these alternative embodiments have optional features which may be substituted or mixed/matched with any other embodiment in the specification. It should also be understood that substituting any of the aforementioned optional alternative features in any of the components may or will necessitate the mating components to use the inverse or complementary geometry of those features for proper engagement and that the shape of that inverse or complementary geometry would follow inevitably from the optional alternative feature geometry described above and from the detailed description of the embodiments described as utilizing that geometry. As an example, the fifth expandable fusion device **1000d** may utilize some or any of the actuator embodiments, height and width expansion features, configurations and embodiments as well as the endplate stabilization features and embodiments described here.

Sixth Expandable Fusion Device

[0322] Turning now to **FIGS. 61A-61B**, which show an exemplary sixth expandable fusion device **1000e**. **FIG. 61A** shows an exemplary sixth expandable fusion device **1000e** in a fully expanded state and **FIG. 61B** shows an exploded view of an exemplary sixth expandable fusion device **1000e**. The sixth expandable fusion device **1000e** comprises an embodiment **100e** of the first endplate **100** (as well as the endplates **150**, **200** and **250**, whereas the endplates **100e** and

150e are identical and the endplates **250e** and **200e** are mirrors of the endplates **100e** and **150e**), which is identical to the endplate **100** with the following exceptions. In the endplate **100e**, the slots **107** and **109** have a generally C-shaped cross-sections and have equal slopes inclined in the same direction, whereas both the slots **107** and **109** start at the upper surface **134** and slope toward the second end **104**, the bottom surface **132** includes a protrusion **145e** proximate the slot **109** and a recess **146e** proximate the slot **107**, whereas the protrusion **145e** and the recess **146e** have complementary shapes so that when top and bottom endplates are collapsed against each other, the protrusion **145a** of one nests in the recess **146e** of the other allowing the respective top and bottom surfaces of the opposing endplates to touch. The protrusion **145e** further includes an opening **147e** (shown in **FIG. 61B** on the endplate **150a**) that is generally aligned with the ramped slots **335e** of the ramp **300e** when assembled and is configured to accept the pin **600**, which then engage the ramped slots in the ramp **300e**.

[0323] The endplate **100e** does not include tapered grooves **122**, **118**, **124** and **120** present in previously discussed embodiments of the endplate **100**, but instead includes ramped surfaces **121e** and **123e**, which perform generally the same function as the grooves **122**, **118**, **124** and **120**, which is to prevent height expansion from taking place until the device is sufficiently expanded in width. This is accomplished through the ramped surfaces **121e** and **123e** being in contact with mating ramped surfaces of the wedges throughout most of the width expansion process and while they are in contact with the wedges, the ramps on the opposing sides of each endplate are only able to move along the direction of the ramped surfaces of the wedges and the ramped surfaces **121e** and **123e**, while remaining static relative to one another, whereas to achieve height expansion the opposing ramps need to be able to move toward each other along the long axis of the device. Once the width expansion is substantially completed and once the ramped surfaces **121e** and **123e** no longer contact the wedges, the ramps are allowed to move toward each other resulting in height expansion. The endplate **100e** further includes an opening **119e** extending from the upper surface through to the lower surface in the direction perpendicular to the long axis. The purpose of the opening **119e** is to be engaged by mating protuberances **315e** of the ramp **350e** or **450e**. The endplate **100a** further includes a rectilinear relief **149e** spanning the distance between the slots **107** and **109**. The purpose of the relief **149e** is to allow the ramps **300e** and **400e** to mate properly with the endplates.

[0324] The sixth expandable fusion device **1000e** further comprises a distal ramp **350e** and a distal ramp **450e**, which are identical and will henceforth be referred to as the distal ramp **350e**. The sixth expandable fusion device **1000e** further comprises a proximal ramp **300e** and a proximal ramp **400e**, which are identical and will henceforth be referred to as the proximal ramp

300e. The distal ramp **350** is the same as the ramp **300b** described above with the following exceptions: the distal ramp **350e** does not include the protuberance **315b** or the ramped slots present in the ramp **300b** and instead includes a protuberance **315e**, which extends past the upper surface **309b**, past the lower surface **311b** and past the outer surface **307b** and has an elongated shape extending generally in the direction normal to the upper and lower surfaces. The proximal ramp **300e** is the same as the ramp **300b** described above with the following exceptions: in the proximal ramp **300e**, the ramped slot **337b** is recessed into the outer surface **327b** as opposed to the inner surface **305b** as it is in the previously described ramp **300b**, this results in both the ramped slots **337b** and **338b** being on the same side of the proximal ramp **300e**, and merging together at the mid-plane. The proximal ramp **300e** does not include the ramped reliefs **341b** and **342b**, the branches **323b** and **321b** of the protrusion **315b** have generally C-Shaped cross-sections, and the proximal ramp **300e** further includes a protrusion **315e1** connected to the tip of the proximal ramp **300e** by an isthmus **315e2** and forming a first end **301e** of the proximal ramp **300e**. The protrusion **315e1** is identical to the protrusion **315b** including having the two ramped slots **338e** and **337e** which are both recessed into the outer surface **327e** coplanar with the outer surface **327b**. The tip of the protrusion **315e1** forming the first end **301e** is truncated to be shorter than that of the protrusion **315b**.

[0325] The sixth expandable fusion device **1000e** further comprises the actuator **500a**, the proximal wedge **550a**, the distal wedge **650a** and the pins **600** configured to press into the mating openings of the endplates and to engage the ramped slots **338b**, **337b**, **338e** and **337e** of the proximal ramps to provide stability and prevent device disassembly due to hyper-expansion, by bottoming out in the ramped slots at the end of maximum allowed travel and height expansion. As in other embodiments of the fusion device, after the sixth expandable fusion device **1000e** has substantially reached the maximum width expansion, further drawing the wedges together causes the proximal ramps and distal ramps to move toward each other. The proximal ramps are engaged with the ramped slots of the endplates and effect height expansion by moving relative to the endplates in both the direction of the long axis of the device and the direction of height expansion and along the angle of the mated ramped surfaces of the endplates and the proximal ramps, whereas the distal ramps only move relative to the endplates in the direction of the height expansion. Optionally, in any embodiment, replacing the ramps **350e** and **450e** with the ramps **350a** and **450a**, as well as adding mating ramped slot to the endplates to provide mating geometry for the ramps **350a** and **450a** would result in an embodiment with desirable characteristics including improved endplate stability and easier and more uniform height expansion.

[0326] It should also be understood that although the various alternative geometries of the various components are presented here as discrete embodiments, these alternative embodiments have optional features which may be substituted or mixed/matched with any other embodiment in the specification. It should also be understood that substituting any of the aforementioned optional alternative features in any of the components may or will necessitate the mating components to use the inverse or complementary geometry of those features for proper engagement and that the shape of that inverse or complementary geometry would follow inevitably from the optional alternative feature geometry described above and from the detailed description of the embodiments described as utilizing that geometry. As an example, the sixth expandable fusion device **1000e** may utilize some or any of the actuator embodiments, height and width expansion features, configurations and embodiments as well as the endplate stabilization features and embodiments described here.

Seventh Expandable Fusion Device

[0327] Turning now to **FIGS. 62A-62B**, which show an exemplary seventh expandable fusion device **1000f**. **FIG. 62A** shows an exemplary seventh expandable fusion device **1000f** in a fully expanded state and **FIG. 62B** shows an exploded view of an exemplary seventh expandable fusion device **1000f**. In this embodiment, the ramps in the front end of the seventh expandable fusion device **1000f** engage the rear ramped surfaces of the endplates and the ramps on the rear of the device engage the front ramped surfaces on the endplates, causing the device to expand in height as the front and rear ramps are forced together when the actuator is actuated. The seventh expandable fusion device **1000f** comprises an embodiment **100f** of the first endplate **100** (as well as the endplates **150**, **200** and **250**, whereas the endplates **100f** and **250f** are identical and the endplates **150f** and **200f** are mirrors of the endplates **100f** and **250f**) in which the slots **107** and **109** have “sideways T”-shaped cross-sections, have equal slopes and are inclined in the opposing directions, whereas the slot **107f** extends through the inner surface **132f** and the slot **109f** extends through the outer surface **134f**.

[0328] The endplate **100f** does not include tapered grooves **122**, **118**, **124** and **120** present in previously discussed embodiments of the endplate **100**, but instead includes rounded surfaces **121f** proximate the first end **102** and rounded surfaces **123f** proximate the second end **104**, which perform generally the same function as the grooves **122**, **118**, **124** and **120**, which is to prevent height expansion from taking place until the device is sufficiently expanded in width. This is accomplished through the rounded surfaces **121f** and **123f** being in tangent contact with mating ramped surfaces of the wedges throughout most of the width expansion process and while they

are in contact with the wedges, the ramps on the opposing sides of each endplate are only able to move along the direction of the ramped surfaces of the wedges as they maintain tangent contact with the rounded surfaces **121f** and **123f**, while remaining static relative to one another, whereas to achieve height expansion the opposing ramps need to be able to move toward each other along the long axis of the device. Once the width expansion is substantially completed and once the rounded surfaces **121f** and **123f** lose their tangent contact with the wedges, the ramps are allowed to move toward each other resulting in height expansion. Optionally, in any embodiment, the rounded surfaces **121f** and **123f** are also ramped planar surfaces generally parallel to the ramped surfaces of the wedges to achieve the same height expansion-limiting effect as described above.

[0329] The endplate **100f** further includes a rectilinear relief **149f** spanning the distance between the slot **107f** and the second end **104** and a corresponding relief on the other side that is the same and is not seen spanning the distance between the slot **109** and the first end **102**. The purpose of the reliefs is to allow the ramps **300f** and **350f** to mate properly with the endplates. The endplate **100f** further includes reliefs **149f3** in both the inner surface **132f** and the outer surface **134f**, whose axes are substantially parallel to the long axis. The reliefs **149f3** are configured to mate with the actuator **500a** and allow the endplates to be in closer proximity to each other than would otherwise be possible without the relief **149f3**. The reason for there being two reliefs **149f3** is that since, as discussed above, the endplate **100f** is identical to the endplate **250** and the endplate **150f** is identical to the endplate **200f**, depending on whether the endplate **100f** is assembled in the seventh expandable fusion device **1000f** in the left or the right position, the inner surface **132f** of the endplate **100f** may form either an inner or an outer margin of the assembled device. With this in mind, the endplate **100f** includes two reliefs **149f3** in order to keep the left and right endplate components identical in this embodiment, even though only one of the reliefs **149f3** actually contacts the actuator **500a** in any given endplate in any given assembly.

[0330] The seventh expandable fusion device **1000f** further comprises a proximal outside ramp **300f** and a distal outside ramp **450f**, which are identical and will henceforth be referred to as the outside ramp **300f**. The fusion device **1000e** further comprises a proximal inside ramp **400f** and a distal inside ramp **350f**, which are identical and will henceforth be referred to as the inside ramp **350f**. Here the ramps are described as inside and outside based on whether their ramped surfaces make contact with the inner or the outer slots in the endplates. The inside ramp **350f** is the same as the ramp **300b** described above with the following exceptions: the inside ramp **350f** does not include the ramped slots **337b** and **338b** or the ramped reliefs **341b** and **342b** present in the ramp **300b**, the branches **321f** and **323f** have sideways-T-shaped cross-sections configured to mate

with similarly shaped slots **107f** and **109f** of the endplates. The inside ramp **350f** is longer than the ramp **300b** and has a truncated tip proximate the first end **301b**. The inside ramp **350f** is configured to engage the inward facing slots of the endplates and to allow the outside ramp **300f** to clear the outer surfaces of the outside ramp **350f** while itself engaging the outward facing slots of the endplates.

[0331] The outside ramp **300f** is the same as the ramp **300b** described above with the following exceptions: the inside ramp **300f** does not include the ramped slots present in the ramp **300b**, the branches **321f** and **323f** have sideways-T-shaped cross-sections configured to mate with similarly shaped slots **107f** and **109f** of the endplates. The inside ramp **350f** is longer than the ramp **300b** and has a truncated tip proximate the first end. Furthermore, the protuberance **315f** of the outside ramp **300f** protrudes past both the outer surface **307f** and the inner surface **305f** as opposed to the protuberance **315b** of the ramp **300b** which only protrudes past the outer surface **307b**. The outside ramp **300f** is configured to engage the outward facing slots of the endplates and to allow the inside ramp **350f** to clear the inner surfaces of the outside ramp **300f** while itself engaging the inward facing slots of the endplates.

[0332] The seventh expandable fusion device **1000f** further comprises the actuator **500a**, the proximal wedge **550a**, and the distal wedge **650a**. As in other embodiments of the fusion device, after the device **1000e** has substantially reached the maximum width expansion, further drawing the wedges together causes the proximal ramps and distal ramps to move toward each other. The proximal ramps are engaged with the ramped slots of the endplates and effect height expansion by moving relative to the endplates in both the direction of the long axis of the device and the direction of height expansion and along the angle of the mated ramped surfaces of the endplates and the proximal ramps. Disassembly of the seventh expandable fusion device **1000f** through hyper expansion are prevented using a variety of methods described in other embodiments above as well as those that will be obvious to one skilled in the art. One additional contemplated method for achieving this is to assemble the device in the state of height expansion that is greater than desired maximum allowable height, then reduce the height slightly once the device is fully assembled and then deform the threads of the actuator **500a** in such a way so as to no longer allow the seventh expandable fusion device **1000f** to return to its initial hyper-expanded state required for assembly or disassembly of components.

[0333] It should also be understood that although the various alternative geometries of the various components are presented here as discrete embodiments, these alternative embodiments have optional features which may be substituted or mixed/matched with any other embodiment in the specification. It should also be understood that substituting any of the aforementioned

optional alternative features in any of the components may or will necessitate the mating components to use the inverse or complementary geometry of those features for proper engagement and that the shape of that inverse or complementary geometry would follow inevitably from the optional alternative feature geometry described above and from the detailed description of the embodiments described as utilizing that geometry. As an example, the seventh expandable fusion device **1000f** may utilize some or any of the actuator embodiments, height and width expansion features, configurations and embodiments as well as the endplate stabilization features and embodiments described here.

Eighth Expandable Fusion Device

[0334] Turning now to **FIGS. 63A-63D**, which show an exemplary eighth expandable fusion device **1000g** in which each of the endplates comprise a front portion and a rear portion, the front portion and the rear portion further include mating cut-outs and circular openings which allow the portions to be pivotably connected with a pin (or with an integral cylindrical protrusion on one of the portions engaging a mating hole in the other portion). The pin may be pressed or welded or machined as a protrusion into one portion, inserted into the other portion and its free end swaged to prevent disassembly. The ramps include cylindrical protrusions that engage the ramped slots in the wedges, which allow the ramps to both translate and rotate relative to the wedges. The slots also limit how far the ramps translate relative to the wedges, including a contemplated configuration in which no translation is allowed and the ramps are only able to rotate relative to the wedges. Such configuration is achieved by adjusting the length of the slots so that at the initial collapsed state, the ramps only pivot or rotate relative to their respective wedges as the width expansion occurs. The eighth expandable fusion device **1000g** functions in a fashion identical to the fusion device **1000a**, with the following exceptions. The ramps of the eighth expandable fusion device **1000g** are able to both translate and rotate relative to the wedges, this combined with the fact that each of the endplates is comprised of two pivotably connected portions results in the eighth expandable fusion device **1000g** being able to expand in width by both translating opposing endplates away from each other, and by allowing the endplates to articulate in to a generally diamond-shaped or square configuration in a width expanded state.

[0335] The eighth expandable fusion device **1000g** comprises an embodiment **100g** of the first endplate **100** (as well as the endplates **150**, **200** and **250**, whereas the compound endplates **100g**, **250g**, **150g** and **200g** are all identical but rotated relative to each other for proper assembly). The compound endplate **100g** is identical to the endplate **100a** described above with the following

exceptions. The compound endplate **100g** comprises two portions **100g1** and **100g2** pivotably connected with pin **600** through the center of the compound endplate **100g**. Each of the portions **100g1** and **100g2** contain complementary reliefs **149g1** and **149g2** and circular openings **119g1** and **119g2**, which when concentrically aligned allow the upper surfaces and the lower surfaces of the portions **100g1** and **100g2** to be aligned in a generally co-planar fashion and allowed to pivot around the axis of the openings **119g1** and **119g2**.

[0336] The eighth expandable fusion device **1000g** further comprises an embodiment **300g** of the ramp **300** (as well as the ramps **350**, **400** and **450**, whereas the ramps **300g**, **350g**, **400g** and **450g** are all identical in this embodiment but are rotated relative to each other for proper assembly). The ramp **300g** is identical to the ramp **300a** described above with the following exceptions. The branches **316g** and **314g** form a channel **328g** having a generally rectangular cross-section as opposed to the channel **328a** of the ramp **300a** having a T-shaped cross-section. The surfaces **330a** and **329a** do not include protrusions **349a** and **348a** as they do in the ramp **300a**. The branches **316g** and **314g** further include ramped surfaces **330g1** and **329g1** in addition to the ramped surfaces **330a** and **329a** of the ramp **300a**, whereas the surfaces **330g1** and **329g1** are at an angle to the surfaces **330a** and **329a**. The branches **316g** and **314g** further include cylindrical protrusions **349g** and **348g** respectively. Whereas the cylindrical protrusions share the same central axis and are tangent to the surfaces **330a**, **329a**, **316g** and **314g**. The purpose of the protrusions **349g** and **348g** is to translationally and pivotably engage the mating slots of the wedges.

[0337] The eighth expandable fusion device **1000g** further comprises an embodiment **550g** of the distal wedge **550**. The distal wedge **550g** (shown in detail in FIG. 64) is identical to the distal wedge **550a** with the following exceptions. The distal wedge **550g** does not include ramped recessed tracks **591a**, **592a**, **593a** and **594a**, but does include protrusions **564g** and **566g** which include ramped recessed tracks **591g** and **593g** respectively formed in the upper surfaces of the protrusions **564g** and **566g**, and further include ramped recessed tracks **592g** and **594g** respectively formed in the lower surfaces of the protrusions **564g** and **566g**. The protrusions **555g** and **554g** include ramped surfaces **596g**, **597g**, which are configured to allow the endplates to move relative to the wedges once the eighth expandable fusion device **1000g** is fully expanded in width. Channel **598g** of the proximal wedge does not break through the protrusion **555g**.

[0338] The eighth expandable fusion device **1000g** further comprises an embodiment **650g** of the distal wedge **650**. In this embodiment, the proximal wedge **650g** is identical to the proximal wedge **550g** with the exception that the distal wedge **650a** includes a central aperture that is threaded in the direction opposite to that of the proximal wedge. For example, if the central

aperture of the proximal wedge **550g** has a left-handed thread, then the central aperture of the distal wedge **650g** has a right-handed thread. Optionally, in any embodiment, having all the insertion features present on the proximal wedge also being present on the distal wedge along with the actuator having a second drive feature on the distal end (as discussed above) is useful in the event of a revision surgery where the revision approach is not the same as the approach used during the original surgery. Optionally, in any embodiment, the distal wedge may have a more bulleted distal end to facilitate initial implantation.

[0339] The eighth expandable fusion device **1000g** further comprises the actuator **500a** and the pins **600**.

[0340] It should also be understood that although the various alternative geometries of the various components are presented here as discrete embodiments, these alternative embodiments have optional features which may be substituted or mixed/matched with any other embodiment in the specification. It should also be understood that substituting any of the aforementioned optional alternative features in any of the components may or will necessitate the mating components to use the inverse or complementary geometry of those features for proper engagement and that the shape of that inverse or complementary geometry would follow inevitably from the optional alternative feature geometry described above and from the detailed description of the embodiments described as utilizing that geometry. As an example, the eighth expandable fusion device **1000g** may utilize some or any of the actuator embodiments, height and width expansion features, configurations and embodiments as well as the endplate stabilization features and embodiments described here.

Ninth Expandable Fusion Device

[0341] Turning now to **FIGS. 65A-65E**, which show an exemplary ninth expandable fusion device **1000h**. **FIG. 65A** shows an initial collapsed state of an exemplary ninth expandable fusion device **1000h**, **FIG. 65B** shows a fully expanded state of an exemplary ninth expandable fusion device **1000h**, **FIG. 65C** shows a partially assembled view of an exemplary ninth expandable fusion device **1000h** in a collapsed state, **FIG. 65D** shows a partially assembled view of an exemplary ninth expandable fusion device **1000h** in a state of full linear width expansion and **FIG. 65E** shows a partially assembled view of an exemplary ninth expandable fusion device **1000h** in a state of full linear and angular expansion. In the ninth expandable fusion device **1000h** each of the endplates comprise a front portion and a rear portion, the front portion and the rear portion further include mating cut-outs and circular openings which allow the portions to be pivotably connected with a pin (or with an integral cylindrical protrusion on one of the portions

engaging a mating hole in the other portion). The pin may be pressed or welded or machined as a protrusion into one portion, inserted into the other portion and its free end swaged to prevent disassembly. The ramps include cylindrical protrusions that engage the ramped slots in the wedges, which allow the ramps to both translate and rotate relative to the wedges. The slots also limit how far the ramps translate relative to the wedges. The ninth expandable fusion device **1000h** functions in a fashion identical to the third expandable fusion device **1000b**, with the following exceptions. The ramps of the ninth expandable fusion device **1000h** are able to both translate and rotate relative to the wedges, this combined with the fact that each of the endplates is comprised of two pivotably connected portions results in the ninth expandable fusion device **1000h** being able to expand in width by both translating opposing endplates away from each other, and by allowing the endplates to articulate in to a generally diamond-shaped or square configuration in a width expanded state.

[0342] The ninth expandable fusion device **1000h** comprises an embodiment **100h** of the first endplate **100** (as well as the endplates **150**, **200** and **250**, whereas the compound endplates **100h**, **250h**, **150h** and **200h** are all identical but rotated relative to each other for proper assembly). The compound endplate **100h** is identical to the endplate **100b** described above including having the rounded surfaces **121b** and **123b** with the exception that it comprises two portions that are pivotably connected exactly as described above for the endplate **100g**.

[0343] The ninth expandable fusion device **1000h** further comprises an embodiment **300h** of the ramp **300** (as well as the ramps **350**, **400** and **450**, whereas the ramps **300h**, **350h**, **400h** and **450h** are all identical in this embodiment but are rotated relative to each other for proper assembly). The ramp **300h** is identical to the ramp **300b** described above with some exceptions. The ramp **300h** differs from the ramp **300b** in exactly the same ways that the ramp **300g** described above differs from the ramp **300a** described above including having the cylindrical protrusions **349g** (best seen in **FIG. 65C**) and **348g** (shown in figures pertaining to the discussion of the device **1000g**). It should be understood that if in the initial collapsed state of the ninth expandable fusion device **1000h**, the rounded surfaces **121b** and **123b** of the endplates **100h** are concentric or near concentric with the cylindrical protrusions **349g** and **348g** of the ramp **300h** (this articulation is best seen in **FIGS. 65C, 65D** and **65E**), the ninth expandable fusion device **1000h** will be able to expand in width both linearly and angularly starting immediately at the initial collapsed state due to the fact that in this scenario, both the ramp and the endplate portions will be able to rotate relative to the wedges around a common axis. Whereas if the rounded surfaces **121b** and **123b** of the endplates **100h** are not concentric or with the cylindrical protrusions **349g** and **348g** of the ramp **300h**, the ninth expandable fusion device

1000h will start width expansion in a linear fashion and only be able to expand angularly after the contact is lost between the rounded surfaces of the endplates and the wedges. This is because for the rounded surfaces of the endplates and the cylindrical protrusions of the ramps are not coaxial, but still maintain simultaneous tangent contact with the ramped surfaces of the wedges and are therefore unable to rotate relative to the wedges until the ninth expandable fusion device **1000h** is sufficiently expanded in width where the rounded surfaces lose contact with the ramped surfaces of the wedges.

[0344] The ninth expandable fusion device **1000h** further comprises the proximal wedge **550g**, the distal wedge **650g**, the actuator **500a**, and the pins **600**.

[0345] It should also be understood that although the various alternative geometries of the various components are presented here as discrete embodiments, these alternative embodiments have optional features which may be substituted or mixed/matched with any other embodiment in the specification. It should also be understood that substituting any of the aforementioned optional alternative features in any of the components may or will necessitate the mating components to use the inverse or complementary geometry of those features for proper engagement and that the shape of that inverse or complementary geometry would follow inevitably from the optional alternative feature geometry described above and from the detailed description of the embodiments described as utilizing that geometry. As an example, the ninth expandable fusion device **1000h** may utilize some or any of the actuator embodiments, height and width expansion features, configurations and embodiments as well as the endplate stabilization features and embodiments described here.

Tenth Expandable Fusion Device

[0346] Turning now to **FIG. 66A**, which shows an exemplary tenth expandable fusion device **1000k** in a fully expanded state, whereas the tenth expandable fusion device **1000k** comprises an upper endplate **100k** comprising two portions **100k1** and **100k2** connected together into a single component by a series of angled deformable struts **100k3** and further comprising a lower endplate **200k** comprising two portions **200k1** and **200k2** connected together into a single component by a series of angled deformable struts **200k3**. The portions **100k1**, **100k2** and **200k1** and **200k2** may be identical to any of the embodiments of the endplates **100**, **150**, **200**, and **250** described above. The angled deformable struts **100k3** and **200k3** are chevron or V-shaped in this embodiment but are of any other suitable shape including U-Shaped, W-shaped, and Z-Shaped etc. The struts are configured to deform upon width expansion of the device with the angles between the surfaces of the struts increasing through the width expansion process from some

initial angle at the initial collapsed state (shown in **FIG. 66B**) to a larger angle at a full width expanded state (shown in **FIG. 66C**). With the exception of the two portions of the upper and lower endplates being integrally connected by angled deformable struts, the components comprising the tenth expandable fusion device **1000k** are identical to any of their embodiments described above. During the width expansion step, the series of angled deformable struts connecting the portions comprising the upper and lower endplates are plastically deformed by the action of the actuator and the wedges to permanently bring the upper and the lower endplates from the initial collapsed state (shown in **FIG. 66D**) into a width expanded state.

[0347] It should also be understood that although the various alternative geometries of the various components are presented here as discrete embodiments, these alternative embodiments have optional features which may be substituted or mixed/matched with any other embodiment in the specification. It should also be understood that substituting any of the aforementioned optional alternative features in any of the components may or will necessitate the mating components to use the inverse or complementary geometry of those features for proper engagement and that the shape of that inverse or complementary geometry would follow inevitably from the optional alternative feature geometry described above and from the detailed description of the embodiments described as utilizing that geometry. As an example, the tenth expandable fusion device **1000k** may utilize some or any of the actuator embodiments, height and width expansion features, configurations and embodiments as well as the endplate stabilization features and embodiments described here.

Eleventh Expandable Fusion Device

[0348] Turning now to **FIG. 67A**, which shows an exemplary eleventh expandable fusion device **1000m** in a fully expanded state, whereas the eleventh expandable fusion device **1000m** comprises an endplate complex **100m** (shown in **FIG. 67B**) comprising upper portions **100m1** and **100m2** and lower portions **200m1** and **200m2**. Whereas all four portions are integrally connected together by series of angled (or, in other embodiments, curved) deformable struts, whereas the two upper portions are connected together by angled deformable struts **250m1** and the two lower portions are connected together by angled deformable struts **250m1** and whereas the upper portions are connected to the lower portions by angled deformable struts **250m2**. The portions **100m1**, **100m2** and **200m1** and **200m2** may be identical to any of the embodiments of the endplates **100**, **150**, **200** and **250** described above. The angled deformable struts **250m1** and **250m2** are chevron or V-shaped in this embodiment but are of any other suitable shape including U-Shaped, W-shaped, and Z-Shaped etc. The struts **250m1** are configured to deform with width

expansion and the struts **250m2** are configured to deform with height expansion of the device with the angles between the surfaces of the struts increasing through the expansion process from some initial angle at the initial collapsed state (shown in **FIG. 67C**) to a larger angle at a full width expanded state (shown in **FIG. 67D**) and at a full width and height expanded state. With the exception of the portions of the endplates being integrally connected by angled deformable struts into the endplate complex **100m**, the components comprising the eleventh expandable fusion device **1000m** are identical to any of their embodiments described above. During the device expansion, the series of angled deformable struts connecting the portions comprising the endplate complex are plastically deformed by the action of the actuator, the wedges and the ramps to permanently bring the endplate complex **100m** from the initial collapsed state into a width expanded state and then into a width and height expanded state.

[0349] It should also be understood that although the various alternative geometries of the various components are presented here as discrete embodiments, these alternative embodiments have optional features which may be substituted or mixed/matched with any other embodiment in the specification. It should also be understood that substituting any of the aforementioned optional alternative features in any of the components may or will necessitate the mating components to use the inverse or complementary geometry of those features for proper engagement and that the shape of that inverse or complementary geometry would follow inevitably from the optional alternative feature geometry described above and from the detailed description of the embodiments described as utilizing that geometry. As an example, the eleventh expandable fusion device **1000m** may utilize some or any of the actuator embodiments, height and width expansion features, configurations and embodiments as well as the endplate stabilization features and embodiments described here.

Twelfth Expandable Fusion Device

[0350] Turning now to **FIGS. 68-72C**, which show an exemplary twelfth expandable fusion device **1000n** and its components. **FIG. 68** shows an initial collapsed state of an exemplary twelfth expandable fusion device **1000n**, which is identical to an third expandable fusion device **1000b** described above with the exceptions described below. The twelfth expandable fusion device **1000n** comprises a proximal wedge **550n**, which is identical to the proximal wedge **550a** with the following exceptions. The proximal wedge **550n** (shown in **FIGS. 69A** and **69B**) includes side apertures **570n** and **572n** that are generally circular in cross-section, do not break through the side walls of the wedge (although in other embodiments they may break out), and angle toward the midline of the proximal wedge **550n**. The proximal wedge **550n** further

includes a stepped central aperture **568n**, which further includes a through hole **568n1** and a blind bore **568n2** proximate the first end **562n**, whereas the blind bore **568n2** includes a threaded section proximate the first end **562**. The proximal wedge **550n** does not include channels **598a** and **599a**, which are present in the proximal wedge **550a**.

[0351] The twelfth expandable fusion device **1000n** further comprises a distal wedge **650n** (shown in **FIGS. 70A** and **70B**), which is identical to the proximal wedge **550n** with the following exceptions. The distal wedge **650n** does not include a central aperture and instead includes a threaded blind bore **668n** through the second end **660n**, which is generally aligned with the central aperture **568n** of the proximal wedge **550n**. The distal wedge **650n** further includes a relief groove **662n1** proximate the first end **662n** intended to compensate for the thickness of a tension member looped around the wedge and engaging the side apertures.

[0352] The twelfth expandable fusion device **1000n** further includes a flexible tension member **715n**, looped through the side apertures **670n** and **672n** of the distal wedge **650**, whereas the free ends of the tension member **715n** further pass through the side apertures **570n** and **572n** and extending out of the first end **562n** of the proximal wedge **550n**, whereas these free ends may then be tied or clamped or otherwise detained or coupled to an actuator of an inserter/tensioner tool (not shown). The flexible tension member **715n** may comprise a suture, tape, fiber rope, monofilament or a bundle of either of the above and may be made out of one or more of the following: polymers (e. g. UHMWPE, PET, Nylon, PEEK, Kevlar, etc.), metals (e. g. Titanium, Titanium alloys, Stainless steel, CoCrMo, etc.) or any other fiber such as for example, silk, carbon fiber, etc.

[0353] The twelfth expandable fusion device **1000n** further comprises a set screw **700n** (best seen in **FIG. 71**), which is identical to the set screw **700** described above with the following exceptions, the drive feature **708n** (which may be a hexagon, hexalobe, trilobe, square, double-square, etc.) goes all the way through the set screw and the set screw **700n** is relatively larger than the set screw **700** so as to suitably function as described below. The set screw **700n** is threaded into the threaded portion of the bore **568n2** of the proximal wedge **550n** and is configured to (when actuated or tightened) make contact with the flexible tension member **715n** as it passes through the side openings **570n** and **572n** of the proximal wedge **550n** at the pinch points indicated in **FIG. 72C**. The thru drive feature of the set screw **700n** is configured to pass a threaded shaft **840n** (first seen in **FIG. 71**, which shows the twelfth expandable fusion device **1000n** in a fully collapsed state engaged with the threaded shaft **840n** of a tensioner instrument) of a tensioner instrument (not shown in its entirety) and allow it to access the threaded hole **668n** of the distal wedge (best seen in **FIG. 72A**, which shows a section view of the twelfth

expandable fusion device **1000n** in a fully collapsed state engaged with the threaded shaft **840n** of the tensioner instrument) and further allows graft material to be delivered through it and into the interior of the device **1000n** after the device is expanded (seen in a section view of the twelfth expandable fusion device **1000n** in **FIG. 72B**), the threaded shaft **840n** withdrawn and the set screw **700n** is actuated or tightened to lock the flexible tension member **715n** by contacting it at the pinch points indicated in a section view of the twelfth expandable fusion device **1000n** in **FIG. 72C** and thereby causing the flexible tension member **715n** to hold the tension generated by the vertebral bodies applying compressive force to the endplates and thereby allowing the twelfth expandable fusion device **1000n** to remain in its expanded state.

[0354] Unlike the fusion third expandable fusion device **1000b**, the twelfth expandable fusion device **1000n** does not comprise the actuator **500a**, instead, the functionality of the threaded (or more generally – linear) actuator **500a** of effecting the expansion of the fusion device **1000n** and keeping the twelfth expandable fusion device **1000n** at the desired state of expansion is split between the threaded shaft **840n** of the tensioner instrument (not shown here in its entirety), which threads into the distal wedge **650n** and has linear tension applied to it by the tensioner instrument while the body of said tensioner instrument simultaneously bears on the proximal wedge **550n** to cause the proximal and distal wedges **550n** and **650n** to move toward each other causing the twelfth expandable fusion device **1000n** to expand in a manner described above for other embodiments of the device, and the flexible tension member **715n** which, being attached to the tensioner instrument during the device expansion allows to keep the twelfth expandable fusion device **1000n** in the desired state of expansion by means of tightening the set screw **700n**. It should be understood that the tension member **715n** may also be locked by means other than the set screw **700n**, including tying the ends of the tension member into a knot or employing other means of preventing loss of tension or slippage of the tension member such as those widely understood, known and utilized in the designs of suture anchors and buttons used in orthopedic surgery. The ends of the tension member **715n** may need to be trimmed off following the expansion and locking step.

[0355] It should also be understood that although the various alternative geometries of the various components are presented here as discrete embodiments, these alternative embodiments have optional features which may be substituted or mixed/matched with any other embodiment in the specification. It should also be understood that substituting any of the aforementioned optional alternative features in any of the components may or will necessitate the mating components to use the inverse or complementary geometry of those features for proper engagement and that the shape of that inverse or complementary geometry would follow

inevitably from the optional alternative feature geometry described above and from the detailed description of the embodiments described as utilizing that geometry. As an example, the twelfth expandable fusion device **1000n** may utilize some or any of the actuator embodiments, height and width expansion features, configurations and embodiments as well as the endplate stabilization features and embodiments described here.

Thirteenth Expandable Fusion Device

[0356] With reference to **FIGS. 73A-74B**, **FIGS. 73A**, **73B**, **73C** and **73D** show respectively an initial collapsed state, a fully width expanded state, a fully height expanded state and an exploded view of an exemplary thirteenth expandable fusion device fusion device **1000p** comprising the endplates **100a**, **150a**, **200a** and **250a** (which are all identical in this embodiment), ramps **300p**, **350p**, **400p** and **450p** (which are all identical in this embodiment), proximal wedge **550p**, distal wedge **650p** (distal and proximal wedges are identical in this embodiment) and the actuator **500a**. The thirteenth expandable fusion device fusion device **1000p** is identical to the second expandable fusion device fusion device **1000a** described above with the following exceptions. The ramp **300p** is identical to the ramp **300a** described above with the exception that surfaces **320p**, **329p** and **330p** are not ramped but are generally transverse (they are either perpendicular as shown or angled to the long axis depending on whether the mating surfaces of the particular embodiment of the wedges are perpendicular or angled with respect to the long axis of the device) to the long axis of the thirteenth expandable fusion device fusion device **1000p**. The distal wedge **650p** is identical to the distal wedge **650a** described above with the following exceptions. It should be noted that above, the distal wedge **650a** was described simply as identical to the proximal wedge **550a**, whereas the proximal wedge **550a** was described in detail. The surfaces **680p** and **682p** are not ramped with respect to each other as the corresponding surfaces of the wedge **650a** are, but are instead generally parallel and generally transverse (Optionally, in any embodiment, they are either perpendicular as shown or angled with respect to the long axis of the device) to the long axis of the thirteenth expandable fusion device fusion device **1000p**. The surfaces **680p** and **682** further include slots **691p** and **692p** respectively, which break through one side of the wedge, but not the other side of the wedge and serve the purpose of limiting the translation of the ramps relative to the wedge on the side where the slots don't break through the side wall of the wedge **650p**. To limit the translation of the ramps relative to the wedge on the other side of the wedge, the opening of the slots may be plastically deformed or "swaged" after the device is assembled to prevent disassembly. Furthermore, the upper and lower surfaces **652p** and **690p** of the distal wedge **650p** do not

include projections or channels as they do in wedge **650a**. Distal wedge **650p** is identical to the proximal wedge **550p**.

[0357] Since the mating sliding surfaces of the ramps and their respective mating wedges are generally collectively parallel and transverse (perpendicular as shown or could be angled) to the long axis of the thirteenth expandable fusion device fusion device **1000p**, this arrangement causes the thirteenth expandable fusion device fusion device **1000p** to not be able to expand in width when the actuator **500a** is actuated. Instead, when the actuator **500a** is actuated, the device **1000p** only expands in height, which is different from the way all of the previously described embodiments behave. Since the mating sliding surfaces of the ramps and the wedges are collectively parallel and are transverse to the long axis, the thirteenth expandable fusion device fusion device **1000p** are expanded in width by means of application of external force, for example, by means of an inserter/expander instrument. As such, the articulations between the ramps and the wedges no longer act as an expansion mechanism, but simply keep the device's components in proper alignment while preventing disassembly at the upper limit of width expansion affected by the instrument. The width expansion is now independent from the height expansion, which is beneficial in some applications. **FIGS. 74A** and **74B** show the thirteenth expandable fusion device fusion device **1000p** assembled with inserter-expander instrument **840p** in respectively the initial collapsed state and in the fully width expanded state. The inserter-expander instrument **840p** (not shown in its entirety) comprises a pair of front wedges **840p1** and a pair of rear wedges **840p2**, which are drawn together or forced apart using a screw-operated, grip-operated or any other mechanism (not shown). The inserter-expander instrument is engaged with the thirteenth expandable fusion device fusion device **1000p** in a fully width expanded state of the device; the device is then collapsed back to its initial state for insertion. Once inserted into the disc-space, the front wedges and the rear wedges of the instrument are drawn together causing the thirteenth expandable fusion device fusion device **1000p** to expand in width up an expansion width at which, the front wedges no longer make contact with the device **1000p** (state best seen in **FIG. 74B**) and are withdrawn. Once that happens, the device is expanded in height. This arrangement means that in order for the instrument **840p** to be disengaged from the thirteenth expandable fusion device fusion device **1000p**, the device has to be sufficiently expanded in width to allow the front wedge to be withdrawn. Optionally, in any embodiment, multiple different front wedge widths may be supplied to the end-user to allow them to make a determination of what target expansion width is best suited for a particular application. It should be noted that having the width expansion operated by two opposing wedges does not allow to decrease the width from wider to narrower state without a dove-tail,

hook or otherwise articulation between the front and rear wedges and the device, which would allow the instrument to exert both tension and compression onto the device and thereby allow the instrument to both expand and collapse the width of the device. This functionality will be explored in embodiments below. It should also be mentioned at this point that all expansion mechanisms and configurations described above with the exception of the device **1000p** are configured (albeit with various degrees of practicality) to allow the device expansion in both width and height to be reversed by reversing the actuation direction, this is so because all of the ramped articulations described above except in the thirteenth expandable fusion device fusion device **1000p** have both the front-facing and rear-facing ramped contact surfaces allowing these articulations to take both tensile and compressive forces resulting in the ability to both expand and collapse those devices by actuating the actuators in a “forward” and “reverse” directions respectively.

[0358] It should also be understood that although the various alternative geometries of the various components are presented here as discrete embodiments, these alternative embodiments have optional features which may be substituted or mixed/matched with any other embodiment in the specification. It should also be understood that substituting any of the aforementioned optional alternative features in any of the components may or will necessitate the mating components to use the inverse or complementary geometry of those features for proper engagement and that the shape of that inverse or complementary geometry would follow inevitably from the optional alternative feature geometry described above and from the detailed description of the embodiments described as utilizing that geometry. As an example, the thirteenth expandable fusion device fusion device **1000p** may utilize some or any of the actuator embodiments, height and width expansion features, configurations and embodiments as well as the endplate stabilization features and embodiments described here.

Fourteenth Expandable Fusion Device

[0359] With reference to **FIGS. 75A-75E**, **FIGS. 75A, 75B, 75C, 75D** and **75E** show respectively an initial collapsed state, a fully width expanded state, a fully height expanded state, the fully width and height expanded state and an exploded view of an exemplary fourteenth expandable fusion device **1000r** comprising the endplates **100r, 150r, 200r** and **250r** (which are all identical in this embodiment), ramps **300r, 350r, 400r** and **450r** (which are all identical in this embodiment), proximal wedge **550p**, distal wedge **650p** (distal and proximal wedges are identical in this embodiment) and the actuator **500a**. The fourteenth expandable fusion device **1000r** is identical to the thirteenth expandable fusion device **1000p** described above with the

following exceptions. The endplate **100r** has a first end **102r** and a second end **104r**. The first endplate **100r** further comprises an upper surface **134r**, a lower surface **132r** and an inner surface **130r** connecting the first end and the second end. As in all other embodiment described here, the upper surface includes surface features increasing the roughness of the surface. The inner surface includes a cylindrical relief **149r** whose axis is parallel to the long axis. The first endplate **100** further comprises a first ramped surface **110r** proximate the first end and a second ramped surface **112r** proximate the second end. The ramped surfaces **110r** and **112r** further include dovetailed ramped slots **107r** and **109r** respectively. As discussed above, although in this embodiment, the slots are dovetailed and have generally trapezoidal cross-sections, they may also have T-shaped, Y-shaped, or any other suitable cross-section that would allow the mating articulations to possess both the leading and trailing contact surfaces. The endplate **100r** further includes an opening **119r** extending through the side surfaces in the direction transverse to the long axis. Relief **149r**. The edges formed by intersection of the ramped surfaces **110r** and **112r** and the inner surface **130r** include chamfers **121r** and **123r** configured to mate with the inserter-expander instrument **840p** described above.

[0360] The ramp **300r** is identical to the ramp **300p** described above with the following exceptions. The branches **321r** and **323r** do not have U-shaped cross-sections as the corresponding features of the ramp **300p** do, instead the branches **321r** and **323r** include ramped surfaces **302r** and **304r** respectively, whereas these ramped surfaces include dovetailed fins **302r1** and **304r1** respectively. The dovetailed fins are configured to mate with the dovetailed ramped slots of the endplates. The ramp **300r** does not include a recessed slot present in the ramp **300p**. The fourteenth expandable fusion device **1000r** has similar functionality to the thirteenth expandable fusion device **1000p** described above including the reliance on external expander instrument for width expansion.

[0361] It should also be understood that although the various alternative geometries of the various components are presented here as discrete embodiments, these alternative embodiments have optional features which may be substituted or mixed/matched with any other embodiment in the specification. It should also be understood that substituting any of the aforementioned optional alternative features in any of the components may or will necessitate the mating components to use the inverse or complementary geometry of those features for proper engagement and that the shape of that inverse or complementary geometry would follow inevitably from the optional alternative feature geometry described above and from the detailed description of the embodiments described as utilizing that geometry. As an example, the fourteenth expandable fusion device **1000r** may utilize some or any of the actuator

embodiments, height and width expansion features, configurations and embodiments as well as the endplate stabilization features and embodiments described here.

Fifteenth Expandable Fusion Device

[0362] With reference to **FIGS. 76A-76D**, **FIGS. 76A**, **76B**, **76C** and **76D** show respectively an initial collapsed state, a fully width expanded state and a fully height expanded state and an exploded view of an exemplary fifteenth expandable fusion device **1000s** comprising endplates **100r**, **150r**, **200r** and **250r** (which are all identical in this embodiment), ramps **300s**, **350s**, **400s** and **450s** (which are all identical in this embodiment), proximal wedge **550s**, distal wedge **650s** (distal and proximal wedges are identical in this embodiment) and the actuator **500a**. The fifteenth expandable fusion device **1000s** is identical to the fourteenth expandable fusion device **1000r** described above with the following exceptions. The proximal wedge **550s** is identical to the proximal wedge **550a** described above with the following exceptions, the upper and lower surfaces of the wedge **550s** include no projections or channels as they do in the wedge **550a** and the opposing ramped surfaces of the wedge **550s** have larger included angle "A" between them than they do in the wedge **550**. This angle is best seen in **FIG. 76A** and is contemplated as being greater than 100 degrees and less than 179 degrees and more preferably greater than 140 degrees and most preferably greater than 160 degrees (150 degree angle is shown for illustrative purposes). The ramp **300s** is identical to the ramp **300r** with the following exceptions: the surfaces **330s**, **320s** and **329s** are not perpendicular to the long axis as they are in the ramp **300r**, but are instead ramped at an angle equal to half of the angle "A" discussed above relative to the long axis, this is best seen in **FIG. 76A**. The ramp **300s** further includes ramped undercuts **337s1** and **337s2**, which are configured to mate with an expander instrument and may have either a rectangular section or L-shaped, T-shaped or dovetailed section. The endplate **100s** is identical to the endplate **100r** described above with the exception that the endplate **100s** also includes ramped undercuts **147s1** and **147s2**, which are configured to mate with an expander instrument and may have either a rectangular section or L-shaped, T-shaped or dovetailed section. Undercuts **337s1**, **337s2**, **147s1** and **147s2** when having rectangular sections, serve the purpose of preventing the device from expanding in height while the width expansion is affected by the expander instrument. When these undercuts have L-shaped, dovetailed or similar sections, they serve an additional purpose of allowing the expander instrument to both increase and decrease the width of the device by reversing the direction of actuation. As discussed above, this is because, the L-shaped, T-shaped, dovetailed, etc. sections contain both the front and rear contact

surfaces allowing to capture the mating components and allow tension or compression to be applied to the interface.

[0363] The significance and usefulness of the large included angle “A” between the ramped surfaces of the wedges is not obvious and requires an additional clarification. Functionality and clinical utility of many of the embodiments of the expandable fusion device described here (e. g. **1000a**, **1000b**, **1000c**, **1000d**, **1000e**, etc.) rely on the fact that complete or significant width expansion has to occur before the height expansion is initiated. This is achieved through the endplates maintaining sliding contact with mating surfaces of the wedges during width expansion step and when configured in the ways described above, this contact while maintained prevents the ramps from moving closer to each other (which would be necessary to affect height expansion). In the course of width expansion, this contact between the endplates and the wedges is eventually lost and the height expansion is allowed to start. However, the fifteenth expandable fusion device **1000s** does not include such delay mechanism, and both the width and height expansion appear to be able to occur simultaneously by turning the actuator. If we imagine an alternative fifteenth expandable fusion device **1000s1** (not shown), which is identical to the fifteenth expandable fusion device **1000s** except that its angle “A” is relatively small (e. g. around **90** degrees) and imagine this alternate fifteenth expandable fusion device **1000s1** in a state of expansion where the width of the device is less than at the state of full width expansion and where the device is at least somewhat expanded in height. If we now keep the actuator static, which it generally would be while not actuated (i. e. due to thread friction), and apply compression to the device endplates, such as the adjacent vertebral endplates would apply in clinical use, the alternate fifteenth expandable fusion device **1000s1** will tend to collapse in height and simultaneously expand in width until either the full width expansion or the full collapse of height is reached (whichever happens first based on the initial extent of height and width expansion). This happens because in any device state where full width expansion is not yet reached, for each position of the actuator relative to the wedges and consequently – for every separation distance between the proximal and the distal wedges, there exists a range of expansion states that are achievable. In other words, in this situation, the alternate fifteenth expandable fusion device **1000s1** is not at equilibrium and its height expansion are “converted” into width expansion by the following mechanism of action. In such a state, when compression is applied to the endplates in the height direction, the ramp components see a force urging them apart generated by inclined surfaces involved in height expansion, since the actuator remains static, the ramps only move apart by sliding relative to the wedges into a state of greater width expansion thereby increasing the distance between the ramps and decreasing the height of the device. In a

similar height-only or a width-only expansion mechanism, this reversal of expansion is prevented due to the friction in the threads of the actuator, which has to do with the “locking” property of threads used. Locking threads are characterized by a low “helical angle”, which for example prevents an average screw from being axially pushed into a mating thread without applying any torque (it should be noted that *no amount* of pure axial force will cause a locking thread to follow a helical path into a mating thread). This is in contrast to a non-locking (or overhauling) thread such as one used in a cork-screw, which are forced to twist into a work-piece through application of pure axial force. But in this case, since the actuator does not move, and the dis-equilibrium is intrinsic to the mechanism, the locking property of the actuator threads cannot prevent the loss of height. Similar to the threads having their mechanical efficiency controlled by angle of the thread helix (with low helical angles imparting a locking property to the threads), the ramps or “inclined planes” (of which a wedge mechanism is an adaptation) are also known to possess mechanical efficiency (or advantage), which is expressed as the length of the incline divided by its rise or more simply – by the included angle of the wedge. The larger the included angle, the less mechanical advantage the wedge mechanism has. Furthermore, for any wedge mechanism and materials used (and friction generated), there exists some maximum included angle at which the wedge will cease acting as a wedge in that attempting to push such a wedge between two objects will not cause these objects to be forced apart no matter how high the applied load is due to frictional forces, loads and material strength.

[0364] Bringing this back to the fifteenth expandable fusion device **1000s**, because the proximal and distal wedges **550s** and **650s** utilize a high angle “A”, they do not function as a width expansion mechanism and instead function as a locking mechanism preventing the fifteenth expandable fusion device **1000s** from spontaneously losing height and gaining width. This means that if in the initial collapsed state, the actuator **500** is turned, the fifteenth expandable fusion device **1000s** will only expand in height and not in width and no reasonable compressive force acting in the height direction will cause the device to lose height and gain width as discussed above. The fifteenth expandable fusion device **1000s** relies on an external inserter-expander instrument **840s** (seen in **FIGS. 77A** and **77B**) to affect the width expansion.

[0365] The inserter-expander instrument **840s** (not shown in its entirety) comprises a pair of front wedges **840s1** and a pair of rear wedges **840s2**, which are drawn together or forced apart using a screw-operated, grip-operated or any other mechanism (not shown). The instrument **840s** is configured to simultaneously actuate (here: turn) the actuator in the forward or reverse direction and translate the front and the rear wedges together or apart. Turning the actuator in the process of width expansion does not cause or substantially contribute to width expansion itself

(due to high angles “A” of the wedges and the resulting near-zero mechanical efficiency of these wedges), but simply allows the proximal and the distal wedges to move toward each other providing room for the width expansion to be effected by the forces supplied by the instrument **840s**. The inserter-expander instrument is engaged with the fifteenth expandable fusion device **1000s** in a fully width expanded state of the device, the device is then collapsed back to its initial state for insertion into the disc space (best seen in **FIG. 77A**). Once inserted into the disc-space, the front wedges and the rear wedges of the instrument are drawn together causing the fifteenth expandable fusion device **1000s** to expand in width up to an expansion width at which, the front wedges no longer make contact with the device **1000p** (state best seen in **FIG. 77B**) and are withdrawn. Once that happens, the device is expanded in height. This arrangement means that in order for the instrument **840s** to be disengaged from the device **1000p**, the device has to be sufficiently expanded in width to allow the front wedge to be withdrawn. Optionally, in any embodiment, multiple different front wedge widths may be supplied to the end-user to allow them to make a determination of what target expansion width is best suited for a particular application. It should be noted that having the width expansion operated by two opposing wedges does not allow to decrease the width from wider to narrower state unless a dove-tail, hook, L-shaped or otherwise articulation between the front and rear wedges and the device is used, which would allow the instrument to exert both tension and compression onto the device and thereby allow the instrument to both expand and collapse the width of the device as discussed above).

[0366] It should also be understood that although the various alternative geometries of the various components are presented here as discrete embodiments, these alternative embodiments have optional features which may be substituted or mixed/matched with any other embodiment in the specification. It should also be understood that substituting any of the aforementioned optional alternative features in any of the components may or will necessitate the mating components to use the inverse or complementary geometry of those features for proper engagement and that the shape of that inverse or complementary geometry would follow inevitably from the optional alternative feature geometry described above and from the detailed description of the embodiments described as utilizing that geometry. As an example, the fifteenth expandable fusion device **1000s** may utilize some or any of the actuator embodiments, height and width expansion features, configurations and embodiments as well as the endplate stabilization features and embodiments (such as shown for example in embodiments **1000c** and **1000d**) described here.

Sixteenth Expandable Fusion Device

[0367] With reference to FIGS. 78, 79A and 79B, FIG. 78 shows the initial collapsed state of an expandable device 1000t, FIG. 79A shows the initial collapsed state of an exemplary sixteenth expandable fusion device 1000t with expander instrument attached and FIG. 79B shows a width-expanded state of the device 1000t with expander instrument attached. The sixteenth expandable fusion device 1000t comprises endplates 100t, 150t (best seen in FIG. 79B), 200t and 250t (which are all identical in this embodiment), ramps 300s, 350s, 400s and 450s (which are all identical in this embodiment), proximal wedge 550s, distal wedge 650s (distal and proximal wedges are identical in this embodiment) and the actuator 500a. The sixteenth expandable fusion device 1000t is identical to the device 1000s described above with the following exceptions. The endplate 100t includes a ramped slot 107t2 formed in the upper surface 134t. This ramped slot is configured to engage the inserter-expander instrument 840t (best seen in FIGS. 79A and 79B).

[0368] The inserter-expander instrument 840t (not shown in its entirety) comprises a pair of front bifurcated ramps 840t1 which are pushed or pulled while the main body of the instrument (not shown) is attached to and bears against the proximal wedge. The instrument 840t is configured to simultaneously actuate (here: turn) the actuator in the forward or reverse direction and translate the bifurcated ramps forward or backward depending on actuation direction. Turning the actuator in the process of width expansion does not cause or substantially contribute to width expansion itself (due to high angles “A” of the wedges and the resulting near-zero mechanical efficiency of these wedges), but simply allows the proximal and the distal wedges to move toward each other providing room for the width expansion to be effected by the forces supplied by the instrument 840t. The inserter-expander instrument is engaged with the sixteenth expandable fusion device 1000t in a fully width expanded state of the device, the device is then collapsed back to its initial state for insertion into the disc space (best seen in FIG. 79A). Once inserted into the disc-space, the bifurcated ramps of the instrument are pulled toward the proximate end of the device with the main body of the instrument bearing against the proximal wedge and simultaneously turning the actuator. This causes the sixteenth expandable fusion device 1000t to expand in width up to an expansion width at which, the bifurcated ramps no longer make contact with the sixteenth expandable fusion device 1000t (state best seen in FIG. 79B) and are withdrawn. Once that happens, the device is expanded in height. This arrangement means that in order for the instrument 840t to be disengaged from the sixteenth expandable fusion device 1000t, the device has to be sufficiently expanded in width to allow the front wedge to be withdrawn. Optionally, in any embodiment, multiple different front wedge widths may be

supplied to the end-user to allow them to make a determination of what target expansion width is best suited for a particular application. Due to the fact that the bifurcated ramps of the instrument have both front and rear contact surfaces with the endplates, the width expansion process is reversible in that if actuating the instrument in one direction will cause the device to expand in width, then reversing the direction of actuation will cause the device to collapse in width.

Seventeenth Expandable Fusion Device

[0369] Now with reference to **FIG. 80**, **FIG. 80** shows a diagram of general width expansion functionality of an exemplary seventeenth expandable fusion device **1000u**, which is identical to the thirteenth expandable fusion device **1000p** described above with certain exceptions described below. The seventeenth expandable fusion device **1000u** is a modification of the thirteenth expandable fusion device **1000p** where the generally parallel articulating surfaces between the proximal wedge and its two mating ramps and between the distal wedge and its two mating ramps are inclined with respect to the long axis of the device and possesses a desirable property of allowing the device to expand in width in a non-rectilinear fashion, causing the width expanded states of the device to have a general shape of a parallelogram instead of a rectangle produced by for example the thirteenth expandable fusion device **1000p**. This is useful for some surgical approaches where the approach axis is angled with respect to standard anatomical planes such as a transforaminal (or TLIF) approach.

Eighteenth Expandable Fusion Device

[0370] Provided herein, per **FIGS. 81A-86**, is an eighteenth expandable fusion device **1000v** for implantation between two adjacent vertebrae. Optionally, in any embodiment, per **FIG. 81A** the device **1000v** comprises: an actuator **500v** comprising a drive feature **503v** and an longitudinal axis **504v**; a wedge assembly **750v** coupled to the actuator **500v**; a ramp assembly **800v** slidably coupled with the wedge assembly **750v**; an upper endplate assembly **850v** slidably coupled with the ramp assembly **800v**; and a lower endplate assembly **900v** slidably coupled with the ramp assembly **800v**.

[0371] Optionally, in any embodiment, per **FIG 81B**, the device **1000v** has a width **1100v** comprising an external width of at least one of the upper endplate assembly **850v** and the lower endplate assembly **900v**. Optionally, in any embodiment, the device has a height **1200v** comprising an external distance between the upper endplate assembly **800v** and the lower endplate assembly **900v**.

[0372] Optionally, in any embodiment, per **FIG 81C**, actuation of the drive feature **503v** by a first number of actuations in a first actuation direction **1300v** increases the width **1100v** without

increasing the height **1200v**. Optionally, in any embodiment, actuation of the drive feature **503v** by a second number of actuations beyond the first number of actuations in the first actuation direction **1300v** increases at least one of the height **1200v** and the width **1100v**. Optionally, in any embodiment, actuation of the drive feature **503v** by a second number of actuations beyond the first number of actuations in the first actuation direction **1300v** increases both the height **1200v** and the width **1100v**, wherein actuation of the drive feature **503v** by a third number of actuations beyond the second number of actuations in the first actuation direction **1300v** increases the height **1200v** without increasing the width **1100v**. Optionally, in any embodiment, actuation of the drive feature **503v** by a second number of actuations beyond the first number of actuations in the first actuation direction **1300v** increases neither the height **1200v** nor the width **1100v**, wherein actuation of the drive feature **503v** by a third number of actuations beyond the second number of actuations in the first actuation direction **1300v** increases the height **1200v** without increasing the width **1100v**. Optionally, in any embodiment, the width **1100v** of the device **1000v** reaches an apex once the drive feature **503v** is actuated by at least the first number of actuations. Optionally, in any embodiment, the height **1200v** of the device **1000v** reaches an apex once the drive feature **503v** is actuated by at least the first and second number of actuations.

[0373] Optionally, in any embodiment, actuation of the drive feature **503v** by a second number of actuations beyond the first number of actuations in the first actuation direction **1300v** increases both the height **1200v** and the width **1100v**. Optionally, in any embodiment, actuation of the drive feature **503v** by a second number of actuations beyond the first number of actuations in the first actuation direction increases the height **1200v** without increasing the width **1100v**.

[0374] Optionally, in any embodiment, actuation of the drive feature **503v** in the first actuation direction **1300v** by at least the first number of actuations increases the height **1200v** of the device **1000v** by about 30 % to about 400 %. Optionally, in any embodiment, actuation of the drive feature **503v** in the first actuation direction **1300v** by at least the first and the second number of actuations increases the width **1100v** of the device **1200v** by about 14 % to about 150 %.

[0375] Optionally, in any embodiment, per FIG. 82, the actuator **500v** comprises a cylindrically shaped elongate shaft with a distal end and a proximal end. Optionally, in any embodiment, at least a portion of the distal end comprises a first thread feature **501v**. Optionally, in any embodiment, at least a portion of the proximal end comprises a second thread feature **502v**, and wherein the proximal end comprises the drive feature **503v**. Optionally, in any embodiment, at least one of the first thread feature **501v** and the second thread feature **502v** comprise a thread disposed externally around the actuator **500v**. Optionally, in any embodiment, the first thread feature **501v** and the second thread feature **502v** have opposing threading directions. Optionally,

in any embodiment, the first thread feature **501v** and the second thread feature **502v** have the same threading direction. Optionally, in any embodiment, at least one of the first thread feature **501v** and the second thread feature **502v** comprises a right-handed threading. Optionally, in any embodiment, at least one of the first thread feature **501v** and the second thread feature **502v** comprises a left-handed threading. Optionally, in any embodiment, the drive feature **503v** comprises a recessed region configured to receive a driving instrument. Optionally, in any embodiment, the recessed region comprises a slot, Phillips, pozidrive, frearson, robertson, 12-point flange, hex socket, security hex socket, star drive, security torx, ta, tri-point, tri-wing, spanner head, clutch, one-way, double-square, triple-square, polydrive, spline drive, double hex, bristol, or a pentalobe recess or any other shaped recess. Optionally, in any embodiment, the driving feature comprises a protuberance extending therefrom and configured to be coupled to a driving instrument. Optionally, in any embodiment, the protuberance comprises a hex, a hexalobular, or a square protuberance or any other shaped protuberance. Optionally, in any embodiment, the drive feature **503v** is coincident with the longitudinal axis **504v**.

[0376] Optionally, in any embodiment, per **FIG 81C**, the wedge assembly comprises a distal wedge **650v** and a proximal wedge **550v**. Optionally, in any embodiment, actuation of the drive feature in the first direction converges the distal wedge **650v** and the proximal wedge **550v** toward one another. Optionally, in any embodiment, per **FIG 83A**, the distal wedge **650v** is an isosceles trapezoid prism comprising a distal face and a proximal face. Optionally, in any embodiment, the distal wedge **650v** comprises a third thread feature **654v**. Optionally, in any embodiment, the third thread feature **654v** extends from the distal face of the distal wedge **650v**, to the proximal face of the distal wedge **650v**. Optionally, in any embodiment, the distal wedge **650v** further comprises one or more features configured for temporary attachment to an inserter tool. Optionally, in any embodiment, the third thread feature **654v** is threadably coupled to the second thread feature **502v** of the actuator **500v**. Optionally, in any embodiment, the distal wedge **650v** further comprises first slot **651v** and second slot **652v**. Optionally, in any embodiment, the first slot **651v** comprises an upper left first slot **651v**, an upper right first slot **651v**, a lower left first slot **651v**, and a lower right first slot **651v**. Optionally, in any embodiment, the upper left first slot **651v** and the upper right first slot **651v**, and the lower left first slot **651v** and a lower right first slot **651v** have mirrored symmetry about a sagittal plane of the distal wedge **650v**. Optionally, in any embodiment, the upper left first slot **651v** and the lower left first slot **651v**, and the upper right first slot **651v** and a lower right first slot **651v** have mirrored symmetry about a transverse plane of the distal wedge **650v**. Optionally, in any embodiment, the medial plane of each of the upper left first slot **651v**, the upper right first slot

651v, the lower left first slot **651v**, and the lower right first slot **651v** are oriented at the transverse angle from the sagittal plane of the distal wedge **650v**. Optionally, in any embodiment, at least one of the third thread feature **654v** and the fourth thread feature **554v** in the distal wedge **650v** and the proximal wedge **550v**, respectively, comprise a thread locking feature configured to prevent actuation of at least one of the third first feature **501v** and the second thread feature **502v** of the actuator **500v** in a direction opposite the first actuation direction **1300v**. Optionally, in any embodiment, the thread locking feature comprises a deformable insert, a deformable thread, a distorted thread, a flexible lip, or any combination thereof. Optionally, in any embodiment, the thread locking feature comprises a bore within at least one of the distal wedge **650v** and the proximal wedge **550v** configured to provide access to the third thread feature **654v** or the fourth thread feature **554v**, and/or which is configured to receive an insert such as a pin, a screw, a dowel, a nut, or any combination thereof to prevent actuation of the actuator **500v**.

[0377] Optionally, in any embodiment, the second slot **652v** comprises an upper left second slot **652v**, an upper right second slot **652v**, a lower left second slot **652v**, and a lower right second slot **652v**. Optionally, in any embodiment, the upper left second slot **652v** and the upper right second slot **652v**, and the lower left second slot **652v** and a lower right second slot **652v** have mirrored symmetry about a sagittal plane of the distal wedge **650v**. Optionally, in any embodiment, the upper left second slot **652v** and the lower left second slot **652v**, and the upper right second slot **652v** and a lower right second slot **652v** have mirrored symmetry about a transverse plane of the distal wedge **650v**. Optionally, in any embodiment, the medial plane of the upper left second slot **652v**, the upper right second slot **652v**, the lower left second slot **652v**, and the lower right second slot **652v** are oriented at the transverse angle from the sagittal plane of the distal wedge **650v**.

[0378] Optionally, in any embodiment, per **FIG 83B**, the proximal wedge **550v** has an isosceles trapezoid prism shape comprising a distal face and a proximal face. Optionally, in any embodiment, the proximal wedge **550v** comprises a fourth thread feature **554v**. Optionally, in any embodiment, the fourth thread feature **554v** extends from the distal face of the proximal wedge **550v**, to the proximal face of the proximal wedge **550v**. Optionally, in any embodiment, the proximal wedge **550v** further comprises one or more features configured for temporary attachment to an inserter tool. Optionally, in any embodiment, the fourth thread feature **554v** is threadably coupled to the first thread feature **501v** of the actuator **500v**. Optionally, in any embodiment, the third thread feature **654v** comprises a thread disposed internally within the distal wedge **650v**. Optionally, in any embodiment, the fourth thread feature **554v** comprises a

thread disposed internally within the proximal wedge **650v**. Optionally, in any embodiment, the third thread feature **654v** and the fourth thread feature **554v** have opposing threading directions. Optionally, in any embodiment, the third thread feature **654v** and the fourth thread feature **554v** have the same threading direction. Optionally, in any embodiment, at least one of the third thread feature **654v** and the fourth thread feature **554v** comprises a right-handed threading. Optionally, in any embodiment, at least one of the third thread feature **654v** and the fourth thread feature **554v** comprises a left-handed threading.

[0379] Optionally, in any embodiment, per **FIG. 81C**, the ramp assembly **800v** comprises a first proximal ramp **300v**, a second proximal ramp **400v**, a first distal ramp **350v**, and a second distal ramp **450v**.

[0380] Optionally, in any embodiment, per **FIG. 84A** and **84B**, the second distal ramp **400v** comprises a rectangular prism divided into two lobes. Optionally, in any embodiment, the second distal ramp **400v** comprises a first ridge **401v**, a first protrusion **402v**, a v-slot **403v**, a third protrusion **404v**, a third ridge **405v**, and a third slot **406v**. Optionally, in any embodiment, the first ridge **401v** comprises two first ridges **401v**. Optionally, in any embodiment, the first ridge **401v** is located on the proximal end of the second distal ramp **400v**. Optionally, in any embodiment, the medial plane of the first ridge **401v** lies at the traverse angle from the medial face of the second distal ramp **400v**. Optionally, in any embodiment, the first protrusion **402v** comprises two first protrusions **402v**. Optionally, in any embodiment, the first protrusion **402v** is located on the mesial proximal corners of the second distal ramp **400v**. Optionally, in any embodiment, the v-slot **403v** comprise two v-slots **403v**. Optionally, in any embodiment, the v-slot **403v** is located on the mesial plane of the second distal ramp **400v**. Optionally, in any embodiment, the apex of the v-slot **403v** is oriented towards the distal end of the second distal ramp **400v**. Optionally, in any embodiment, the protrusion **404v** comprises two protrusions **404v**. Optionally, in any embodiment, the protrusion **404v** is located on the lower face of the distal ramp **400v**. Optionally, in any embodiment, the third ridge **405v** comprises two the third ridges **405v**. Optionally, in any embodiment, the third ridge **405v** is located on the upper surface of the second distal ramp **400v**. Optionally, in any embodiment, the medial plane of the third ridge **405v** is parallel to the mesial face of the second distal ramp **400v**. Optionally, in any embodiment, the third slot **406v** comprises two third slot **406v** comprises two the two third slots **406v**. Optionally, in any embodiment, the third slot **406v** is located on the upper surface of the second distal ramp **400v**. Optionally, in any embodiment, the medial plane of the third slot **406v** is parallel to the mesial face of the distal ramp **400v**. Optionally, in any embodiment, the first distal ramp **300v** is a mirrored equivalent of the second distal ramp **400v**.

Optionally, in any embodiment, the first distal ramp **350v** comprises a second ridge **351v**. Optionally, in any embodiment, the second ridge **351v** comprises two second ridges **351v**. Optionally, in any embodiment, the second ridge **351v** is located on the lateral side of the first distal ramp **350v**. Optionally, in any embodiment, the first distal ramp **350v** comprises a second protrusion **352v**. Optionally, in any embodiment, the second protrusion **352v** comprises two second protrusions **352v**. Optionally, in any embodiment, the second protrusion **352v** is located on the lateral proximal end of the first distal ramp **350v**. Optionally, in any embodiment, the medial plane of the second protrusion **352v** is perpendicular to the medial plane of the second ridge **351v**. Optionally, in any embodiment, the first distal ramp **350v** comprises a tongue **353v**. Optionally, in any embodiment, the tongue **353v** extends from the bottom of the distal ramp **350v** to the top of the distal ramp **350v** along the lateral proximal edge of the distal ramp **350v**. Optionally, in any embodiment, the second distal ramp **450v** is a mirrored equivalent of the first distal ramp **350v**.

Optionally, in any embodiment, the upper endplate assembly comprises a first endplate **100v** and a second endplate **250v**. Optionally, in any embodiment, the lower endplate assembly comprises a third endplate **150v** and a fourth endplate **200v**.

[0381] Optionally, in any embodiment, at least one of the first endplate **100v** and the second endplate **250v**, the third endplate **150v** and the fourth endplate **200v**, the first proximal ramp **300v** and the second proximal ramp **400v**, and the first distal ramp **350v** and the second distal ramp **450v** have mirrored equivalence. Optionally, in any embodiment, at least one of the second endplate **250v** and the fourth endplate **200v** is larger than at least one of the first endplate **100v** and the third endplate **150v**. Optionally, in any embodiment, at least one of the exterior faces of the first end plate **100v**, the second endplate **250v**, the third endplate **150v**, and the fourth endplate **200v** comprise a texture configured to grip the vertebrae. Optionally, in any embodiment, the texturing comprises a tooth, a ridge, a roughened area, a metallic coating, a ceramic coating, a keel, a spike, a projection, a groove, or any combination thereof.

[0382] Optionally, in any embodiment, per FIGS. **81A** and **81C**, the slideable coupling between at least one of the wedge assembly **750v** and the ramp assembly **800v**, the ramp assembly **800v** and the upper endplate assembly **850v**, and the ramp assembly **800v** and the lower endplate assembly **900v** is at a transverse angle from the longitudinal axis **504v**. Optionally, in any embodiment, the transverse angle is about 0 degrees to about 90 degrees.

[0383] Optionally, in any embodiment, the slideable coupling between at least one of the wedge assembly **750v** and the ramp assembly **800v**, the ramp assembly **800v** and the upper endplate assembly **850v**, and the ramp assembly **800v** and the lower endplate assembly **900v** comprises a

protrusion and a slot. Optionally, in any embodiment, the protrusion extends from at least one of the wedge assembly **750v** the ramp assembly **800v**, the upper endplate assembly **850v**, and the lower endplate assembly **900v**. Optionally, in any embodiment, the slot is disposed in at least one of the wedge assembly **750v** the ramp assembly **800v**, the upper endplate assembly **850v**, and the lower endplate assembly **900v**. Optionally, in any embodiment, the protrusion comprises a pin **600**, a ridge, a dimple, a bolt, a screw, a bearing, or any combination thereof. Optionally, in any embodiment, the slot comprises a through slot, a blind slot, a t-slot, a v-slot, a groove, or any combination thereof.

[0384] Optionally, in any embodiment, per **FIGS 81A-86B**, the slideable coupling between the wedge assembly **750v** and the ramp assembly comprises **800v** the first slot **651v** and the second slot **652v** within the distal wedge **650v**, the third slot **551v** and the fourth slot **552v** within the proximal wedge **550v**, a first protrusion **402v** and a first ridge **401v**, within the first proximal ramp **300v** and the second proximal ramp **400v**, and a second protrusion **352v**, a second ridge **351v**, and a tongue **353v** within the first distal ramp **350v** and the second distal ramp **450v**. Optionally, in any embodiment, the number of at least one of the first slots **651v**, the second slots **652v**, the third slots **551v**, the fourth slots **552v**, the first protrusions **402v**, the first ridges **401v**, the second protrusions **352v**, and the second ridges **351v** is about 1, 2, 3, 4 or more.

[0385] Optionally, in any embodiment, the slideable coupling between the proximal wedge **550v** and the first proximal ramp **300v** or the second proximal ramp **400v** comprises a slideable coupling between the third slot **551v** and the first ridge **401v**, and a slideable coupling between the fourth slot **552v** and the first protrusion **402v**.

[0386] Optionally, in any embodiment, the slideable coupling between the distal wedge **650v** and the first distal ramp **350v** or the second distal ramp **450v** comprises a slideable coupling between a first slot **651v** and a second ridge **351v**, a slideable coupling between a second slot **652v** and a second protrusion **352v**, or any combination thereof.

[0387] Optionally, in any embodiment, the second slot **652v** within distal wedge **650v** comprises a first stop **653v** to prevent the first protrusion **402v** from exiting the second slot **652v** in one direction. Optionally, in any embodiment, the fourth slot **552v** within the proximal wedge **550v** comprises a second stop **553v** to prevent the first protrusion **402v** from exiting the second slot **652v** in one direction.

[0388] Optionally, in any embodiment, the slideable coupling between the ramp assembly **800v** and the upper endplate assembly **850v** or the lower endplate assembly **900v** comprises a tongue **353v** within at least one of first distal ramp **350** and the second distal ramp **450**, and a v-slot **403v**, a third protrusion **404v**, a third ridge **405v**, and a third slot **406v** within at least one of first

proximal ramp **300** and the second proximal ramp **400**, and a dovetail slot **101v**, a fourth protrusion **102v**, a fourth slot **104v**, a fifth slot **103v** and a fourth ridge **105v** within at least one of the first endplate **100v**, the second endplate **250v**, the third endplate **150v** and the fourth endplate **200v**.

[0389] Optionally, in any embodiment, the slideable coupling between the first distal ramp **350v** or the second distal ramp **450v** and the first end plate **100v**, the second endplate **250v**, the third endplate **150v**, or the fourth endplate **200v** comprises a slideable coupling between the dovetail slot **101v** and the tongue **353v**.

[0390] Optionally, in any embodiment, the slideable coupling between the first proximal ramp **300v** or the second proximal ramp **400v** and the first end plate **100v**, the second endplate **250v**, the third endplate **150v**, or the fourth endplate **200v** comprises a slideable coupling between the v-slot **403v** and the fourth protrusion **102v**, a slideable coupling between the third protrusion **404v** and the fourth slot **104v**, a slideable coupling between the third ridge **405v** and the fifth slot **103v**, a slideable coupling between the third slot **406v** and the fourth ridge **105v**, or any combination thereof.

[0391] Optionally, in any embodiment, the fourth protrusion **102v** comprises a feature of the first end plate **100v**, the second endplate **250v**, the third endplate **150v**, or the fourth endplate **200v**. Optionally, in any embodiment, the fourth protrusion **102v** comprises a separate component that is firmly inserted into the first end plate **100v**, the second endplate **250v**, the third endplate **150v**, or the fourth endplate **200v**. Optionally, in any embodiment, the fourth protrusion **102v** comprises the pin **600v**.

[0392] Optionally, in any embodiment, the slideable coupling between the wedge assembly **750v** and at least one of the upper endplate assembly **850v** and lower endplate assembly **900v** comprises a slideable coupling between a distal chamfer **123v** and a proximal chamfer **121v** in at least one of the first end plate **100v**, the second endplate **250v**, the third endplate **150v**, and the fourth endplate **200v**, and a guide surface **621v 521v** in at least one of the distal wedge **650v** and a proximal wedge **550v**. Optionally, in any embodiment, the slideable coupling between the wedge assembly **750v** and at least one of the upper endplate assembly **850v** and lower endplate assembly **900v** prevents the height **1200v** of the device from increasing until the width **1100v** of the device's **1000v** reaches its apex.

[0393] Optionally, in any embodiment, at least one of the actuator **500v**, the wedge assembly **750v**, the ramp assembly **8000v**, the upper endplate assembly **850v**, and the lower endplate assembly **900v** comprise titanium, cobalt, stainless steel, tantalum, platinum, PEEK, PEKK, carbon fiber, barium sulfate, hydroxyapatite, a ceramic, zirconium oxide, silicon nitride, carbon,

bone graft, demineralized bone matrix product, synthetic bone substitute, a bone morphogenic agent, a bone growth inducing material, or any combination thereof.

[0394] Further provided herein, per FIG 81A, is an expandable fusion system for implantation between two adjacent vertebrae, the system comprising a collapsing tool 5000v and the eighteenth expandable fusion device 1000v. Optionally, in any embodiment, once the actuator 500v is actuated by at least the first number and the second number of actuations in a first actuation direction 1300v, such that the width 1100v and the height 1200v of the device 1000v are at their apex, actuation of the actuator 500v in a direction opposite the first actuation direction 1300v may only reduce the width 1100v, without reducing the height 1200v of the device 1000v. Optionally, in any embodiment, a collapsing tool 5000v may be employed to allow the height 1200v reduction without width 1100v reduction. Optionally, in any embodiment, the collapsing tool 5000v comprises a first prong 5001v and a second prong 5001v, wherein the first prong 5001v is configured to be inserted between the proximal wedge 550v and/or the distal wedge 650v and the first proximal ramp 300v, and wherein the second prong 5002v is configured to be inserted between the proximal wedge 550v and/or the distal wedge 650v and the second proximal ramp 400v. Optionally, in any embodiment, the first prong 5001v and the second prong 5001v have the same length. Optionally, in any embodiment, the first prong 5001v and the second prong 5001v have different lengths. Optionally, in any embodiment, the first prong 5001v and the second prong 5001v have the same thickness. Optionally, in any embodiment, the first prong 5001v and the second prong 5001v have different thicknesses.

[0395] Optionally, in any embodiment, the eighteenth expandable fusion device 1000v may further or alternatively include any features, components, or characteristics of any of the previously described expandable fusion device.

[0396] The numerical indicators for the components of the exemplary eighteenth expandable fusion device are compiled in Table 1, below.

100v	First endplate
101v	Dovetail slot
102v	Fourth protrusion
103v	Fourth slot
104v	Fifth slot
105v	Fourth ridge
150v	Third endplate
200v	Fourth endplate
250v	Second endplate
300v	First proximal ramp
350v	First distal ramp
351v	Second protrusion

352v	Second ridge
353v	Tongue
400v	Second proximal ramp
401v	First ridge
402v	First protrusion
403v	V-slot
404v	Third protrusion
405v	Third ridge
406v	Third slot
450v	Second distal ramp
500v	Actuator
501v	First thread feature
502v	Second thread feature
503v	Drive feature
504v	Longitudinal axis
550v	Proximal wedge
551v	Third slot
552v	Fourth slot
553v	Second Stop
554v	Fourth thread feature
600v	Pin
650v	Distal wedge
651v	First slot
652v	Second slot
653v	First Stop
654v	Third thread feature
750v	Wedge assembly
800v	Ramp assembly
850v	Upper endplate assembly
900v	Lower endplate assembly
1000v	Eighteenth Device
1100v	Width
1200v	Height
1300v	Axis of actuation
5000v	Inserter

Table 1

Nineteenth Expandable Fusion Device

[0397] Provided herein, per **FIGS. 87A-94D**, is a nineteenth expandable fusion device **1000w** for implantation between two adjacent vertebrae. Optionally, in any embodiment, per **FIG. 81A** the device **1000w** comprises: an actuator **500w** comprising a drive feature **503w** and an longitudinal axis **504v**; a wedge assembly **750w** coupled to the actuator **500v**; a ramp assembly **800w** slidably coupled with the wedge assembly **750v**; an upper endplate assembly **850w** slidably coupled with the ramp assembly **800v**; and a lower endplate assembly **900w** slidably

coupled with the ramp assembly **800w**. Optionally, in any embodiment, the upper endplate assembly **850w** is further slidably coupled with the lower endplate assembly **900w**.

[0398] Optionally, in any embodiment, per **FIG 87A**, the device **1000w** has a width **1100w** comprising an external width of at least one of the upper endplate assembly **850w** and the lower endplate assembly **900w**. Optionally, in any embodiment, the device has a height **1200w** comprising an external distance between the upper endplate assembly **800w** and the lower endplate assembly **900w**.

[0399] Optionally, in any embodiment, per **FIG 87C**, actuation of the drive feature **503w** by a first number of actuations in a first actuation direction **1300w** increases the width **1100w** without increasing the height **1200w**. Optionally, in any embodiment, actuation of the drive feature **503w** by a second number of actuations beyond the first number of actuations in the first actuation direction **1300w** increases the height **1200w** without increasing the width **1100w**. Optionally, in any embodiment, actuation of the drive feature **503w** by a second number of actuations beyond the first number of actuations in the first actuation direction **1300w** increases both the height **1200w** and the width **1100w**, wherein actuation of the drive feature **503w** by a third number of actuations beyond the second number of actuations in the first actuation direction **1300w** increases the height **1200w** without increasing the width **1100w**. Optionally, in any embodiment, actuation of the drive feature **503w** by a second number of actuations beyond the first number of actuations in the first actuation direction **1300w** increases neither the height **1200w** nor the width **1100w**, wherein actuation of the drive feature **503w** by a third number of actuations beyond the second number of actuations in the first actuation direction **1300w** increases the height **1200w** without increasing the width **1100w**. Optionally, in any embodiment, the width **1100w** of the device **1000w** reaches an apex once the drive feature **503w** is actuated by at least the first number of actuations. Optionally, in any embodiment, the height **1200w** of the device **1000w** reaches an apex once the drive feature **503w** is actuated by at least the first and second number of actuations.

[0400] Optionally, in any embodiment, actuation of the drive feature **503w** by a second number of actuations beyond the first number of actuations in the first actuation direction **1300w** increases both the height **1200w** and the width **1100w**. Optionally, in any embodiment, actuation of the drive feature **503w** by a second number of actuations beyond the first number of actuations in the first actuation direction increases the height **1200w** without increasing the width **1100w**.

[0401] Optionally, in any embodiment, actuation of the drive feature **503w** in the first actuation direction **1300w** by at least the first number of actuations increases the height **1200w** of the

device **1000w** by about 30 % to about 400 %. Optionally, in any embodiment, actuation of the drive feature **503w** in the first actuation direction **1300w** by at least the first and the second number of actuations increases the width **1100w** of the device **1200w** by about 14 % to about 150 %.

[0402] Optionally, in any embodiment, per **FIG. 88**, the actuator **500w** comprises a cylindrically shaped elongate shaft with a distal end and a proximal end. Optionally, in any embodiment, at least a portion of the distal end of the actuator **500w** comprises a first thread feature **501w**. Optionally, in any embodiment, at least a portion of the proximal end of the actuator **500w** comprises a second thread feature **502w**, and wherein the proximal end comprises the drive feature **503w**. Optionally, in any embodiment, at least one of the first thread feature **501w** and the second thread feature **502w** comprise a thread disposed externally around the actuator **500w**. Optionally, in any embodiment, the first thread feature **501w** and the second thread feature **502w** have opposing threading directions. Optionally, in any embodiment, the first thread feature **501w** and the second thread feature **502w** have the same threading direction. Optionally, in any embodiment, at least one of the first thread feature **501w** and the second thread feature **502w** comprises a right-handed threading. Optionally, in any embodiment, at least one of the first thread feature **501w** and the second thread feature **502w** comprises a left-handed threading. Optionally, in any embodiment, the drive feature **503w** comprises a recessed region configured to receive a driving instrument. Optionally, in any embodiment, the recessed region comprises a slot, Phillips, pozidrive, frearson, robertson, 12-point flange, hex socket, security hex socket, star drive, security torx, ta, tri-point, tri-wing, spanner head, clutch, one-way, double-square, triple-square, polydrive, spline drive, double hex, bristol, or a pentalobe recess. Optionally, in any embodiment, the driving feature comprises a protuberance extending therefrom and configured to be coupled to a driving instrument. Optionally, in any embodiment, the protuberance comprises a hex, a hexalobular, or a square protuberance. Optionally, in any embodiment, the drive feature **503w** is coincident with the longitudinal axis **504w**.

[0403] Optionally, in any embodiment, per **FIG 87C**, the wedge assembly comprises a distal wedge **650w** and a proximal wedge **550w**. Optionally, in any embodiment, actuation of the drive feature in the first direction converges the distal wedge **650w** and the proximal wedge **550w** toward one another. Optionally, in any embodiment, per **FIG 89A-B**, the distal wedge **650w** is a crescent-shaped prism comprising a distal end, a proximal end, a top side, and a bottom side. Optionally, in any embodiment, the distal wedge **650w** comprises a third thread feature **654w**. Optionally, in any embodiment, the third thread feature **654w** extends from the distal end of the distal wedge **650w**, to the proximal end of the distal wedge **650w**. Optionally, in any

embodiment, the distal wedge **650w** further comprises one or more features configured for temporary attachment to an inserter tool. Optionally, in any embodiment, the third thread feature **654w** is threadably coupled to the second thread feature **502w** of the actuator **500w**. Optionally, in any embodiment, the distal wedge **650w** further comprises first slot **651w** and second slot **652w**. Optionally, in any embodiment, the first slot **651w** comprises an upper left first slot **651w**, an upper right first slot **651w**, a lower left first slot **651w**, and a lower right first slot **651w**. Optionally, in any embodiment, the upper left first slot **651w** and the lower left first slot **651w**, and the upper right first slot **651w** and a lower right first slot **651w** have mirrored symmetry about a transverse plane of the distal wedge **650w**. Optionally, in any embodiment, the medial plane of each of the upper left first slot **651w**, the upper right first slot **651w**, the lower left first slot **651w**, and the lower right first slot **651w** are oriented at the transverse angle from the sagittal plane of the distal wedge **650w**. Optionally, in any embodiment, the second slot **652w** comprises an upper left second slot **652w**, an upper right second slot **652w**, a lower left second slot **652w**, and a lower right second slot **652w**. Optionally, in any embodiment, the upper left second slot **652w** and the lower left second slot **652w**, and the upper right second slot **652w** and a lower right second slot **652w** have mirrored symmetry about a transverse plane of the distal wedge **650w**. Optionally, in any embodiment, the medial plane of the upper left second slot **652w**, the upper right second slot **652w**, the lower left second slot **652w**, and the lower right second slot **652w** are oriented at the transverse angle from the sagittal plane of the distal wedge **650w**. Optionally, in any embodiment, the proximal wedge **550w** is equivalent to the distal wedge **650w**. Optionally, in any embodiment, per **FIG 87C**, the sagittal plane of the distal wedge **650w** is arranged to be coplanar with the sagittal plane of the proximal wedge **550w**. Optionally, in any embodiment, per **FIG 87C**, the sagittal plane of the distal wedge **650w** is arranged to be arranged 180 degrees from the sagittal plane of the proximal wedge **550w**.

[0404] Optionally, in any embodiment, at least one of the third thread feature **654w** and the fourth thread feature **554w** in the distal wedge **650w** and the proximal wedge **550w**, respectively, comprise a thread locking feature configured to prevent actuation of at least one of the third first feature **501w** and the second thread feature **502w** of the actuator **500w** in a direction opposite the first actuation direction **1300w**. Optionally, in any embodiment, the thread locking feature comprises a deformable insert, a deformable thread, a distorted thread, a flexible lip, or any combination thereof. Optionally, in any embodiment, the thread locking feature comprises a bore within at least one of the distal wedge **650w** and the proximal wedge **550w** configured to provide access to the third thread feature **654w** or the fourth thread feature **554w**, and/or which is configured to receive an insert such as a pin, a screw, a dowel, a nut, or any combination thereof

to prevent actuation of the actuator **500w**. Optionally, in any embodiment, per **FIG. 87C**, the ramp assembly **800w** comprises a first proximal ramp **300w**, a second proximal ramp **400w**, a first distal ramp **350w**, and a second distal ramp **450w**.

[0405] Optionally, in any embodiment, per **FIG. 90A** and **90B**, the second proximal ramp **400w** generally comprises a triangular prism. Optionally, in any embodiment, the second proximal ramp **400w** comprises a first ridge **401w**, a first protrusion **402w**, a v-slot **403w**, a third protrusion **404w**, a third ridge **405w**, and a third slot **406w**. Optionally, in any embodiment, the first ridge **401w** comprises two first ridges **401w**. Optionally, in any embodiment, the medial plane of the first ridge **401w** lies at the traverse angle from the medial face of the second proximal ramp **400w**. Optionally, in any embodiment, the first protrusion **402w** comprises two first protrusions **402w**. Optionally, in any embodiment, the v-slot **403w** is located on the transverse plane of the second proximal ramp **400w**. Optionally, in any embodiment, the apex of the v-slot **403w** is oriented towards the mesial plane of the device **1000w**. Optionally, in any embodiment, the protrusion **404w** comprises two protrusions **404w**. Optionally, in any embodiment, the protrusion **404w** is located on the lower face of the distal ramp **400w**. Optionally, in any embodiment, the third ridge **405w** comprises two the third ridges **405w**. Optionally, in any embodiment, the third ridge **405w** is located on the lower surface of the second proximal ramp **400w**. Optionally, in any embodiment, the medial plane of the third ridge **405w** is parallel to the mesial face of the second proximal ramp **400w**. Optionally, in any embodiment, the third slot **406w** comprises two third slot **406w** comprises two the two third slots **406w**. Optionally, in any embodiment, the third slot **406w** is located on the upper surface of the second proximal ramp **400w**. Optionally, in any embodiment, the medial plane of the third slot **406w** is parallel to the mesial face of the distal ramp **400w**. Optionally, in any embodiment, the second proximal ramp **300w** is equivalent to the first distal ramp **350w**.

[0406] Optionally, in any embodiment, per **FIG. 91A** and **91B**, the first proximal ramp **300w** generally comprises a triangular prism. Optionally, in any embodiment, the second distal ramp **300w** comprises a first ridge **301w**, a first protrusion **302w**, a v-slot **303w**, a third protrusion **304w**, a third ridge **305w**, and a third slot **306w**. Optionally, in any embodiment, the first ridge **301w** comprises two first ridges **301w**. Optionally, in any embodiment, the medial plane of the first ridge **301w** lies at the traverse angle from the medial face of the second distal ramp **300w**. Optionally, in any embodiment, the first protrusion **302w** comprises two first protrusions **302w**. Optionally, in any embodiment, the v-slot **303w** is located on the transverse plane of the second distal ramp **300w**. Optionally, in any embodiment, the apex of the v-slot **303w** is oriented towards the mesial plane of the device **1000w**. Optionally, in any embodiment, the protrusion

304w comprises two protrusions **304w**. Optionally, in any embodiment, the protrusion **304w** is located on the lower face of the distal ramp **300w**. Optionally, in any embodiment, the third ridge **305w** comprises two the third ridges **305w**. Optionally, in any embodiment, the third ridge **305w** is located on the lower surface of the second distal ramp **300w**. Optionally, in any embodiment, the medial plane of the third ridge **305w** is parallel to the mesial face of the second distal ramp **300w**. Optionally, in any embodiment, the third slot **306w** comprises two third slot **306w** comprises two the two third slots **306w**. Optionally, in any embodiment, the third slot **306w** is located on the upper surface of the second distal ramp **300w**. Optionally, in any embodiment, the medial plane of the third slot **306w** is parallel to the mesial face of the distal ramp **300w**. Optionally, in any embodiment, the first proximal ramp **300w** is equivalent to the second distal ramp **450w**.

[0407] Optionally, in any embodiment, the upper endplate assembly comprises a first endplate **100w** and a second endplate **250w**. Optionally, in any embodiment, the lower endplate assembly comprises a third endplate **150w** and a fourth endplate **200w**.

[0408] Optionally, in any embodiment, at least one of the first endplate **100w** and the second endplate **250w**, the third endplate **150w** and the fourth endplate **200w**, the first proximal ramp **300w** and the second proximal ramp **400w**, and the first distal ramp **350w** and the second distal ramp **450w** have mirrored equivalence. Optionally, in any embodiment, at least one of the second endplate **250w** and the fourth endplate **200w** is larger than at least one of the first endplate **100w** and the third endplate **150w**. Optionally, in any embodiment, at least one of the exterior faces of the first end plate **100w**, the second endplate **250w**, the third endplate **150w**, and the fourth endplate **200w** comprise a texture configured to grip the vertebrae. Optionally, in any embodiment, the texturing comprises a tooth, a ridge, a roughened area, a metallic coating, a ceramic coating, a keel, a spike, a projection, a groove, or any combination thereof.

[0409] Optionally, in any embodiment, per FIGS. **87A** and **87C**, the slideable coupling between at least one of the wedge assembly **750w** and the ramp assembly **800w**, the ramp assembly **800w** and the upper endplate assembly **850w**, and the ramp assembly **800w** and the lower endplate assembly **900w** is at a transverse angle from the longitudinal axis **504w**. Optionally, in any embodiment, the transverse angle is about 0 degrees to about 90 degrees.

[0410] Optionally, in any embodiment, the slideable coupling between at least one of the wedge assembly **750w** and the ramp assembly **800w**, the ramp assembly **800w** and the upper endplate assembly **850w**, and the ramp assembly **800w** and the lower endplate assembly **900w** comprises a protrusion and a slot. Optionally, in any embodiment, the protrusion extends from at least one of the wedge assembly **750w** the ramp assembly **800w**, the upper endplate assembly **850w**, and

the lower endplate assembly **900w**. Optionally, in any embodiment, the slot is disposed in at least one of the wedge assembly **750w** the ramp assembly **800w**, the upper endplate assembly **850w**, and the lower endplate assembly **900w**. Optionally, in any embodiment, the protrusion comprises a pin **600**, a ridge, a dimple, a bolt, a screw, a bearing, or any combination thereof. Optionally, in any embodiment, the slot comprises a through slot, a blind slot, a t-slot, a v-slot, a groove, or any combination thereof.

[0411] Optionally, in any embodiment, per **FIGS 87A-95B**, the slideable coupling between the wedge assembly **750w** and the ramp assembly comprises **800w** the first slot **651w** and the second slot **652w** within the distal wedge **650w**, the third slot **551w** and the fourth slot **552w** within the proximal wedge **550w**, a first protrusion **402w** and a first ridge **401w**, within the first proximal ramp **300w** and the second proximal ramp **400w**, and a second protrusion **352w**, a second ridge **351w**, and a v-slot **353w** within the first distal ramp **350w** and the second distal ramp **450w**. Optionally, in any embodiment, the number of at least one of the first slots **651w**, the second slots **652w**, the third slots **551w**, the fourth slots **552w**, the first protrusions **402w**, the first ridges **401w**, the second protrusions **352w**, and the second ridges **351w** is about 1, 2, 3, 4 or more.

[0412] Optionally, in any embodiment, the slideable coupling between the proximal wedge **550w** and the first proximal ramp **300w** or the second proximal ramp **400w** comprises a slideable coupling between the third slot **551w** and the first ridge **401w**, and a slideable coupling between the fourth slot **552w** and the first protrusion **402w**.

[0413] Optionally, in any embodiment, the slideable coupling between the distal wedge **650w** and the first distal ramp **350w** or the second distal ramp **450w** comprises a slideable coupling between a first slot **651w** and a second ridge **351w**, a slideable coupling between a second slot **652w** and a second protrusion **352w**, or any combination thereof.

[0414] Optionally, in any embodiment, the second slot **652w** within distal wedge **650w** comprises a first stop **653w** to prevent the first protrusion **402w** from exiting the second slot **652w** in one direction. Optionally, in any embodiment, the fourth slot **552w** within the proximal wedge **550w** comprises a second stop **553w** to prevent the first protrusion **402w** from exiting the second slot **652w** in one direction.

[0415] Optionally, in any embodiment, the slideable coupling between the ramp assembly **800w** and the upper endplate assembly **850w** or the lower endplate assembly **900w** comprises a tongue **353w** within at least one of first distal ramp **350** and the second distal ramp **450**, and a v-slot **403w**, a third protrusion **404w**, a third ridge **405w**, and a third slot **406w** within at least one of first proximal ramp **300** and the second proximal ramp **400**, and a dovetail slot **101w 151w 201w 251w**, a fourth protrusion **102w 152w 202w 252w**, a fifth slot **103w 153w 203w 253w**, a fourth

slot **104w 154w 204w 254w** and a fourth ridge **105w 155w 205w 255w** within at least one of the first endplate **100w**, the second endplate **250w**, the third endplate **150w** and the fourth endplate **200w**.

[0416] Optionally, in any embodiment, the slideable coupling between the first distal ramp **350w** or the second distal ramp **450w** and the first end plate **100w**, the second endplate **250w**, the third endplate **150w**, or the fourth endplate **200w** comprises a slideable coupling between the dovetail slot **101w 151w 201w 251w** and the tongue **353w**.

[0417] Optionally, in any embodiment, the slideable coupling between the first proximal ramp **300w** or the second proximal ramp **400w** and the first end plate **100w**, the second endplate **250w**, the third endplate **150w**, or the fourth endplate **200w** comprises a slideable coupling between the v-slot **403w** and the fourth protrusion **102w 152w 202w 252w**, a slideable coupling between the third protrusion **404w** and the fourth slot **104w 154w 204w 254w**, a slideable coupling between the third ridge **405w** and the fifth slot **103w 153w 203w 253w**, a slideable coupling between the third slot **406w** and the fourth ridge **105w 155w 205w 255w**, or any combination thereof.

[0418] Optionally, in any embodiment, the fourth protrusion **102w 152w 202w 252w** comprises a feature of the first end plate **100w**, the second endplate **250w**, the third endplate **150w**, or the fourth endplate **200w**. Optionally, in any embodiment, the fourth protrusion **102w 152w 202w 252w** comprises a separate component that is firmly inserted into the first end plate **100w**, the second endplate **250w**, the third endplate **150w**, or the fourth endplate **200w**. Optionally, in any embodiment, the fourth protrusion **102w 152w 202w 252w** comprises the pin **600w**.

[0419] Optionally, in any embodiment, the slideable coupling between the upper endplate assembly **850w** and the lower endplate assembly **900w** comprises a slideable coupling between a tongue **101w** in the first endplate **100w** and a groove **151w** in the third endplate **150w**, and a slideable coupling between a tongue **251w** in the second endplate **250w** and a groove **201w** in the fourth endplate **200w**.

[0420] Optionally, in any embodiment, the slideable coupling between the wedge assembly **750w** and at least one of the upper endplate assembly **850w** and lower endplate assembly **900w** comprises a slideable coupling between a distal chamfer **123w** and a proximal chamfer **121w** in at least one of the first end plate **100w**, the second endplate **250w**, the third endplate **150w**, and the fourth endplate **200w**, and a guide surface **621w 521w** in at least one of the distal wedge **650w** and a proximal wedge **550w**. Optionally, in any embodiment, the slideable coupling between the wedge assembly **750w** and at least one of the upper endplate assembly **850w** and lower endplate assembly **900w** prevents the height **1200w** of the device from increasing until the width **1100w** of the device's **1000w** reaches its apex.

[0421] Optionally, in any embodiment, at least one of the actuator **500w**, the wedge assembly **750w**, the ramp assembly **8000w**, the upper endplate assembly **850w**, and the lower endplate assembly **900w** comprise titanium, cobalt, stainless steel, tantalum, platinum, PEEK, PEKK, carbon fiber, barium sulfate, hydroxyapatite, a ceramic, zirconium oxide, silicon nitride, carbon, bone graft, demineralized bone matrix product, synthetic bone substitute, a bone morphogenic agent, a bone growth inducing material, or any combination thereof.

[0422] Optionally, in any embodiment, the nineteenth expandable fusion device **1000W** may further or alternatively include any features, components, or characteristics of any of the previously described expandable fusion device.

[0423] Further provided herein, per **FIGS 96A to 97**, is an expandable fusion system for implantation between two adjacent vertebrae, the system comprising a collapsing tool **5000w** and the nineteenth expandable fusion device **1000v**. Optionally, in any embodiment, once the actuator **500w** is actuated by at least the first number and the second number of actuations in a first actuation direction **1300w** such that the width **1100w** and the height **1200w** of the device **1000w** are at their apex, actuation of the actuator **500w** in a direction opposite the first actuation direction **1300w** may only reduce the width **1100w**, without reducing the height **1200w** of the device **1000v**. Optionally, in any embodiment, a collapsing tool **5000w** may be employed to allow the height **1200w** reduction without width **1100w** reduction. Optionally, in any embodiment, the collapsing tool **5000w** comprises a first prong **5001w** and a second prong **5001w**, wherein the first prong **5001w** is configured to be inserted between the proximal wedge **550w** and/or the distal wedge **650w** and the first proximal ramp **300w**, and wherein the second prong **5002w** is configured to be inserted between the proximal wedge **550w** and/or the distal wedge **650w** and the second proximal ramp **400w**. Optionally, in any embodiment, the first prong **5001w** and the second prong **5001w** have the same length. Optionally, in any embodiment, the first prong **5001w** and the second prong **5001w** have different lengths. Optionally, in any embodiment, the first prong **5001w** and the second prong **5001w** have the same thickness. Optionally, in any embodiment, the first prong **5001w** and the second prong **5001w** have different thicknesses.

[0424] The numerical indicators for the components of the exemplary nineteenth expandable fusion device are compiled in Table 2, below.

100w	First endplate
101w	Dovetail slot
102w	Fourth protrusion
103w	Fourth slot
104w	Fifth slot

105w	Fourth ridge
150w	Third endplate
200w	Fourth endplate
250w	Second endplate
300w	First proximal ramp
350w	First distal ramp
351w	Second protrusion
352w	Second ridge
353w	Tongue
400w	Second proximal ramp
401w	First ridge
402w	First protrusion
403w	V-slot
404w	Third protrusion
405w	Third ridge
406w	Third slot
450w	Second distal ramp
500w	Actuator
501w	First thread feature
502w	Second thread feature
503w	Drive feature
504w	Longitudinal axis
550w	Proximal wedge
551w	Third slot
552w	Fourth slot
553w	Second Stop
554w	Fourth thread feature
600w	Pin
650w	Distal wedge
651w	First slot
652w	Second slot
653w	First Stop
654w	Third thread feature
750w	Wedge assembly
800w	Ramp assembly
850w	Upper endplate assembly
900w	Lower endplate assembly
1000w	Eighteenth Device
1100w	Width
1200w	Height
1300w	Axis of actuation
5000w	Insertor

Table 2

Twentieth Expandable Fusion Device

[0425] Provided herein, per **FIGS. 98A-B**, is a twentieth expandable fusion device **1000x** for implantation between two adjacent vertebrae. Optionally, in any embodiment, per **FIG. 95a** the device **1000x** comprises: an actuator **500x** comprising a drive feature **503x** and an longitudinal axis **504x**; a wedge assembly **750x** coupled to the actuator **500x**; a ramp assembly **800x** slidably coupled with the wedge assembly **750x**; an upper endplate assembly **850x** slidably coupled with the ramp assembly **800x**; and a lower endplate assembly **900x** slidably coupled with the ramp assembly **800w**.

[0426] Optionally, in any embodiment, at least one of the actuator **500w**, the wedge assembly **750x**, the ramp assembly **8000x**, the upper endplate assembly **850x**, and the lower endplate assembly **900x** comprise titanium, cobalt, stainless steel, tantalum, platinum, PEEK, PEKK, carbon fiber, barium sulfate, hydroxyapatite, a ceramic, zirconium oxide, silicon nitride, carbon, bone graft, demineralized bone matrix product, synthetic bone substitute, a bone morphogenic agent, a bone growth inducing material, or any combination thereof.

[0427] Optionally, in any embodiment, the twentieth expandable fusion device **1000x** can further or alternatively include any features, components, or characteristics of any of the previously described expandable fusion device.

Twenty-First Expandable Fusion Device

[0428] Provided herein, per **FIG. 99**, is a twenty-first expandable fusion device **1000y** for implantation between two adjacent vertebrae. Optionally, in any embodiment, per **FIG. 95a** the device comprises: an actuator comprising a drive feature and an longitudinal axis; a wedge assembly coupled to the actuator; a ramp assembly slidably coupled with the wedge assembly; an upper endplate assembly slidably coupled with the ramp assembly; and a lower endplate assembly slidably coupled with the ramp assembly. Optionally, in any embodiment, the twenty-first expandable fusion device **1000y** comprises a gap **101y** between at least one of the upper endplate assembly and the lower endplate assembly, and at least one of the proximal wedge and the distal wedge. Optionally, in any embodiment, the gap **101y** enables the device **1000y** to expand in width and height simultaneously.

[0429] Optionally, in any embodiment, at least one of the actuator , the wedge assembly , the ramp assembly , the upper endplate assembly , and the lower endplate assembly comprise titanium, cobalt, stainless steel, tantalum, platinum, PEEK, PEKK, carbon fiber, barium sulfate, hydroxyapatite, a ceramic, zirconium oxide, silicon nitride, carbon, bone graft, demineralized

bone matrix product, synthetic bone substitute, a bone morphogenic agent, a bone growth inducing material, or any combination thereof.

[0430] Optionally, in any embodiment, the lack of a slideable coupling between the wedge assembly and at least one of the upper endplate assembly and lower endplate assembly allows both the height and width of the device **1000y** to increase until their relative apexes. Optionally, in any embodiment, the height and width of the **1000y** increase at the same rate when the actuator is actuated in a first direction.

[0431] Optionally, in any embodiment, actuation of the drive feature by first number of actuations in the first actuation direction increases both the height and the width of the device **1000x** at the same rate. Optionally, in any embodiment, actuation of the drive feature by first number of actuations in the first actuation direction increases both the height and the width of the device **1000x** at different rates.

[0432] Optionally, in any embodiment, the twentieth expandable fusion device **1000x** can further or alternatively include any features, components, or characteristics of any of the previously described expandable fusion device.

Terms and Definitions

[0433] Unless otherwise defined, all technical terms used herein have the same meaning as commonly understood by one of ordinary skill in the art to which this disclosure belongs.

[0434] As used herein, the singular forms “a,” “an,” and “the” include plural references unless the context clearly dictates otherwise. Any reference to “or” herein is intended to encompass “and/or” unless otherwise stated.

[0435] As used herein, the term “about” refers to an amount that is near the stated amount by 10%, 5%, or 1%, including increments therein.

[0436] As used herein, the term “longitudinal axis” refers to a theoretical axis in space comprising an axis of revolving symmetry of an object.

[0437] As used herein, the term “slidably coupled” refers to a relationship between two or more components whereby the components share at least one degree of freedom.

[0438] As used herein, the term “external width” refers to the width between the outermost surfaces of an object.

[0439] As used herein, the term “external distance” refers to the distance between the outermost surfaces of an object.

[0440] As used herein, the term “apex” refers to the maximum value of a distance, measurement, or parameter.

[0441] As used herein, the term “thread feature” refers to one or more helical or spiral protrusions or recesses capable of acting as, or coupling with another thread feature.

CLAIMS

1. An expandable device, comprising:
 - a first pair of endplates having a first upper endplate and a second upper endplate;
 - a second pair of endplates having the first upper endplate and a first lower endplate;
 - a translatable wedge configured to expand a width of the first pair of endplates; and,
 - a pair of ramps slidably coupled to the translatable wedge and configured to expand a height of the second pair of endplates; wherein,
 - a drawing of the translatable wedge using a single actuator expands the width of the first pair of endplates; and,
 - a further drawing of the translatable wedge using the single actuator expands the height of the second pair of endplates.
2. The device of claim 1, wherein the device is configured such that the drawing of the translatable wedge expands the width of the first pair of endplates without expanding the height of the second pair of endplates.
3. The device of claim 1 or claim 2, the device comprising:
 - a wedge assembly including the translatable wedge as a first wedge, the wedge assembly configured for coupling to a single actuator, the wedge assembly having the first wedge and a second wedge that are discrete from, and oppose, each other;
 - a ramp assembly including the pair of ramps and slidably coupled with the wedge assembly, the pair of ramps having a first ramp and a second ramp that are discrete from, and oppose, each other;
 - an upper endplate assembly having the first pair of endplates, the first upper endplate movable away from the second upper endplate for a width expansion stage, the upper endplate assembly slidably coupled with the first ramp and the second ramp; and,
 - a lower endplate assembly having a third pair of endplates that include the first lower endplate and a second lower endplate, the first lower endplate movable away from the second lower endplate for the width expansion stage, the lower endplate assembly slidably coupled with the first ramp and the second ramp;wherein, the device is configured for a staged expansion such that
 - the drawing of the wedges together increases the width of the device without increasing the height of the device by drawing the wedges toward each other without translating the first ramp and the second ramp toward each other; and,
 - the further drawing of the wedges together increases the height of the device by translating the first and second ramp toward each other.

4. The device of claim 3, wherein the ramp assembly comprises a first distal ramp, a second distal ramp, a first proximal ramp, and a second proximal ramp.
5. The device of claim 3 or claim 4, wherein the slideable coupling between at least one of the wedge assembly and the ramp assembly, the ramp assembly and the upper endplate assembly, and the ramp assembly and the lower endplate assembly is at a transverse angle from the longitudinal axis.
6. The device of claim 5, wherein the transverse angle is about 0 degrees to about 90 degrees.
7. The device of any one of claims 3 to 6, wherein the slideable coupling between at least one of the wedge assembly and the ramp assembly, the ramp assembly and the upper endplate assembly, and the ramp assembly and the lower endplate assembly comprises a protrusion and a slot, wherein the protrusion extends from at least one of the wedge assembly, the ramp assembly, the upper endplate assembly, and the lower endplate assembly, and wherein the slot is disposed in at least one of the upper endplate assembly, and the lower endplate assembly.
8. The device of any one of claims 3 to 7, wherein at least one of the second upper endplate and the second lower endplate is larger than at least one of the first upper endplate and the first lower endplate.
9. The device of any one of claims 3 to 8, further comprising the single actuator having a drive feature; wherein,
drawing the wedges together includes actuating the drive feature by a first number of actuations in a first actuation direction; and,
further drawing the wedges together includes actuating the drive feature in the first actuation direction by a second number of actuations beyond the first number of actuations.
10. The device of claim 9, wherein actuation of the drive feature by a second number of actuations beyond the first number of actuations in the first actuation direction increases both the height and the width.
11. The device of claim 9 or claim 10, wherein actuation of the drive feature by a third number of actuations beyond the first and second number of actuations in the first actuation direction increases the height without increasing the width.
12. The device of any one of claims 9 to 11, wherein the actuator has a distal end and a proximal end, wherein at least a portion of the distal end comprises a first thread feature, wherein at least a portion of the proximal end comprises a second thread feature, and wherein the proximal end comprises the drive feature.

13. The device of claim 12, wherein the first wedge and the second wedge are a distal wedge and a proximal wedge.
14. The device of claim 13, wherein actuation of the drive feature in the first direction converges the distal wedge and the proximal wedge toward one another.
15. An expandable fusion system for implantation between two adjacent vertebrae, the system comprising:
 - an inserter;
 - the single actuator comprising a drive feature; and,
 - the device of any one of claims 1 to 14.
16. The system of claim 15 further comprising a collapsing tool.
17. A method for implanting an expandable fusion device between two adjacent vertebrae comprising:
 - inserting the device of any one of claims 1 to 14;
 - drawing the wedges together to increase the width without increasing the height by drawing the wedges toward each other without translating the first ramp and the second ramp toward each other; and,
 - further drawing the wedges together to increase the height by translating the first and second ramp toward each other.
18. The method of claim 17, wherein the method further comprises:
 - actuating a drive feature by a first number of actuations in a first actuation direction to increase the width without increasing the height;
 - actuating the drive feature by the second number of actuations beyond the first number of actuations in the first actuation direction to increase at least one of the height and the width.
19. The method of claim 18, wherein actuation of the drive feature by a third number of actuations beyond the first and second number of actuations in the first actuation direction increases the height without increasing the width.

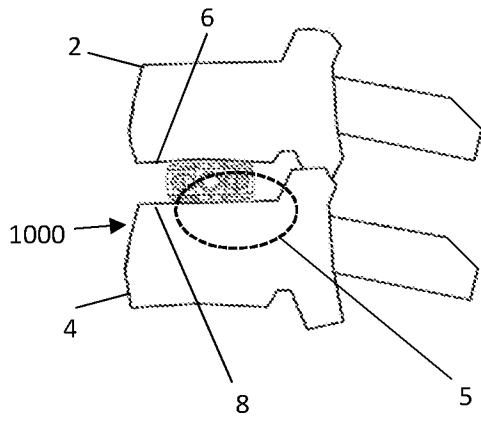

FIG. 1

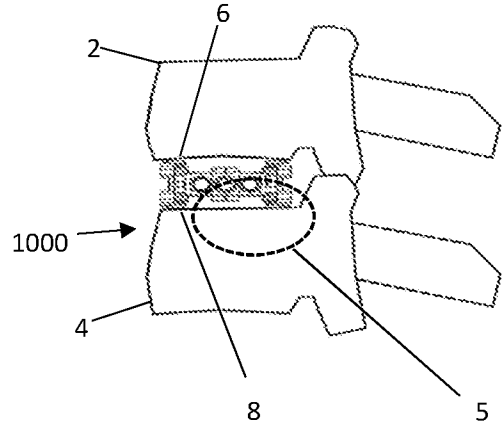

FIG. 2

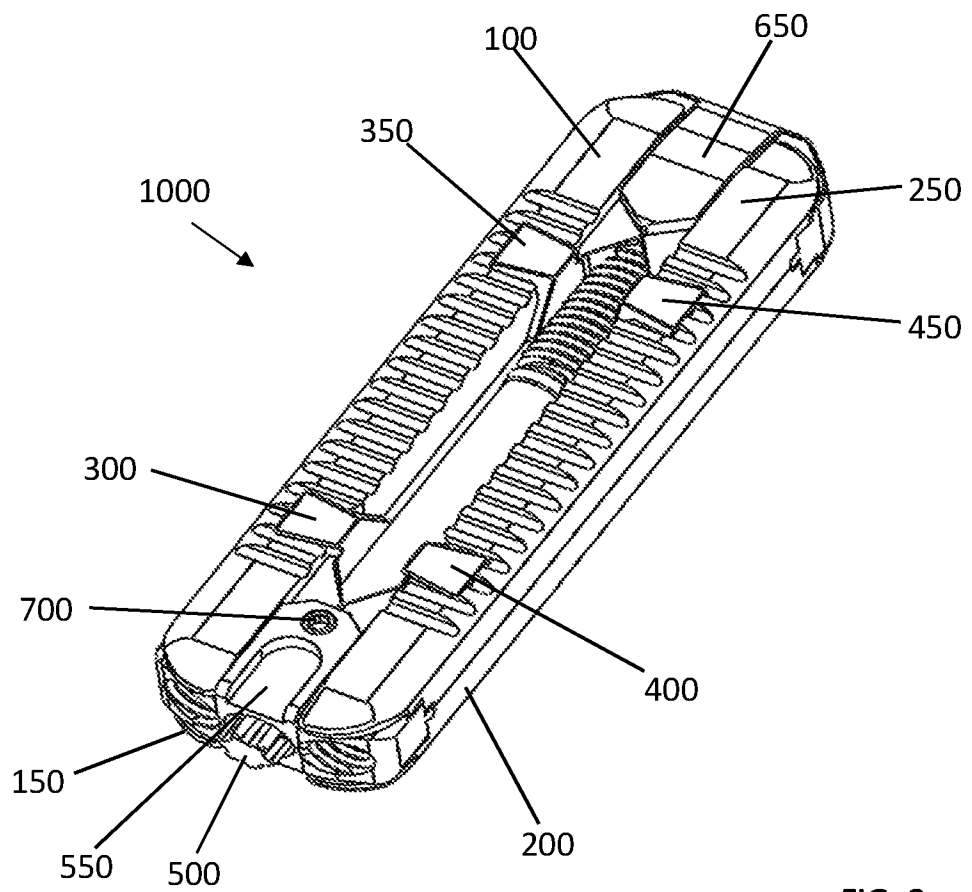

FIG. 3

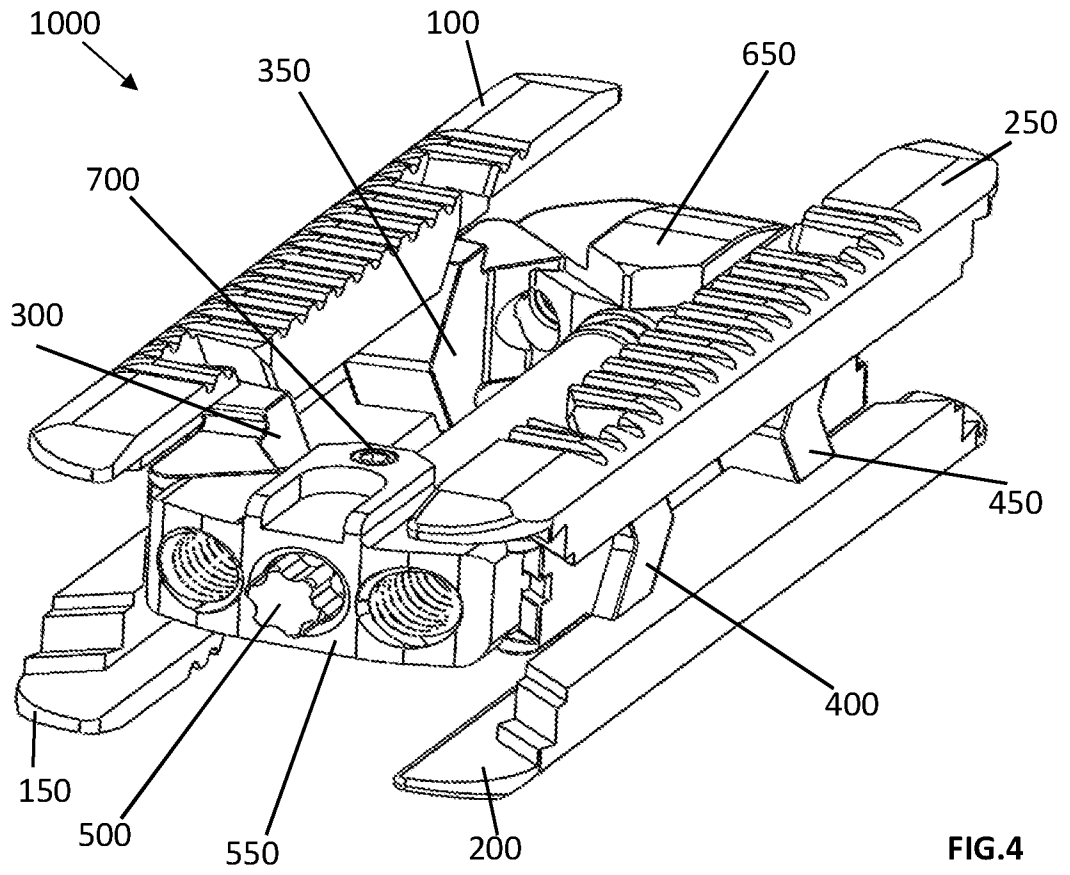

FIG.4

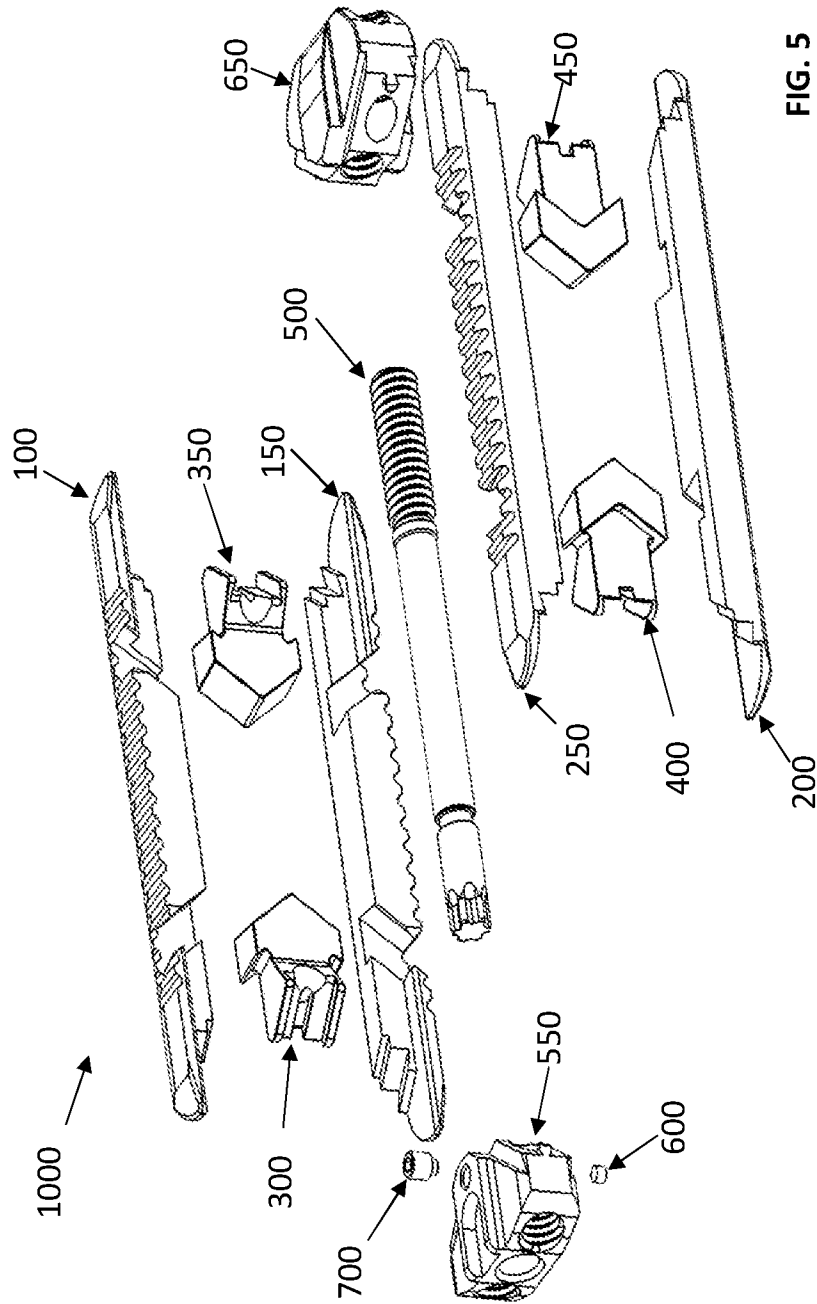

FIG. 5

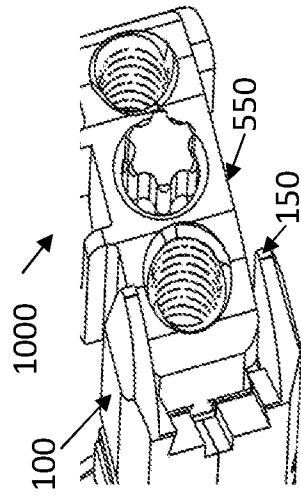

FIG. 7A

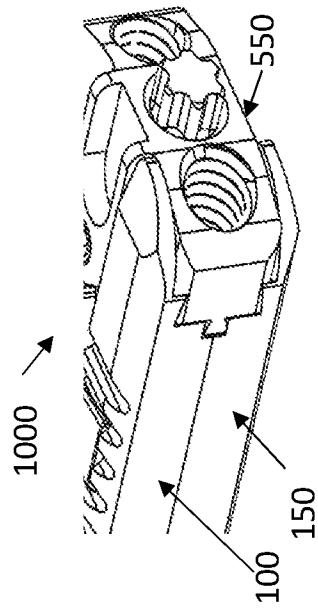

FIG. 7B

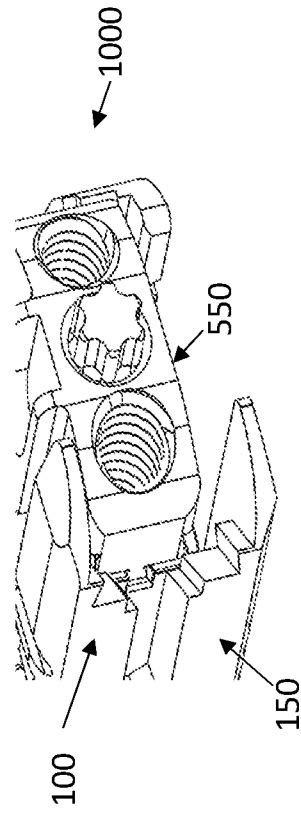

FIG. 7C

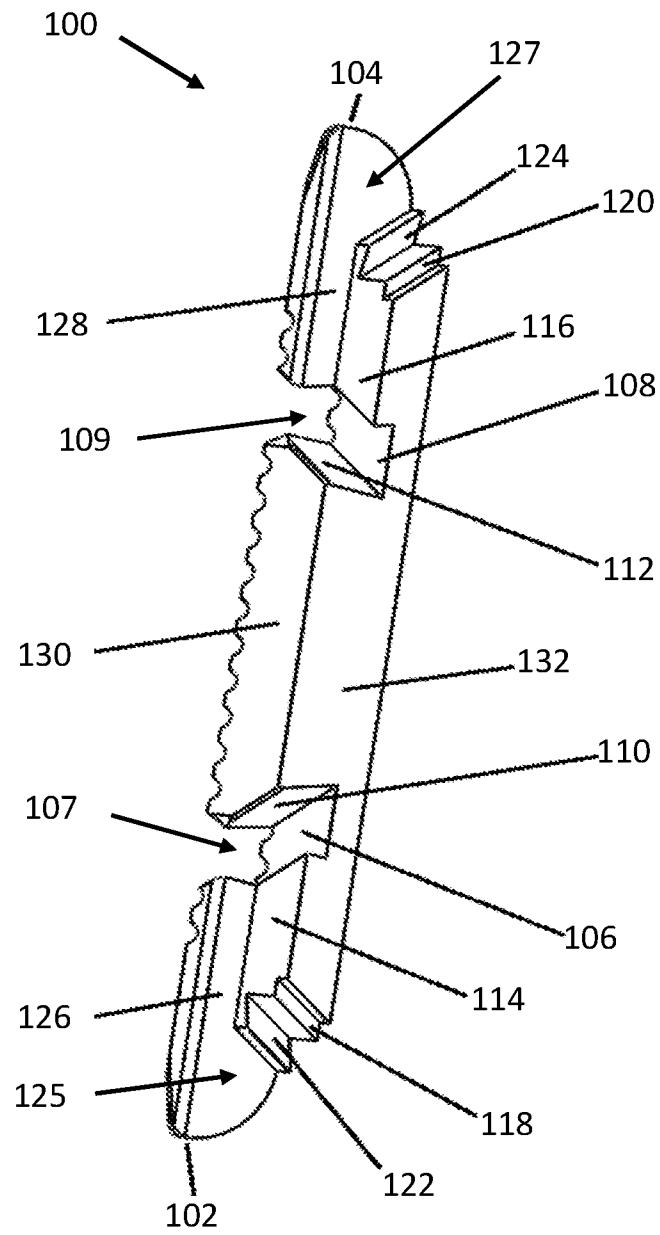

FIG. 8A

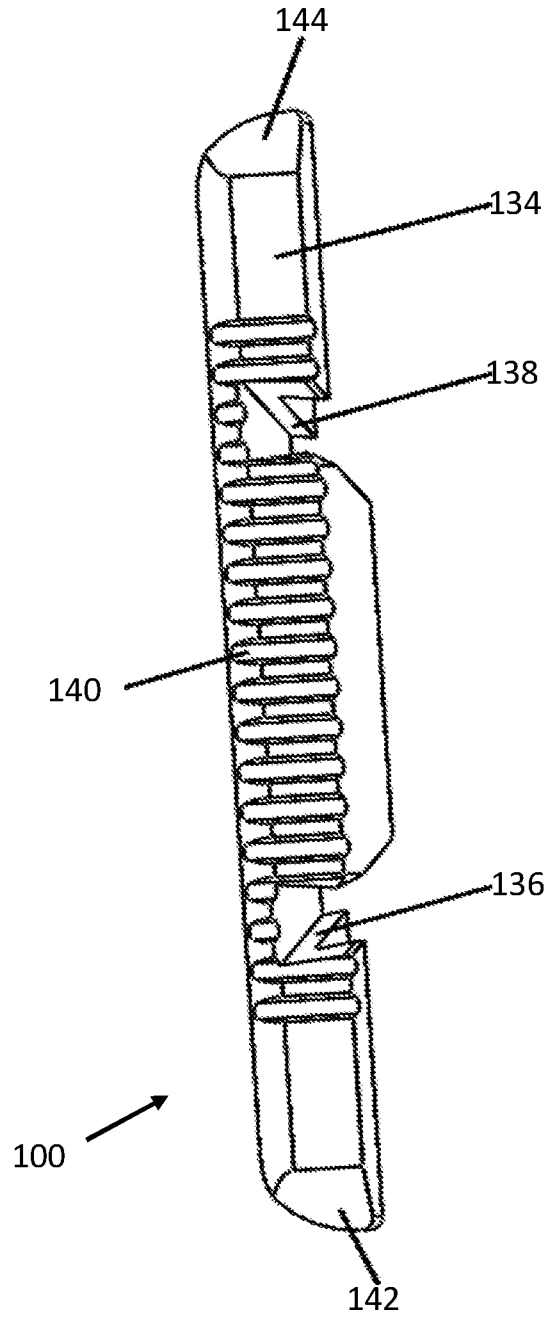
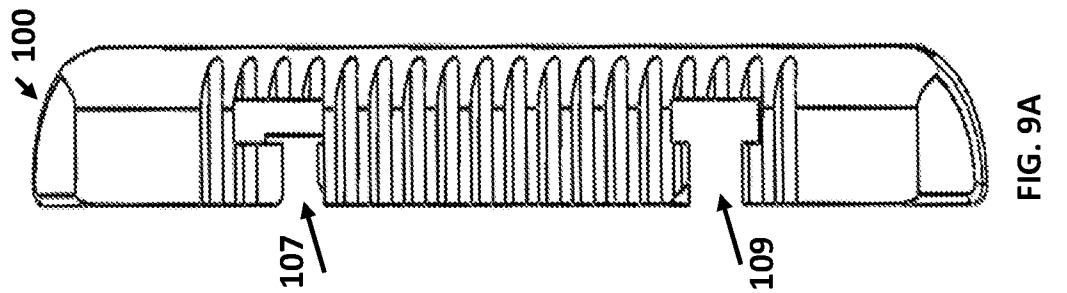
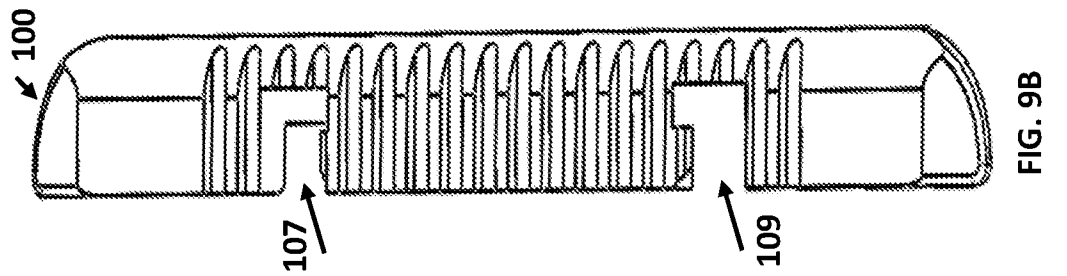
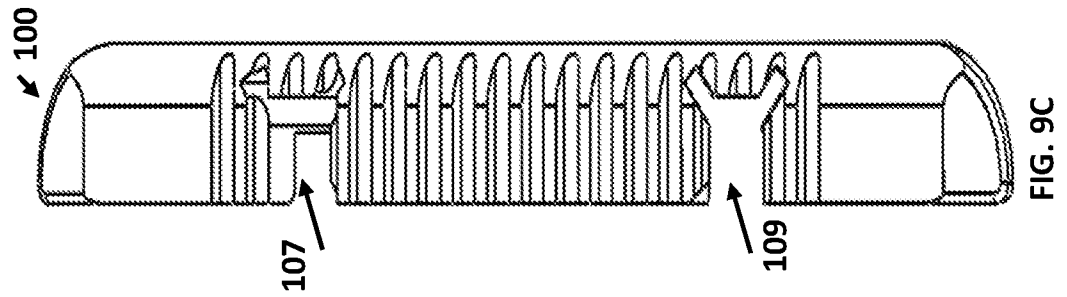
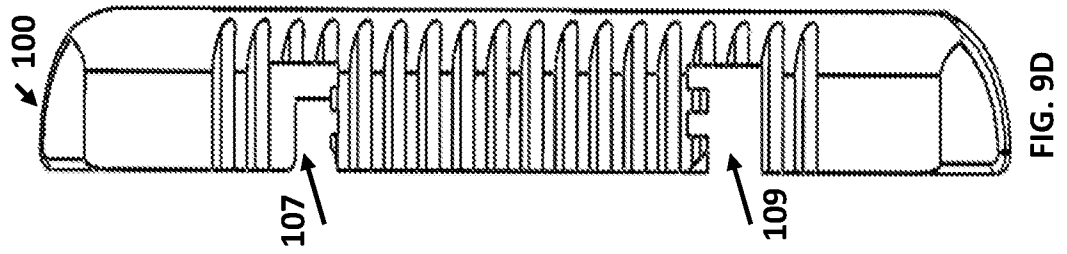

FIG. 8B



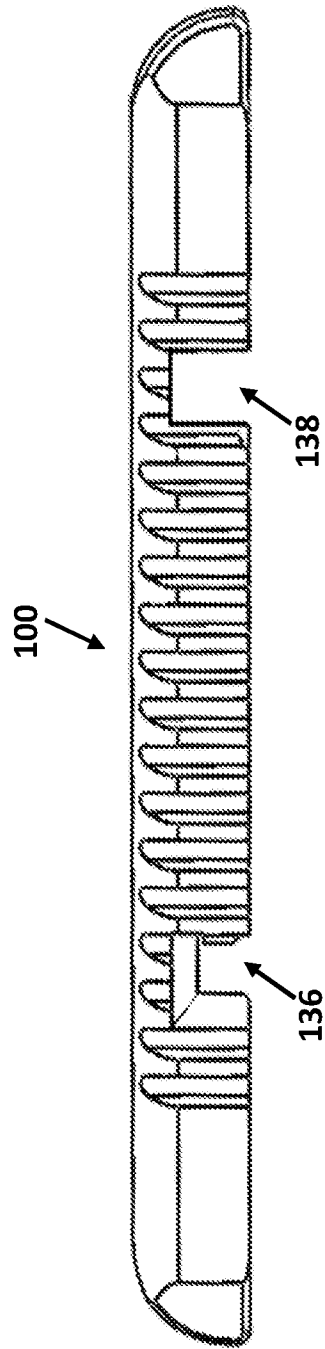

FIG. 9E

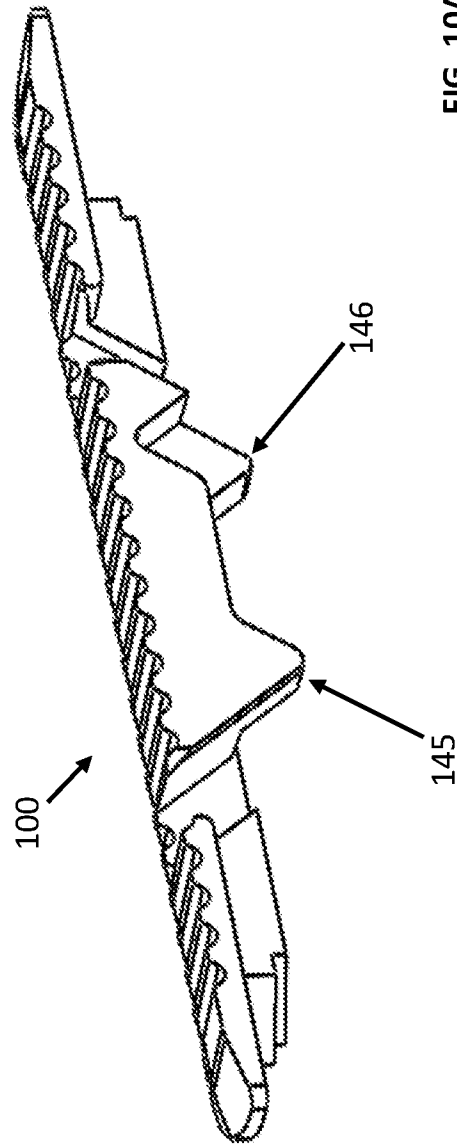

FIG. 10A

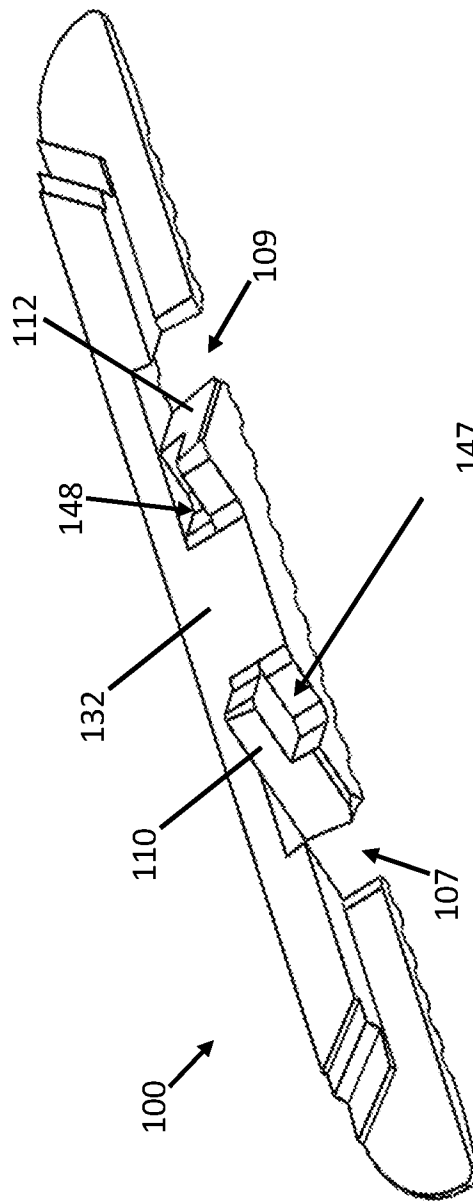

FIG. 10B

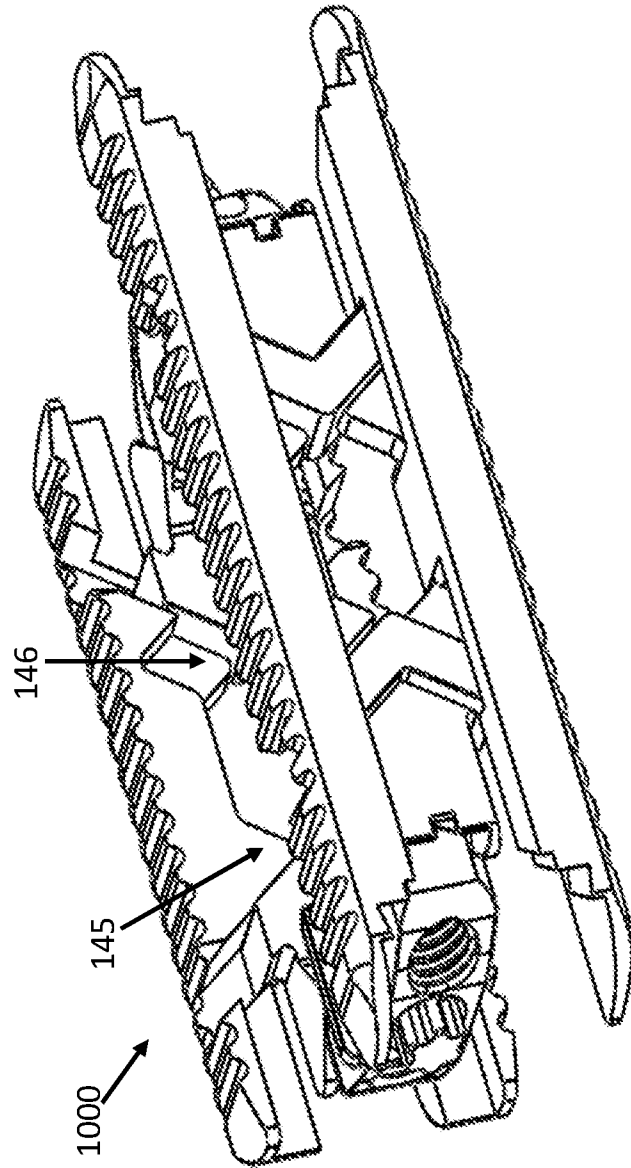

FIG. 10C

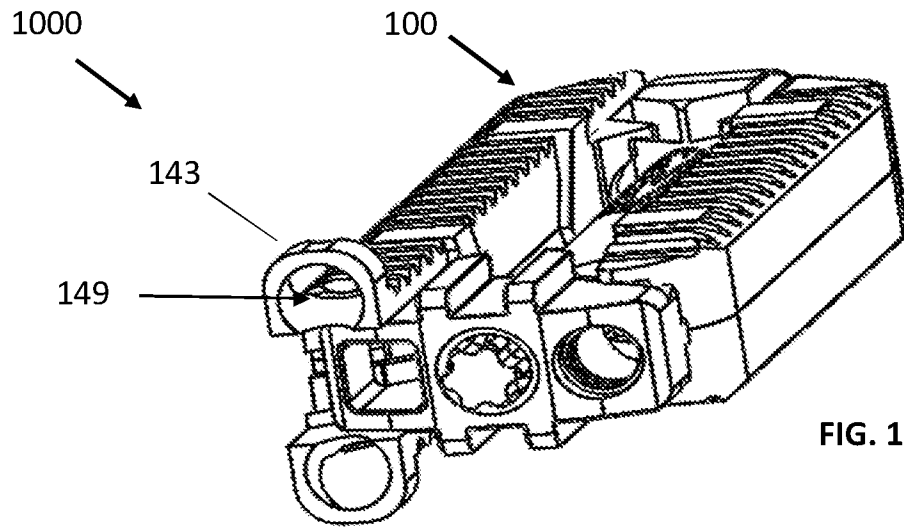

FIG. 10D1

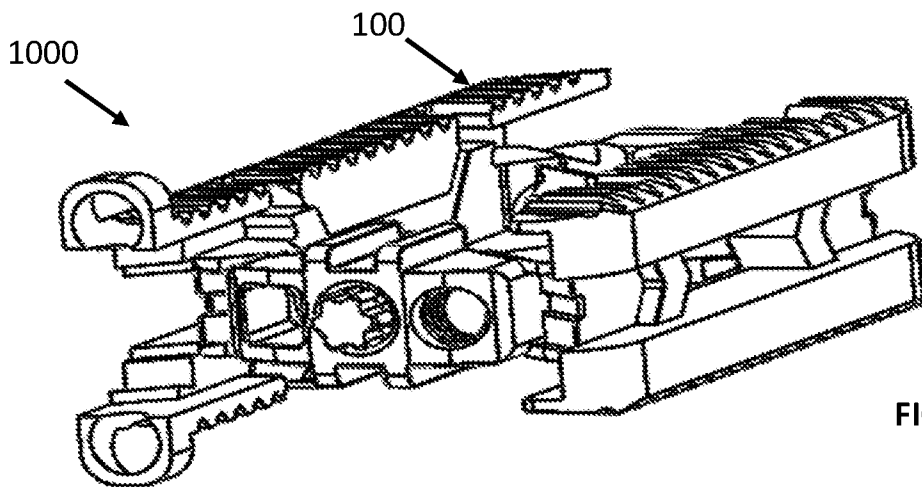

FIG. 10D2

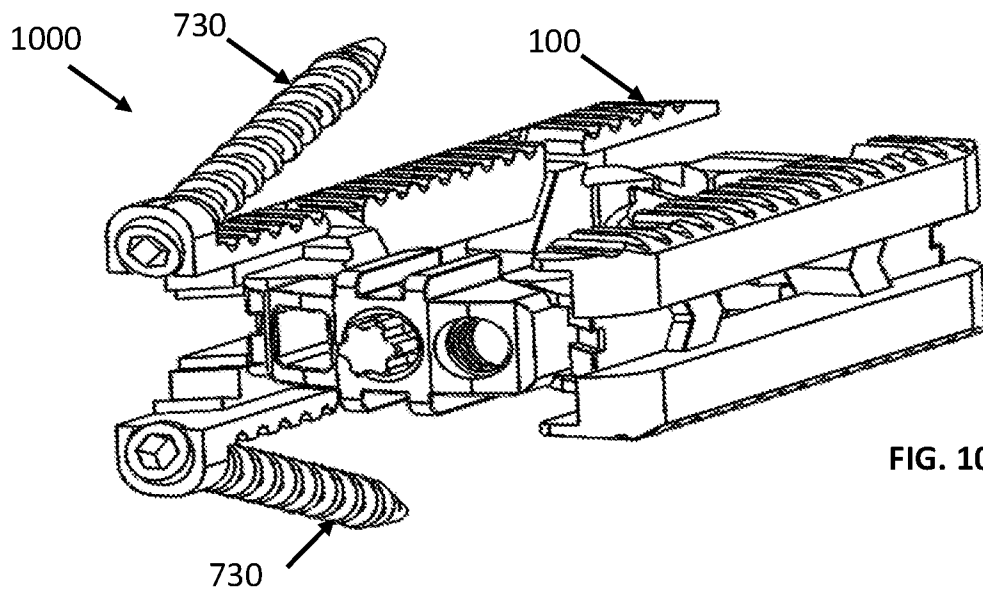
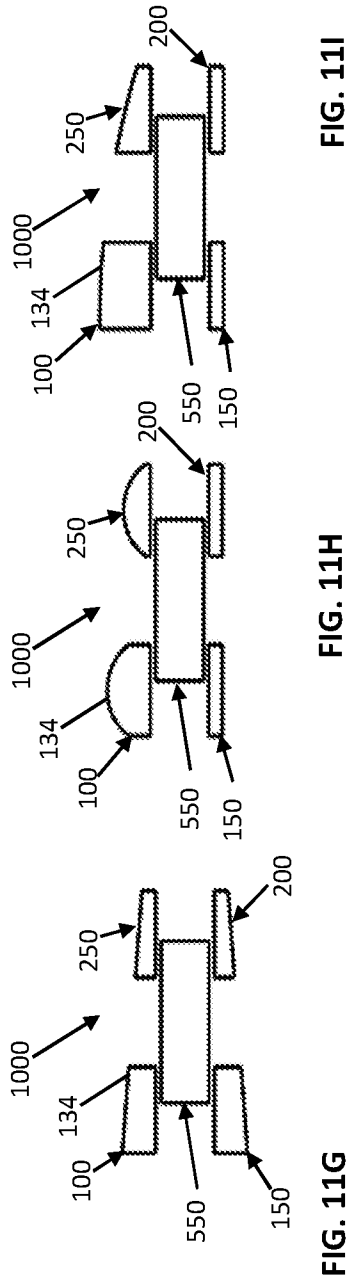
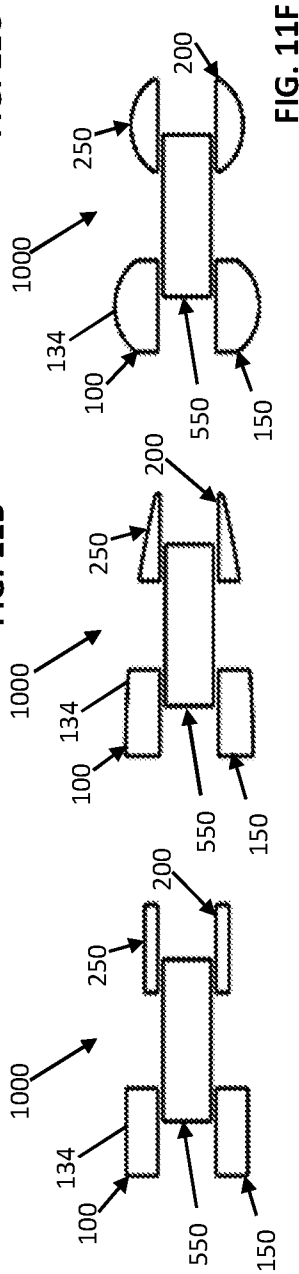
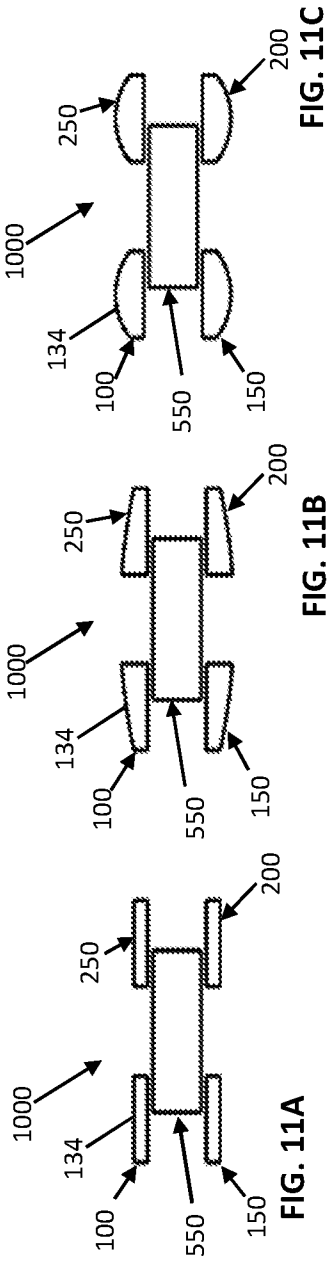
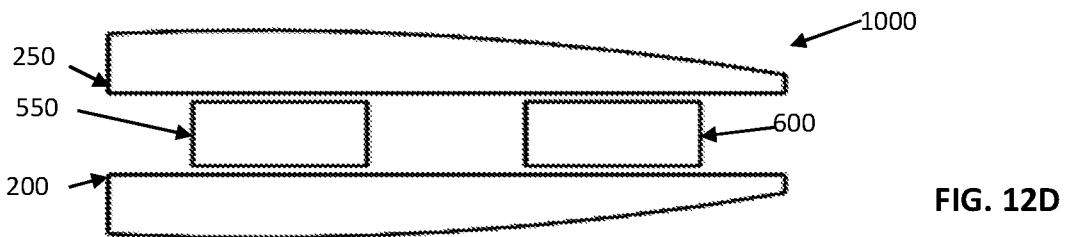
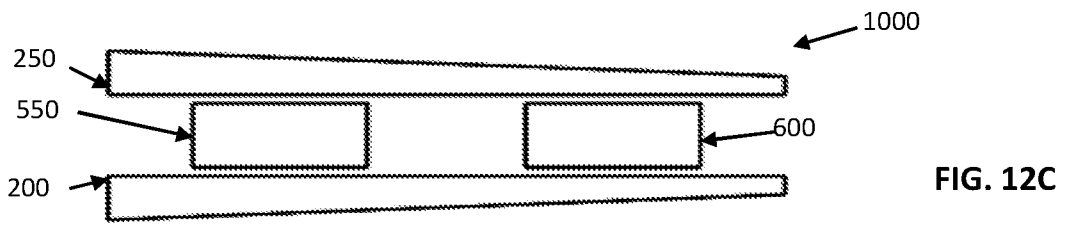
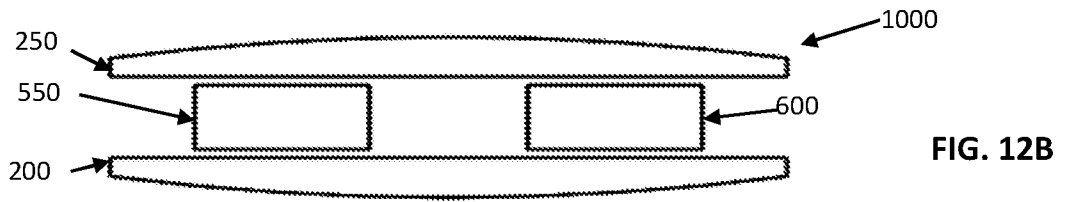
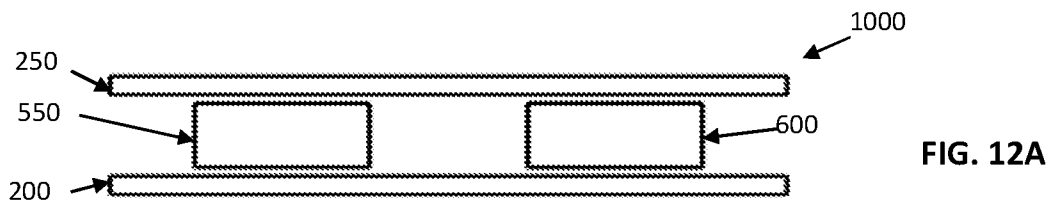

FIG. 10D3





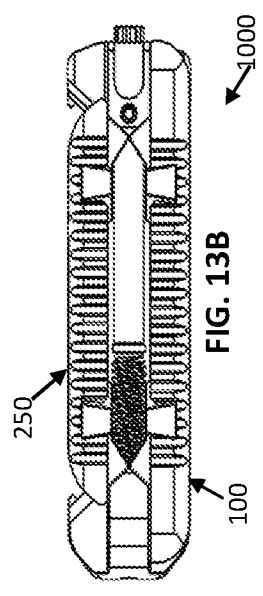

FIG. 13B

Two of the endplates have shorter Length than the other two

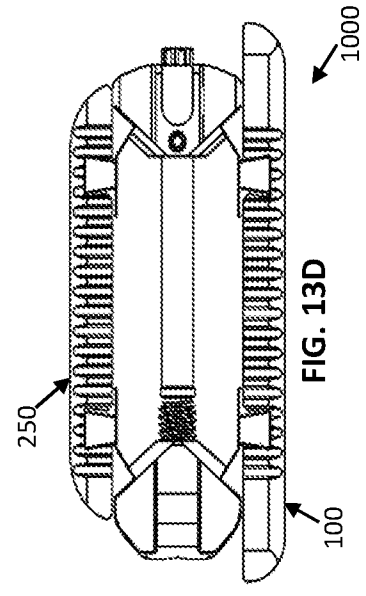

FIG. 13D

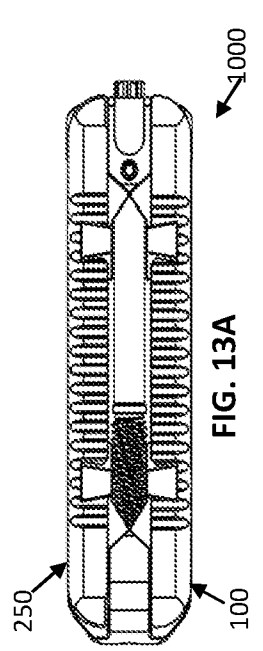

FIG. 13A

All endplates are the same length

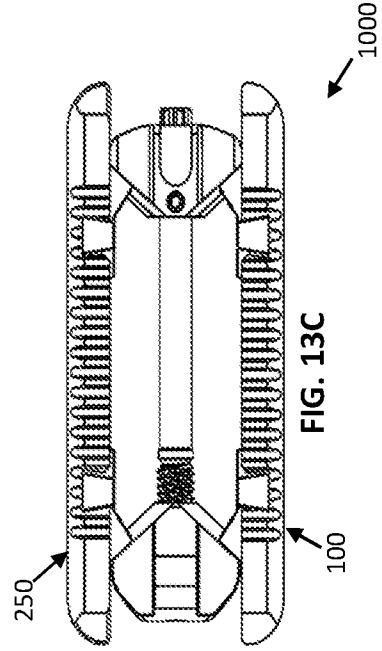

FIG. 13C

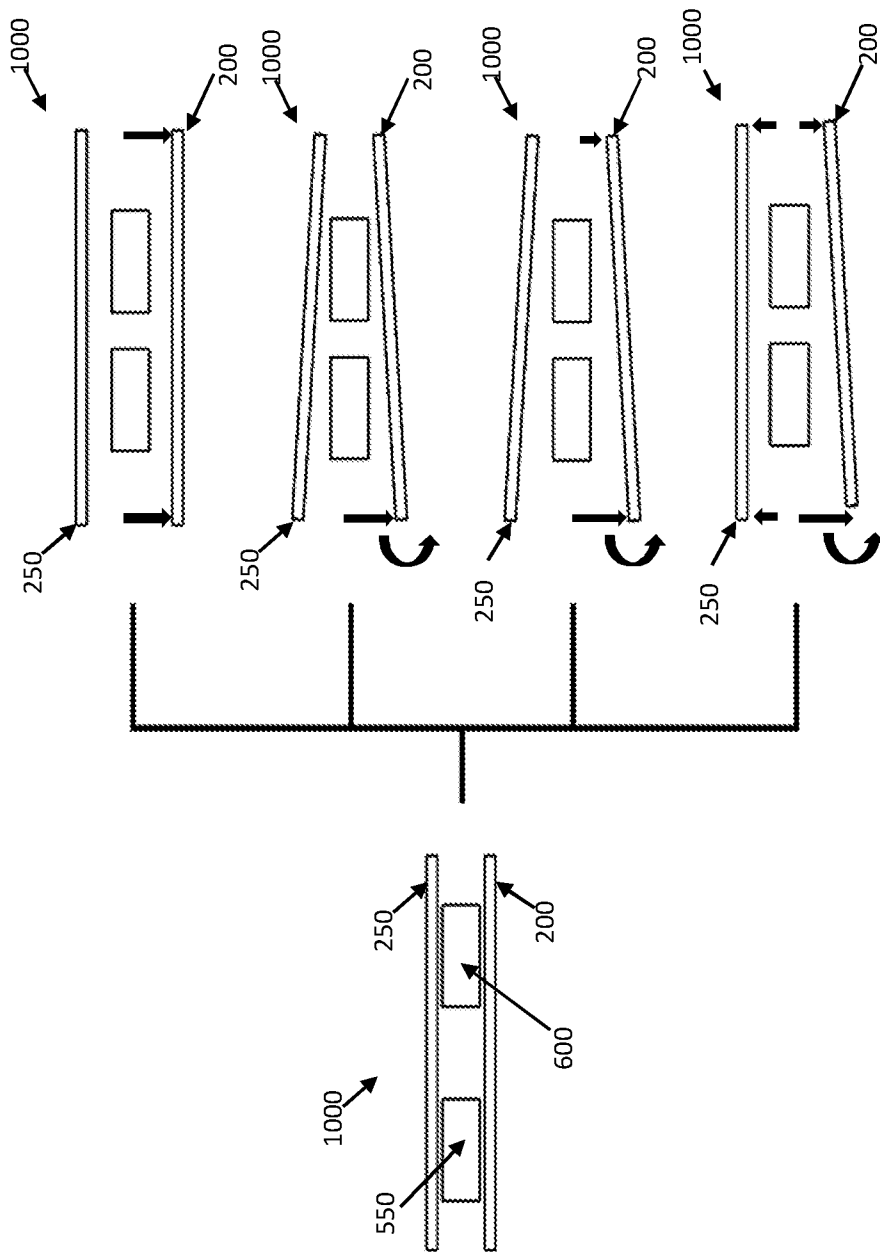

FIG. 14A

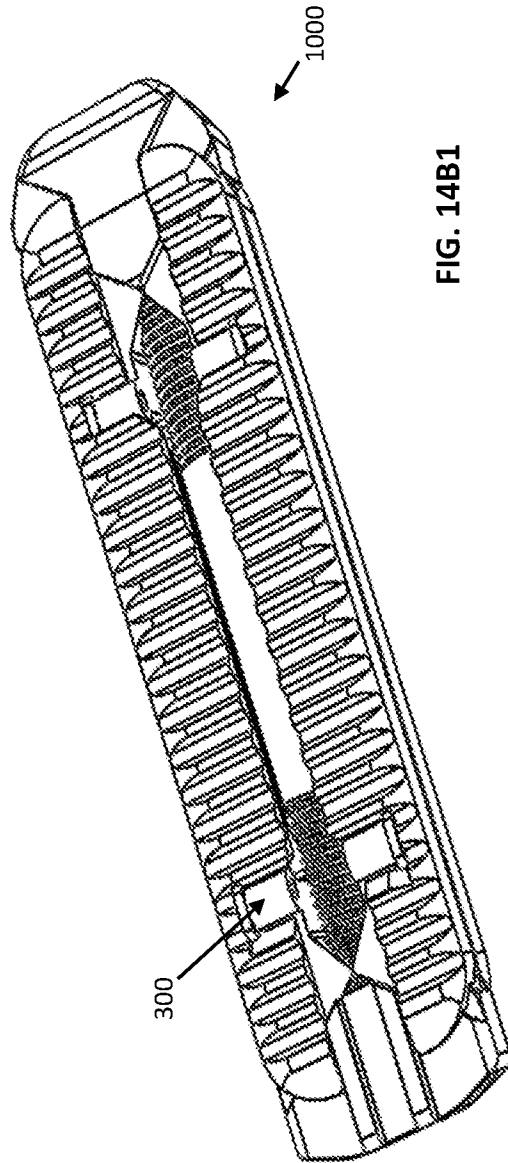

FIG. 14B1

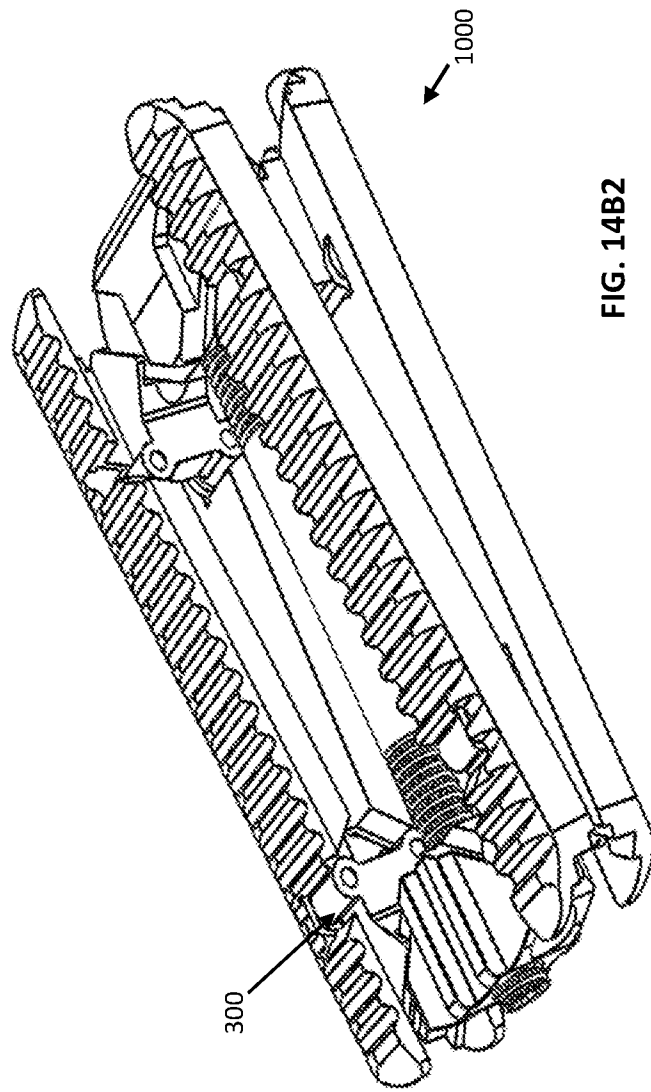

FIG. 14B2

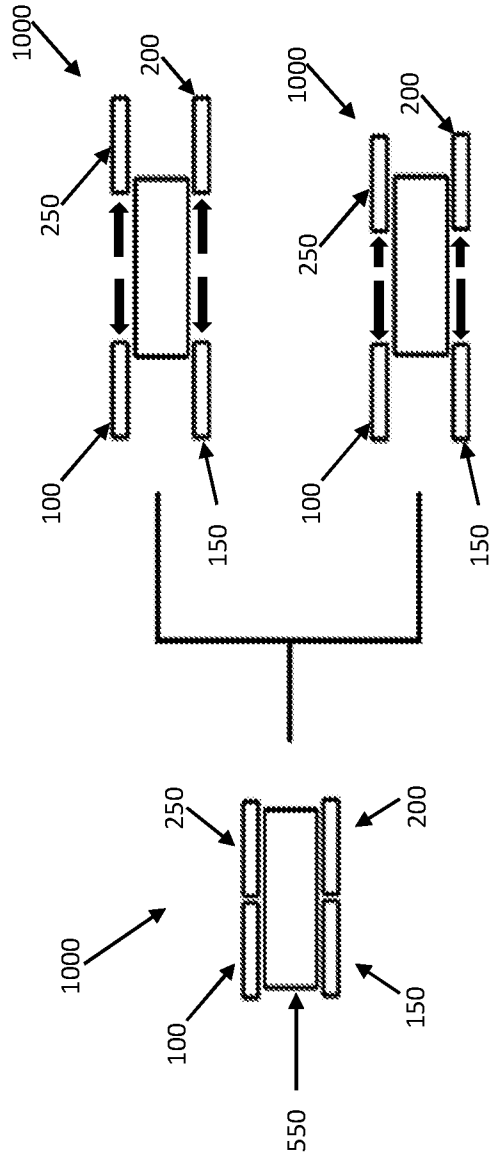

FIG. 15A

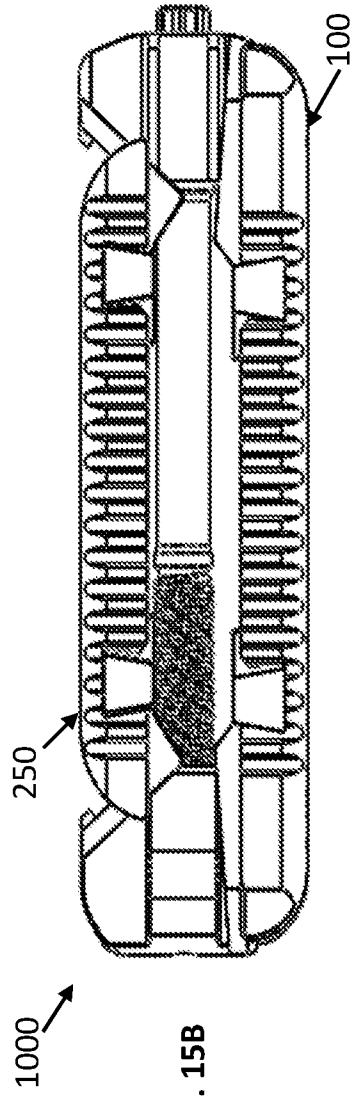

FIG. 15B

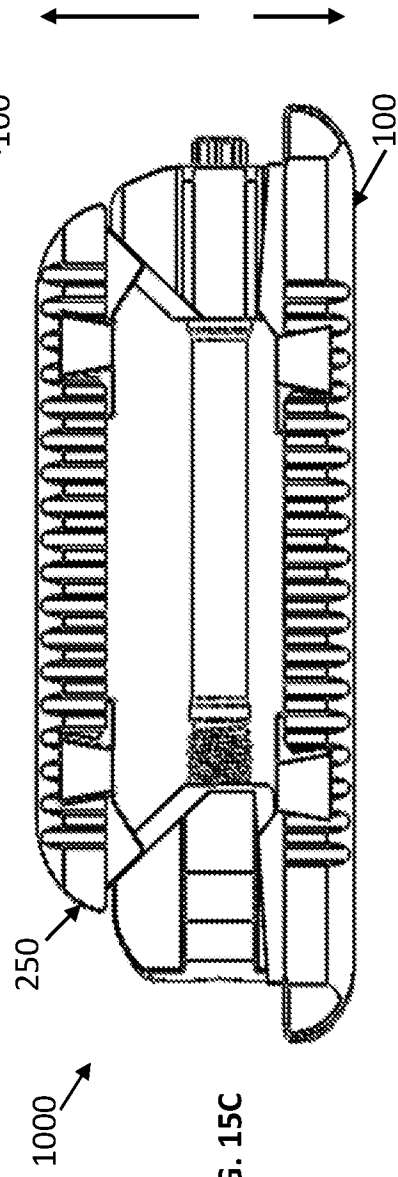

FIG. 15C

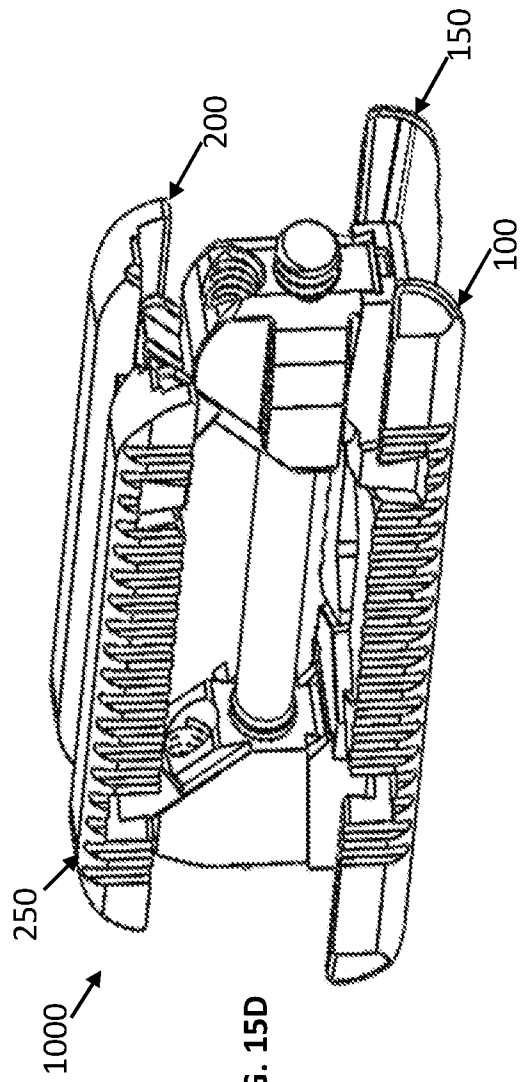

FIG. 15D

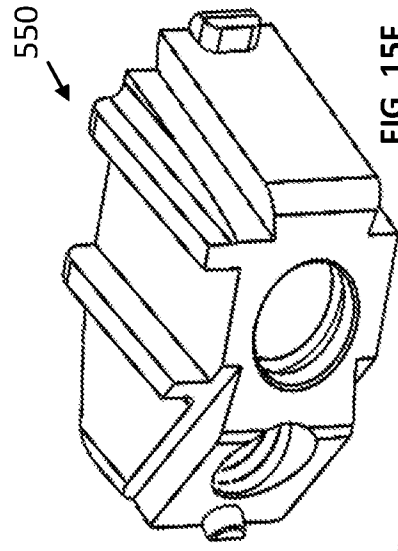

FIG. 15F

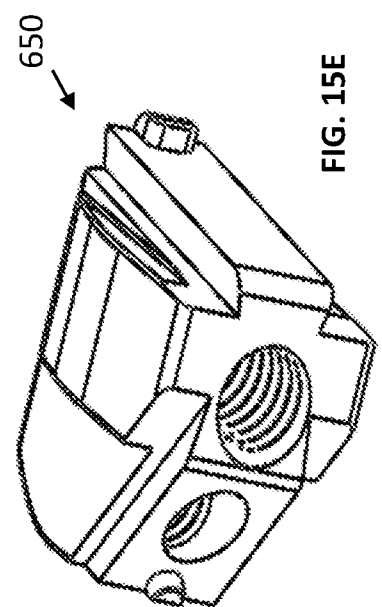

FIG. 15E

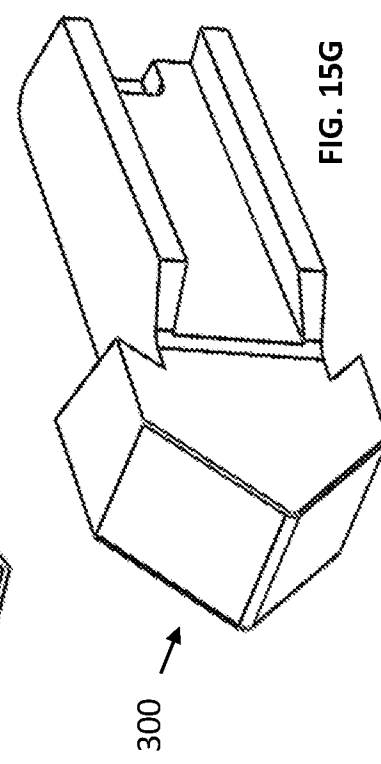
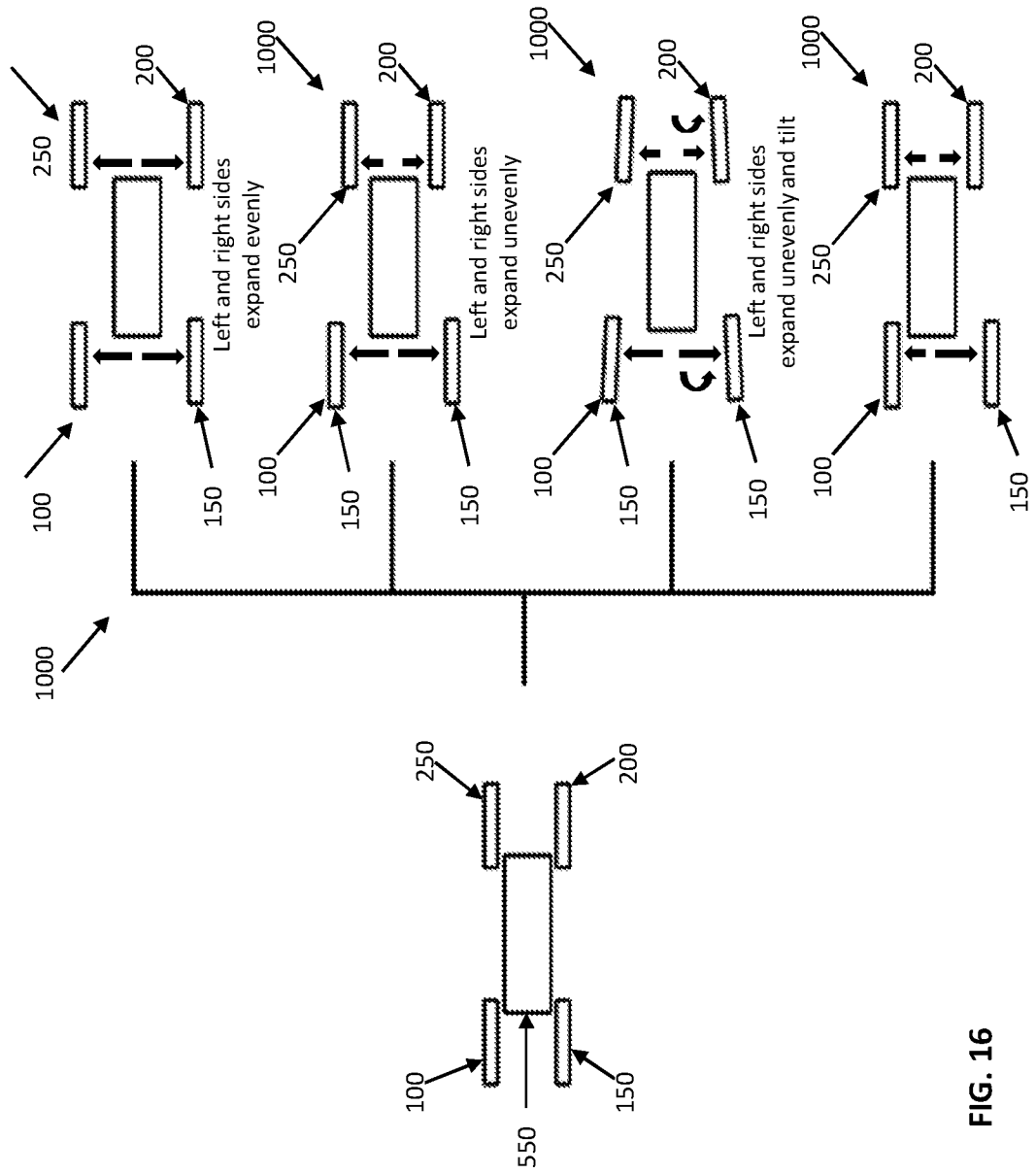
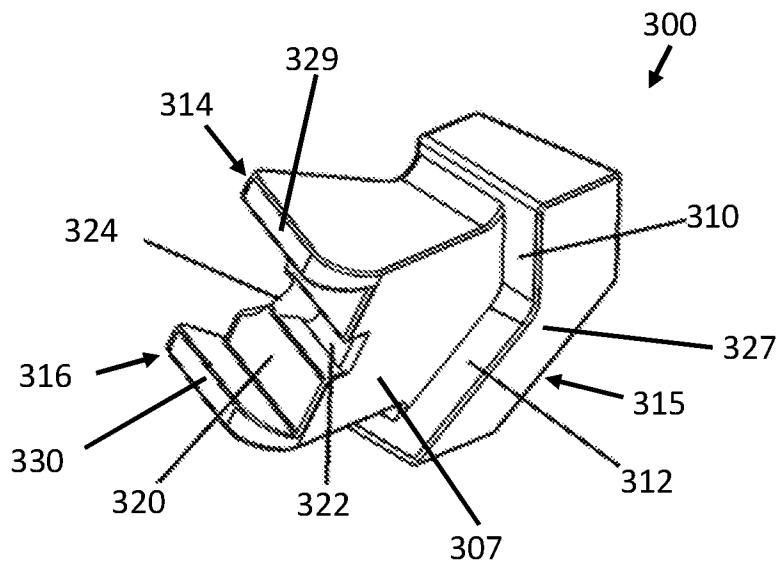
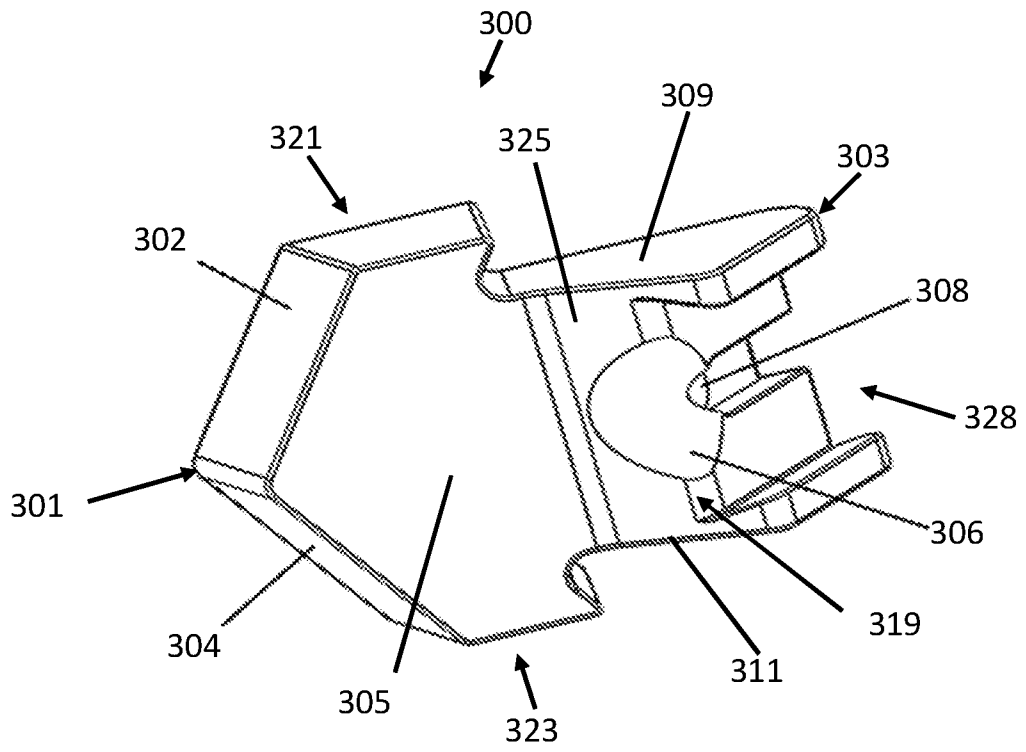

FIG. 15G





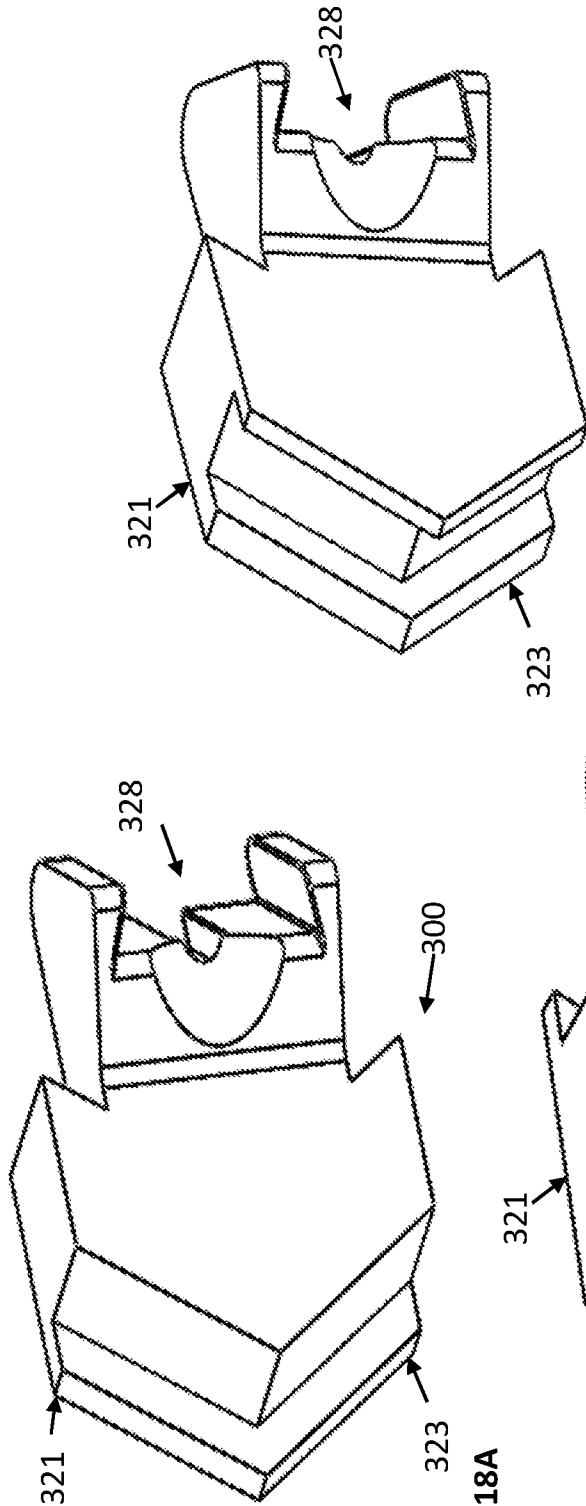

FIG. 18A

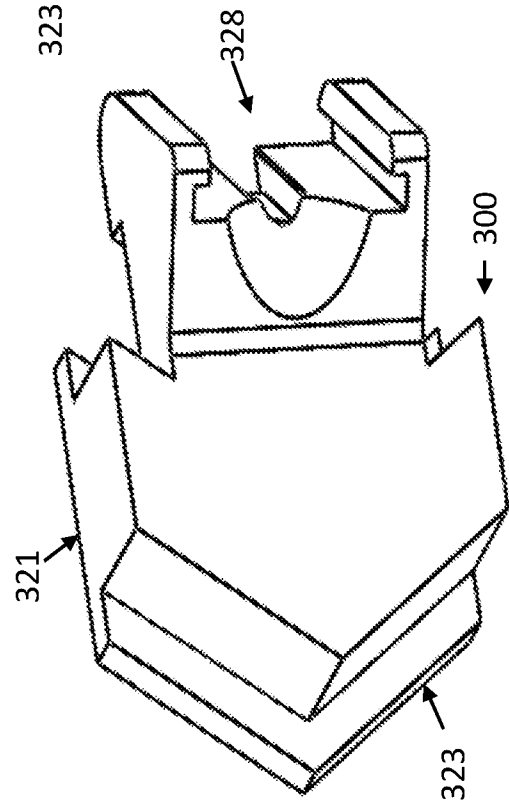

FIG. 18B

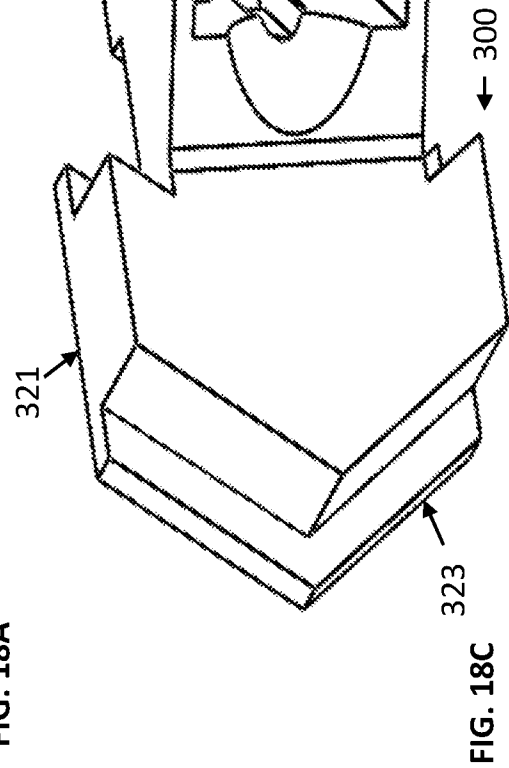
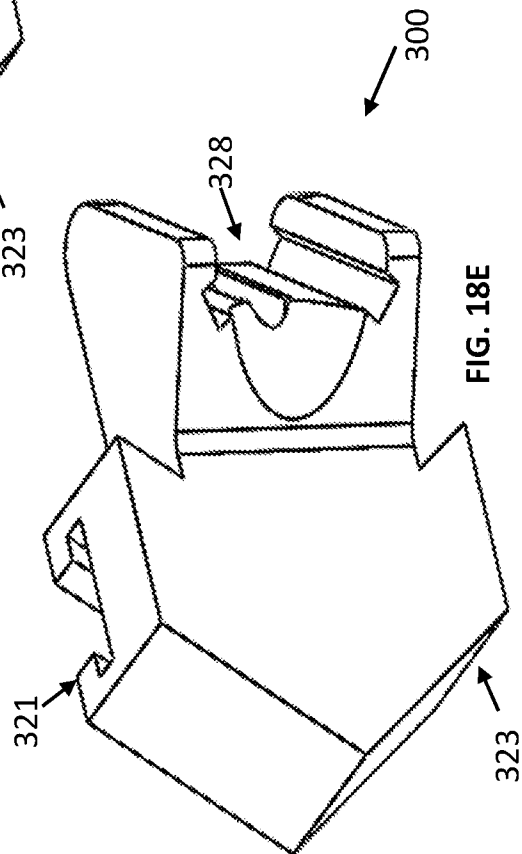
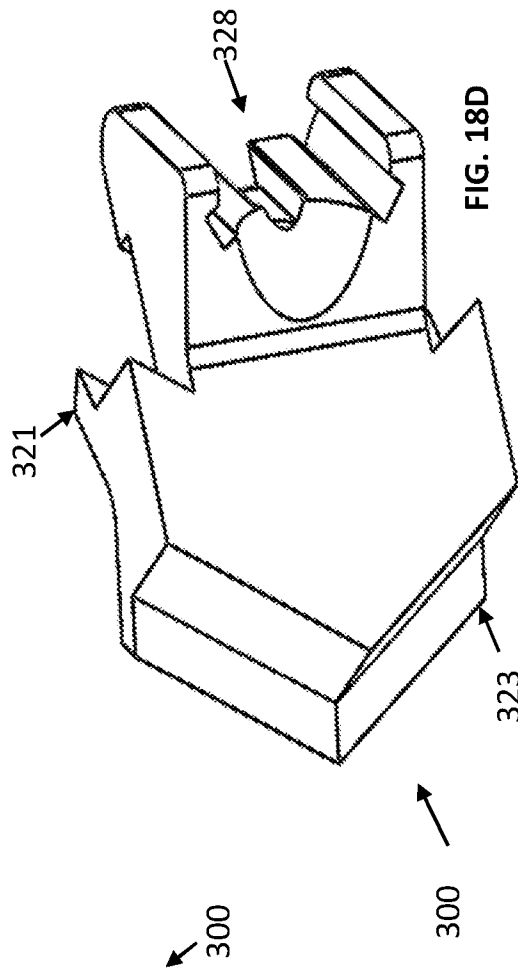
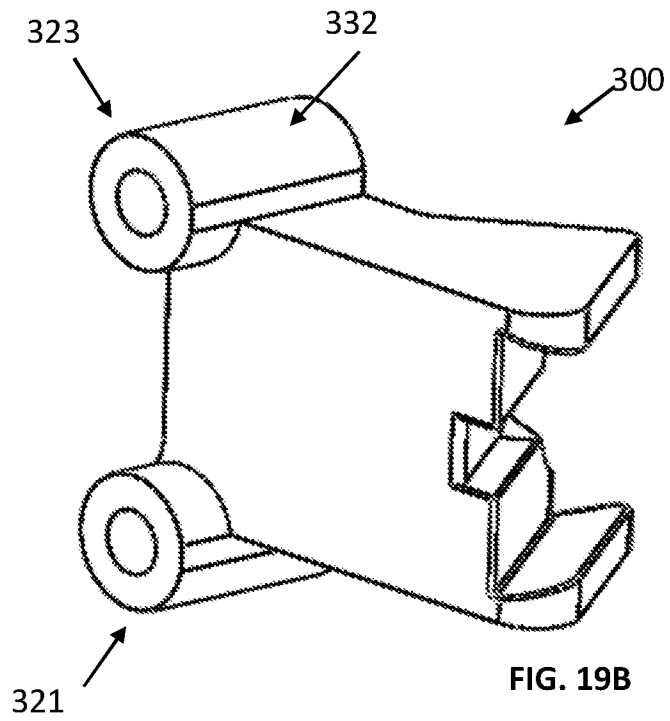
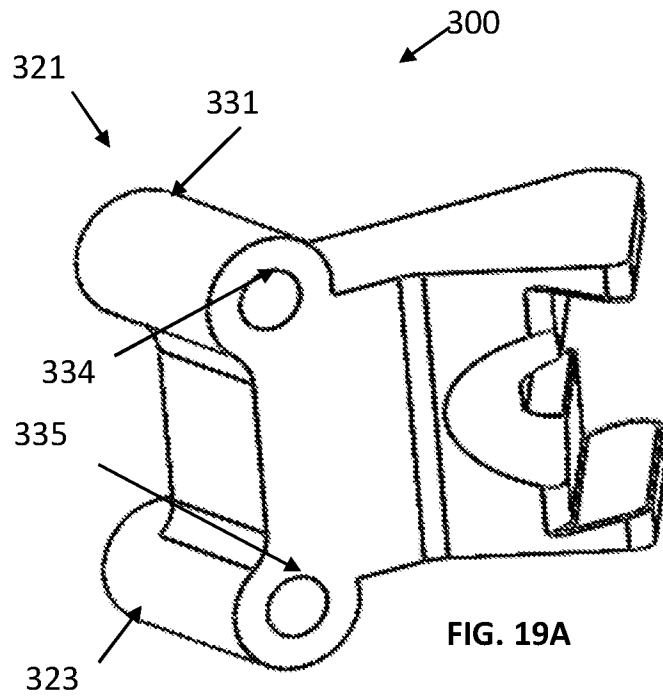
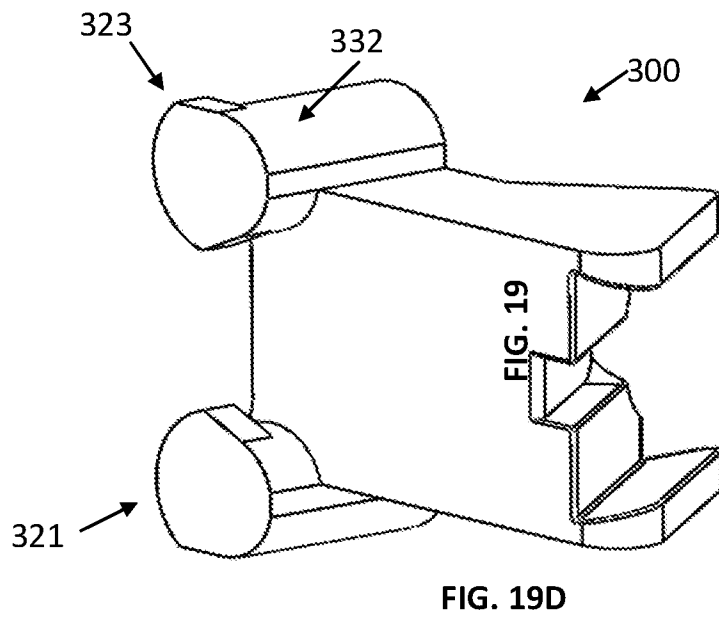
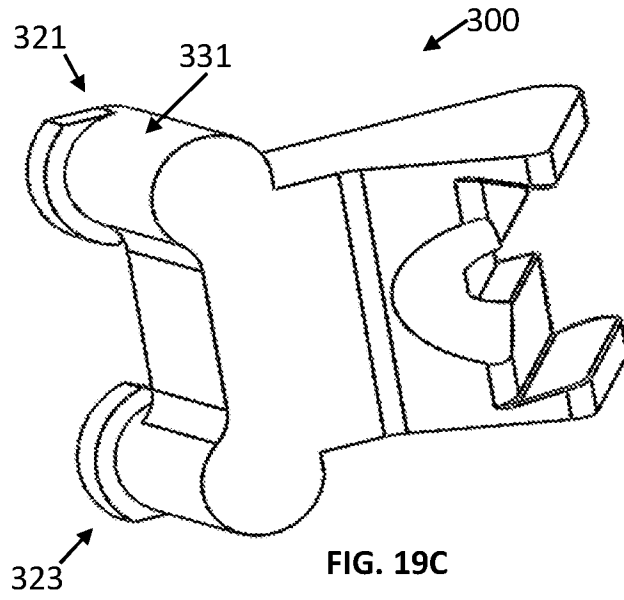
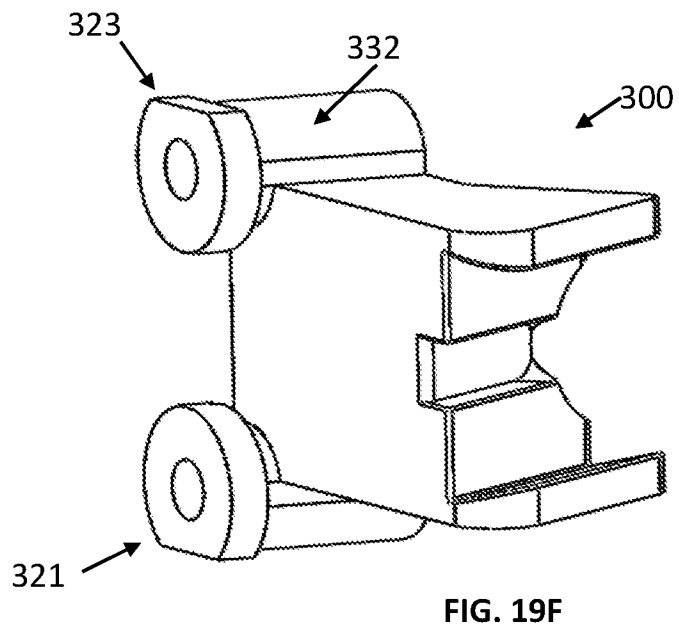
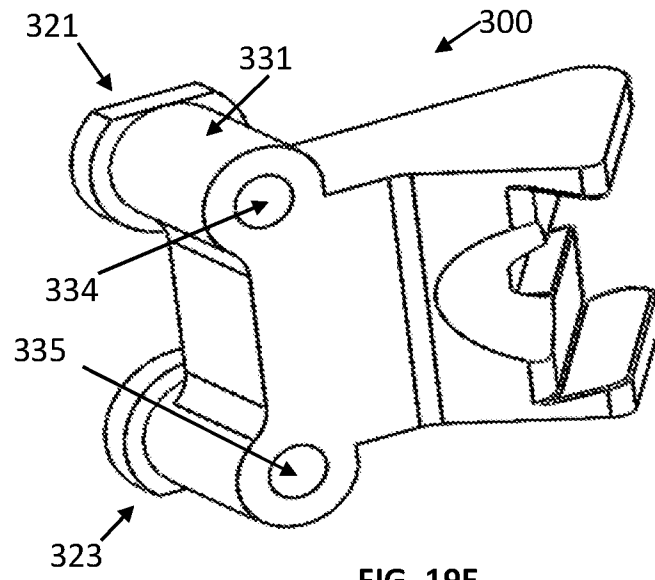

FIG. 18C









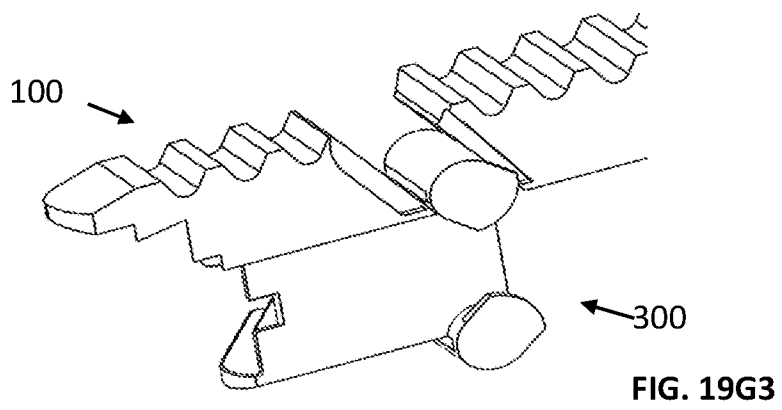
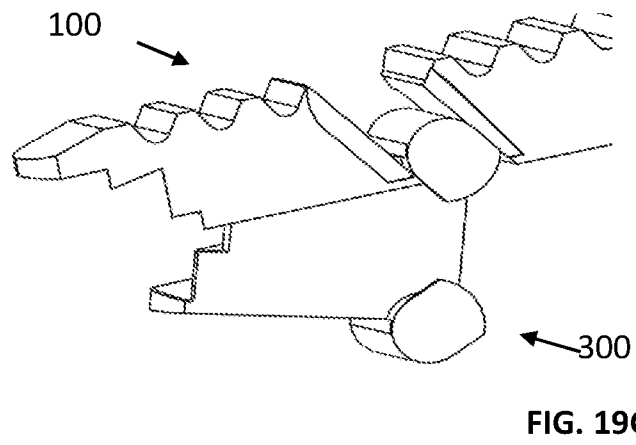
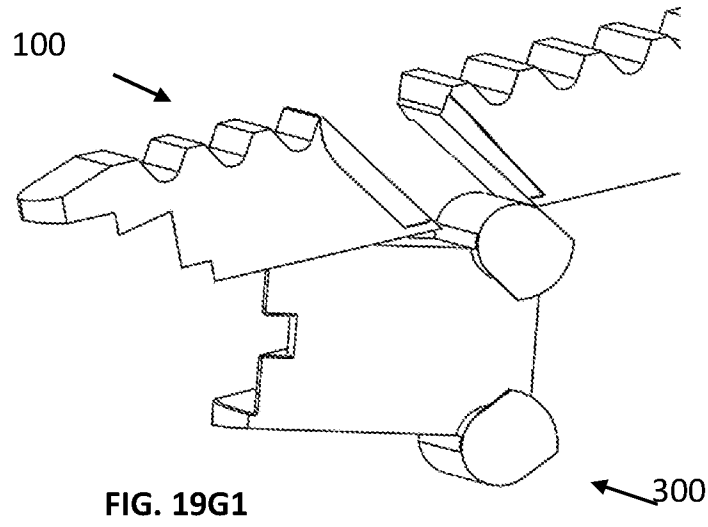

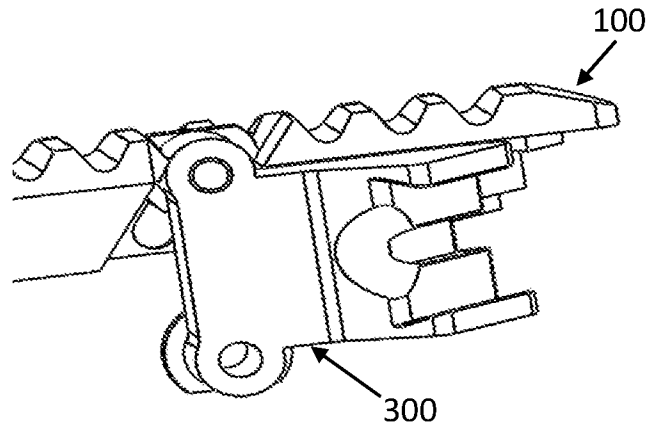

FIG. 19H1

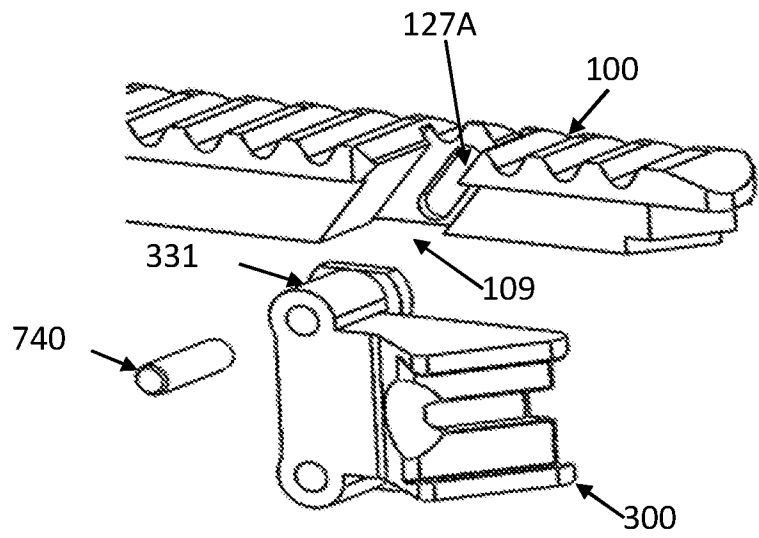
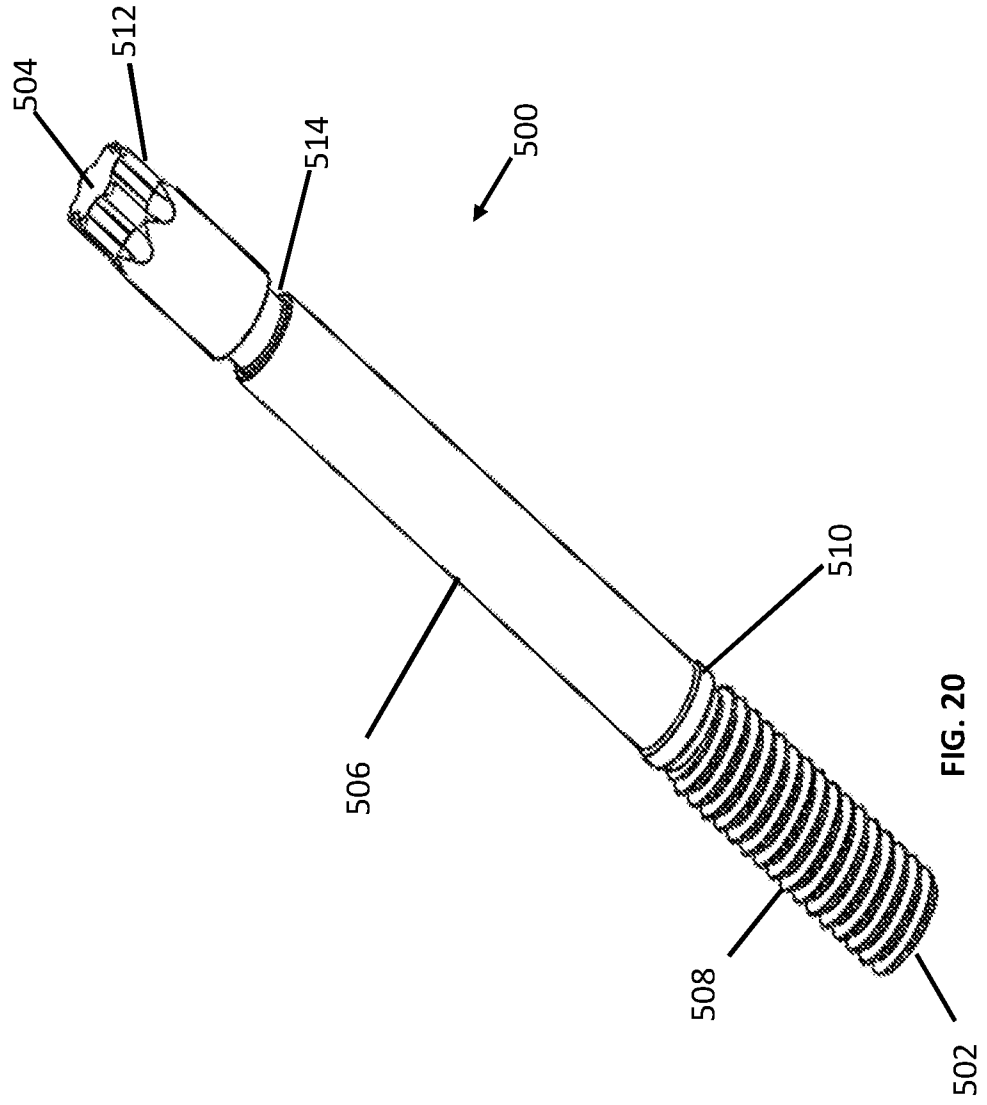
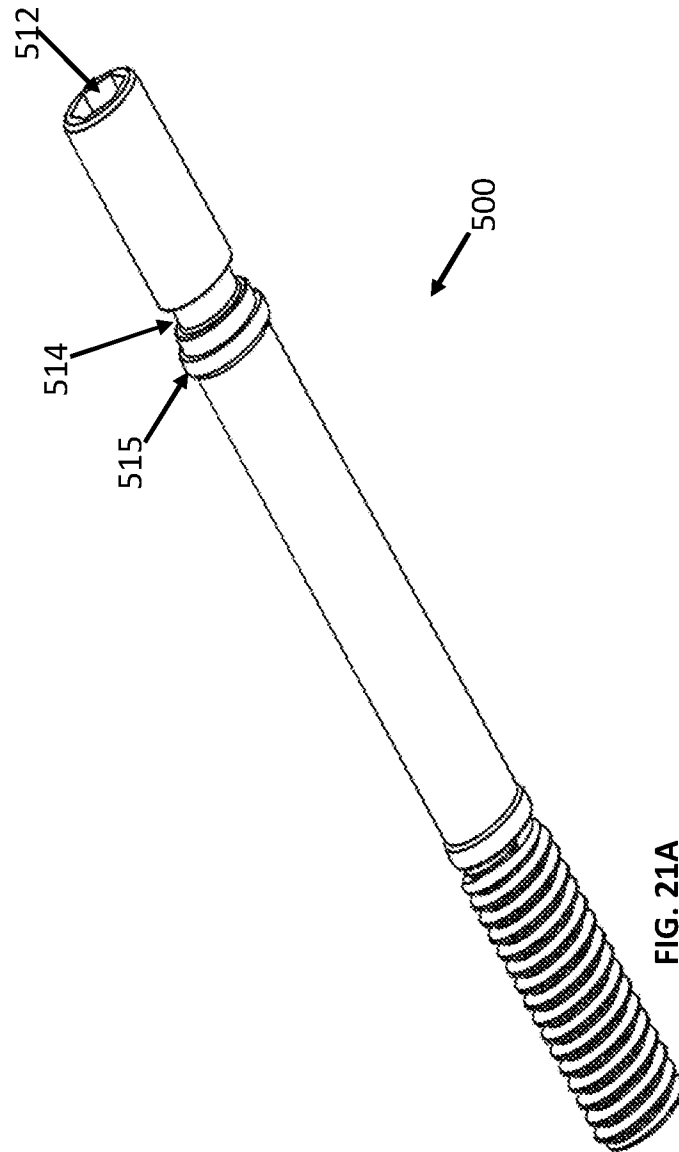

FIG. 19H2





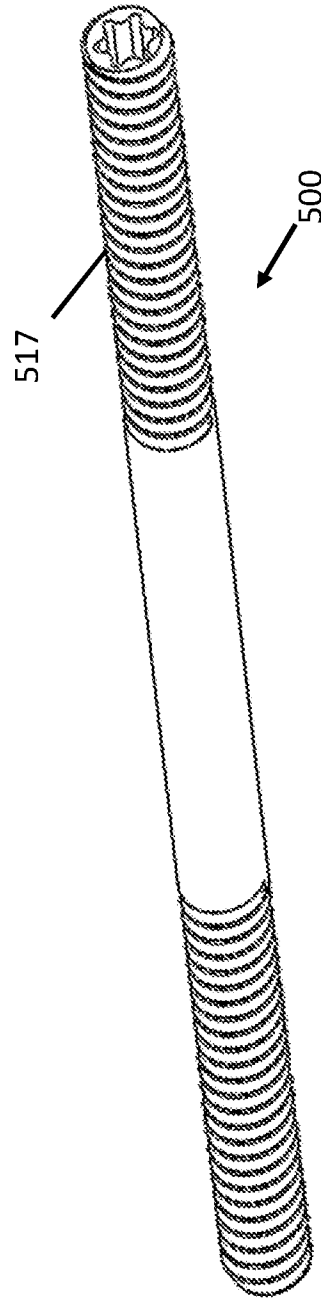
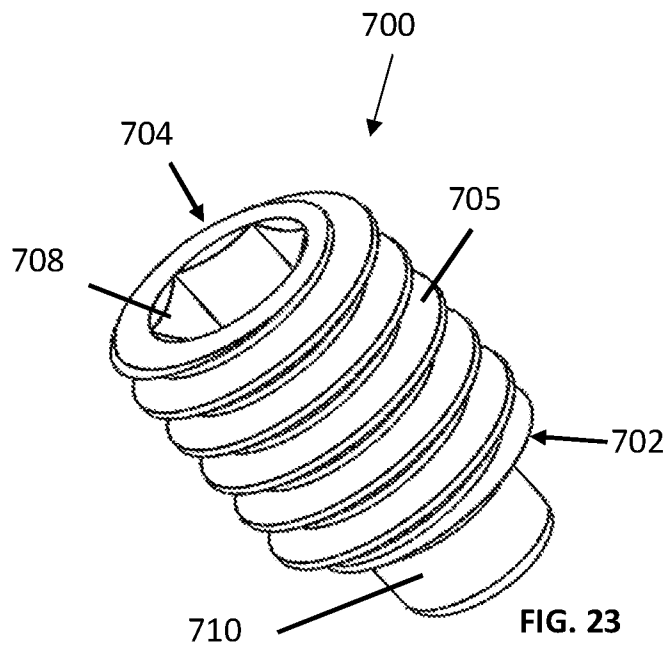
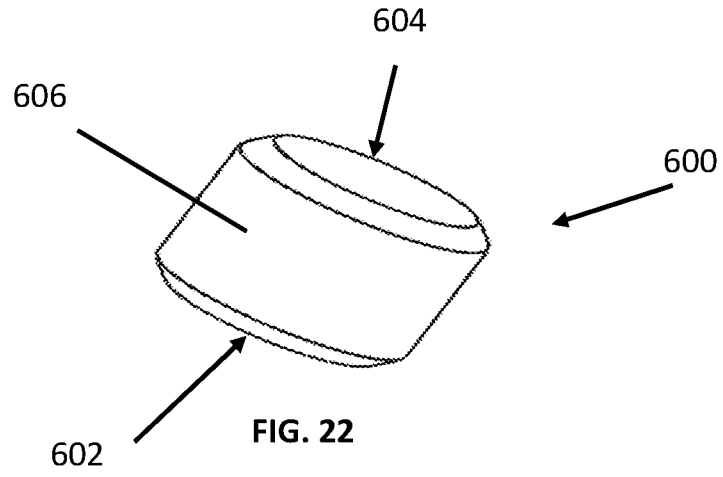
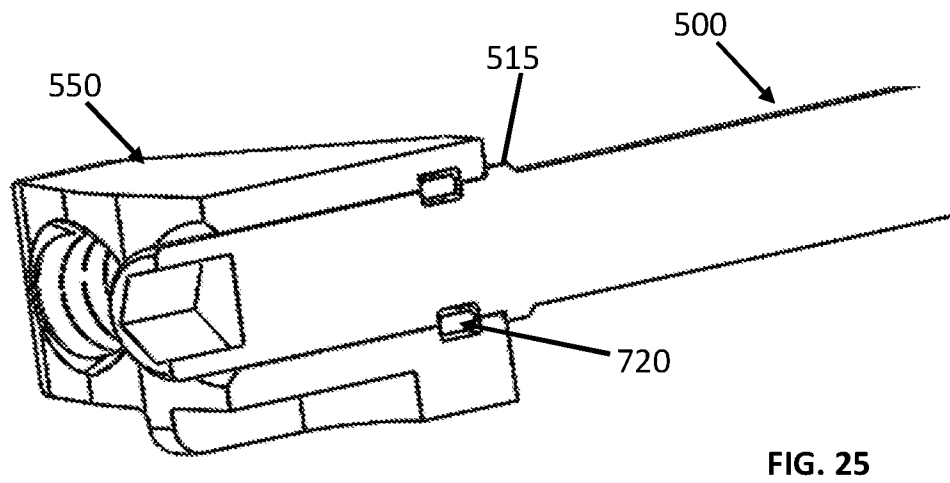
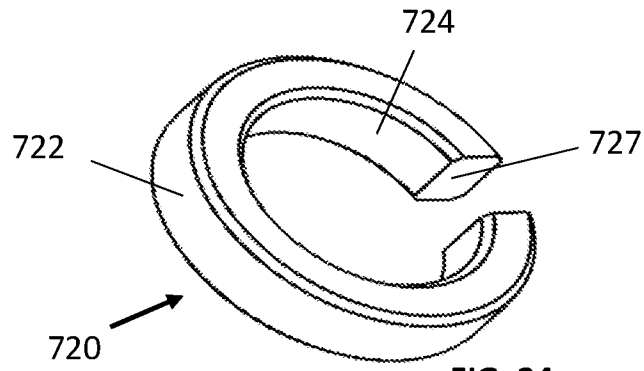

FIG. 21B





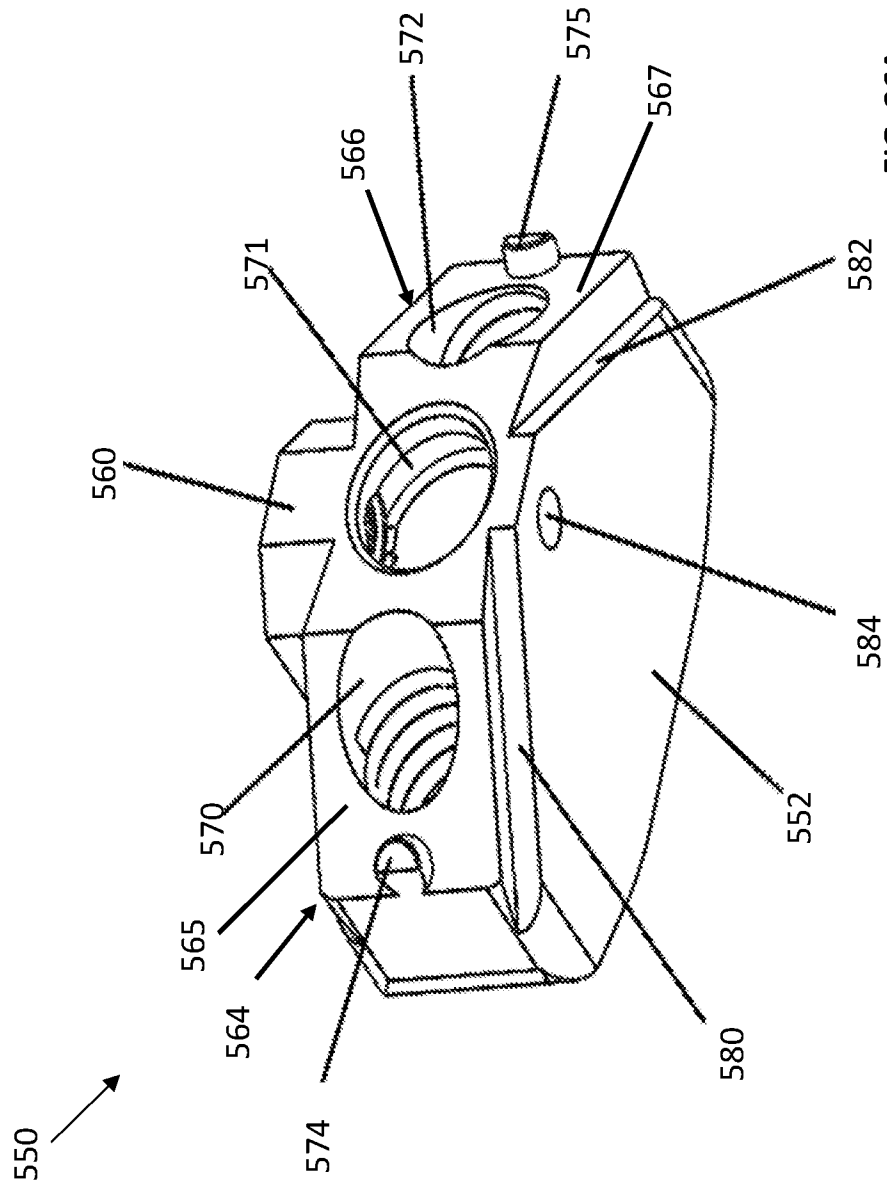

FIG. 26A

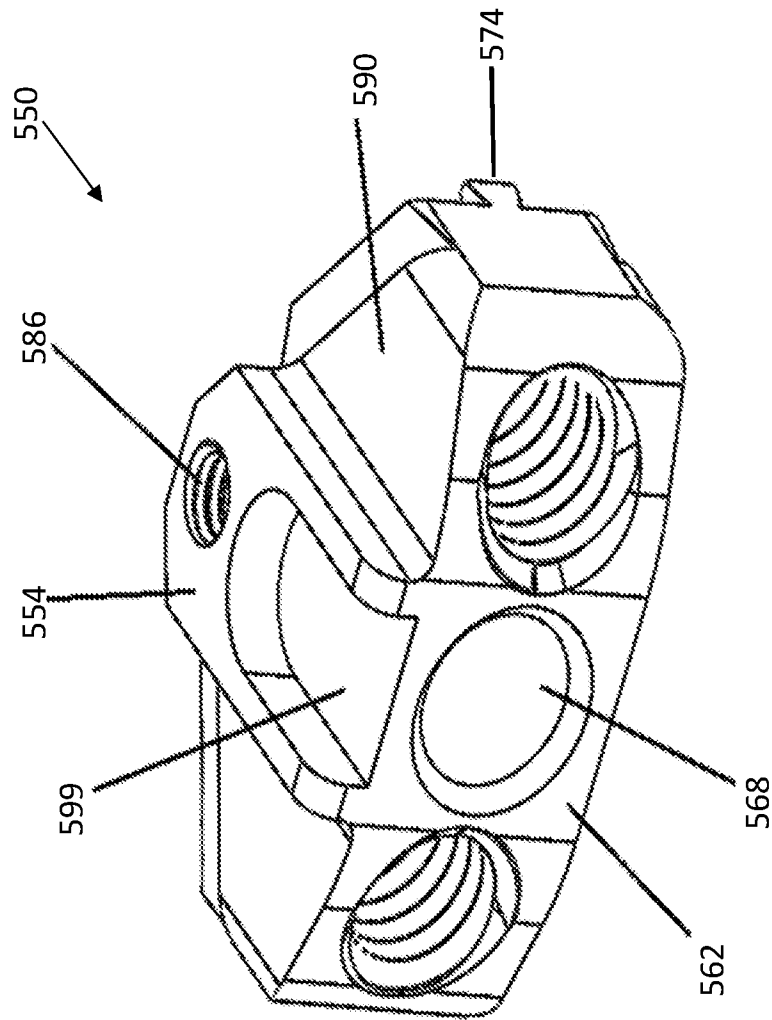
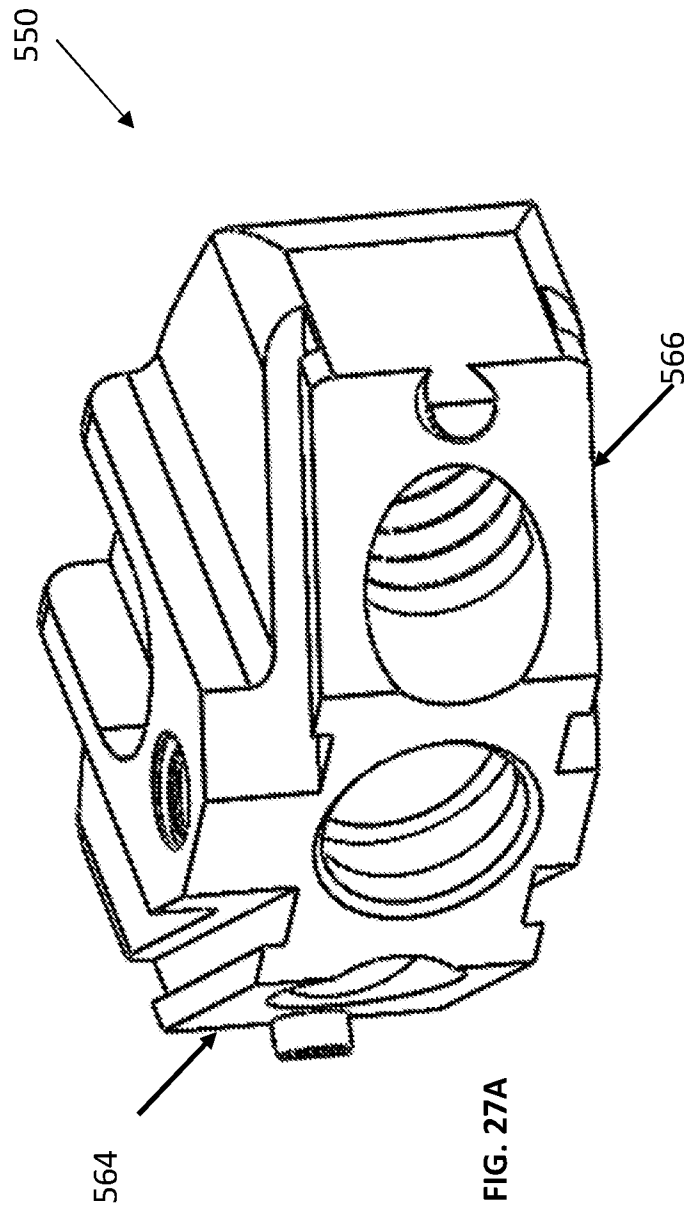
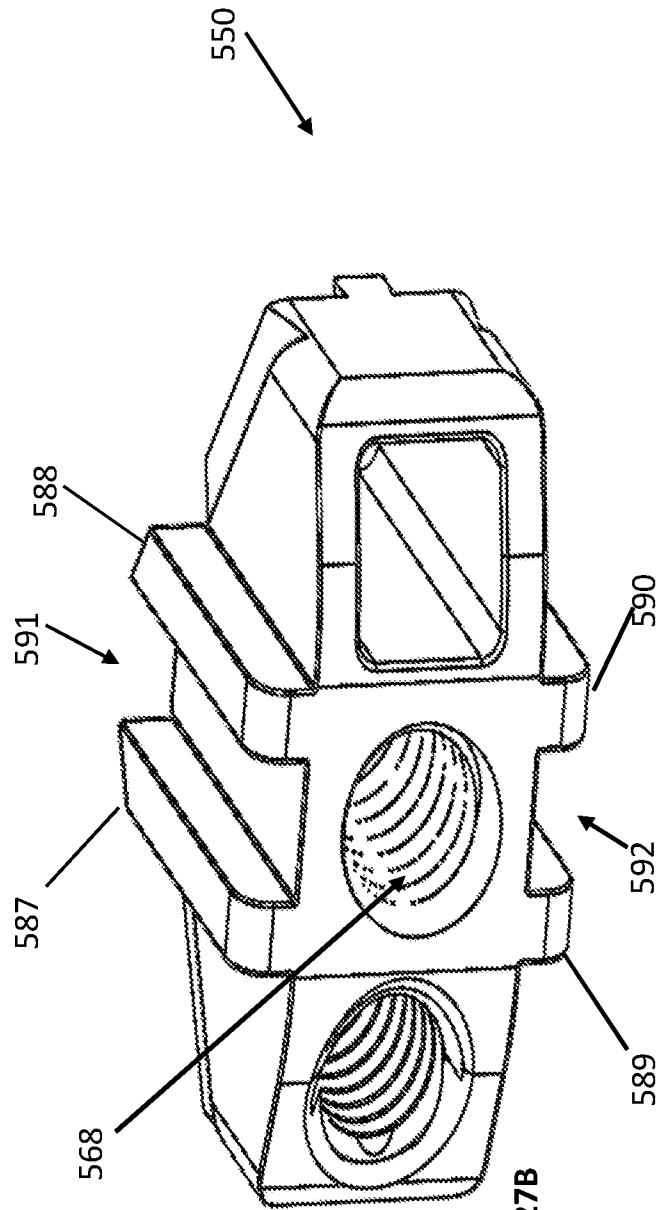
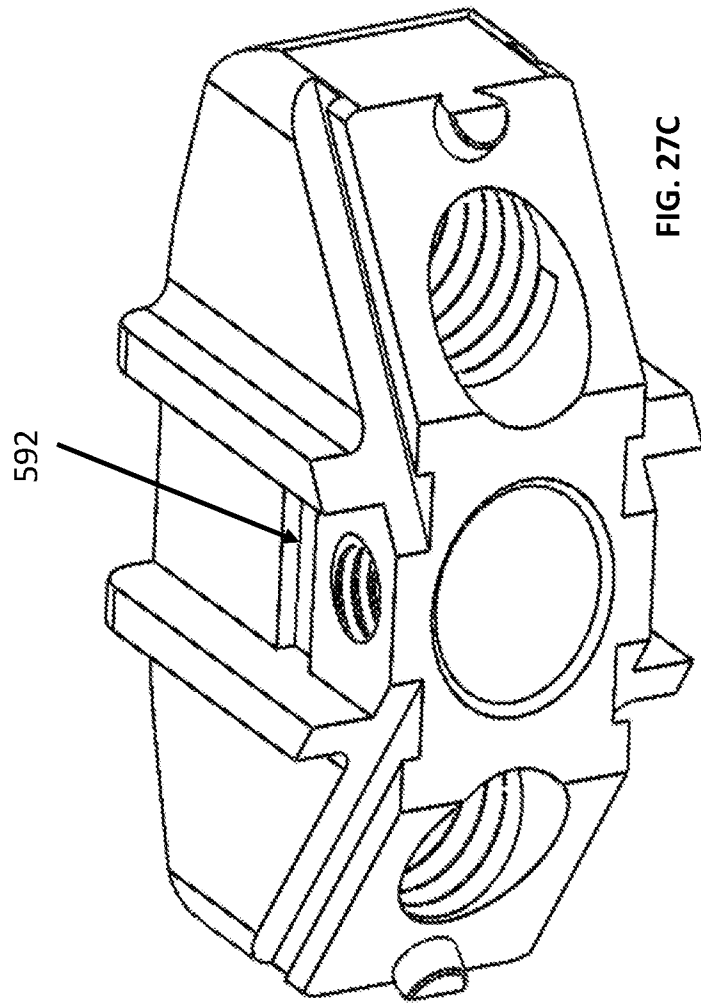

FIG. 26B







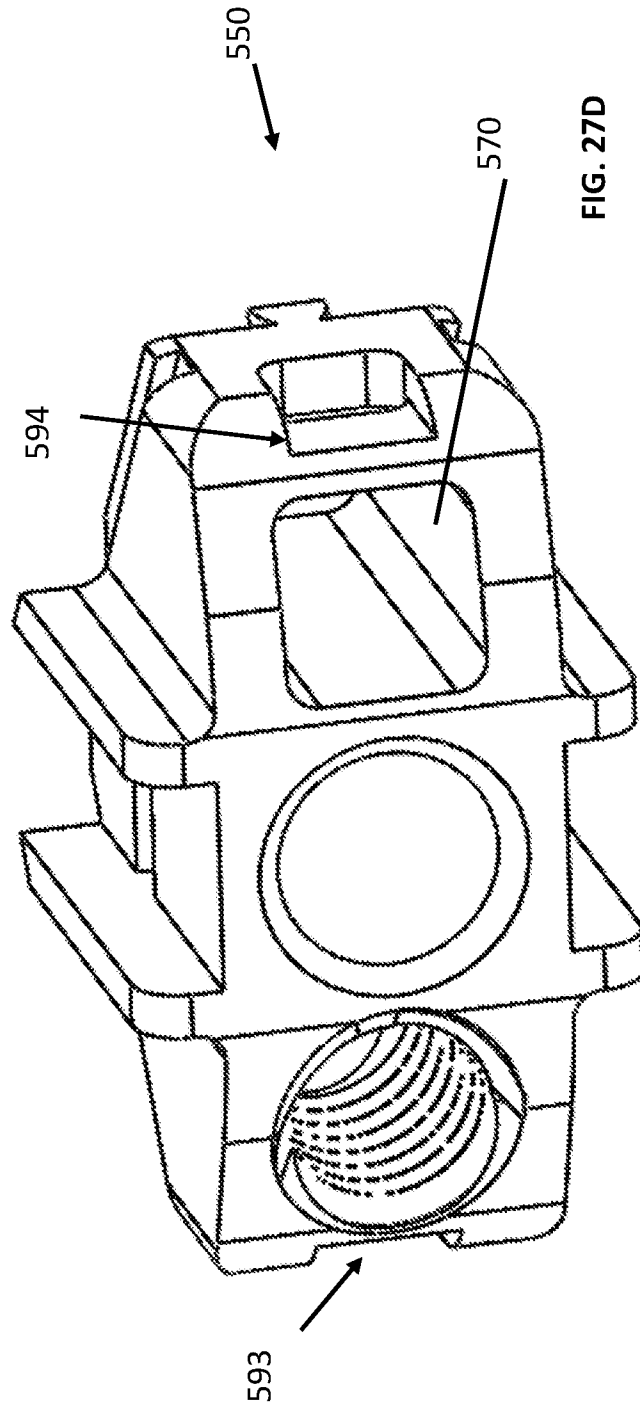

FIG. 27D

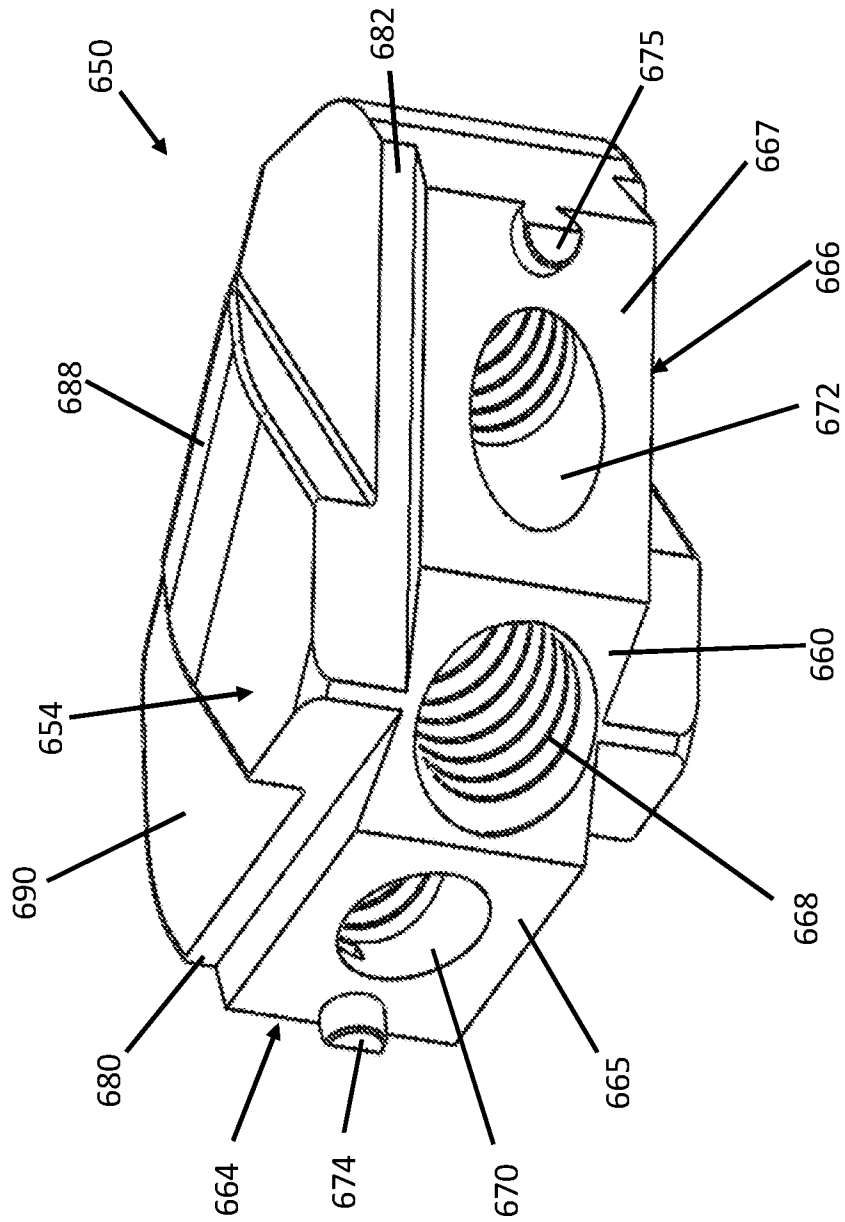

FIG. 28A

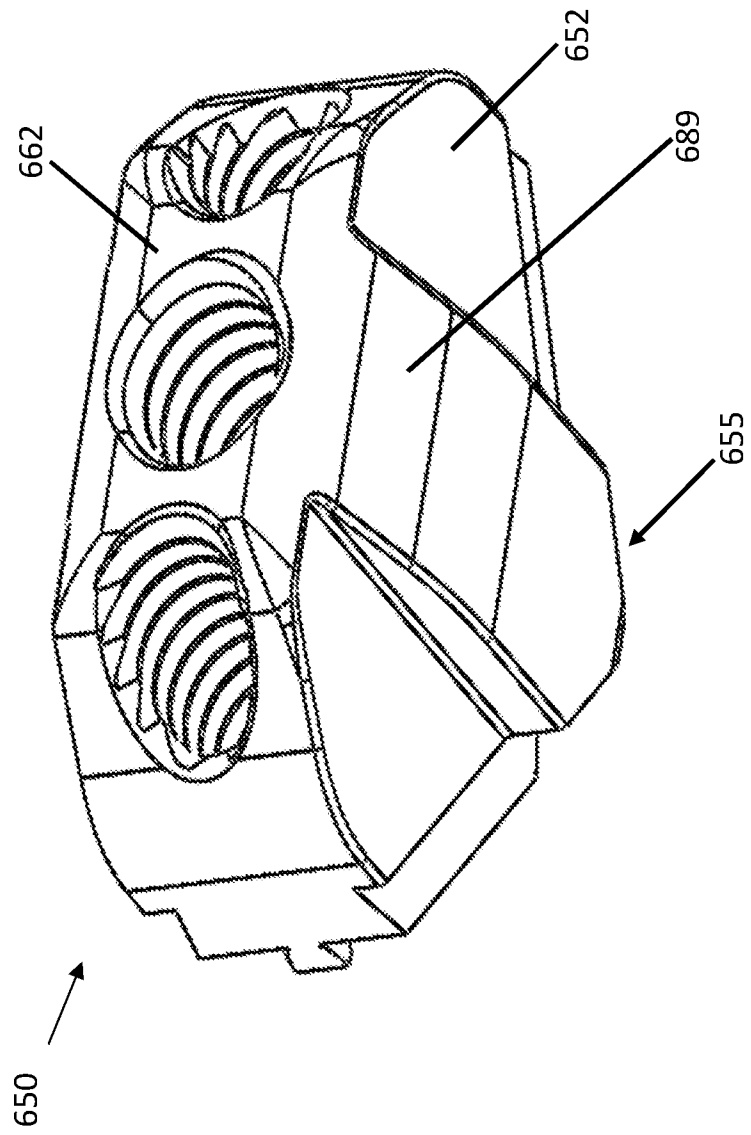

FIG. 28B

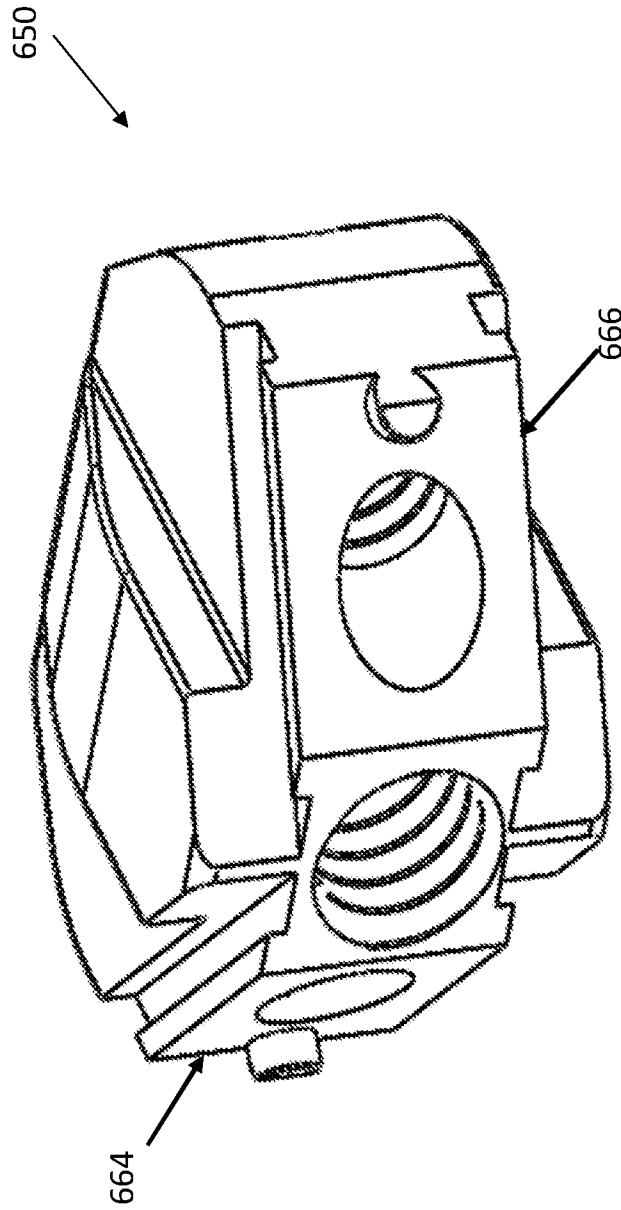

FIG. 29A

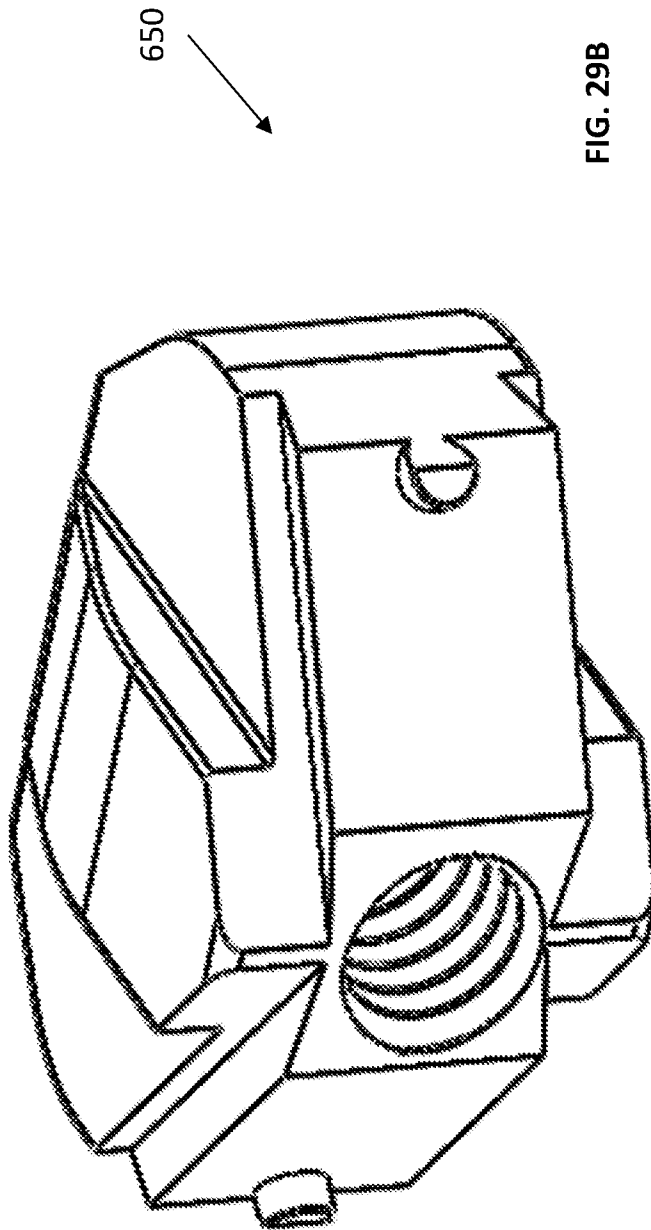

FIG. 29B

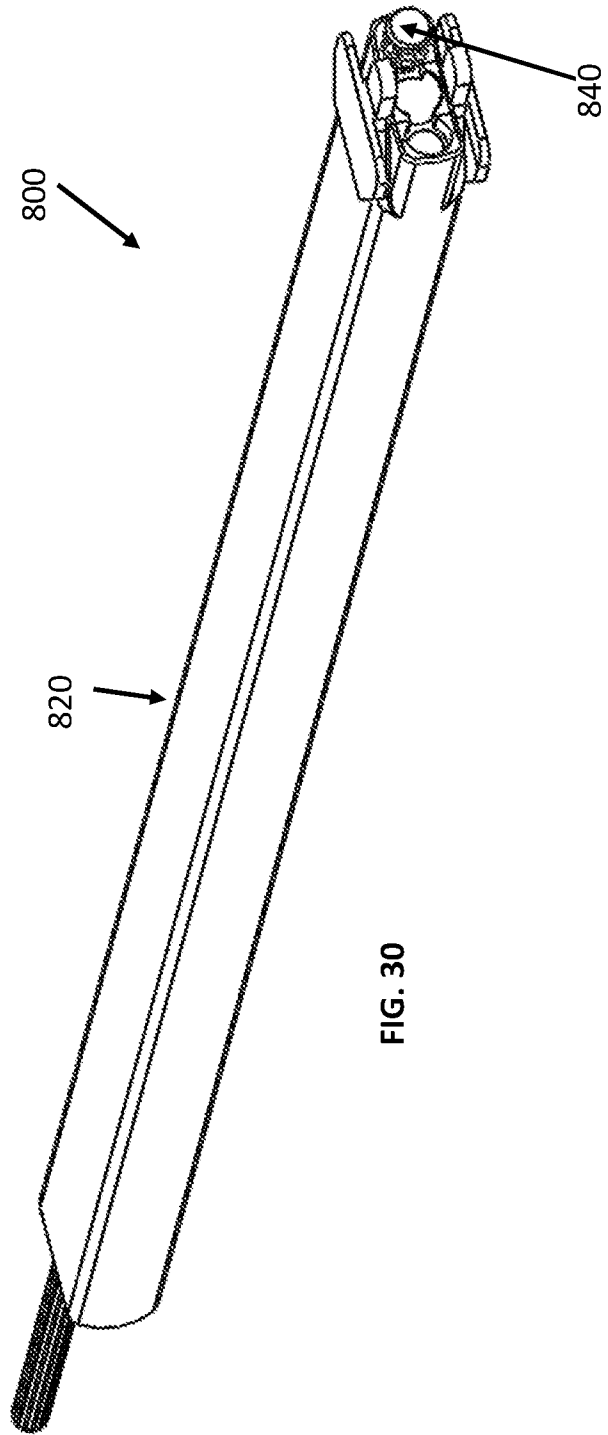
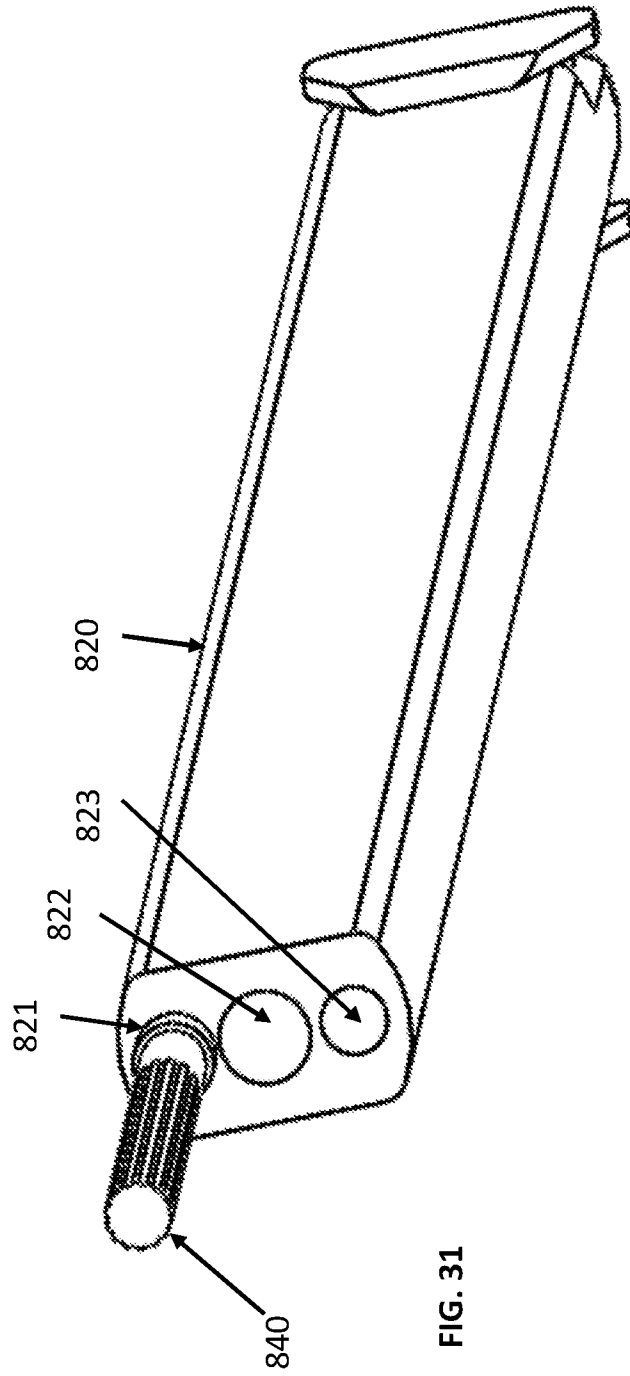

FIG. 30



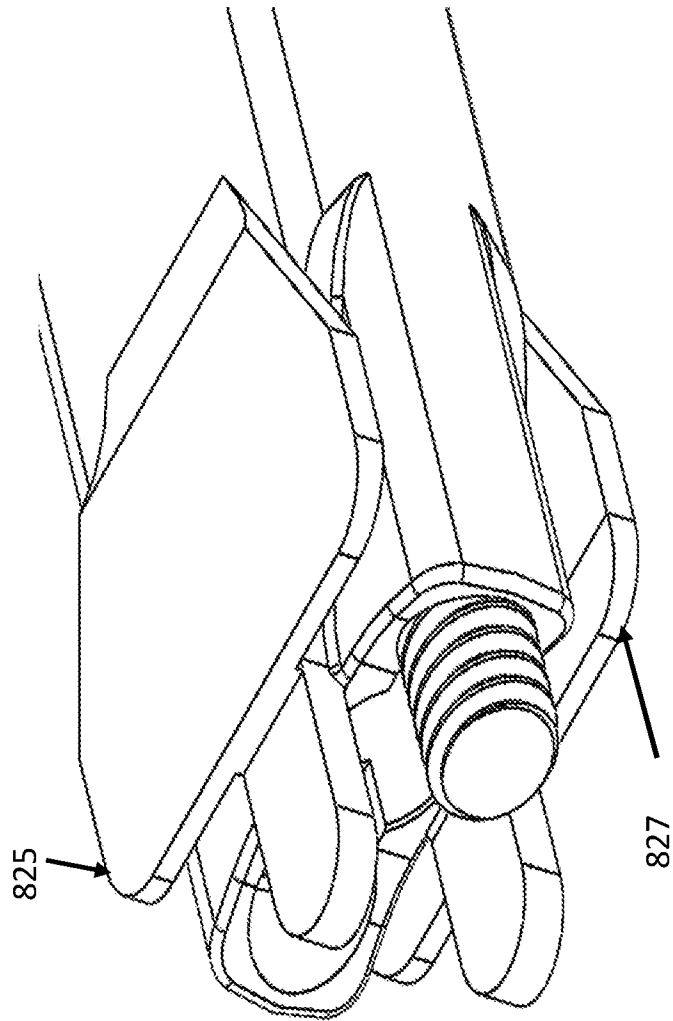
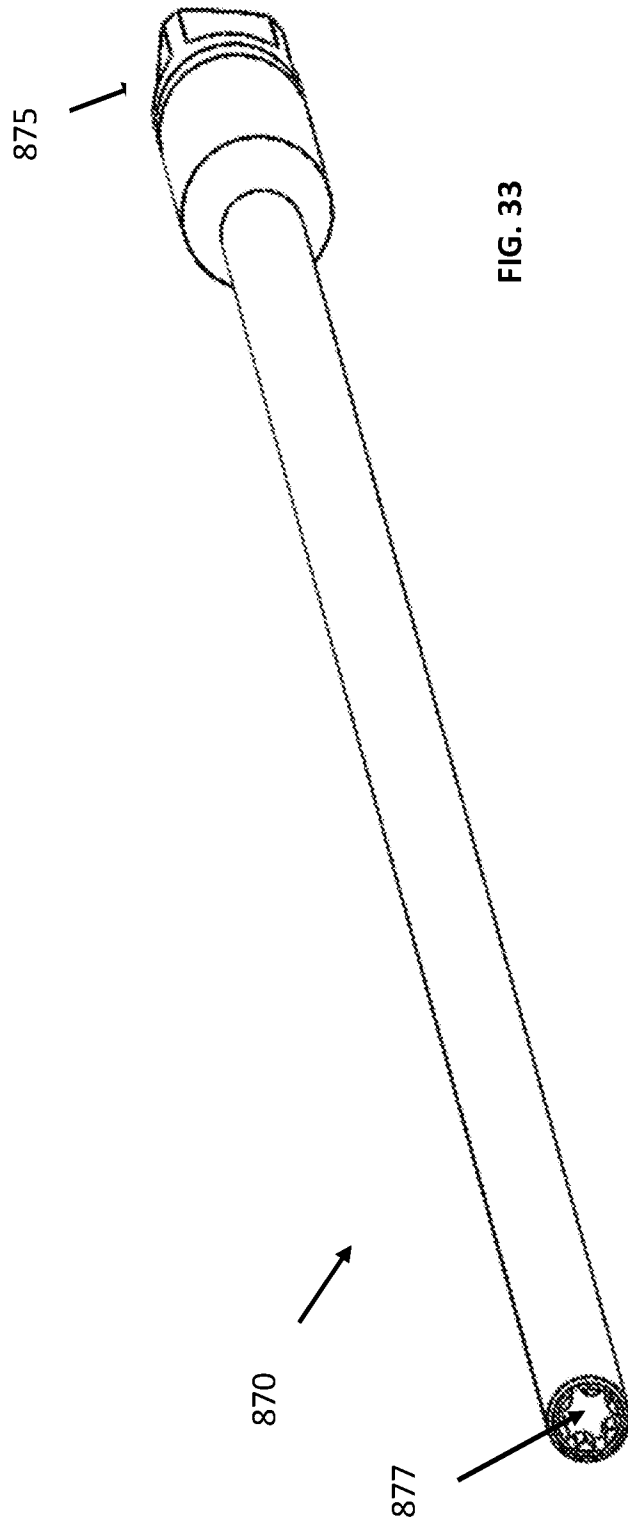
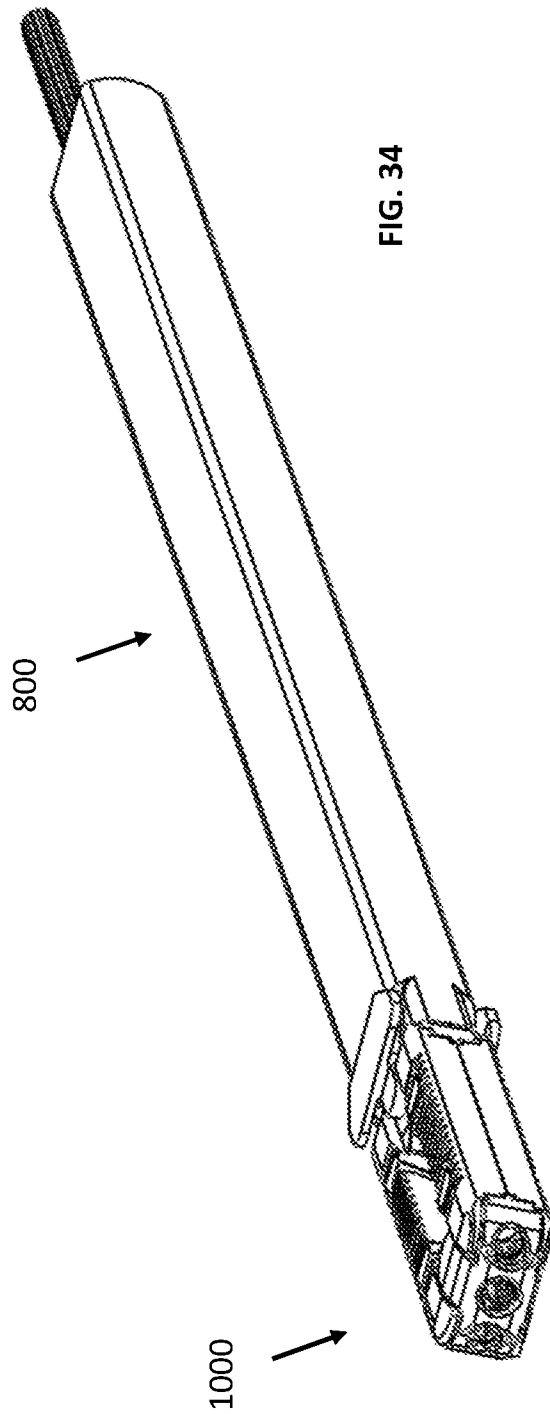

FIG. 32





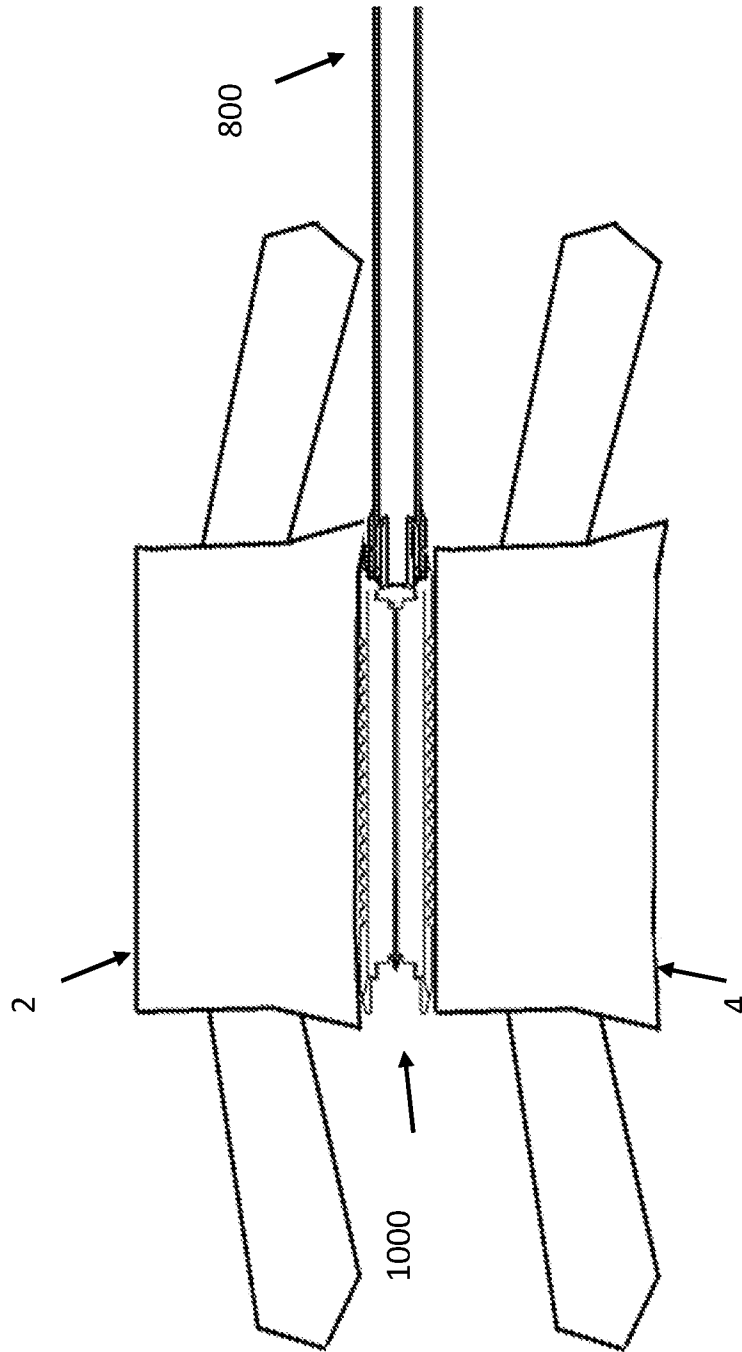

FIG. 35

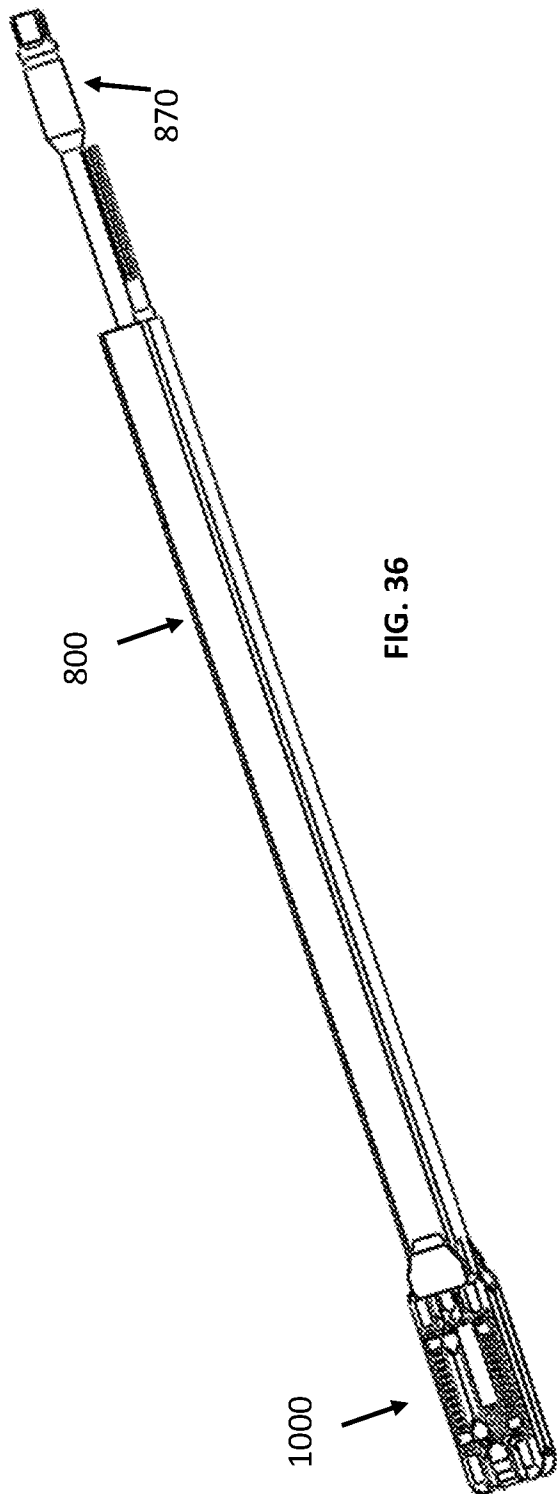

FIG. 36

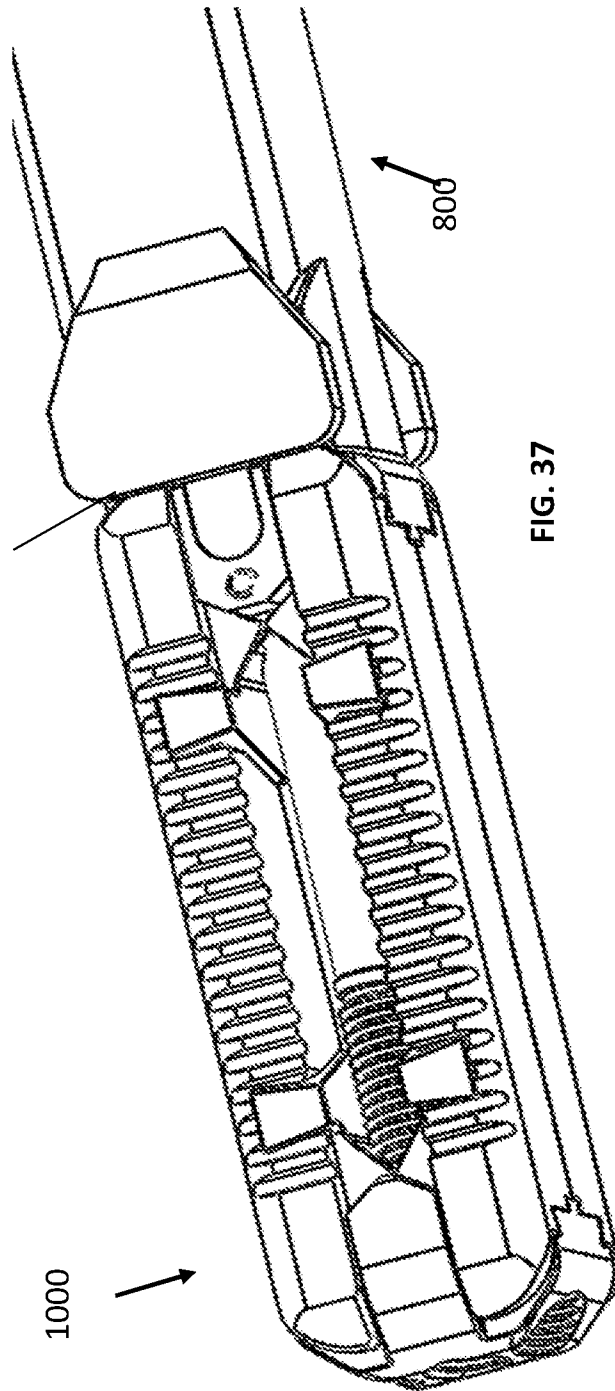
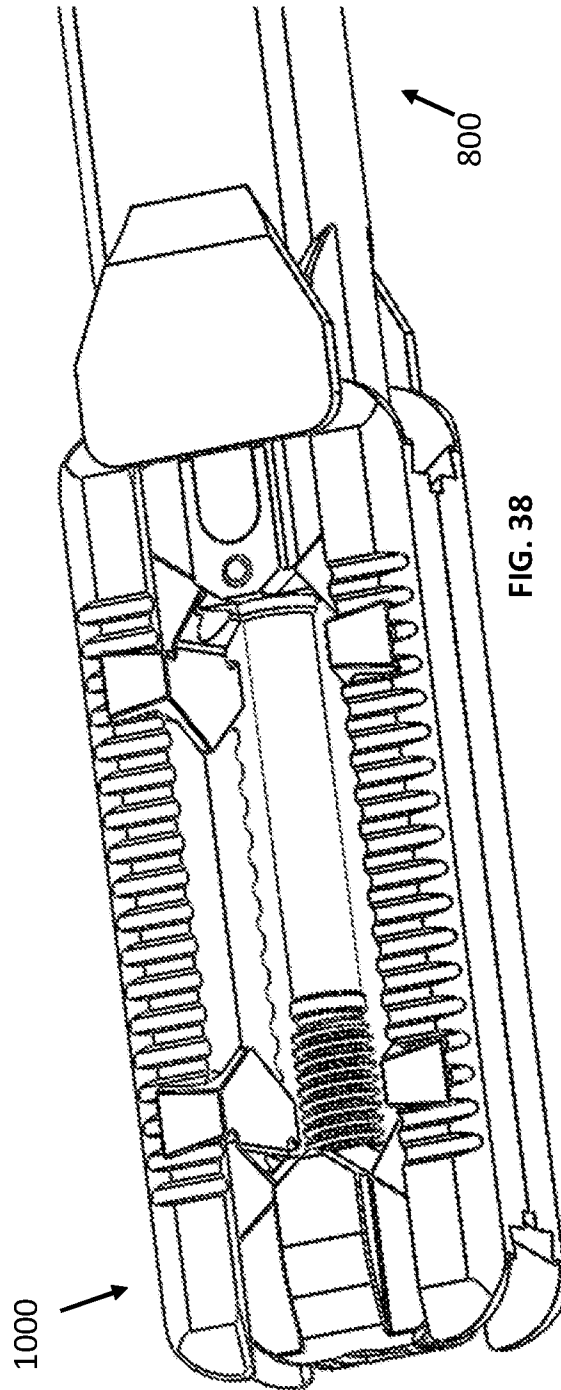
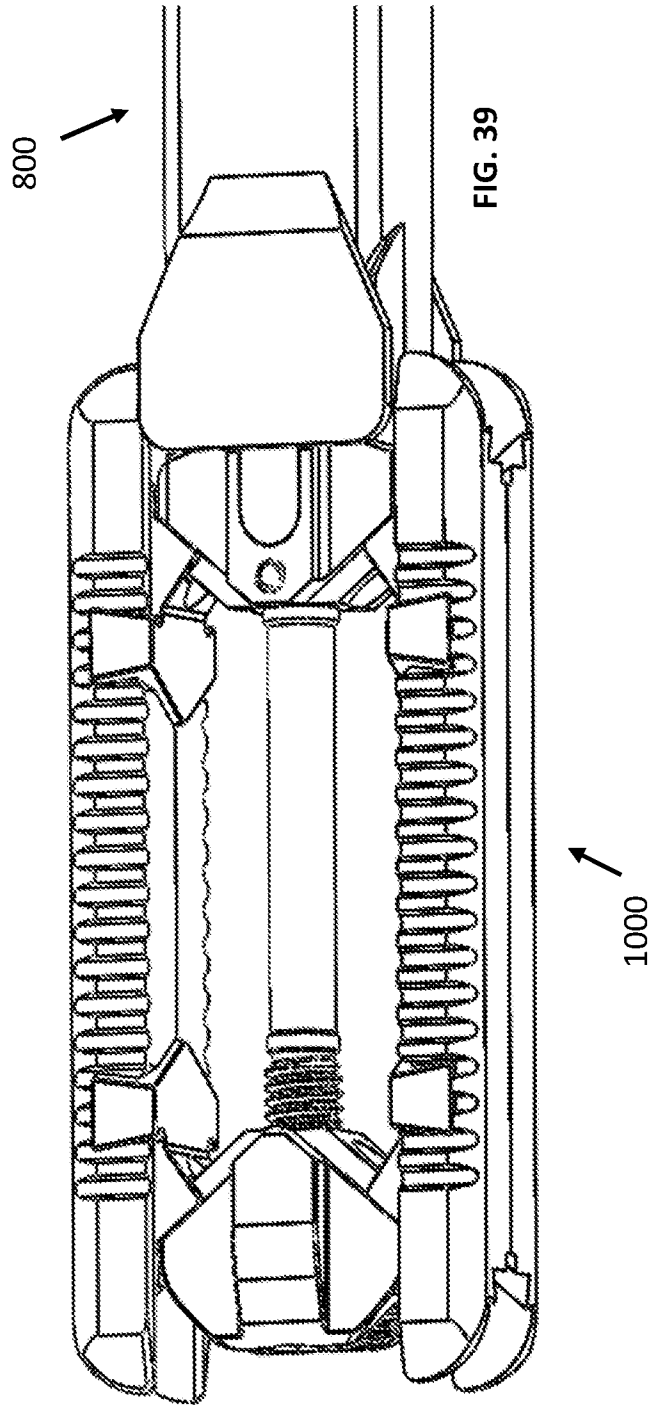

FIG. 37





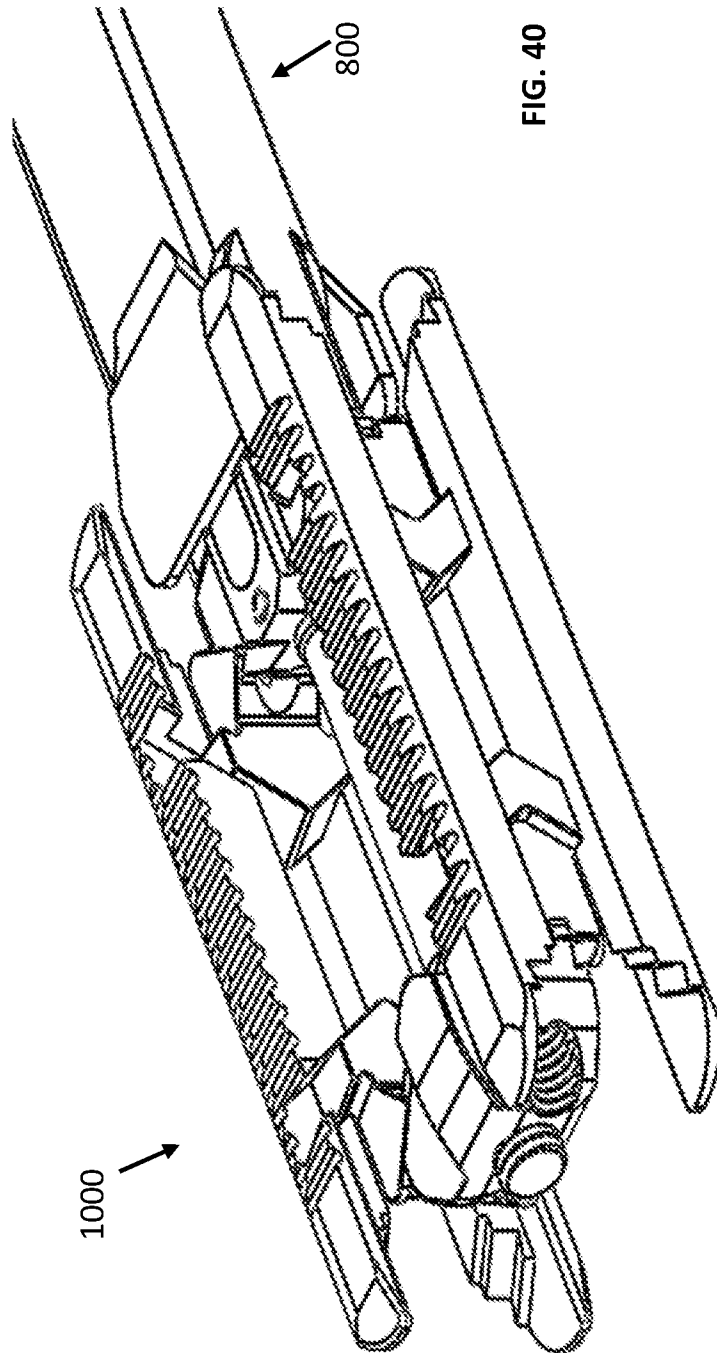

FIG. 40

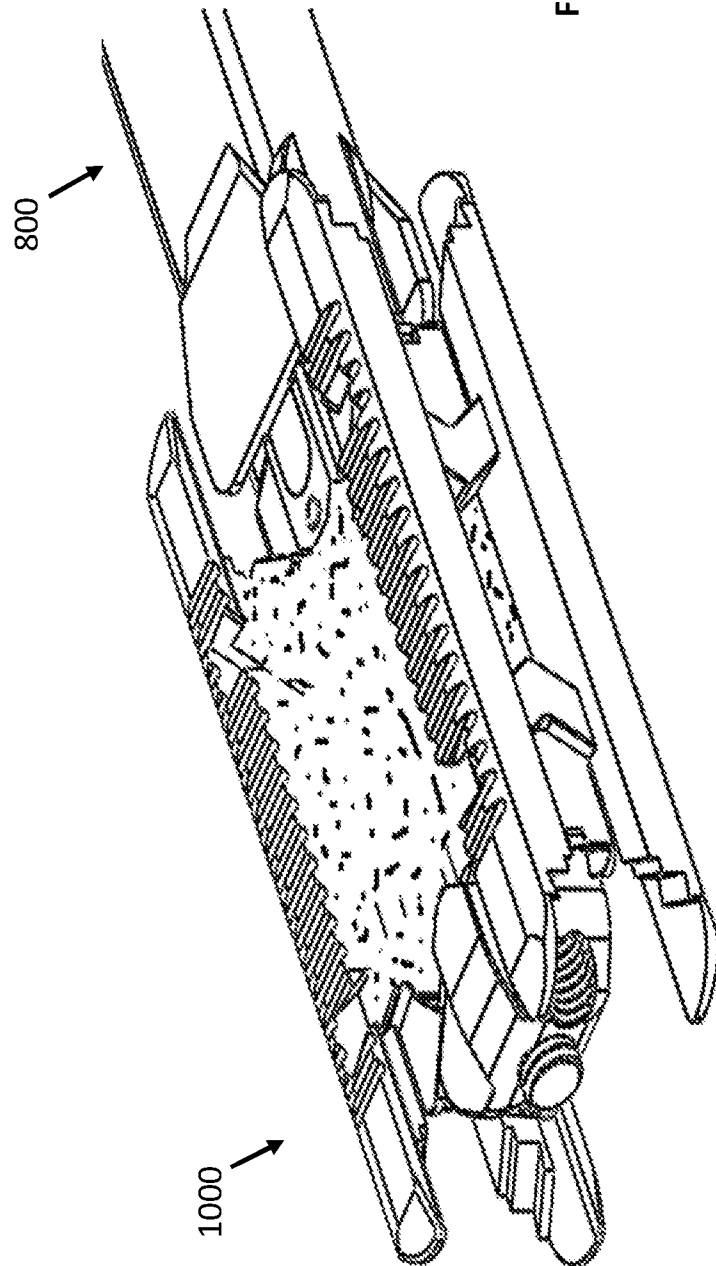
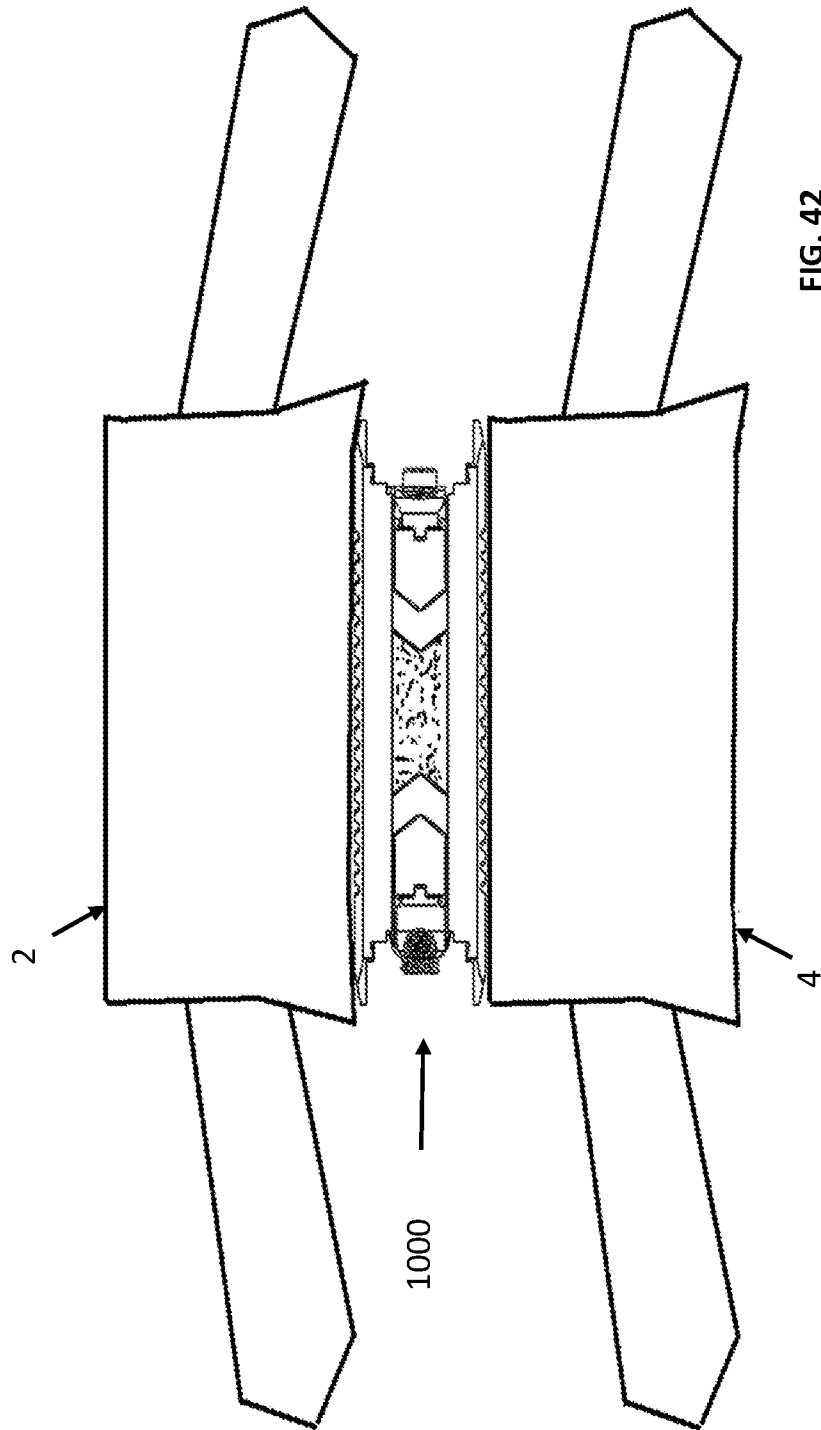

FIG. 41



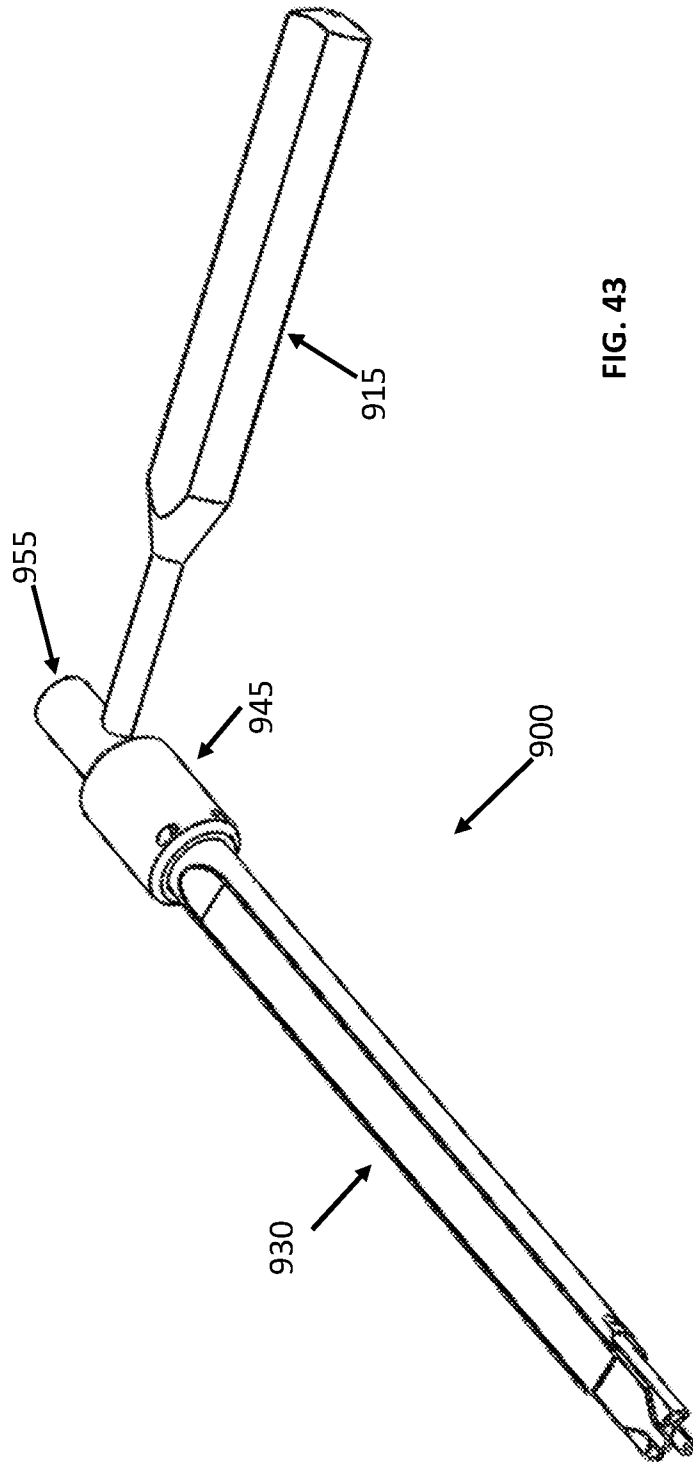

FIG. 43

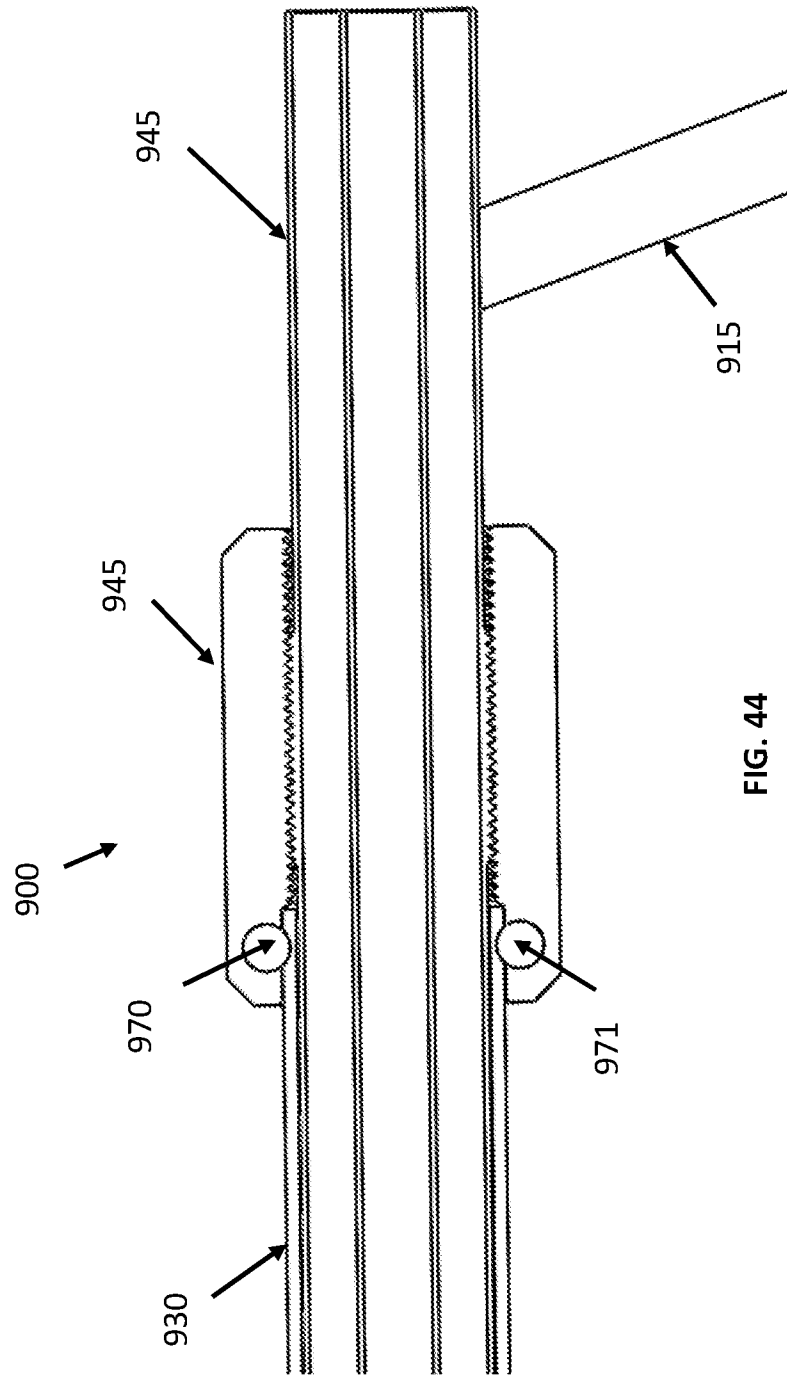
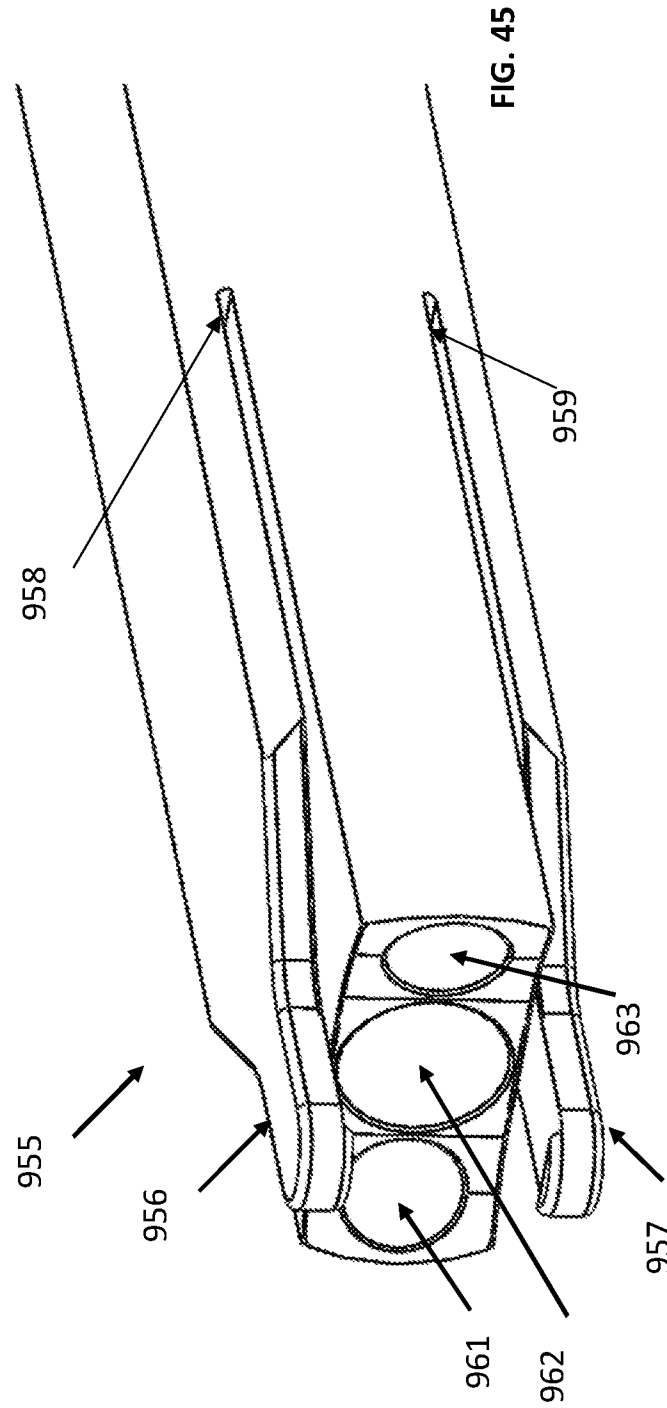
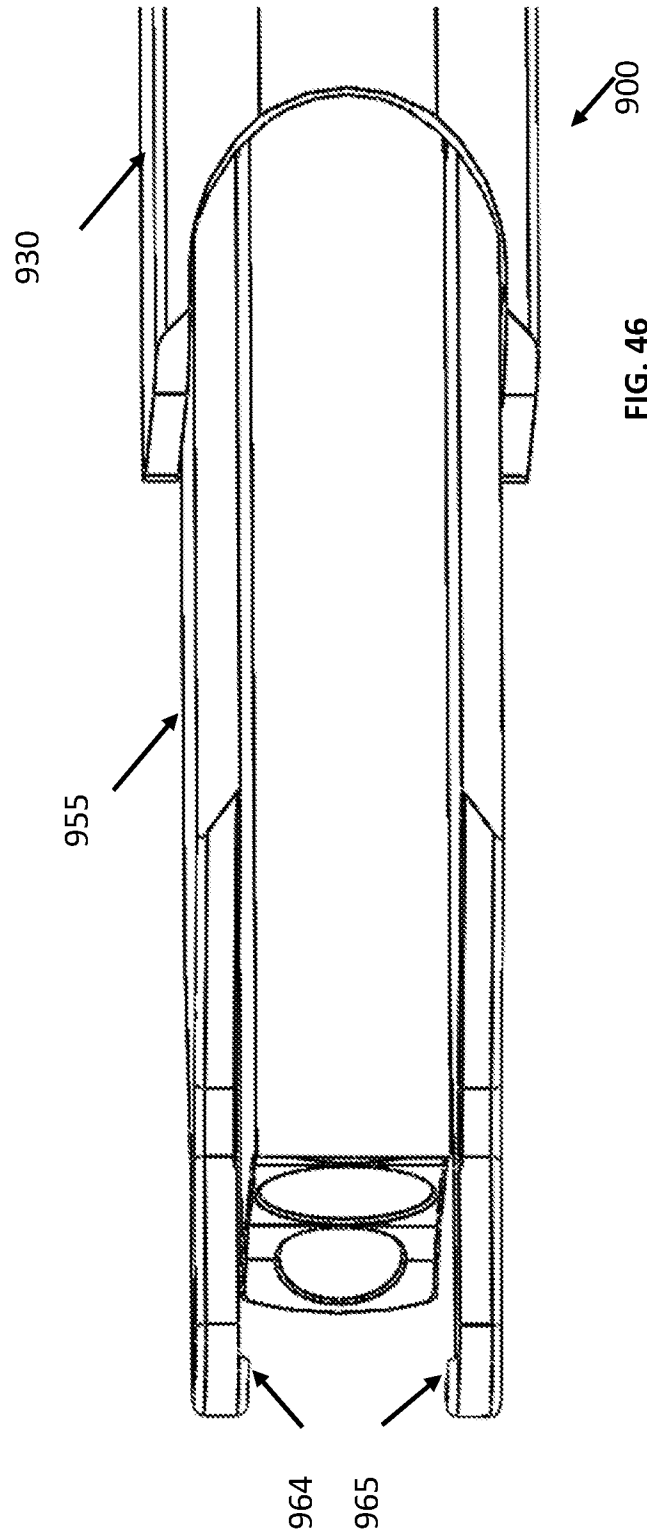
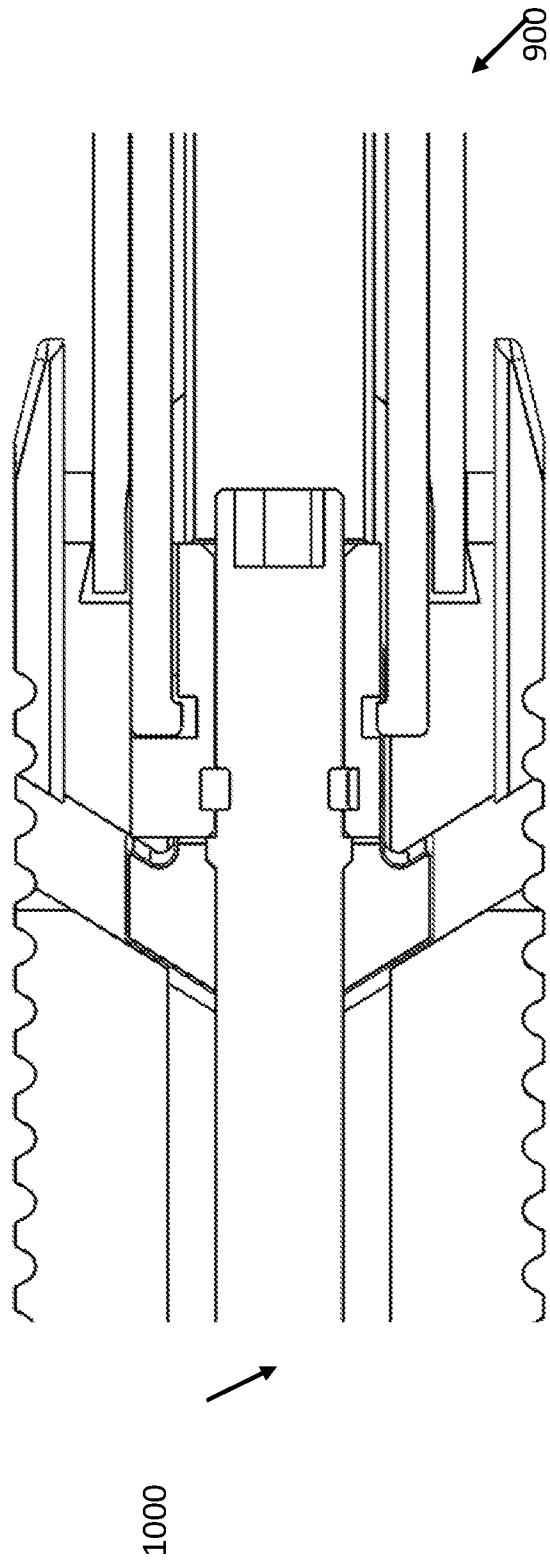

FIG. 44







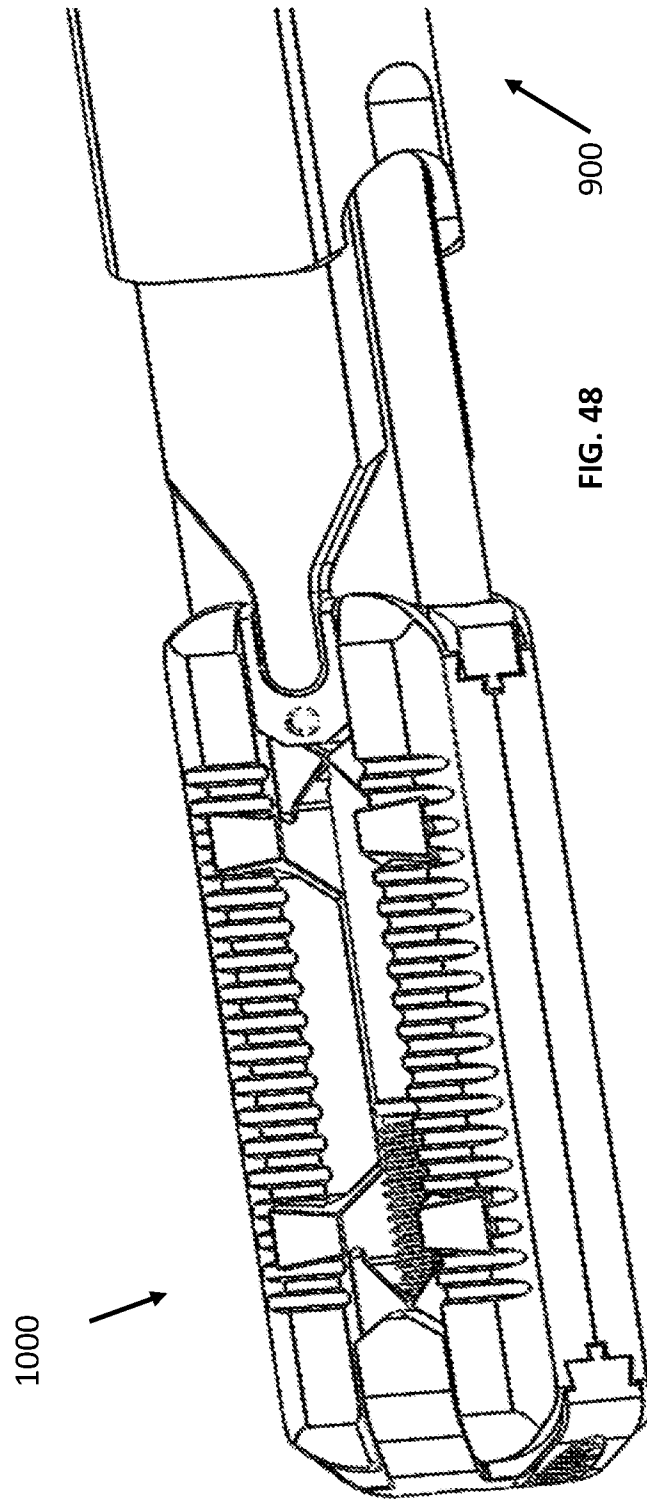

FIG. 48

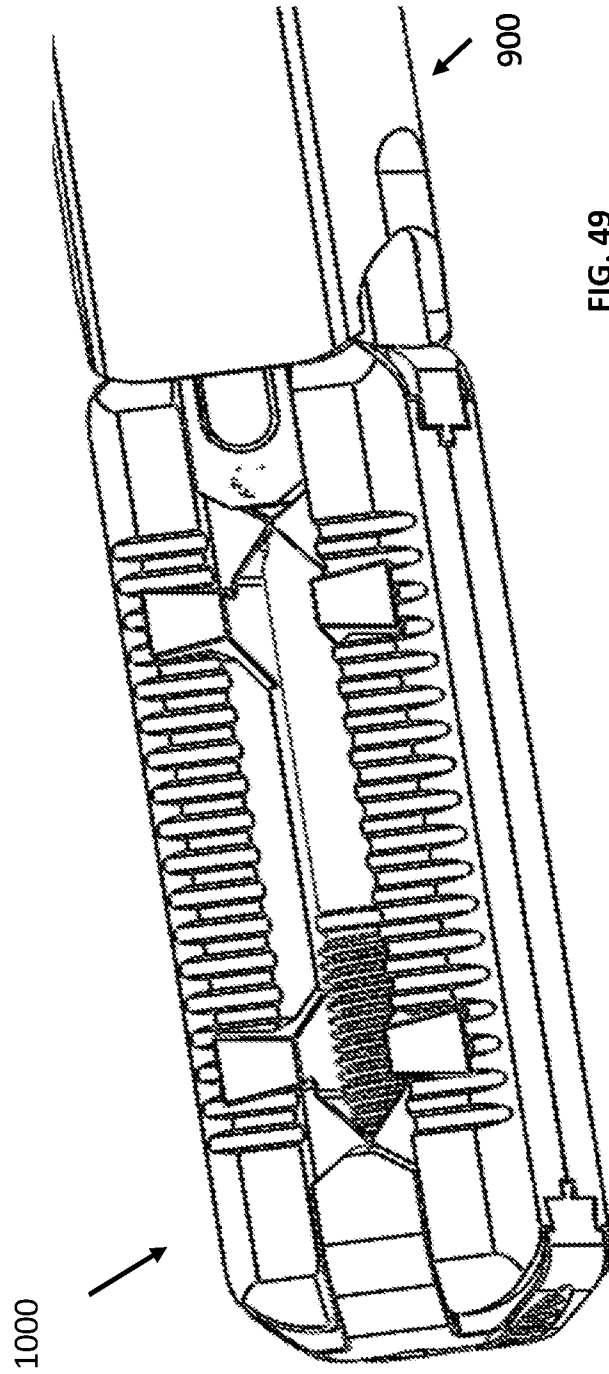

FIG. 49

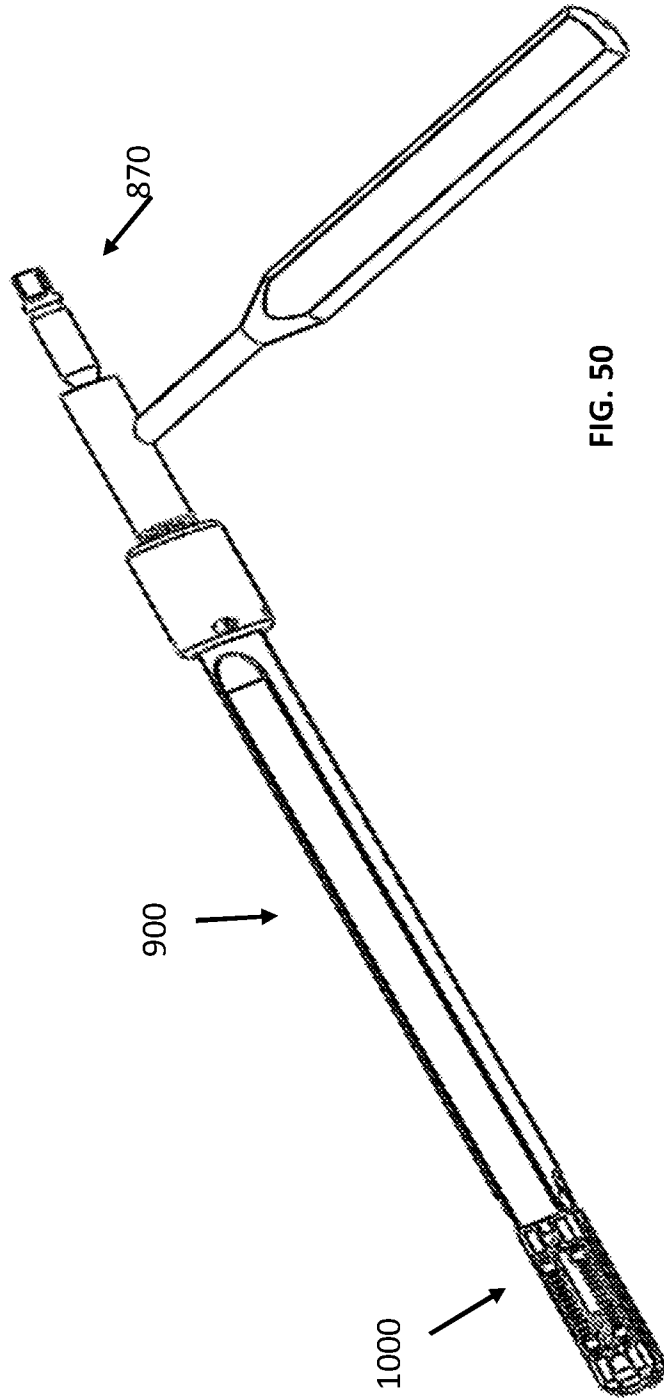
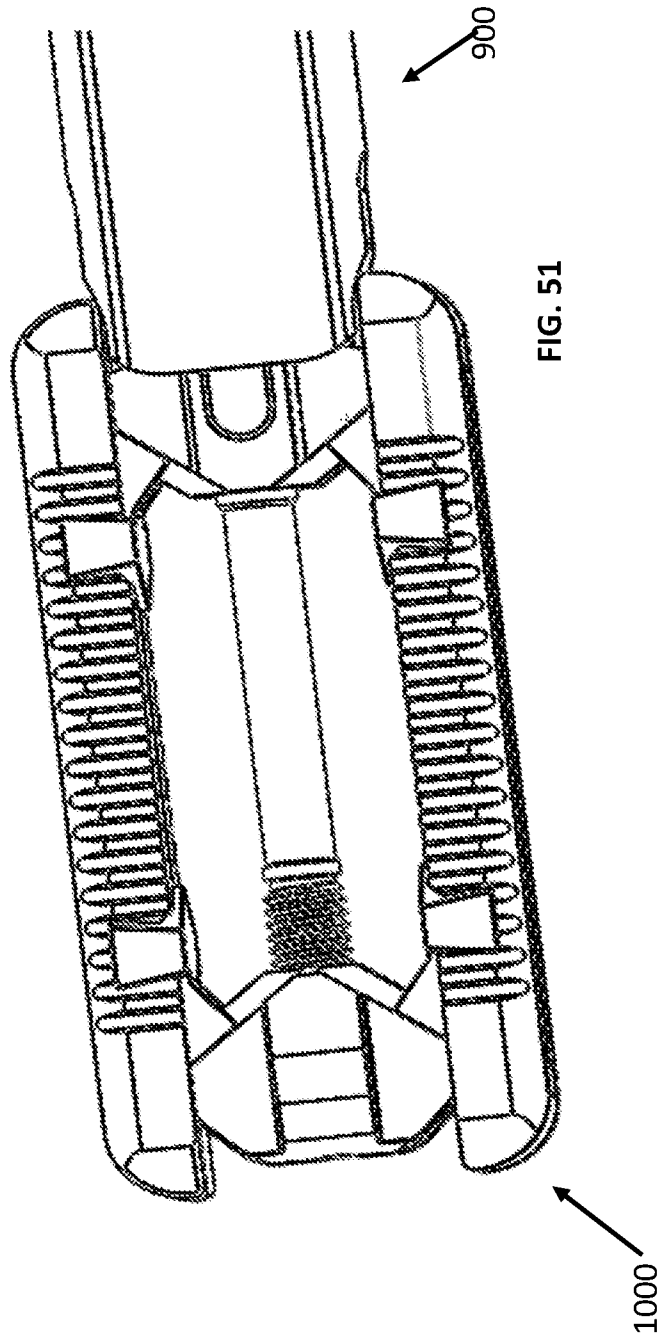

FIG. 50



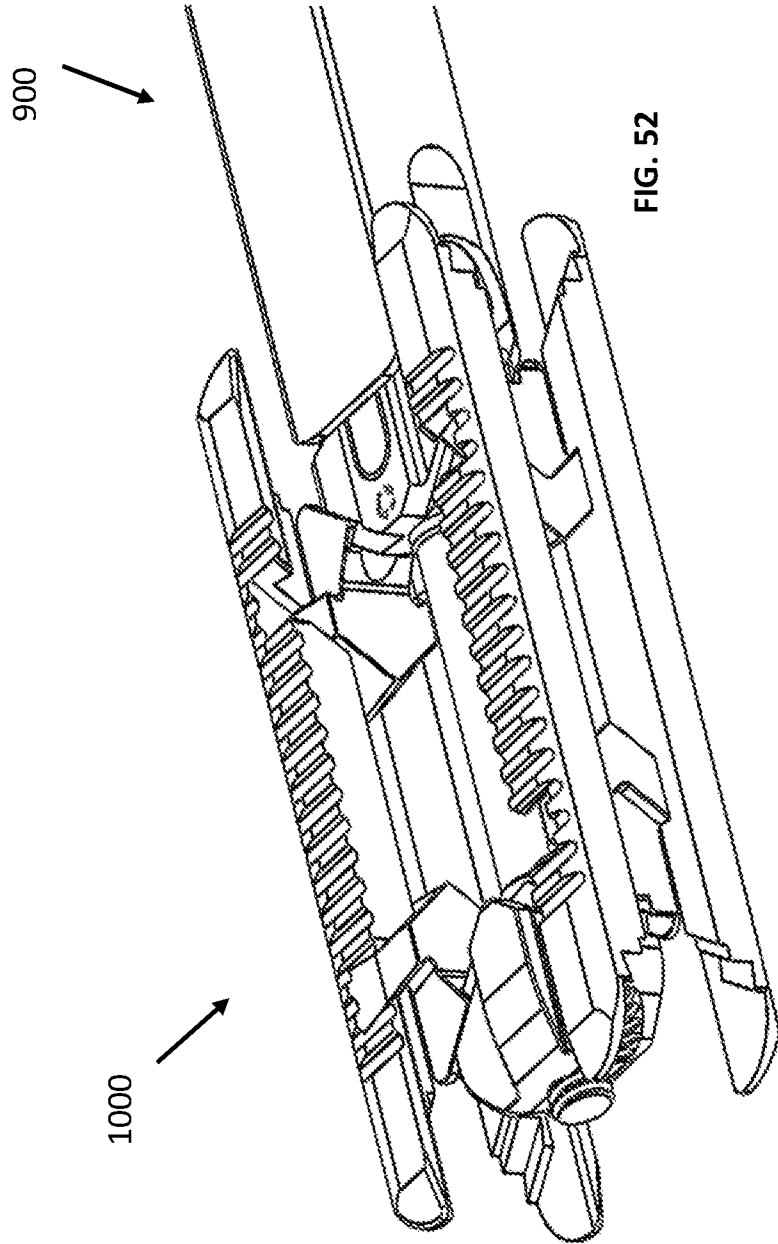
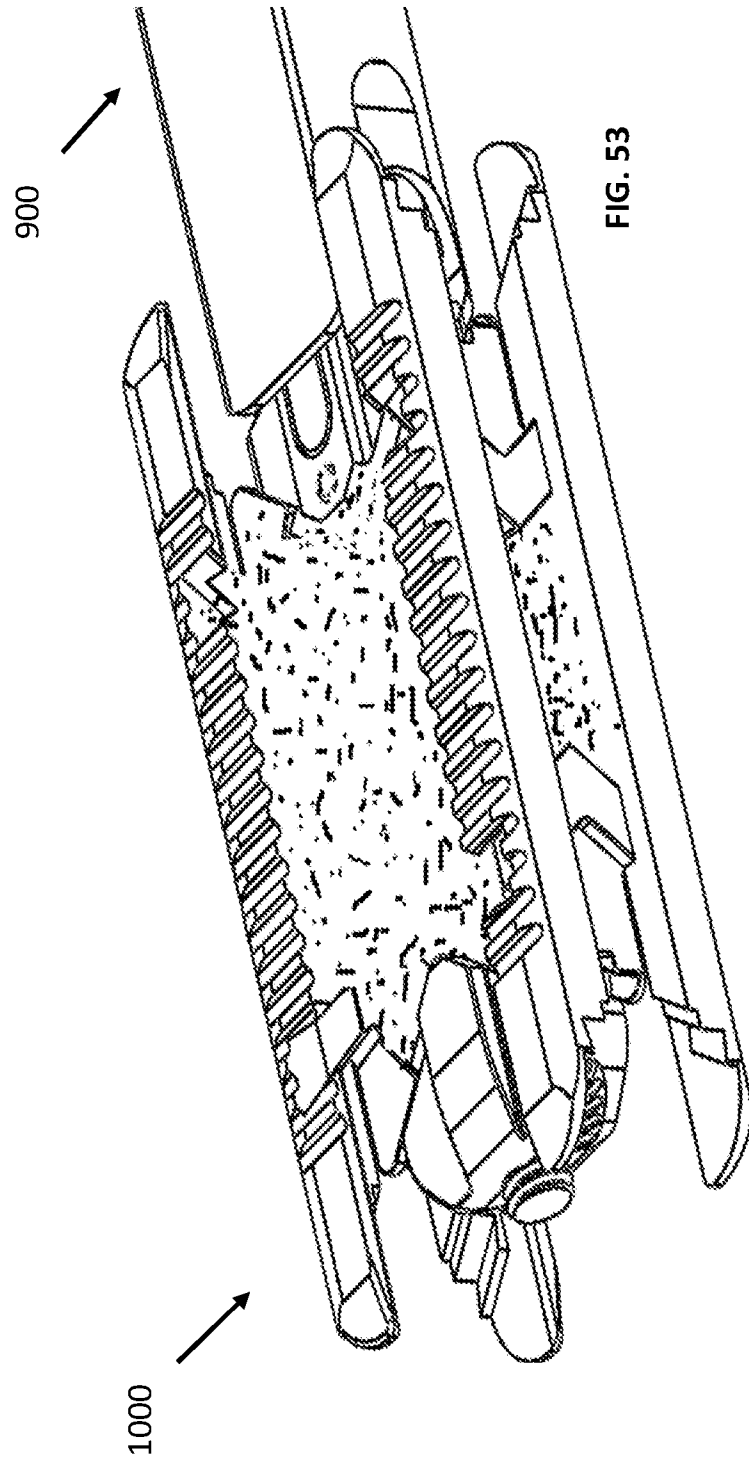

FIG. 52



1000a

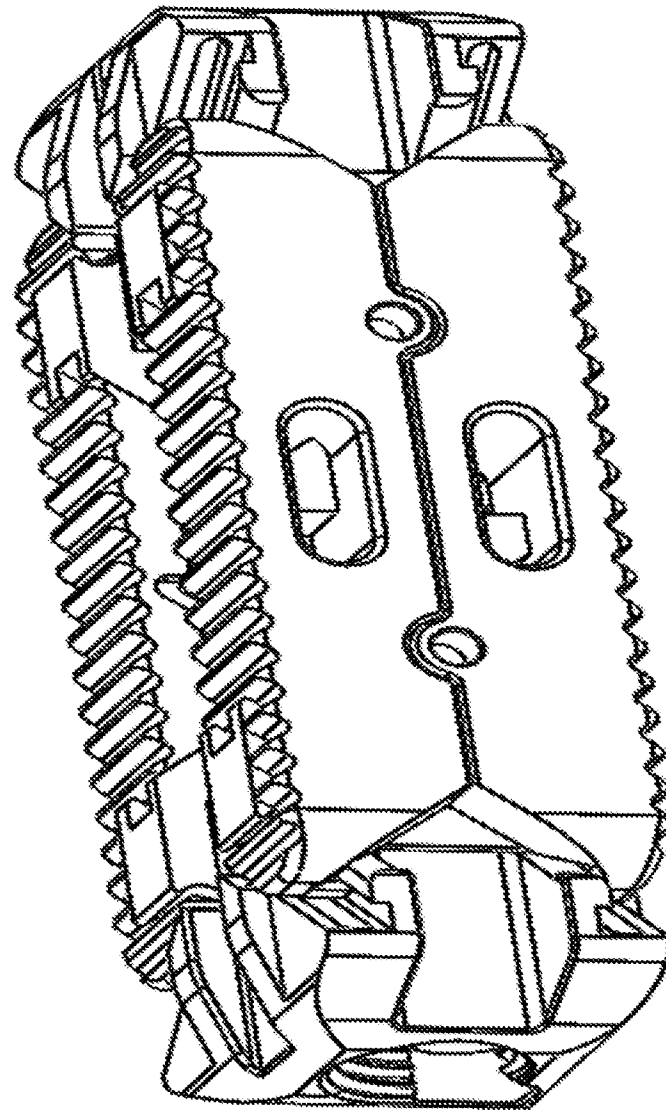

FIG. 54A

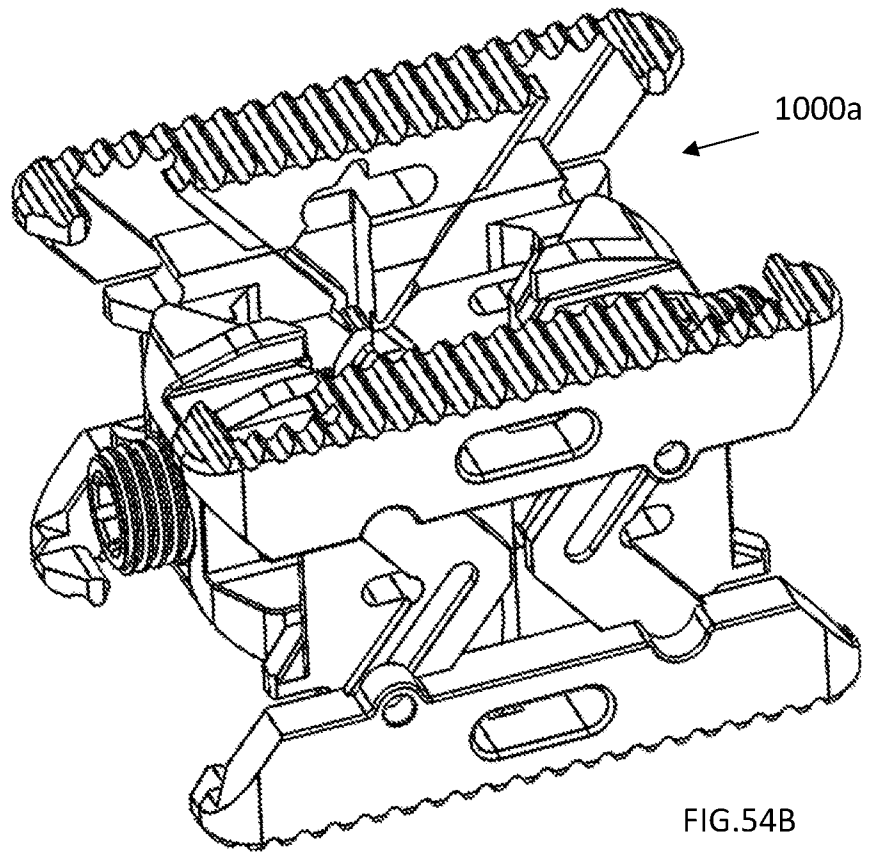

FIG.54B

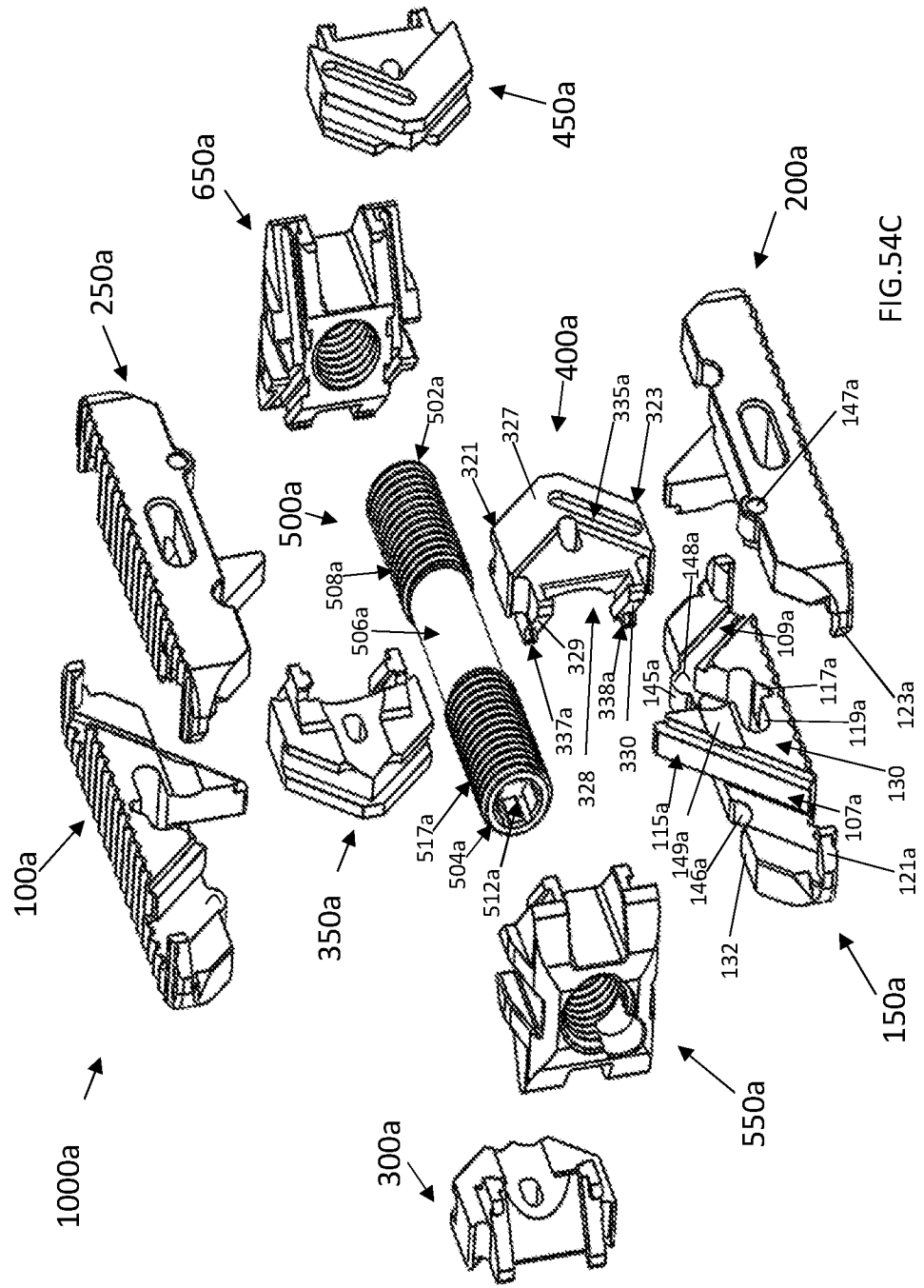

FIG.54C

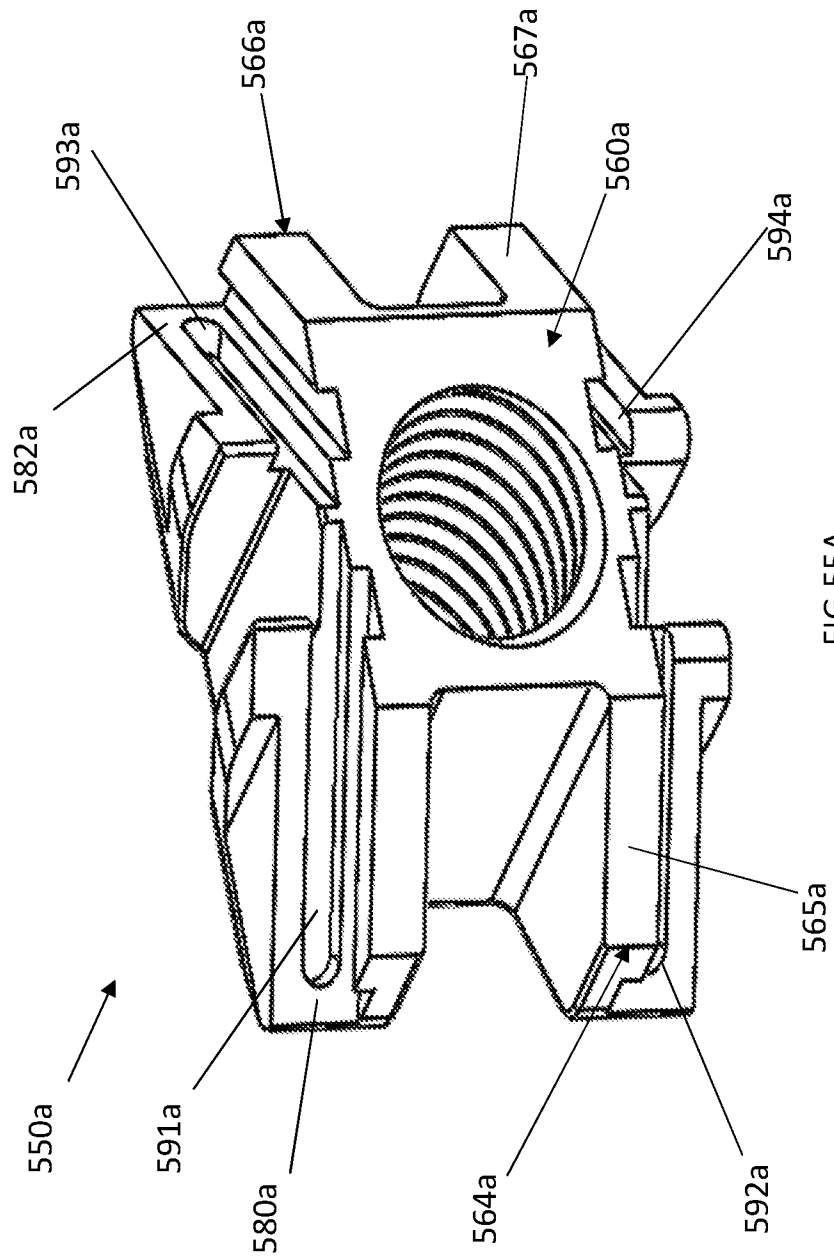

FIG. 55A

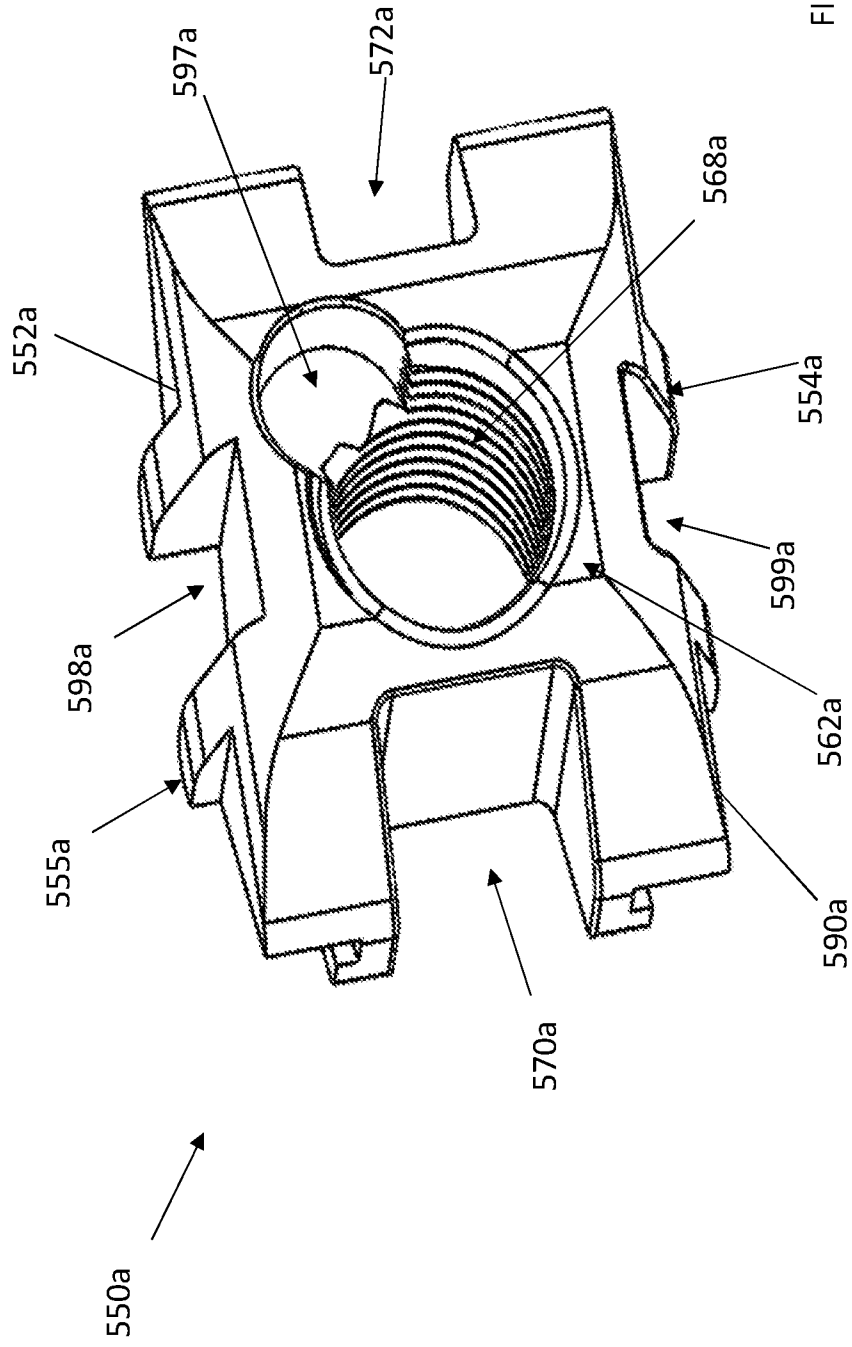

FIG. 55B

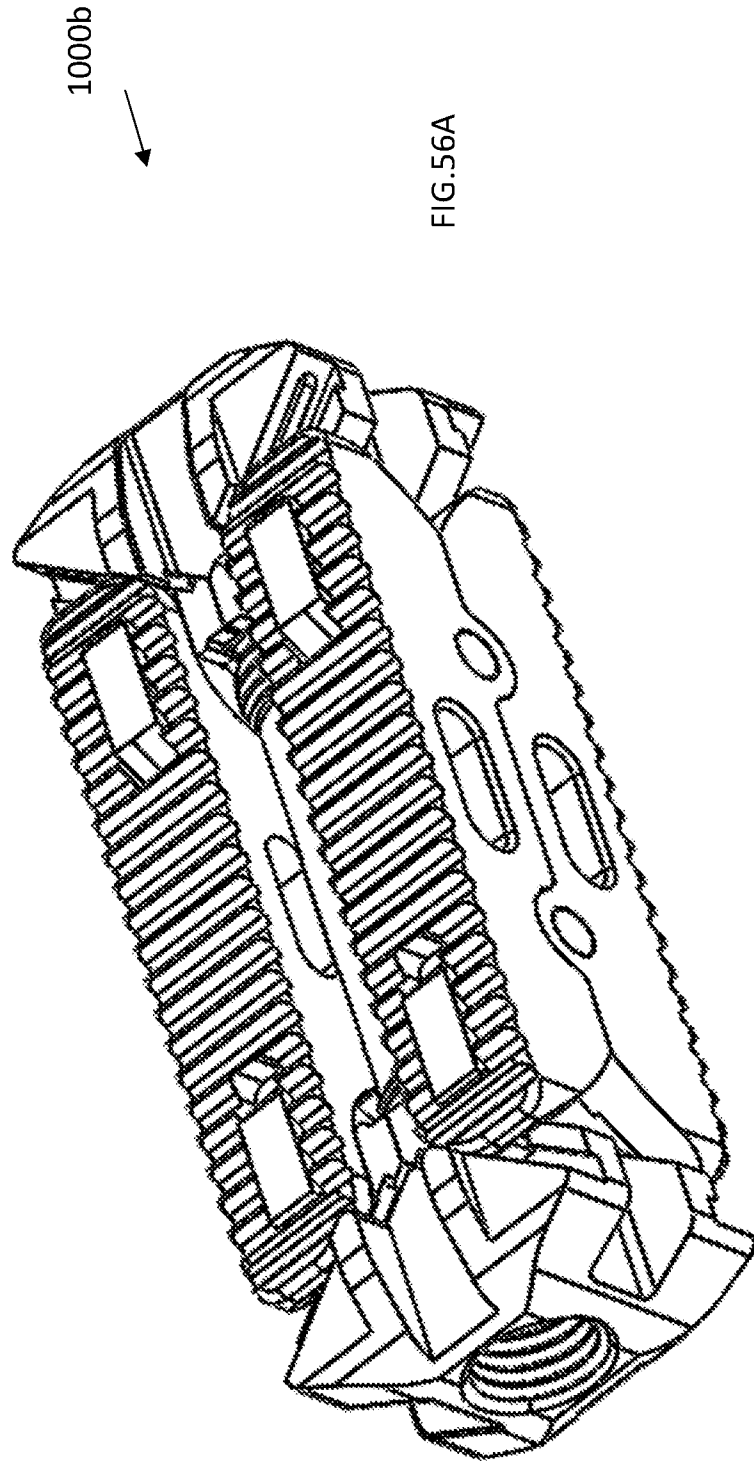

FIG.56A

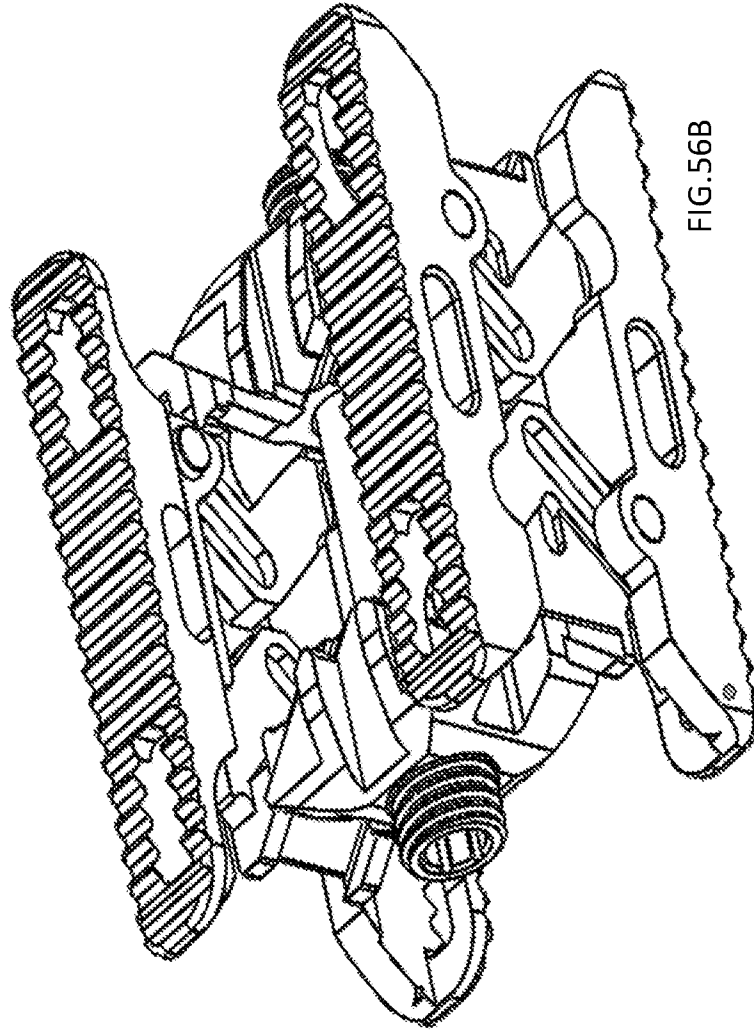

FIG. 56B

1000b



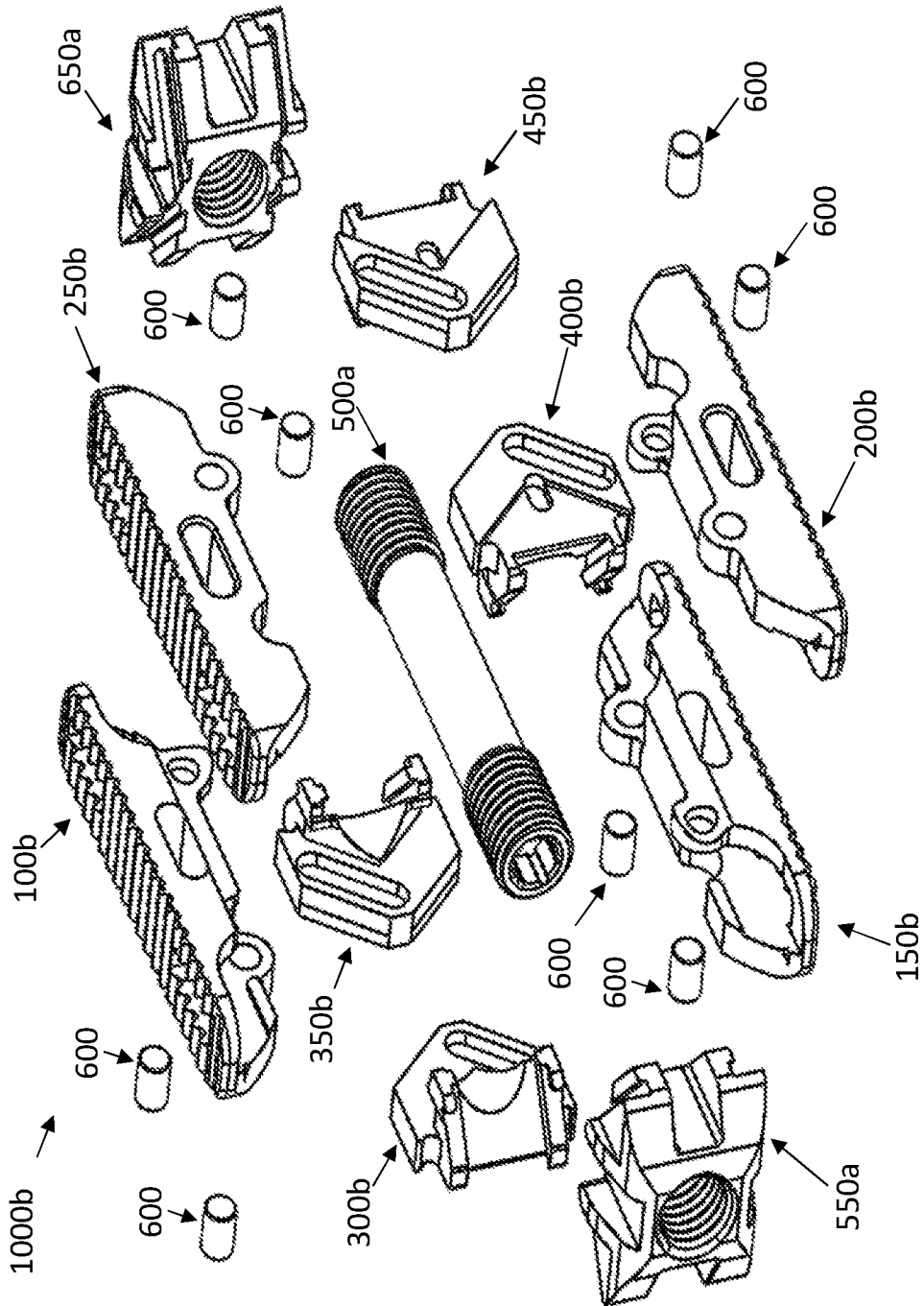

FIG.56C

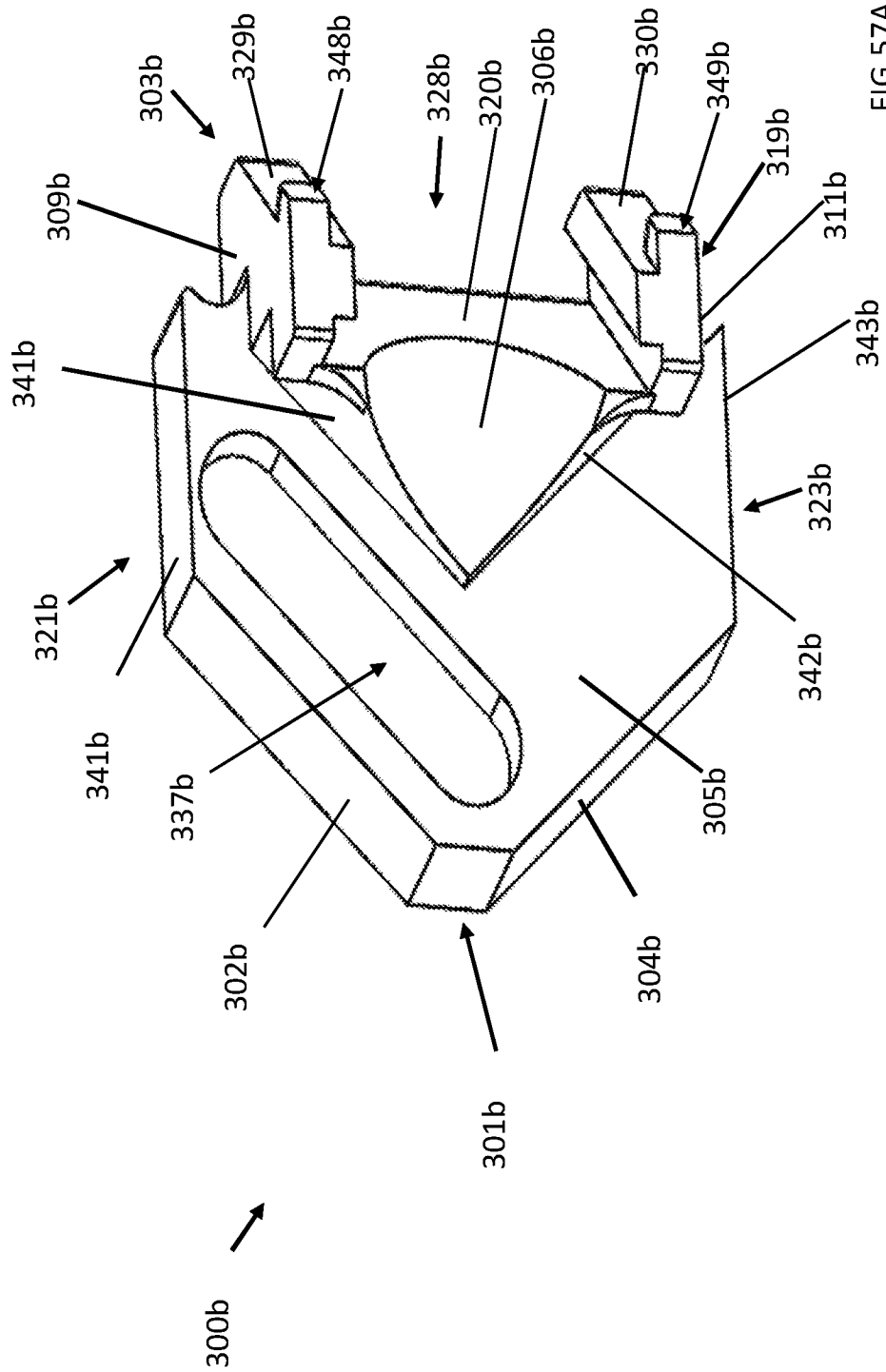

FIG. 57A

118b

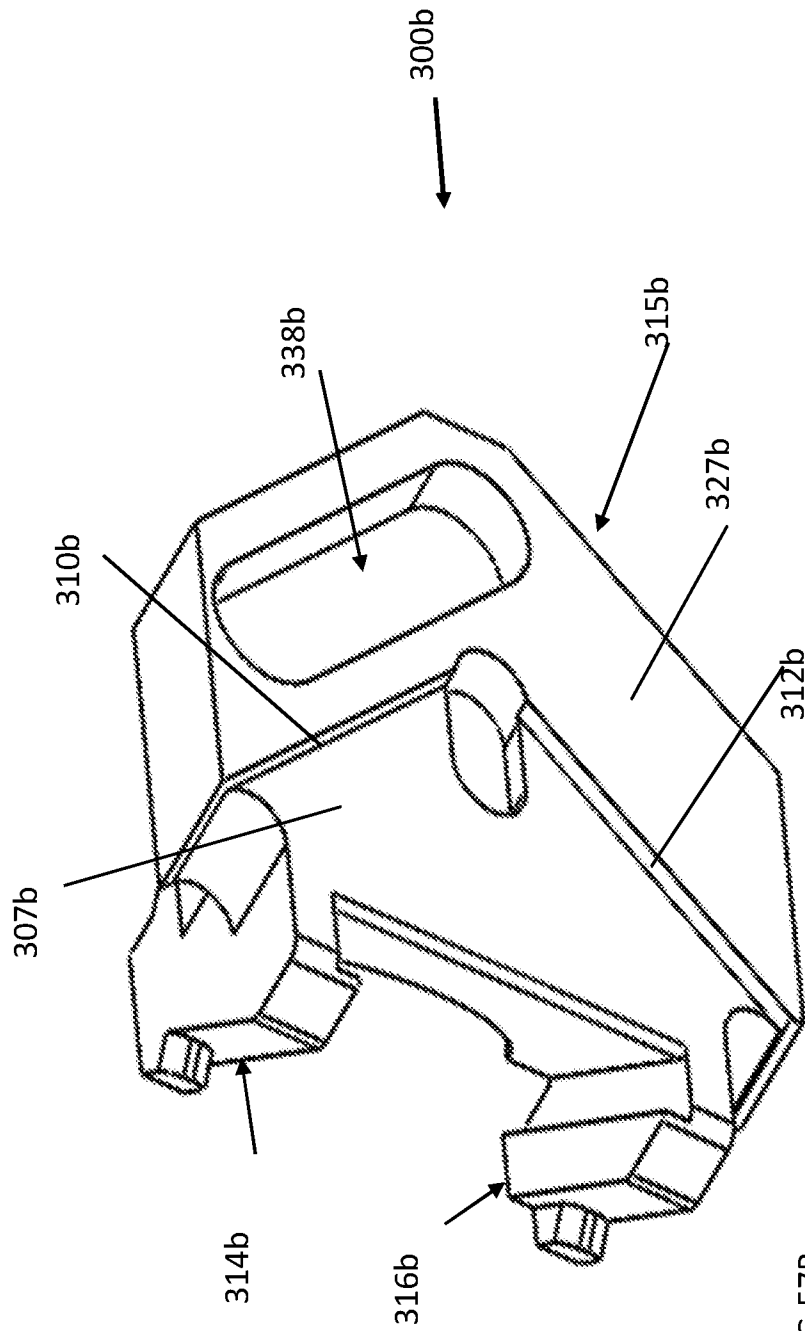

FIG. 57B

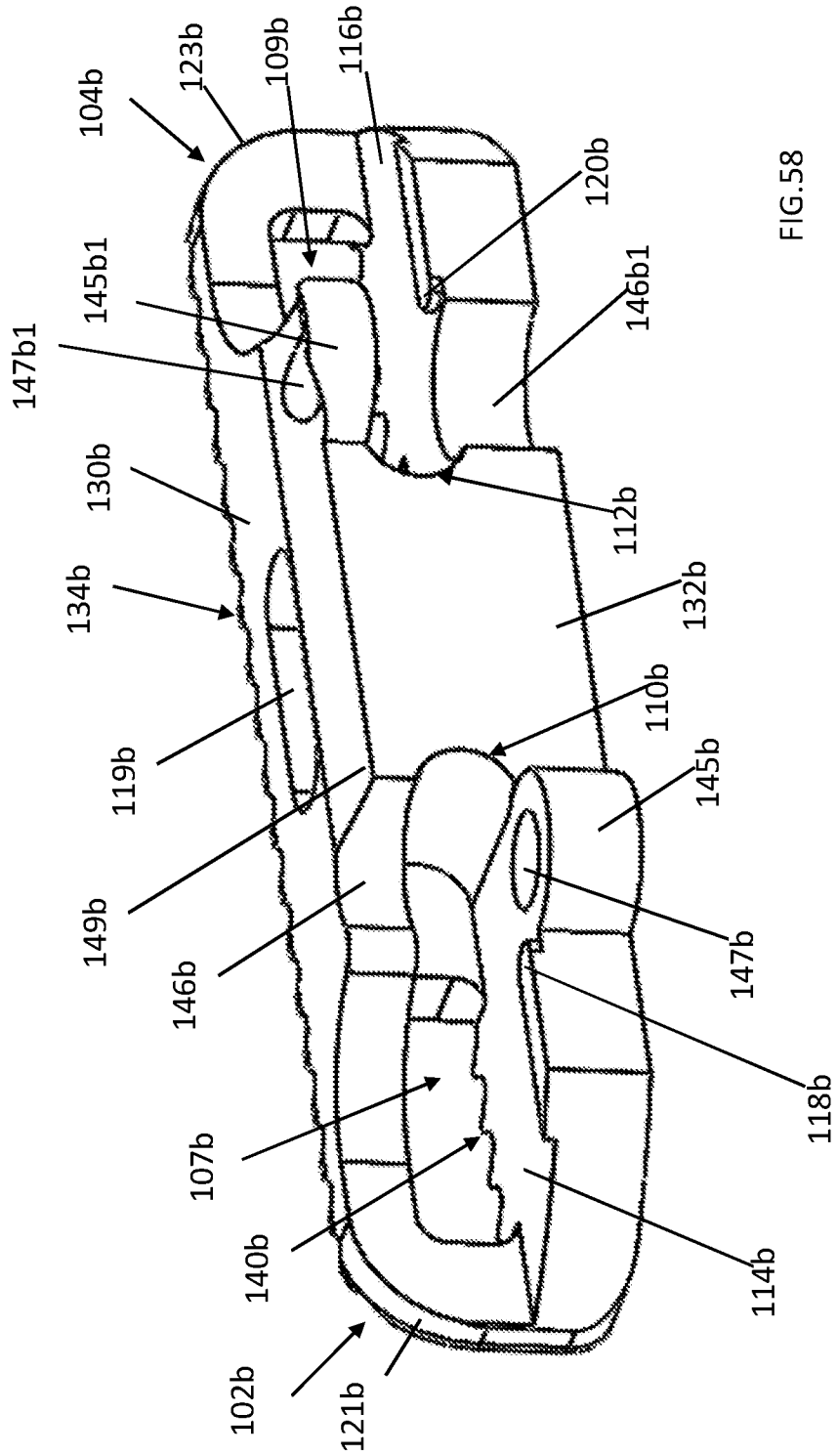
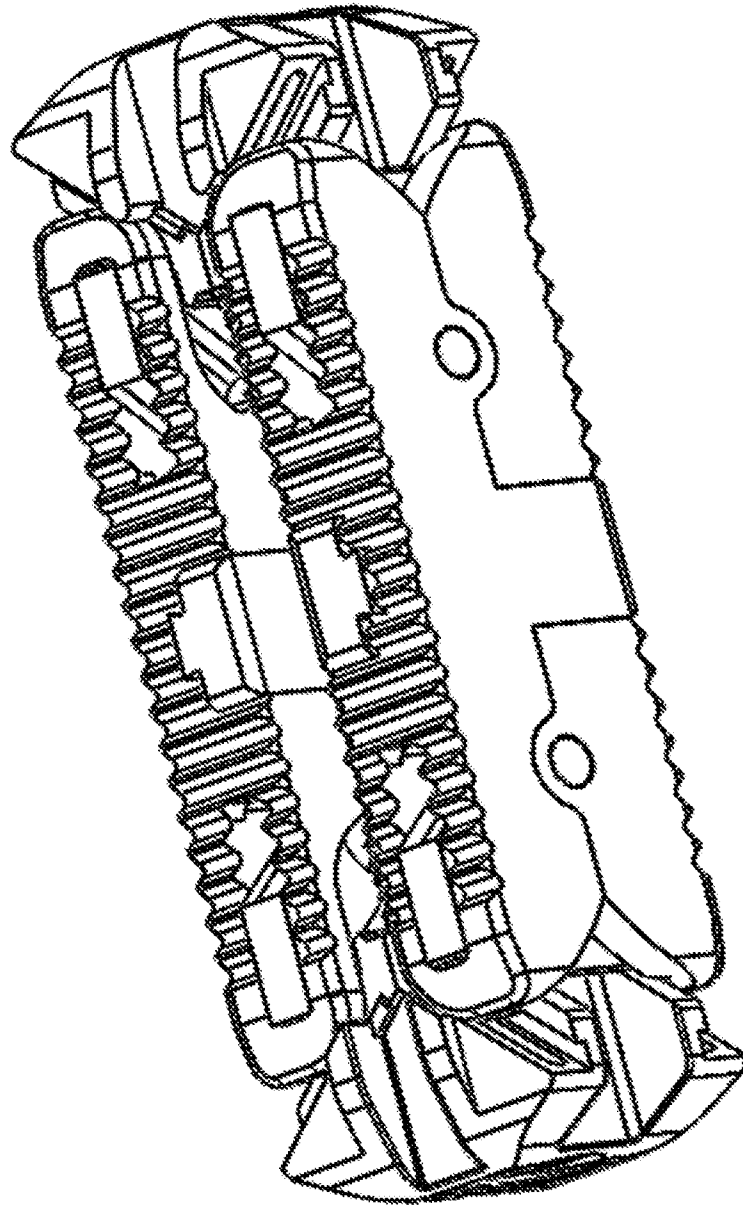

FIG.58

1000c

FIG. 59A



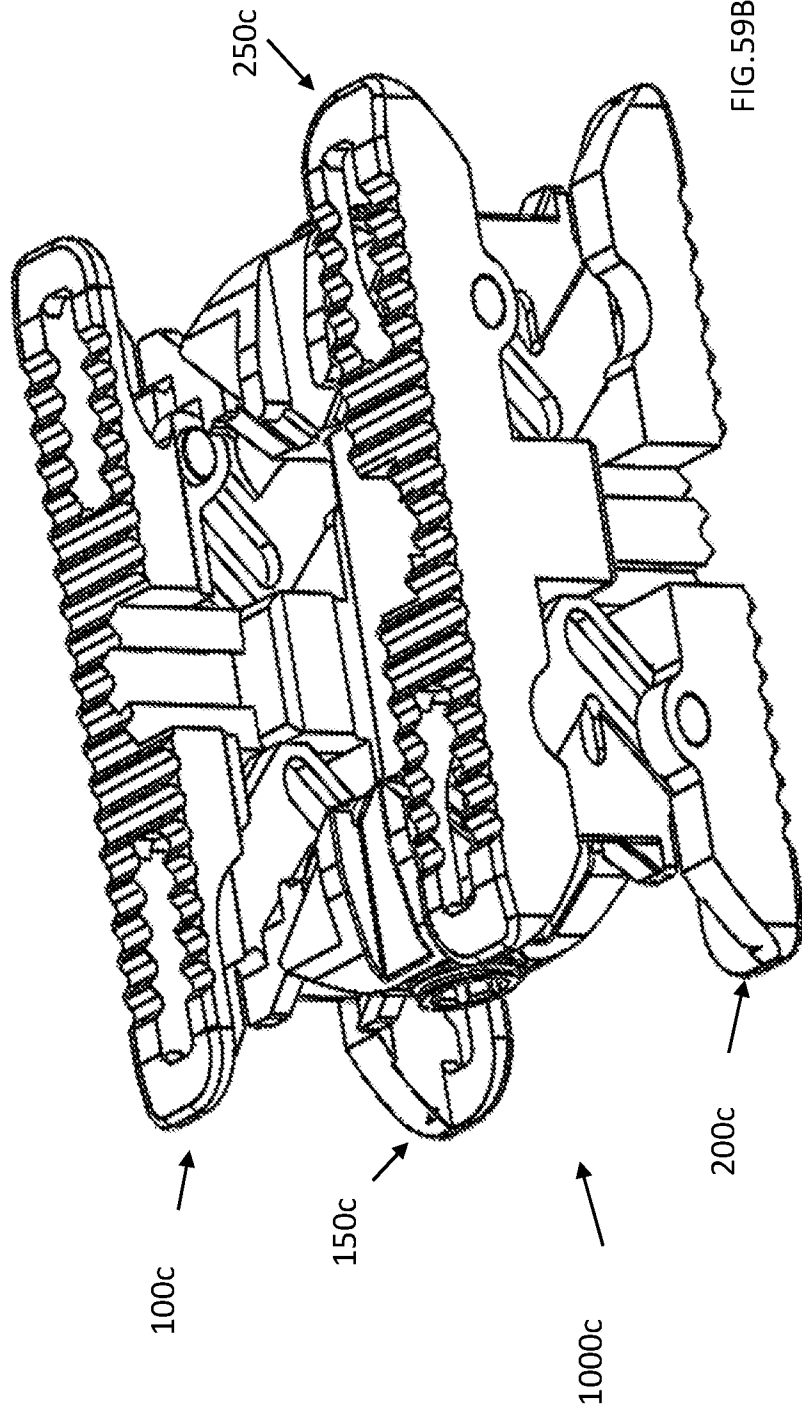
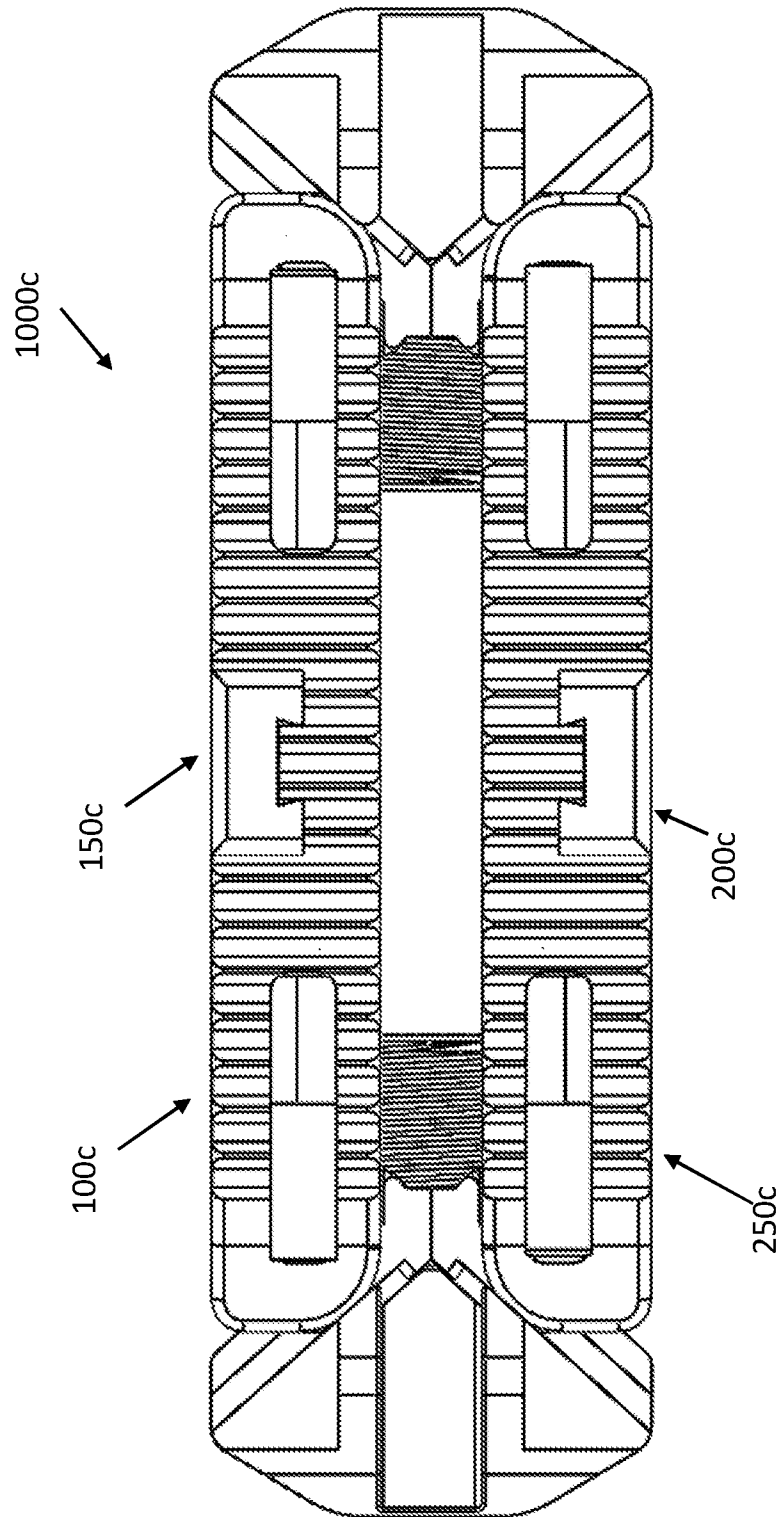

FIG. 59B



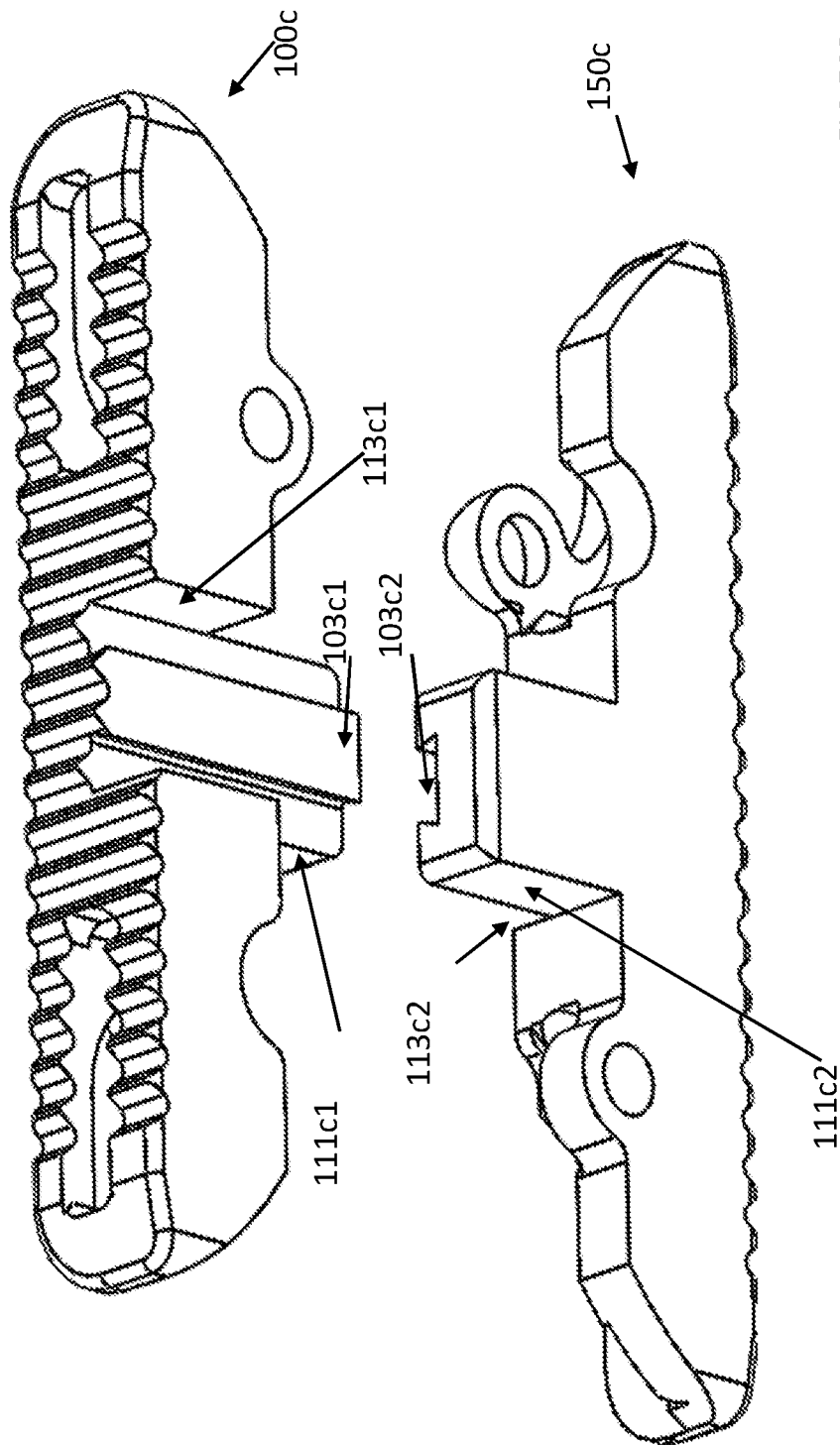

FIG. 59D

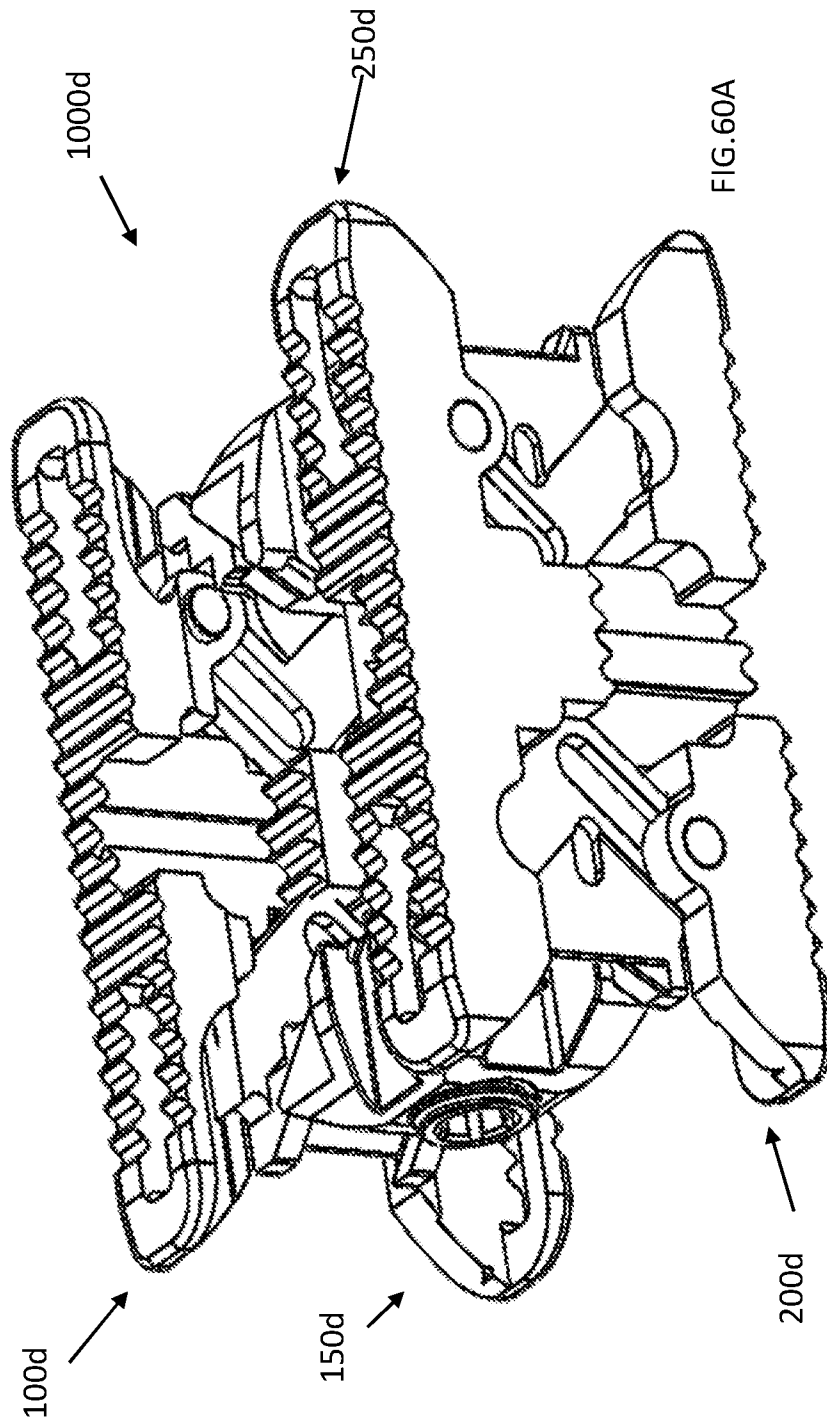

FIG. 60A

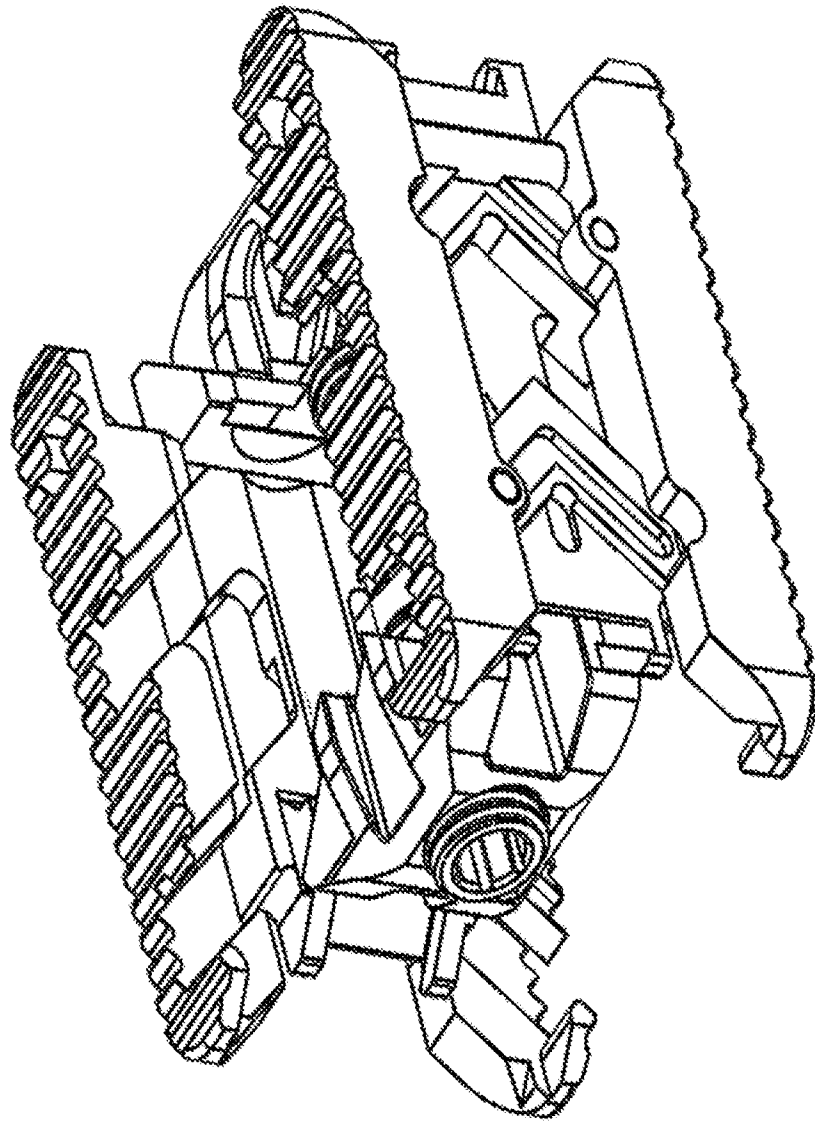

FIG. 61A

1000e

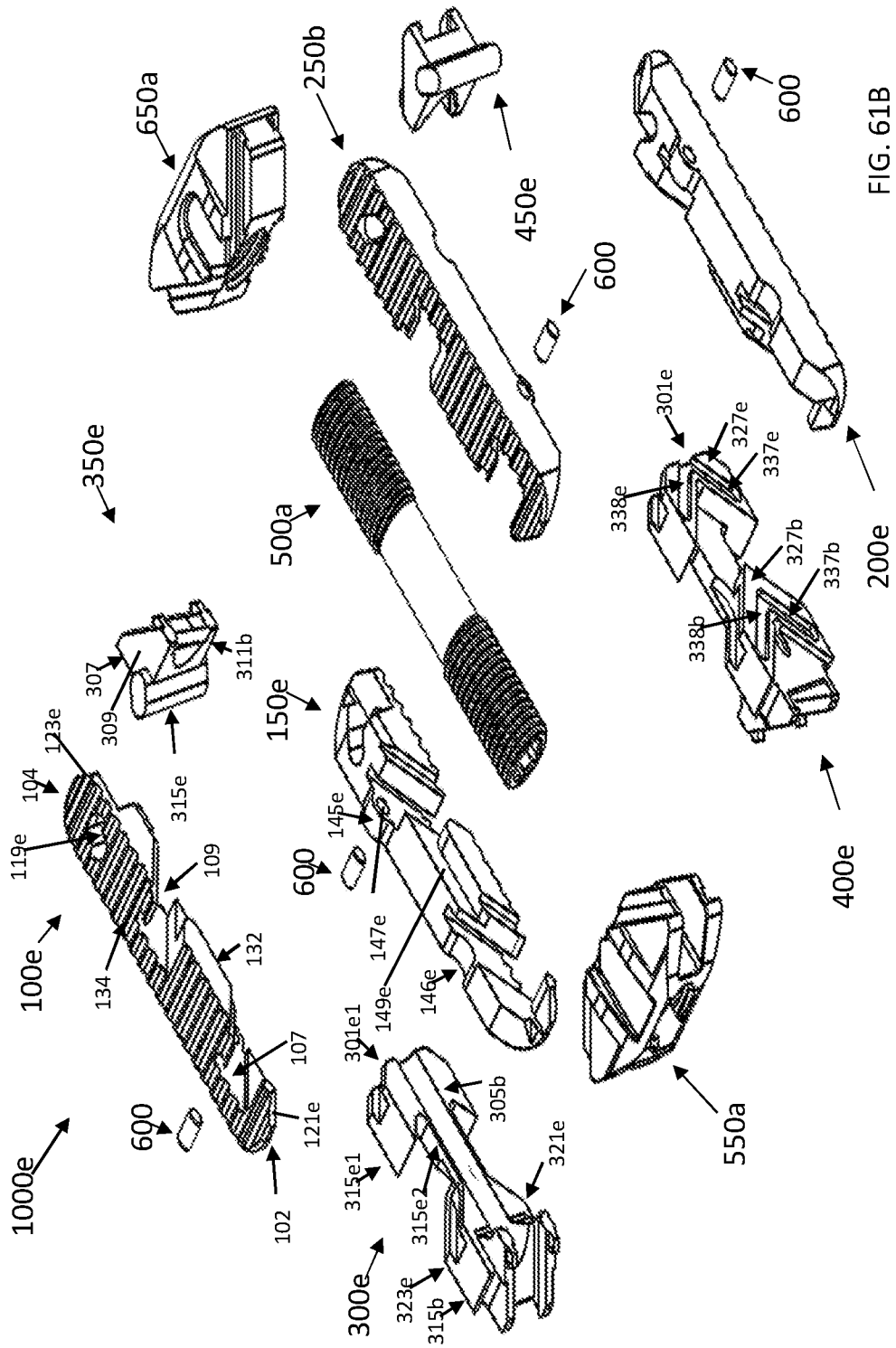
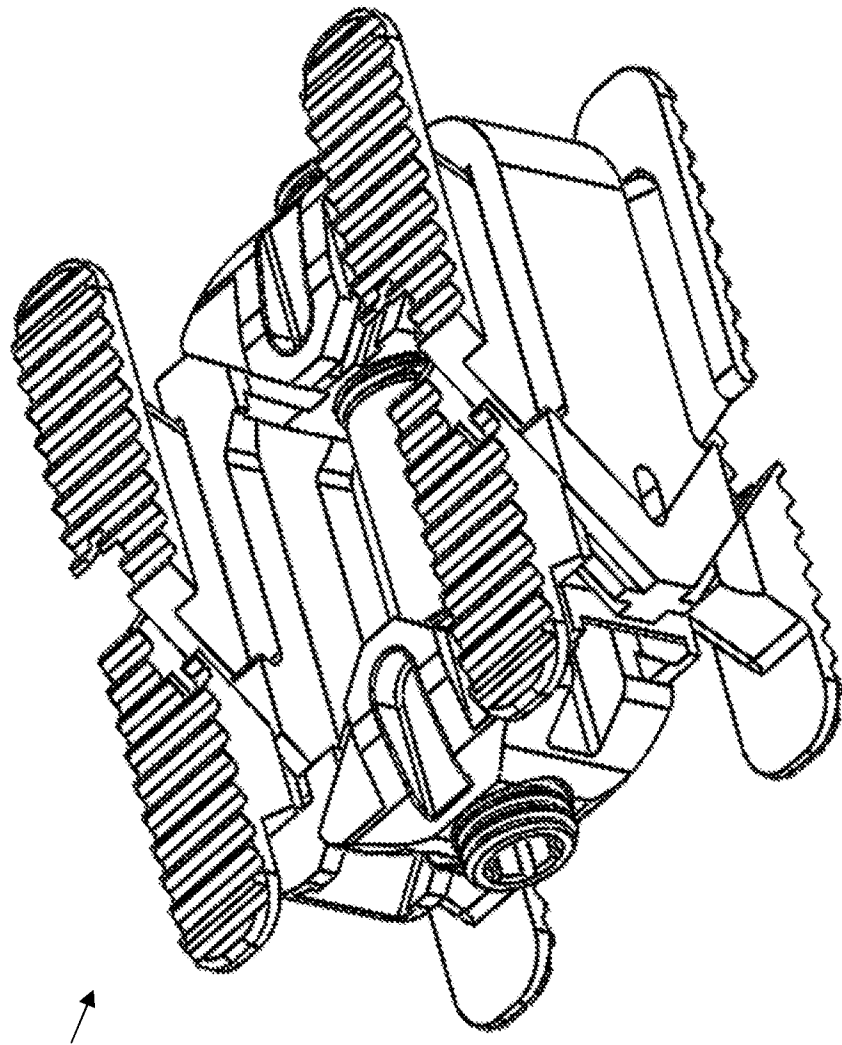

FIG. 61B

FIG. 62A



1000f



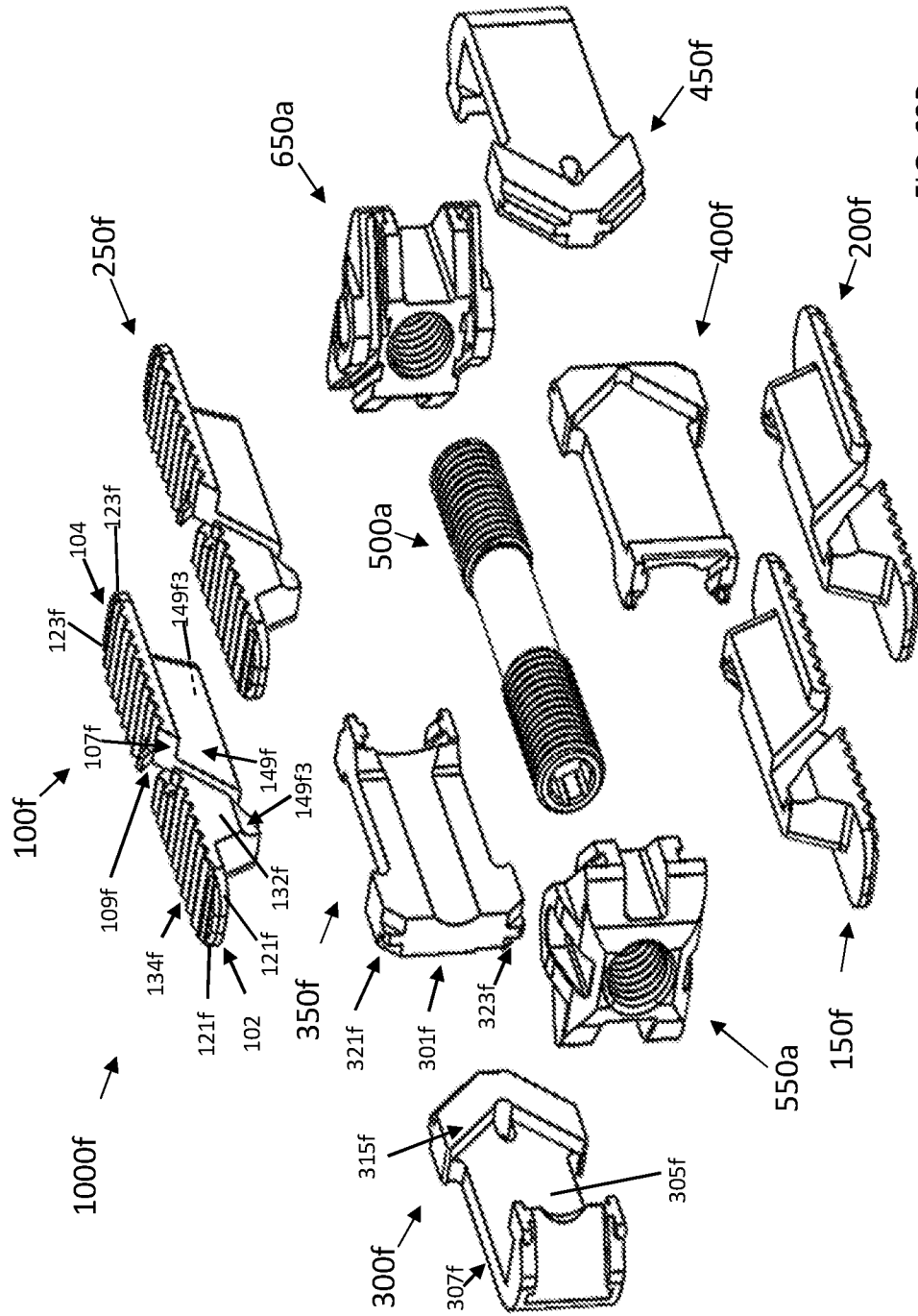
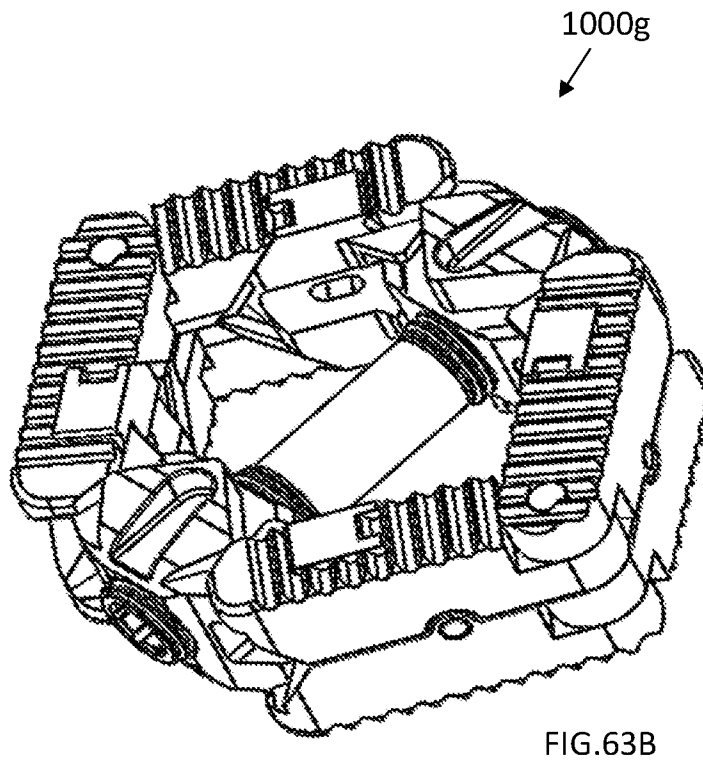
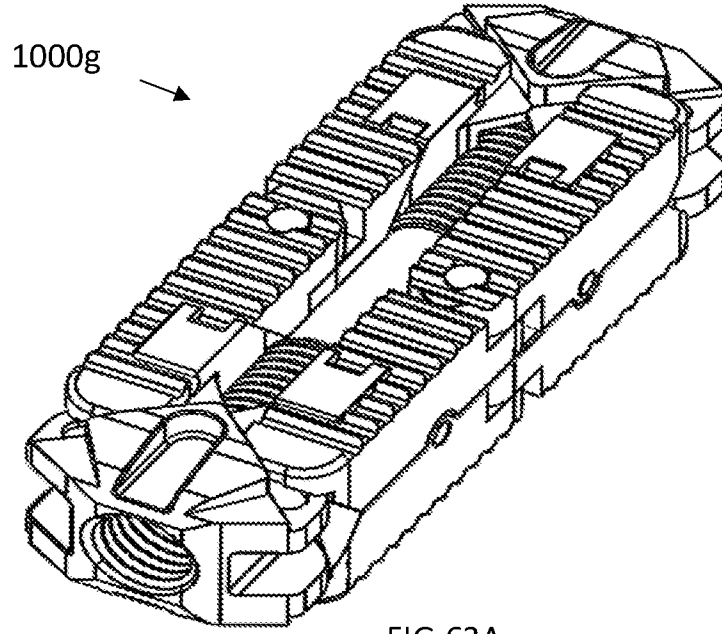
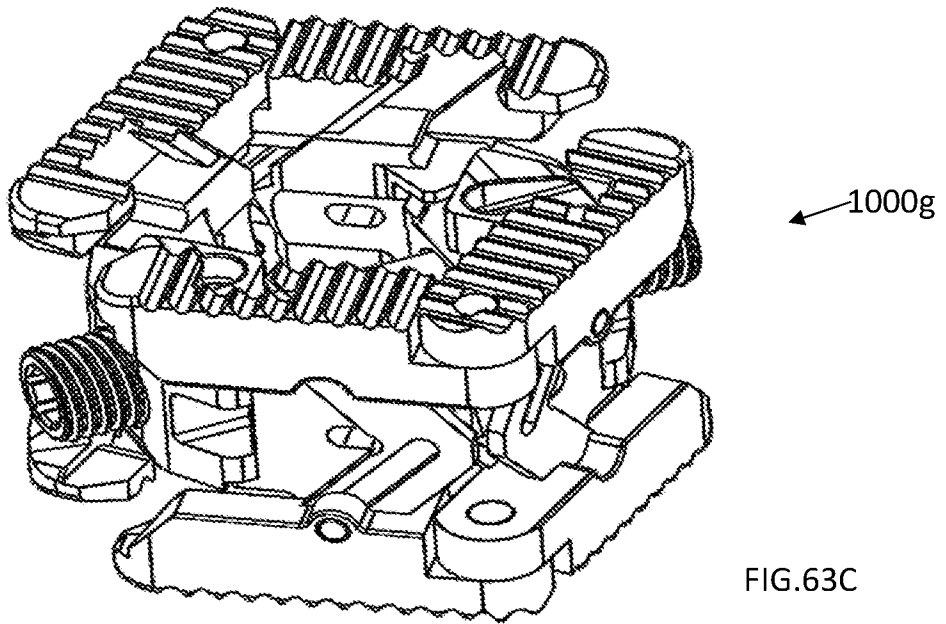

FIG. 62B





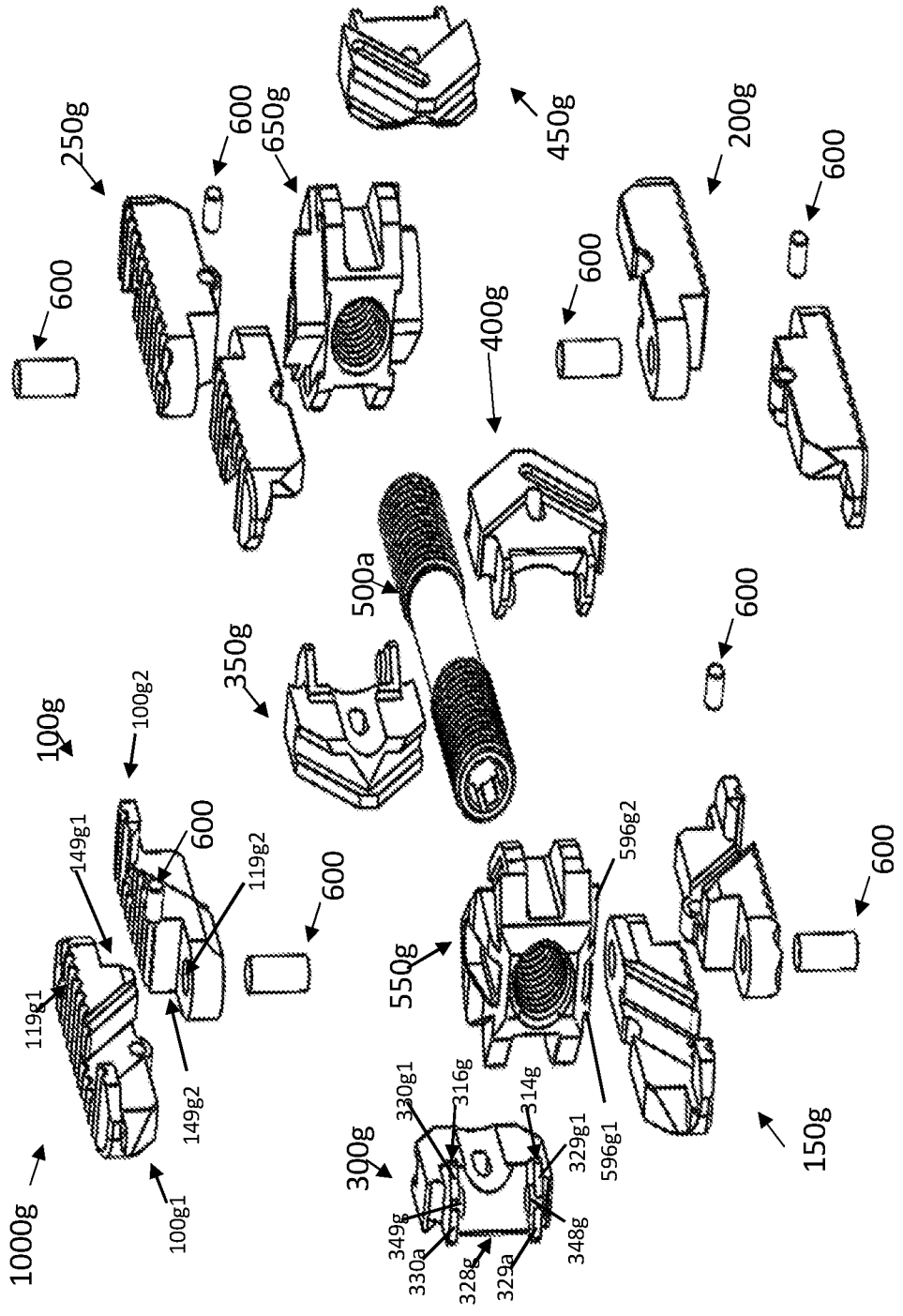

FIG.63D

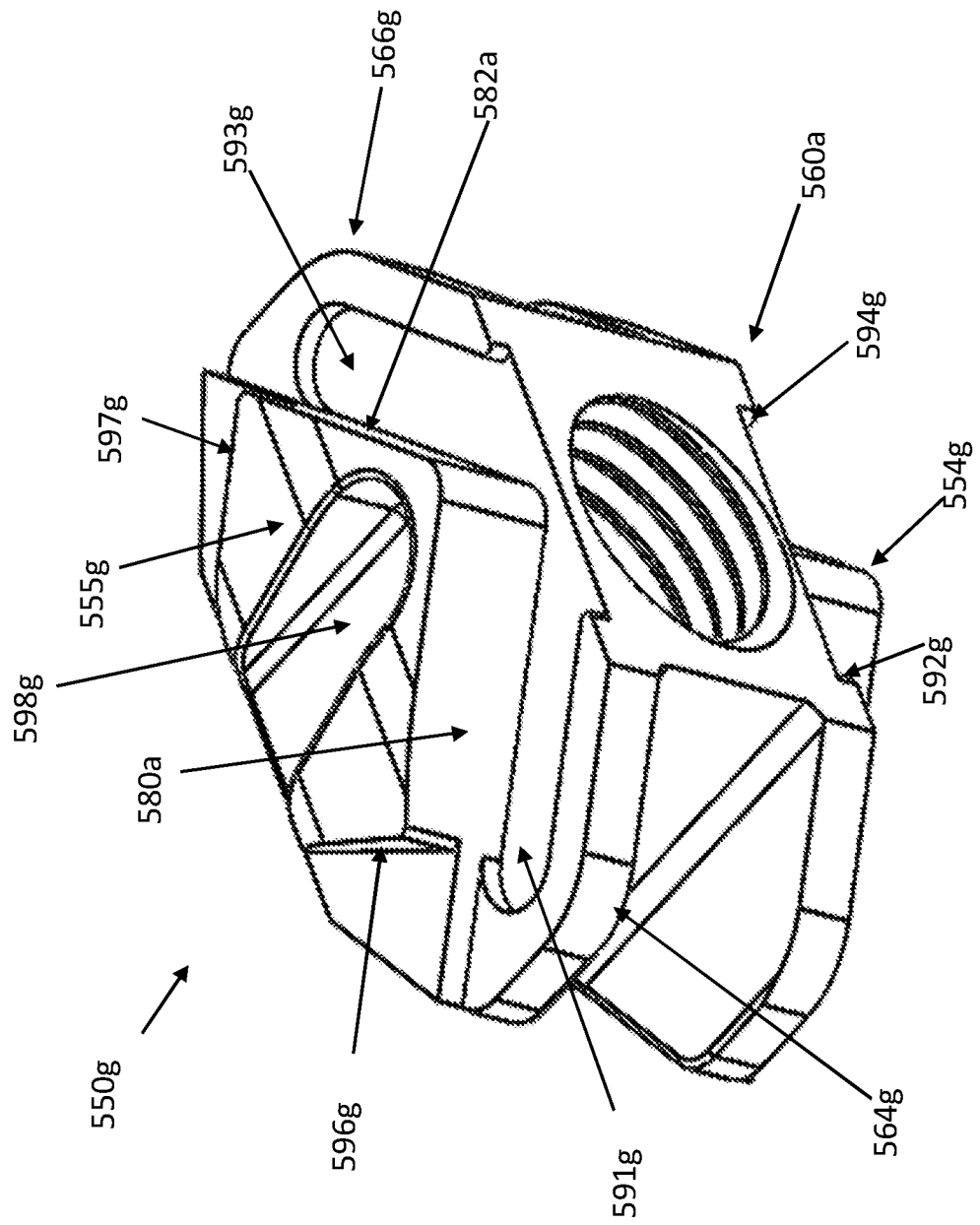

FIG.64

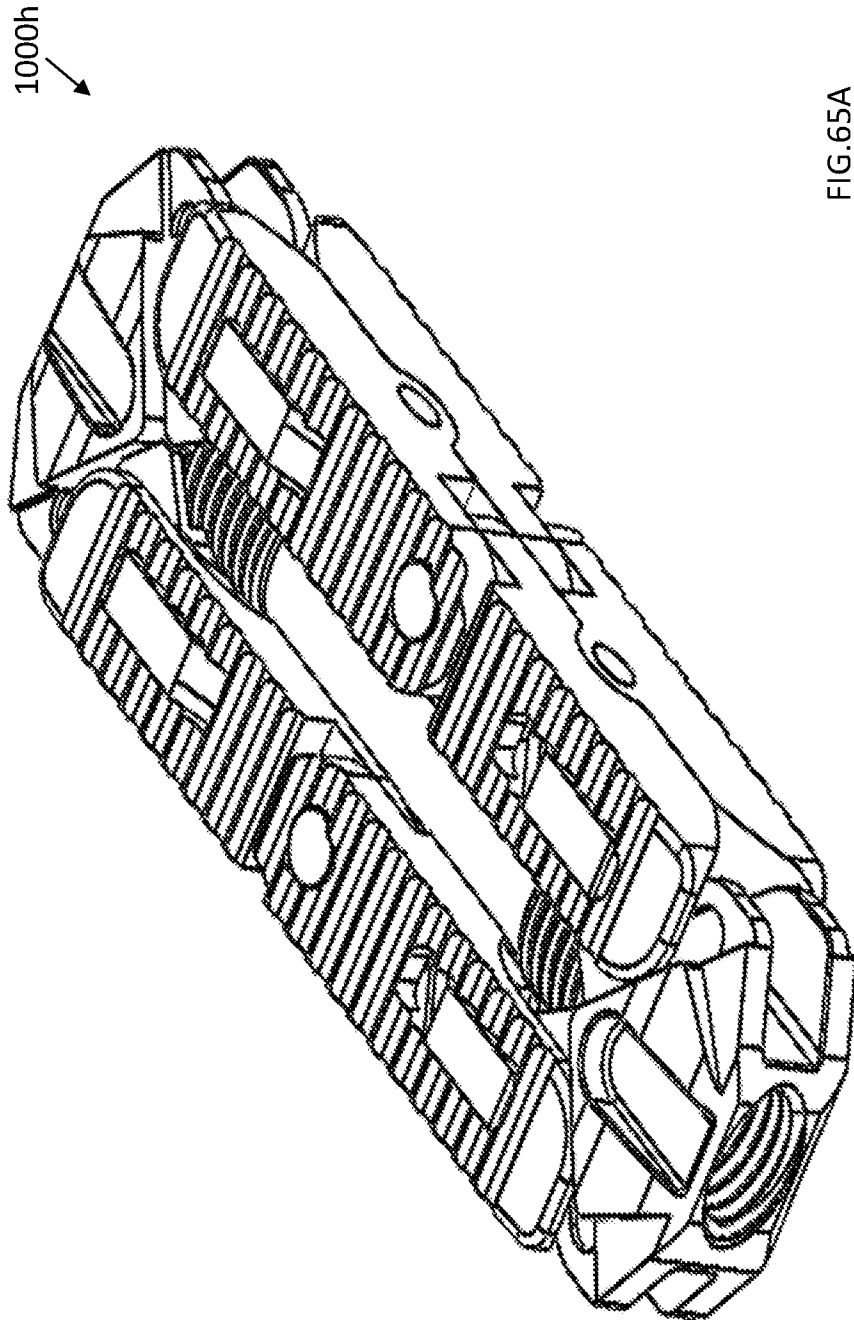

FIG. 65A

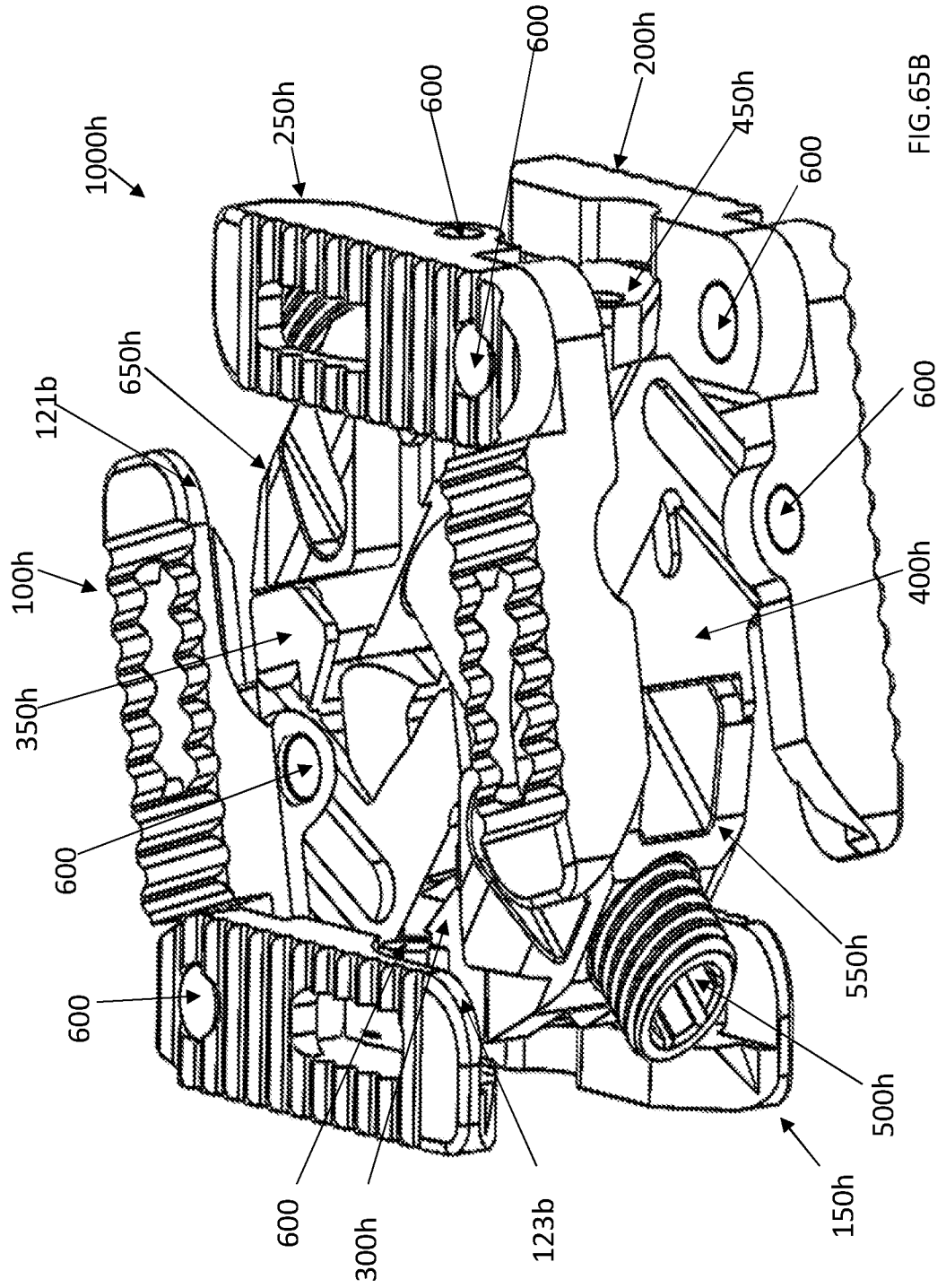

FIG.65B

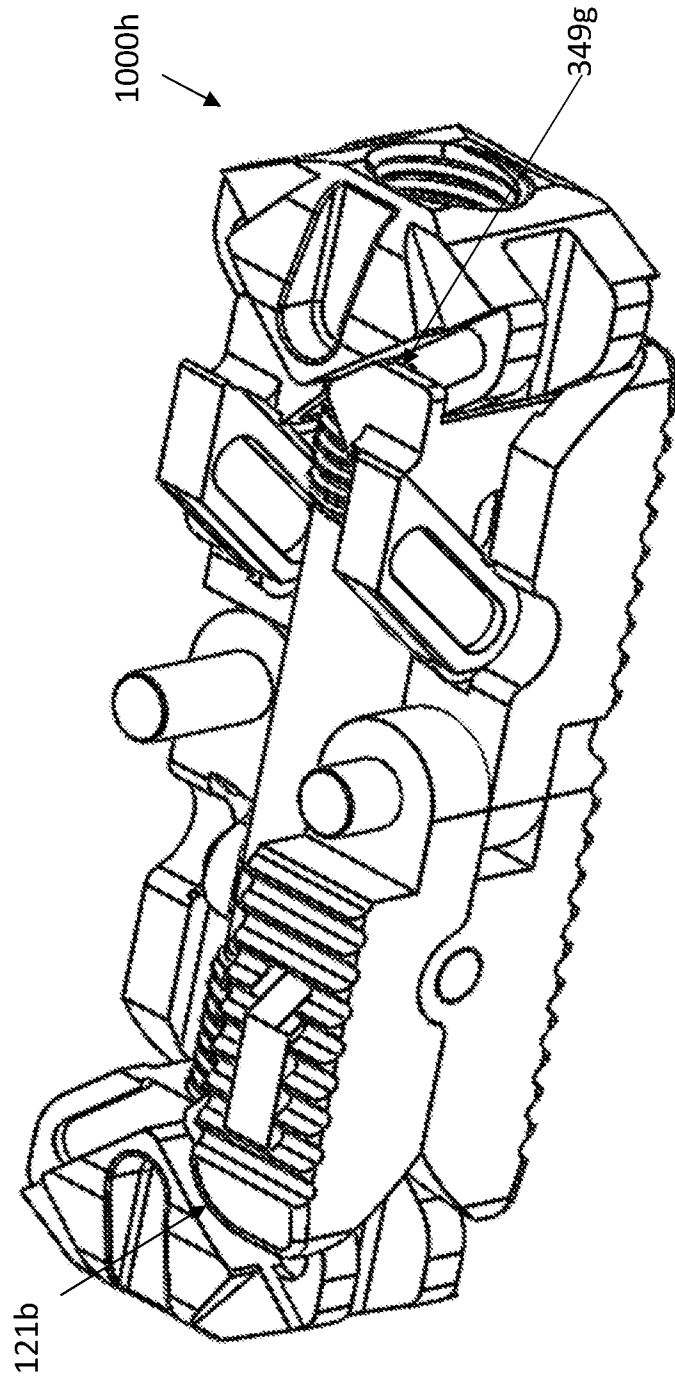

FIG.65C

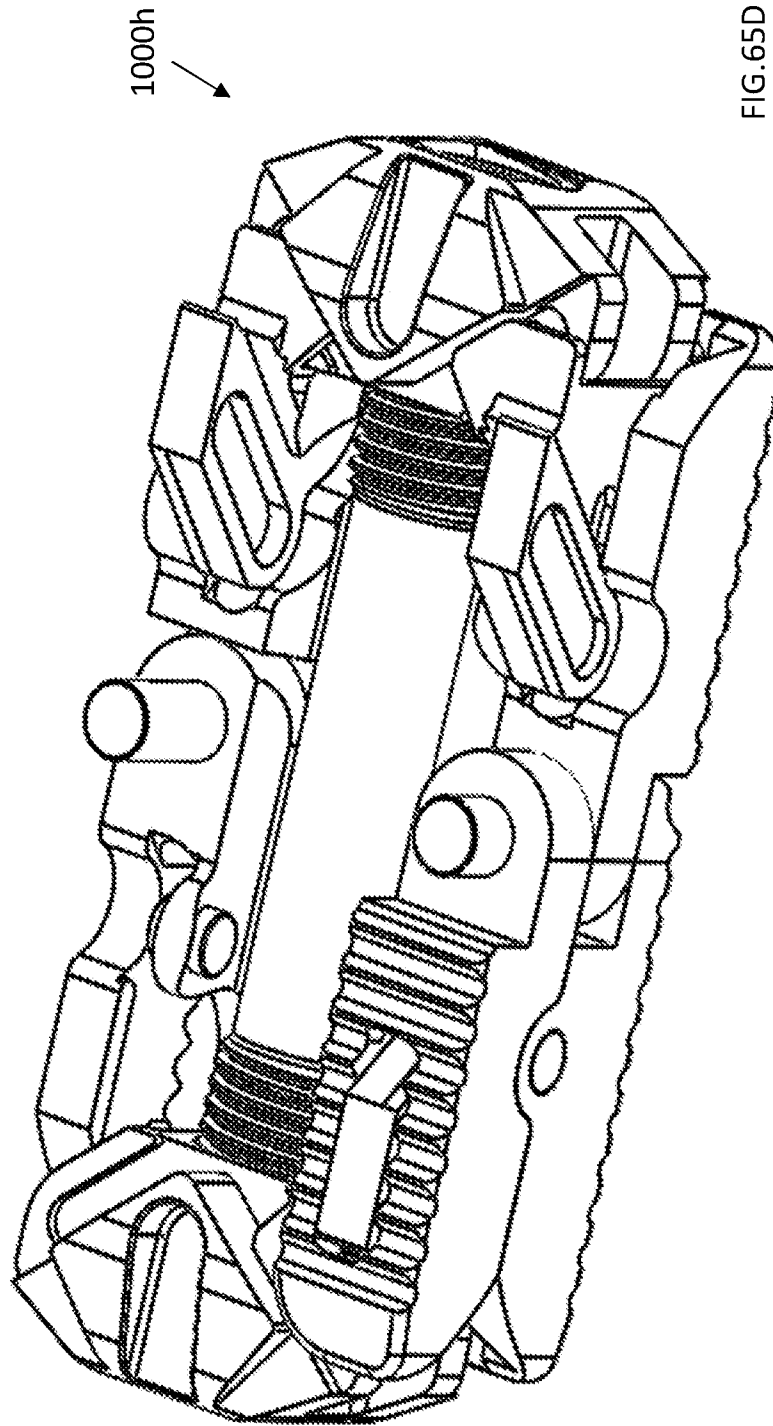

FIG. 65D

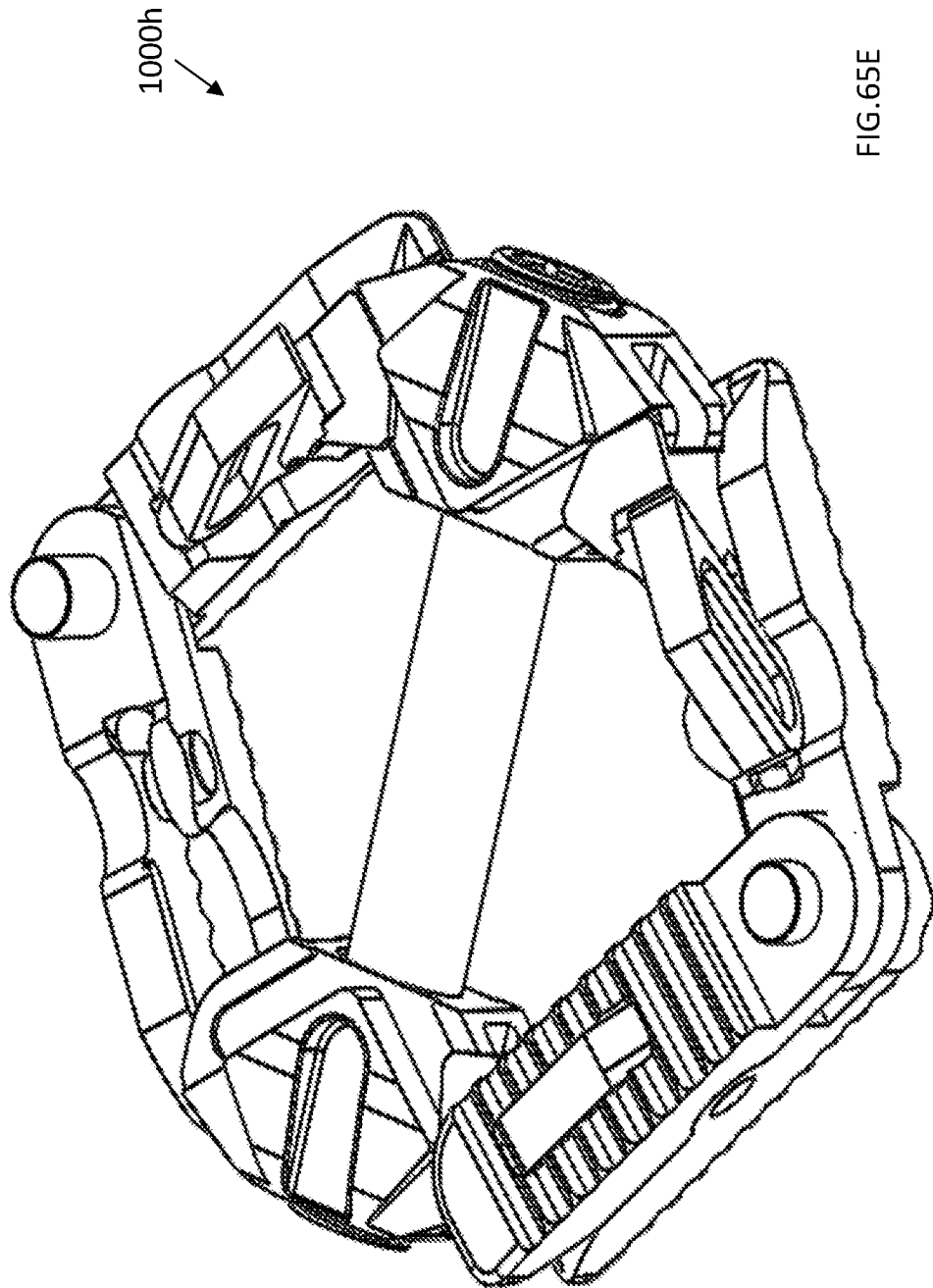

FIG. 65E

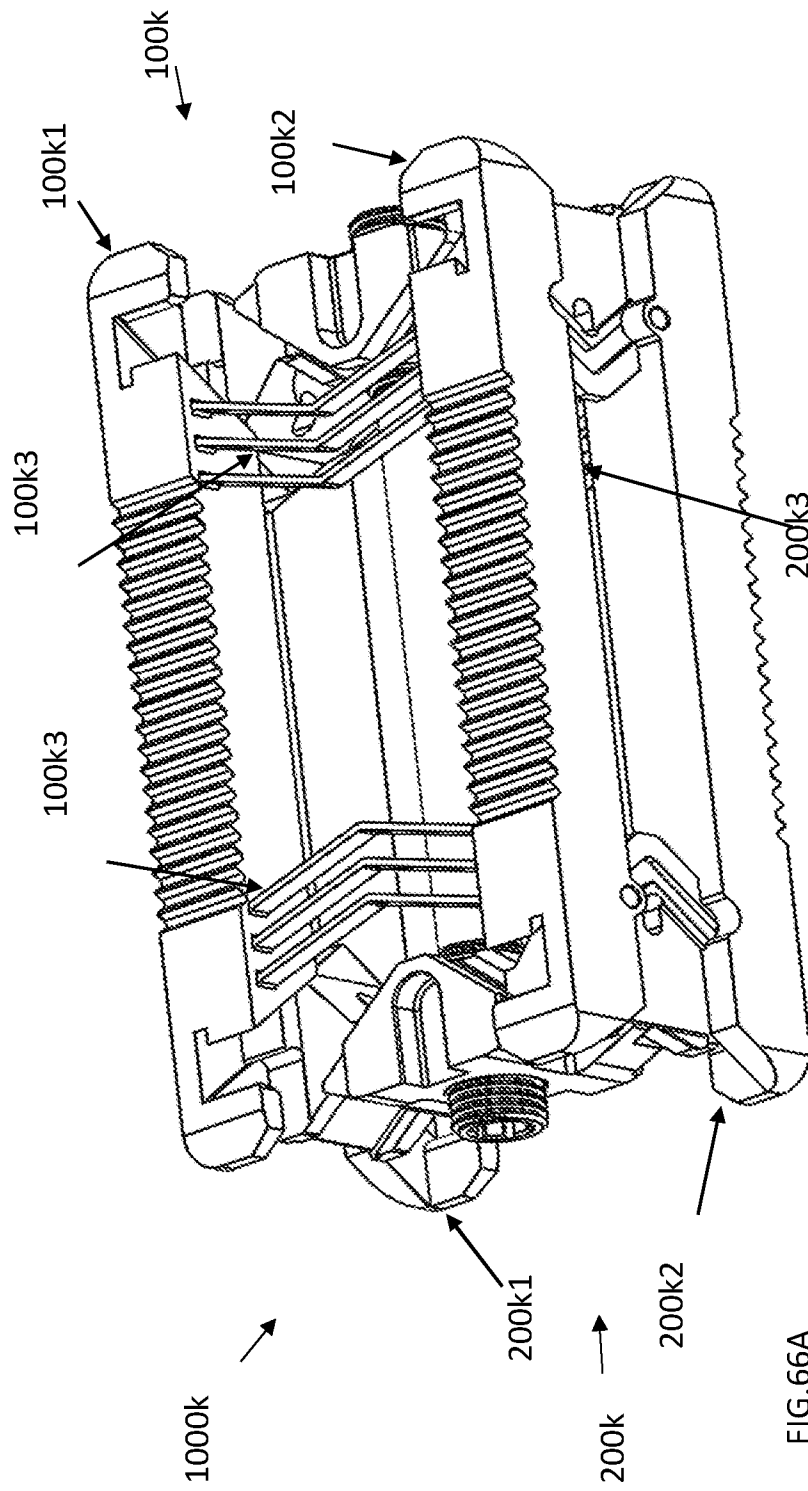
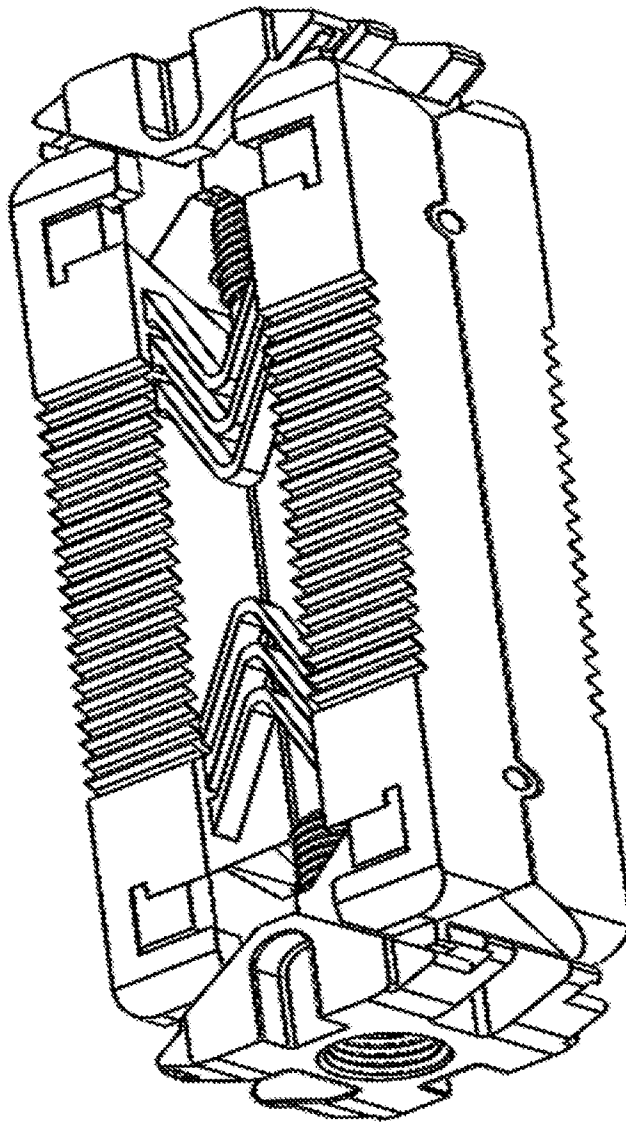

FIG. 66A

1000K

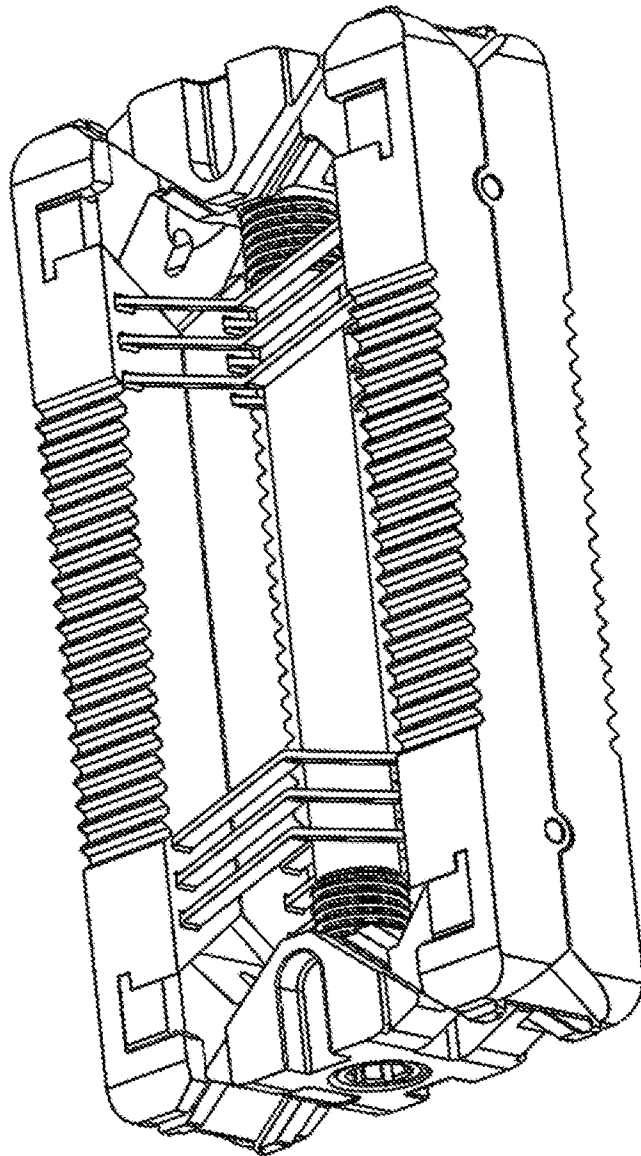

FIG. 66B



1000k
↙

FIG. 66C



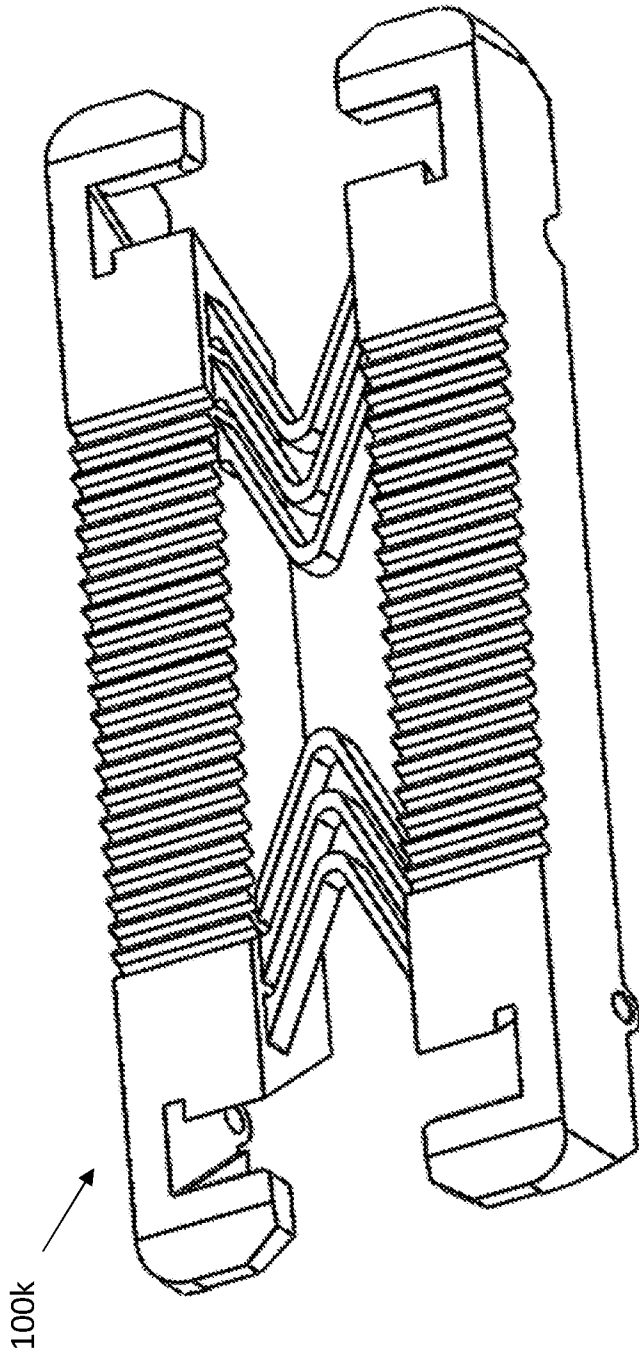

FIG.66D

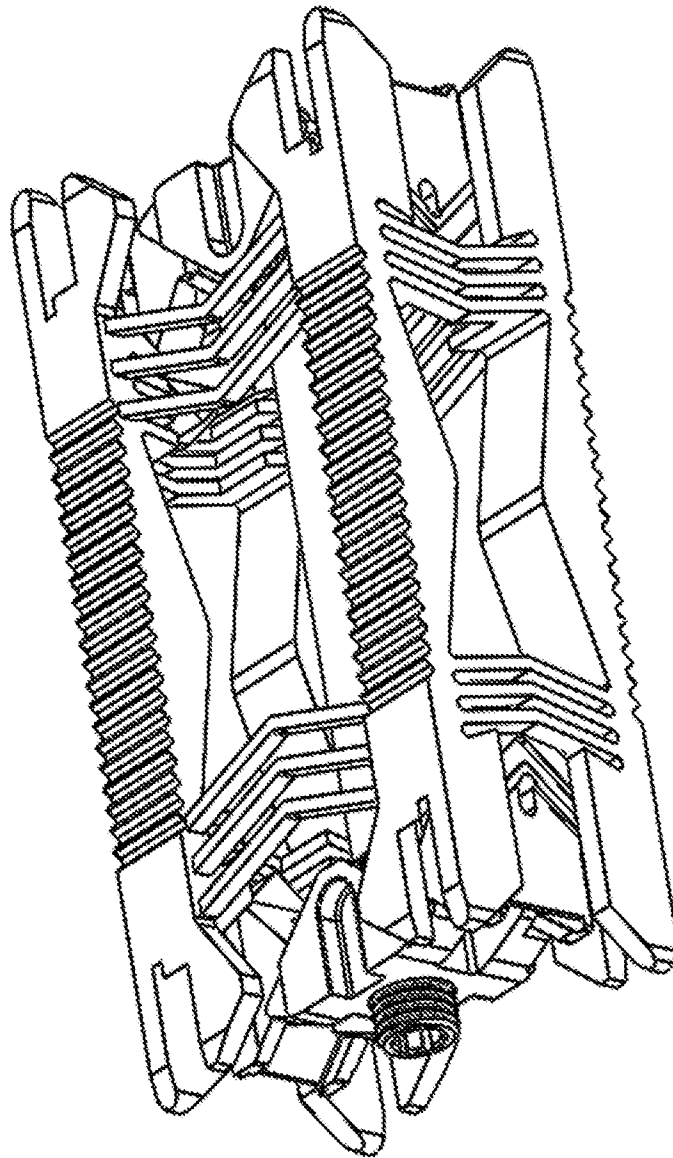

FIG.67A

1000m

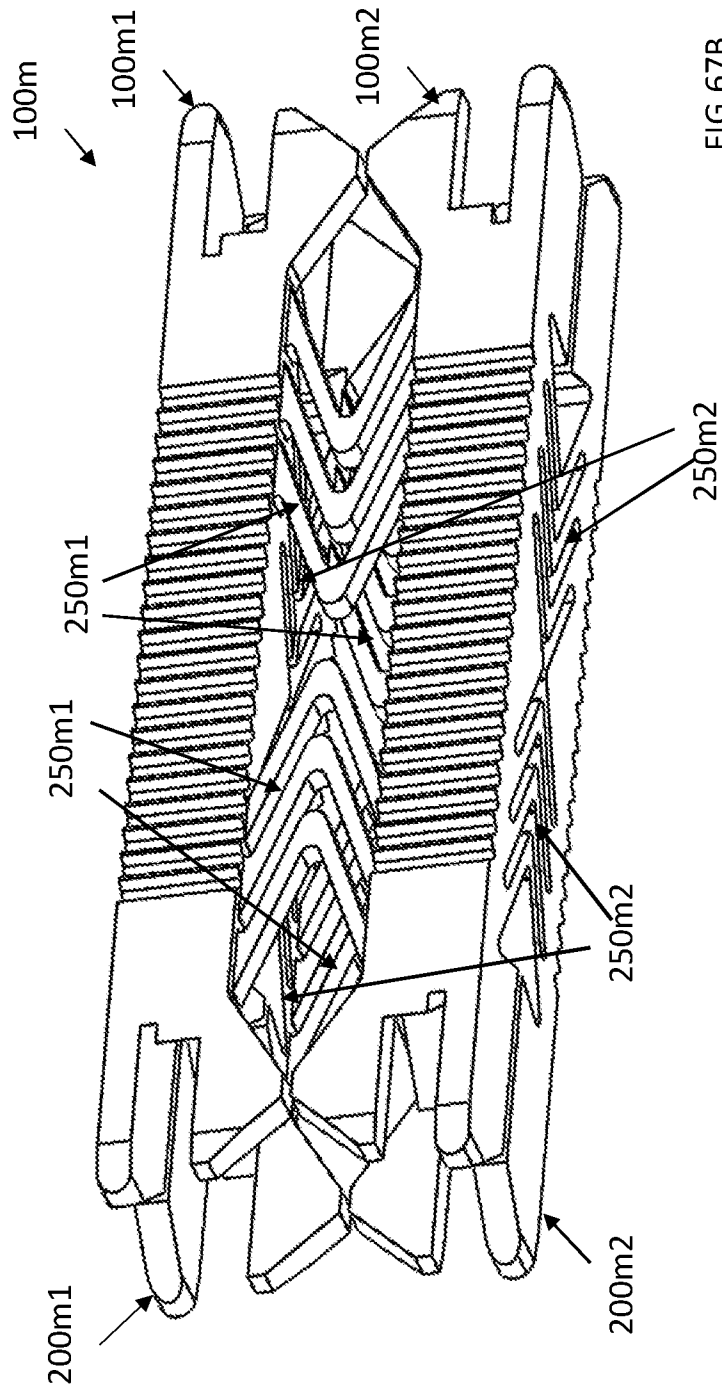
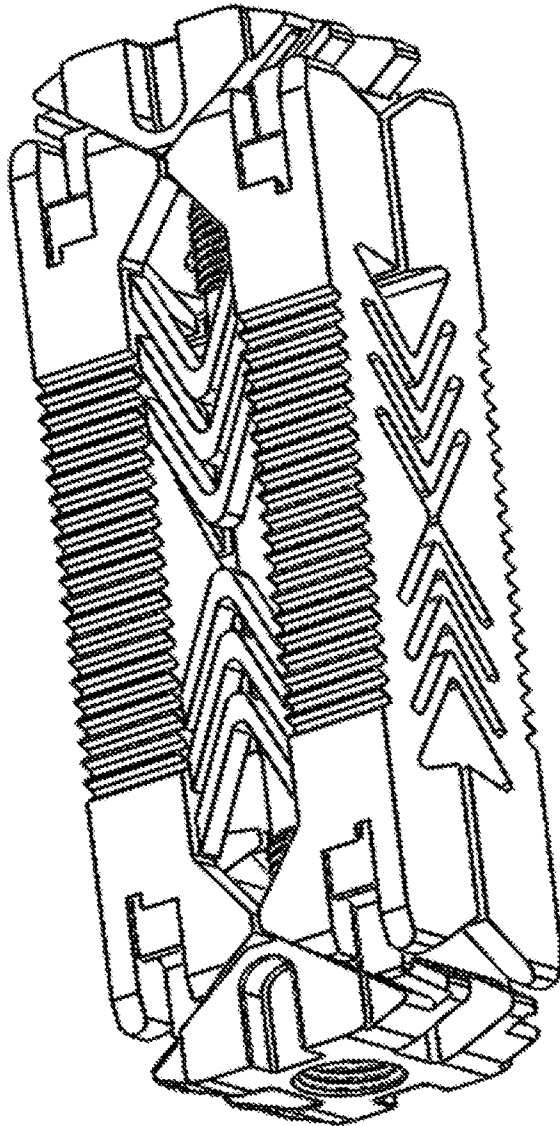

FIG.67B

1000m
↙

FIG.67C



1000m



FIG. 67D

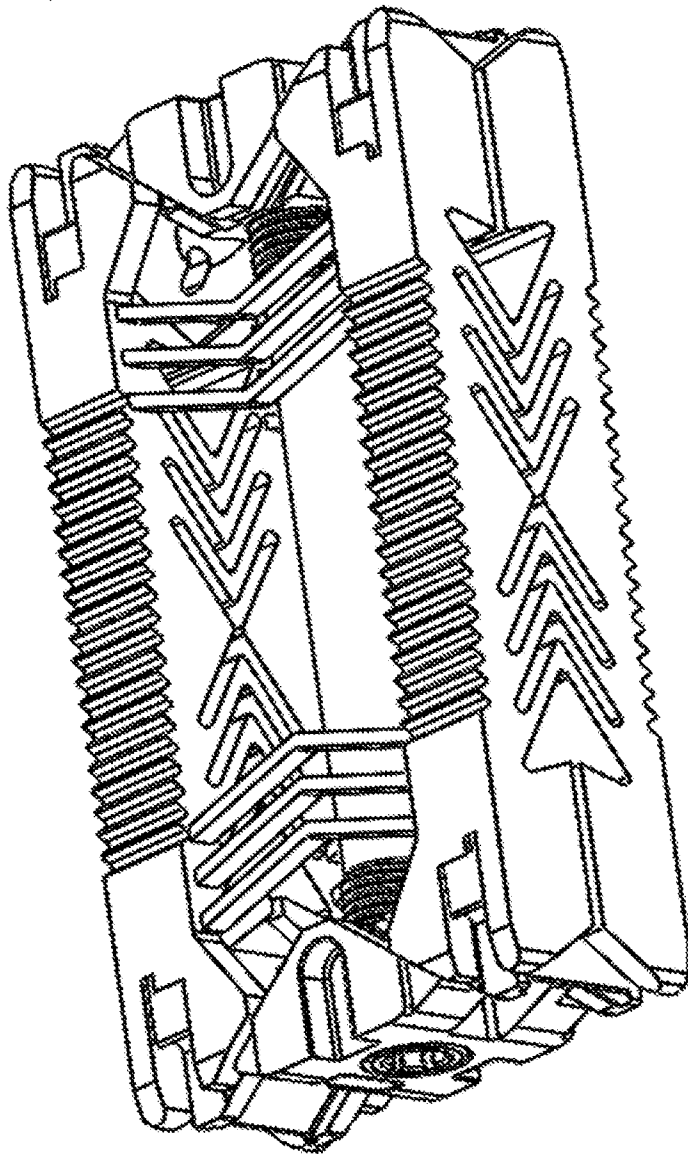

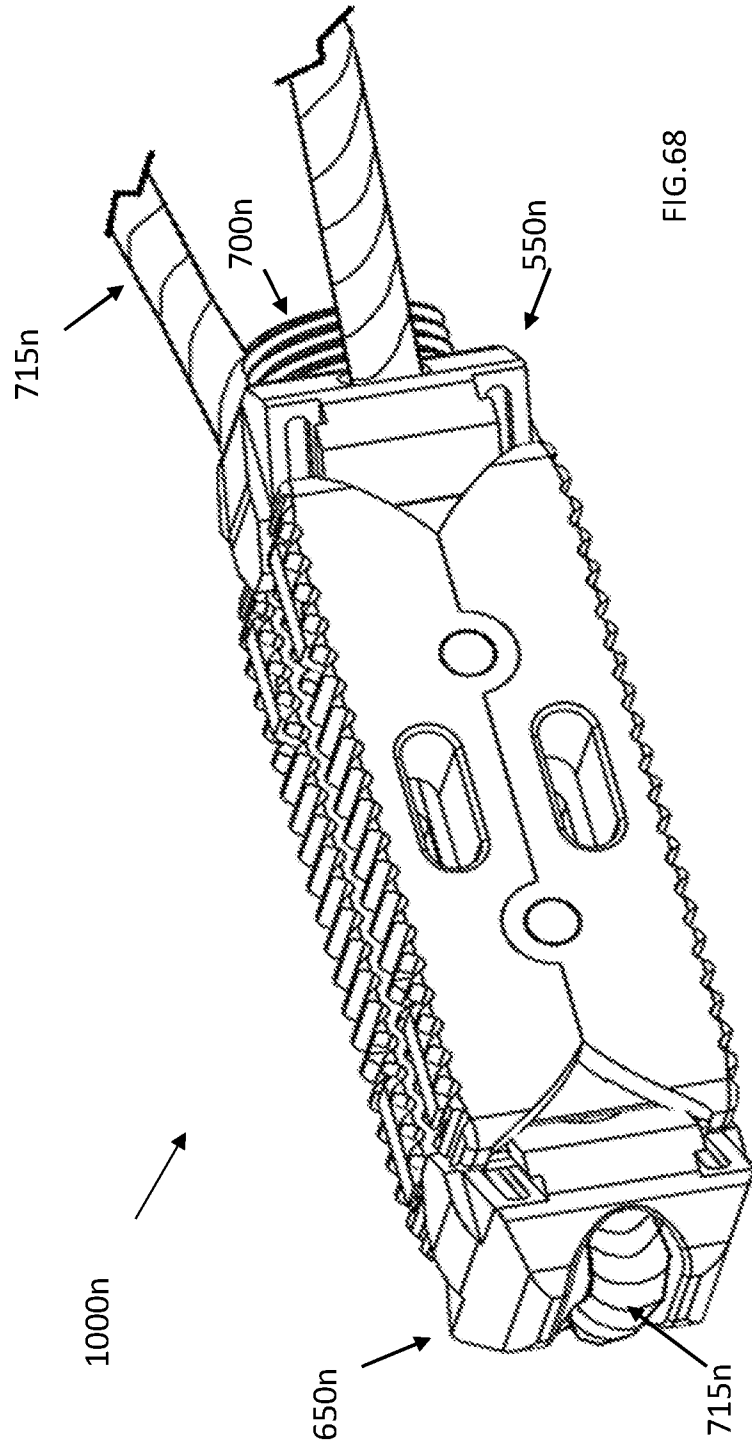

FIG. 68

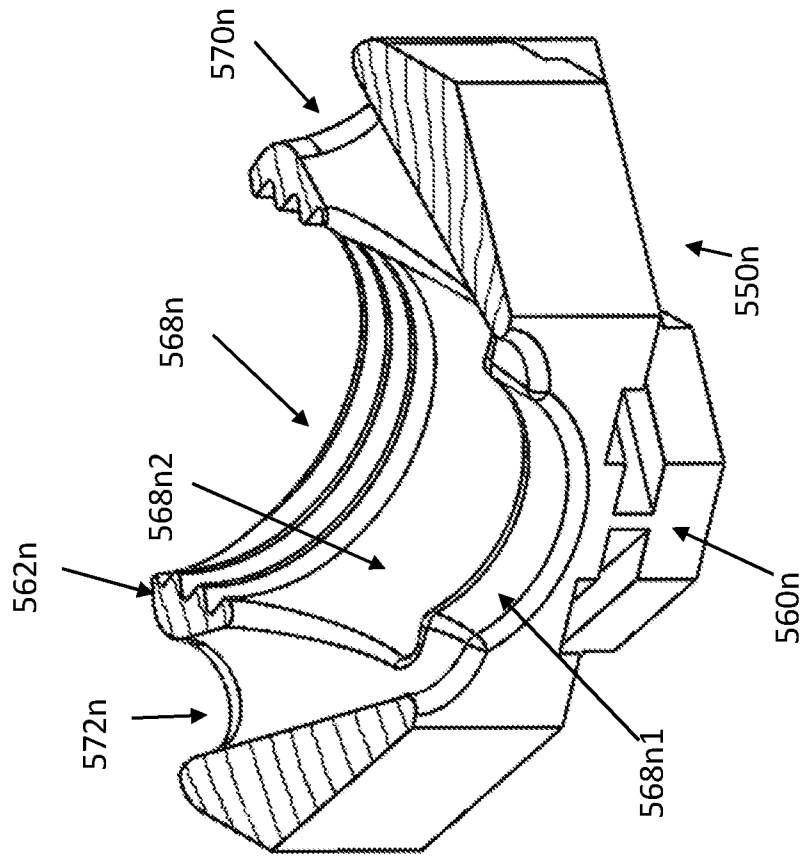

FIG. 69B

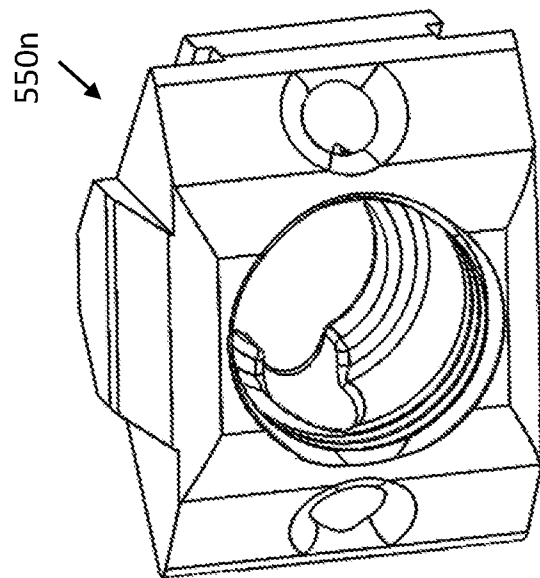

FIG. 69A

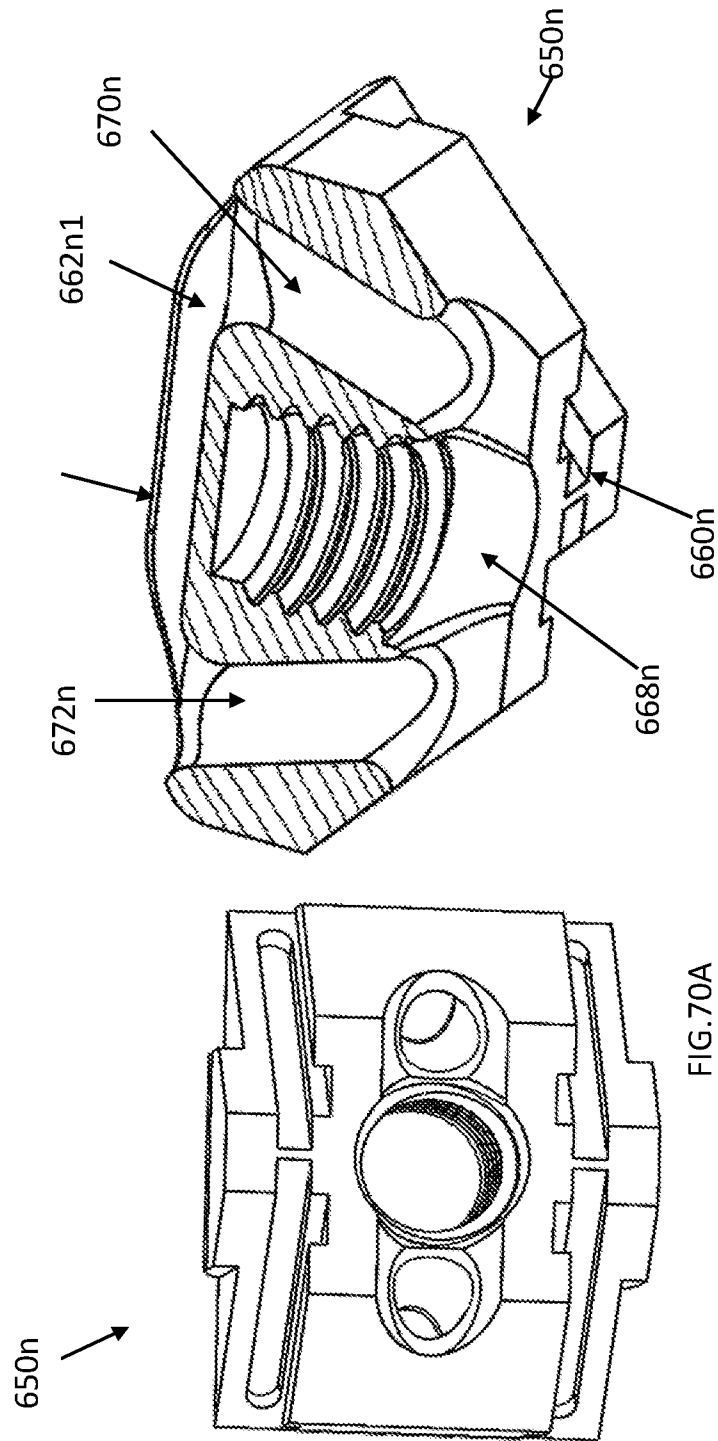

FIG. 70B

FIG. 70A

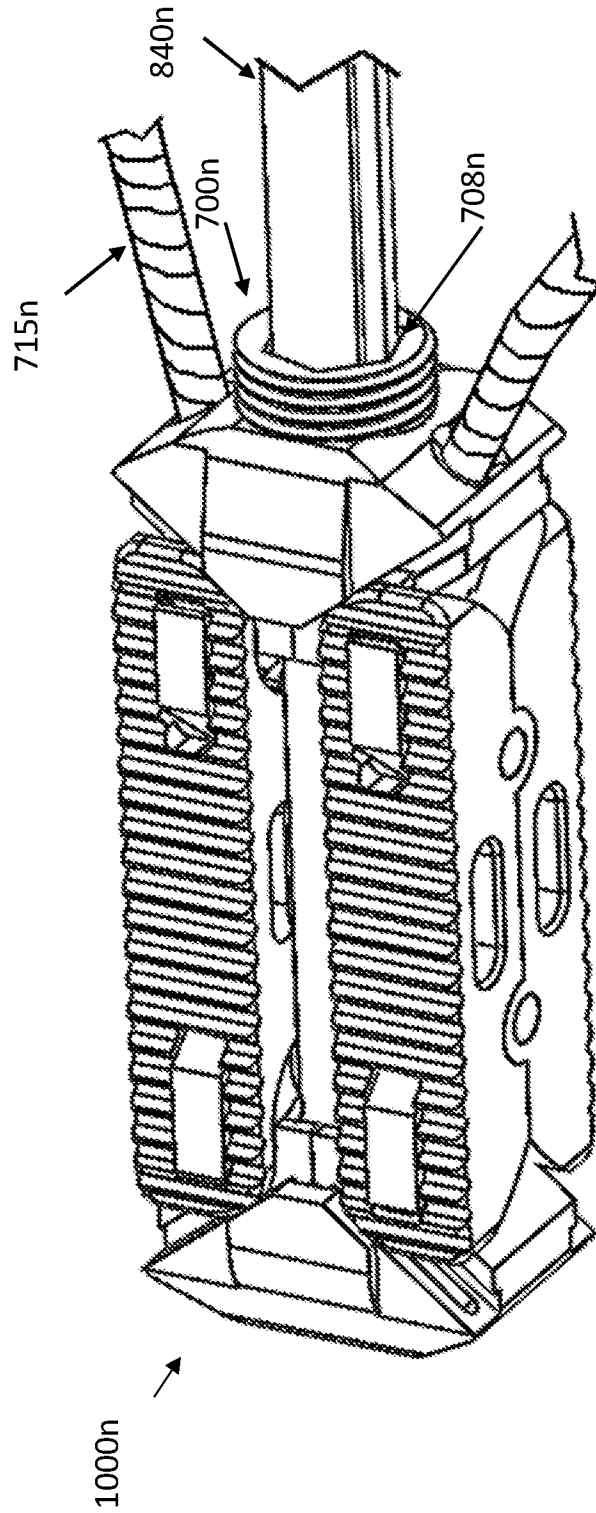
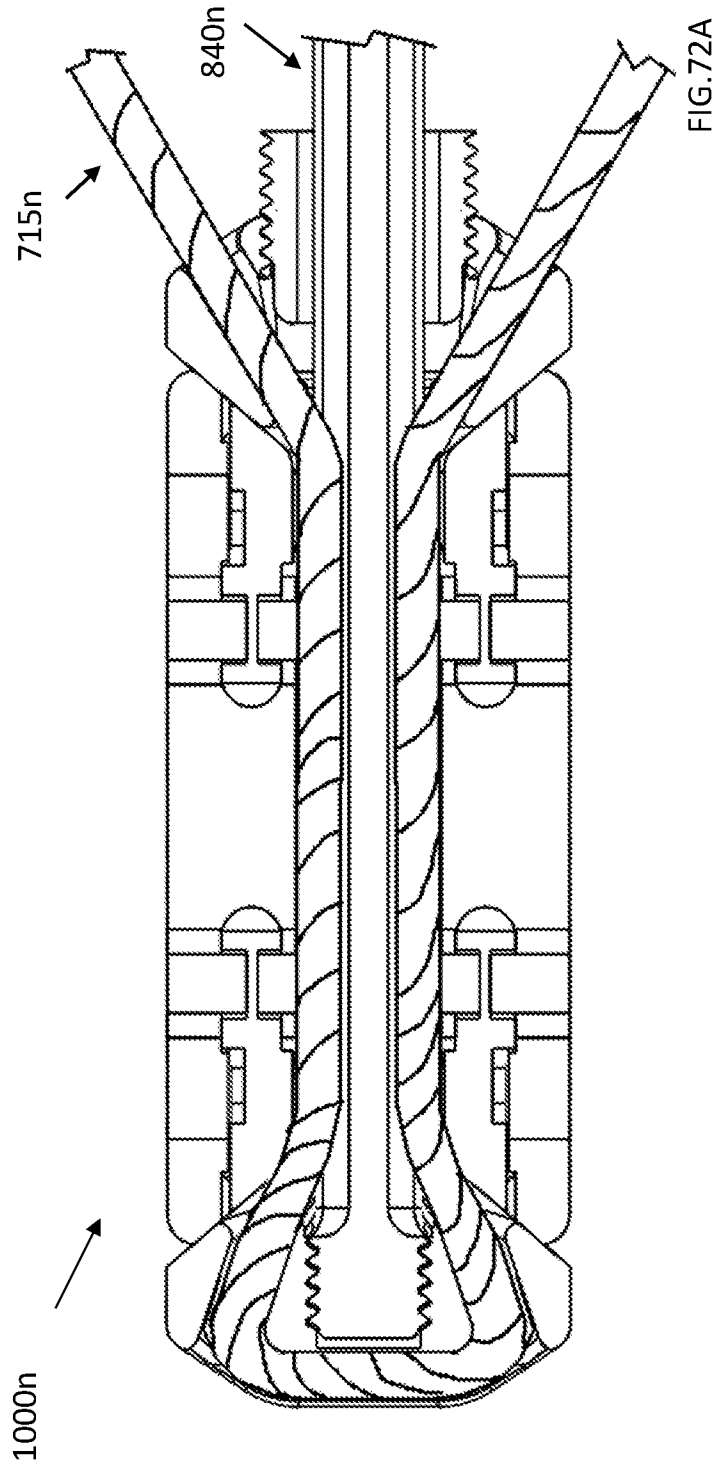

FIG.71



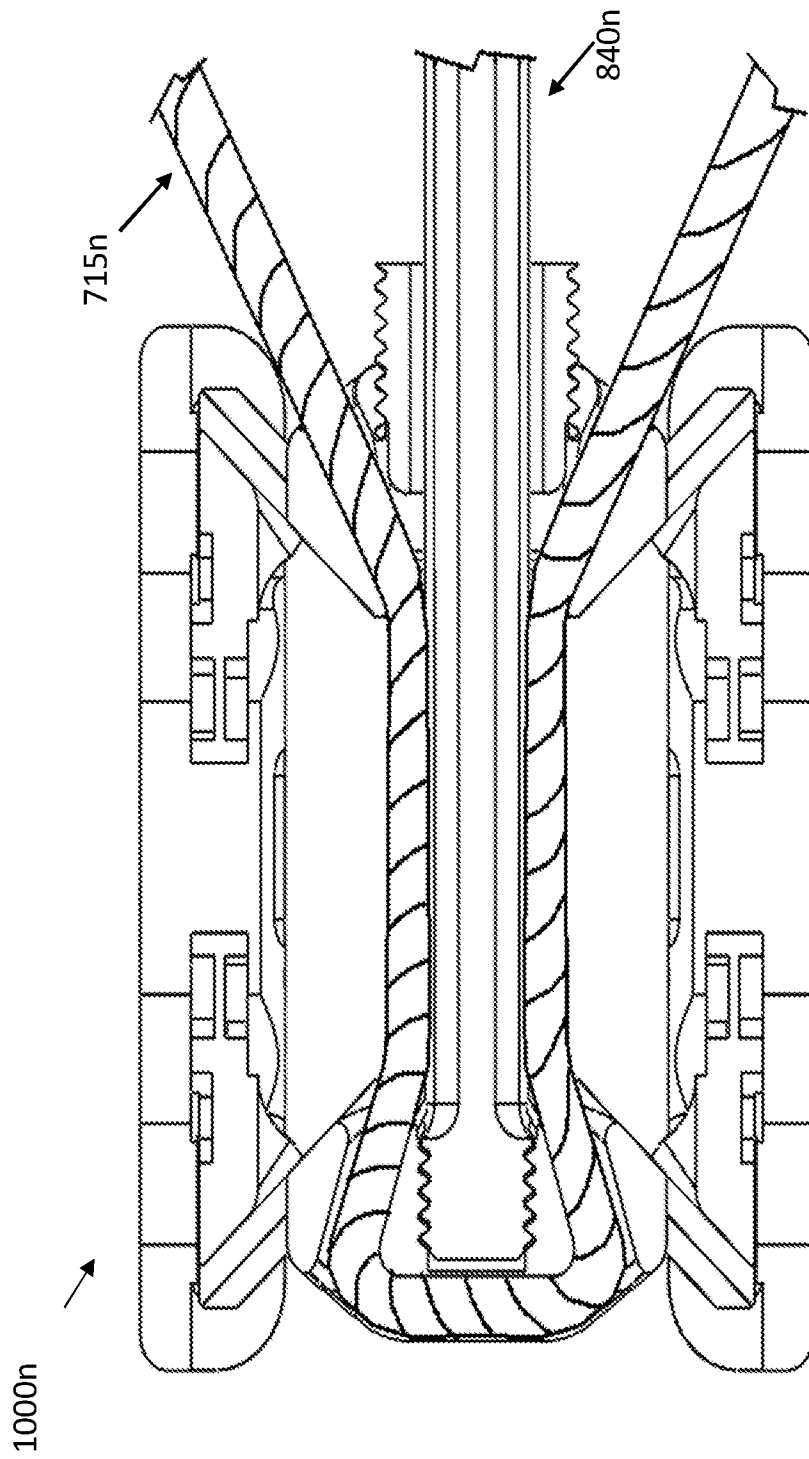

FIG. 72B

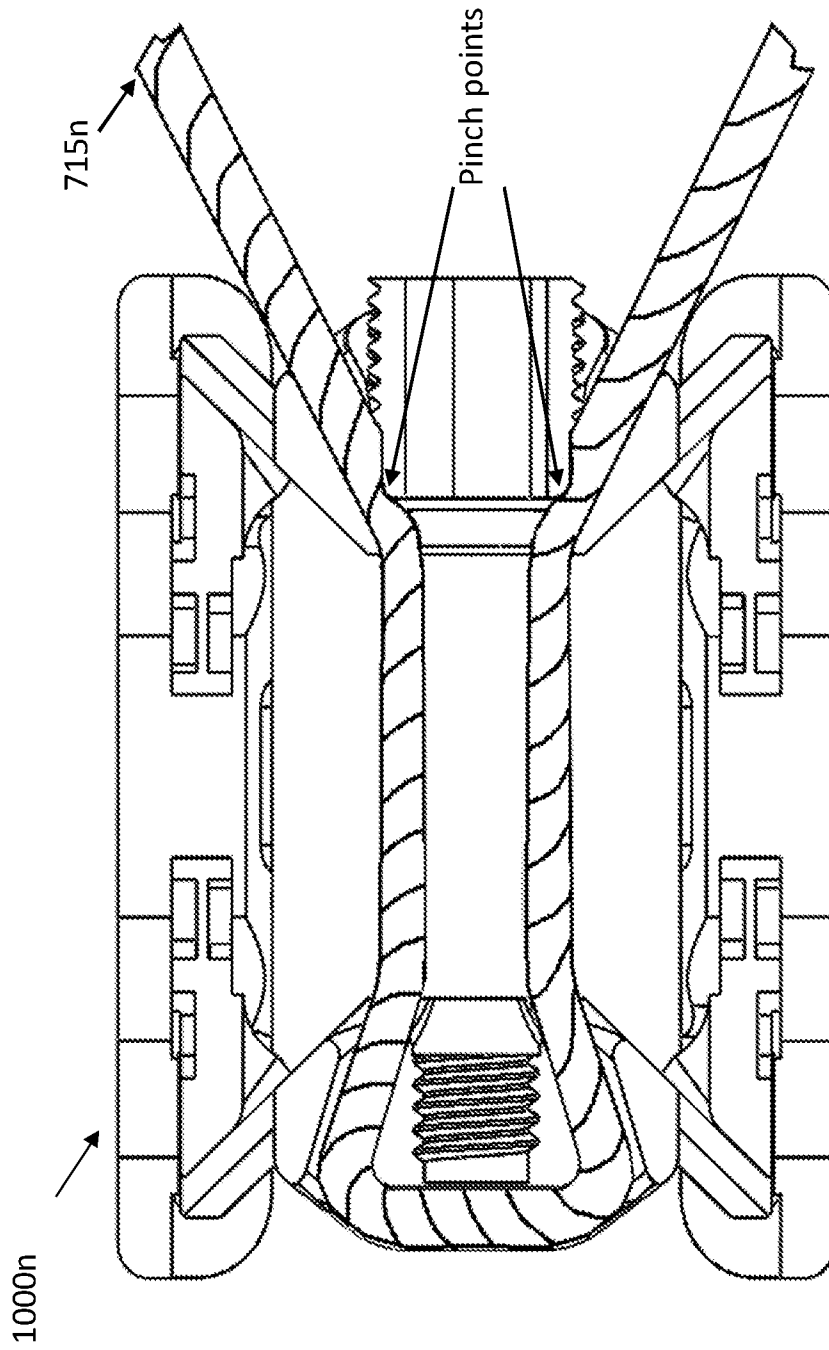

FIG.72C

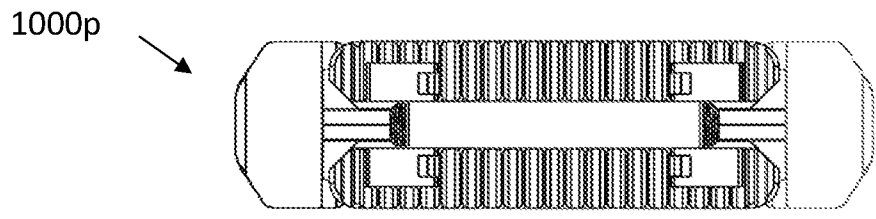

FIG. 73A

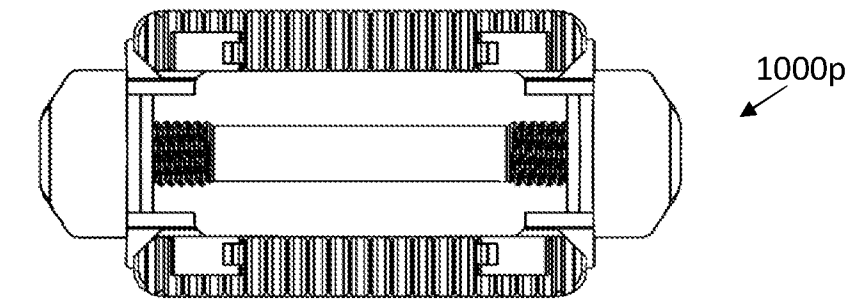

FIG. 73B

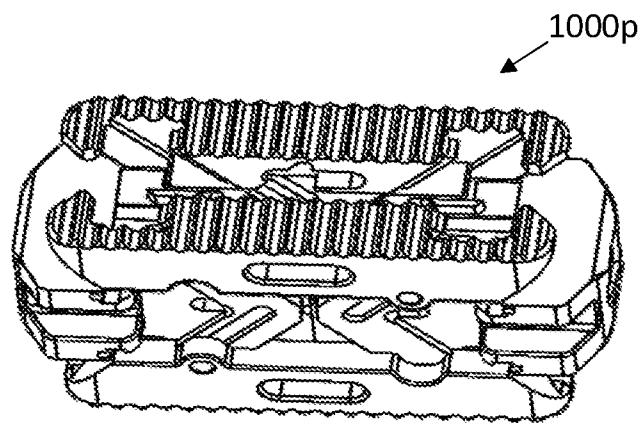

FIG. 73C

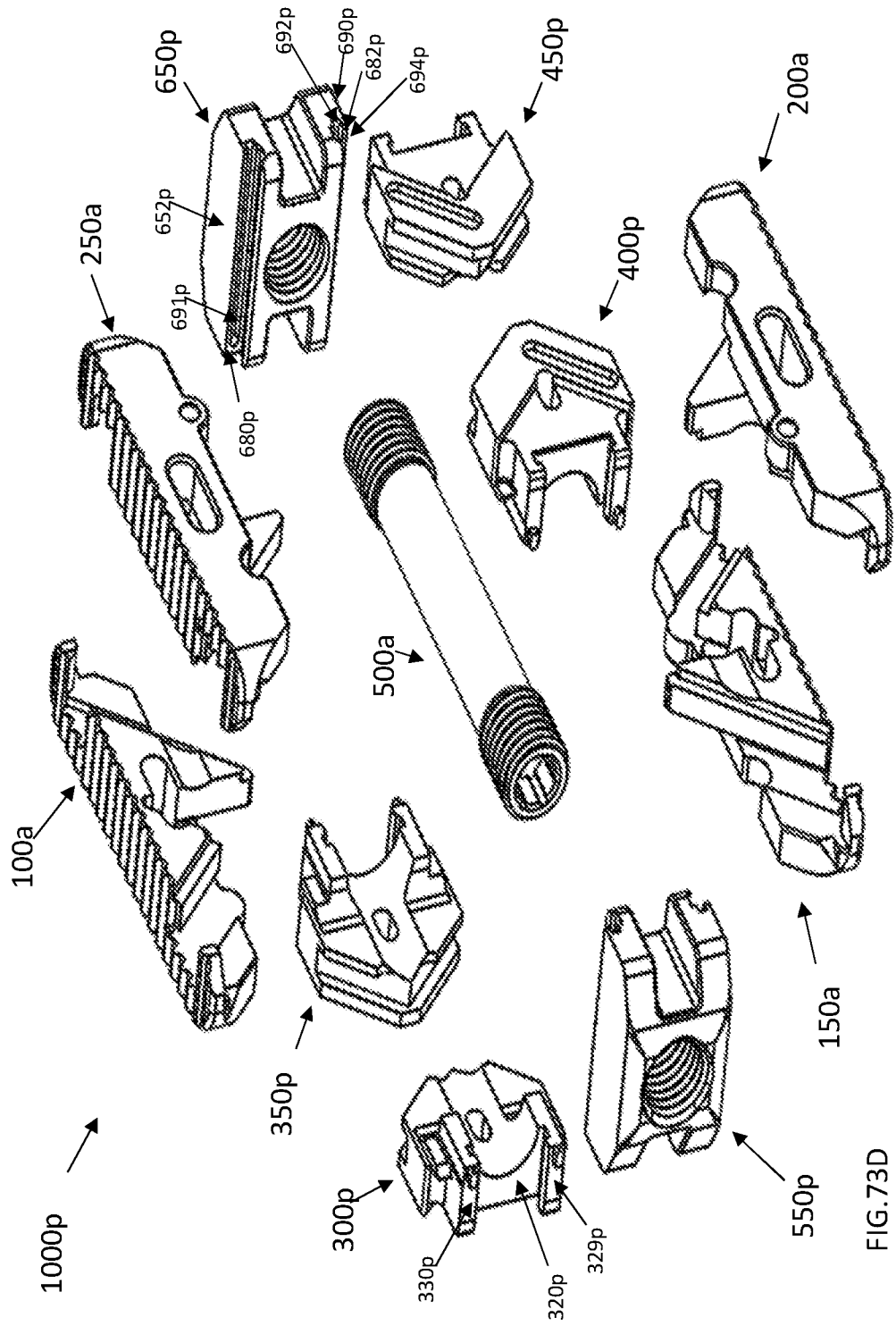
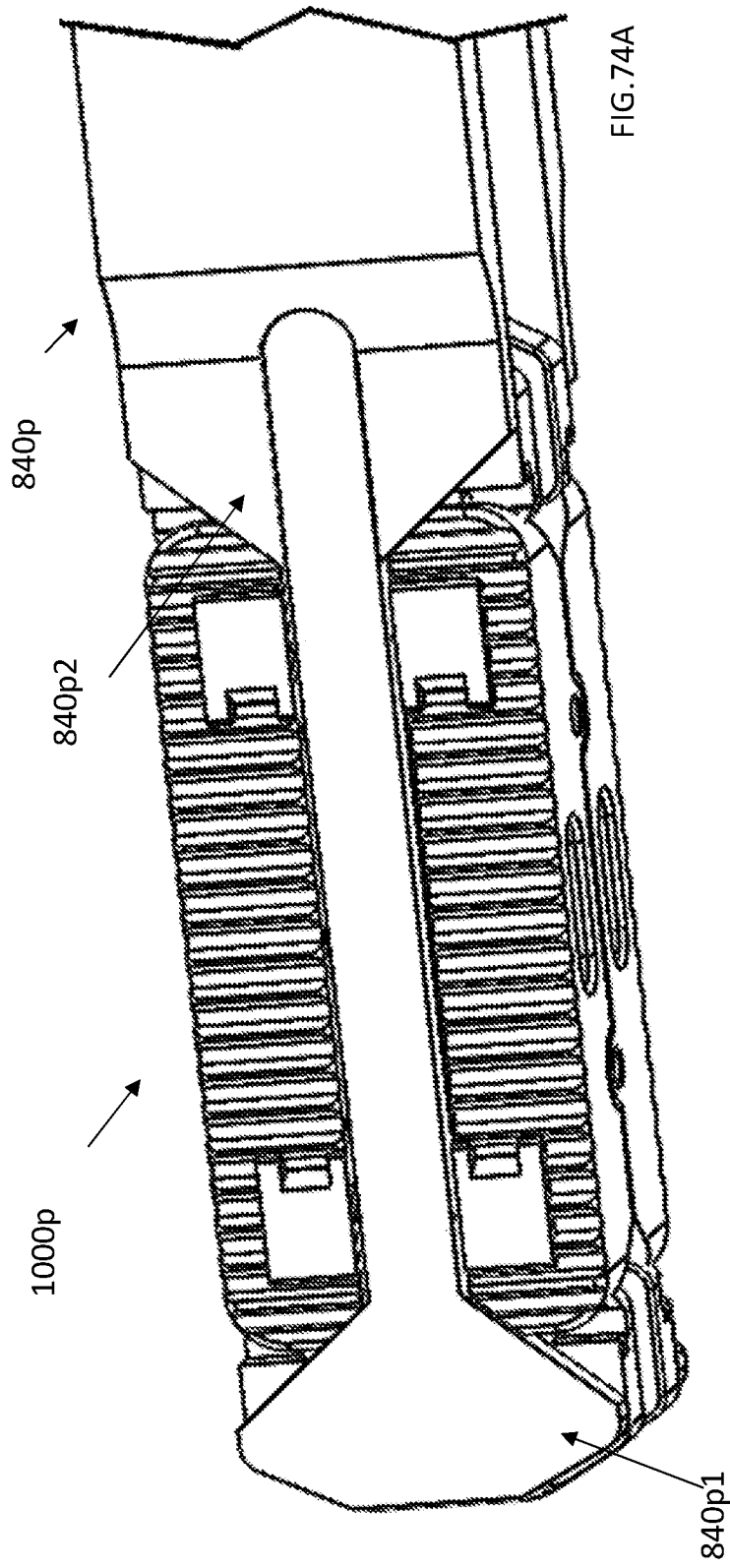

FIG.73D



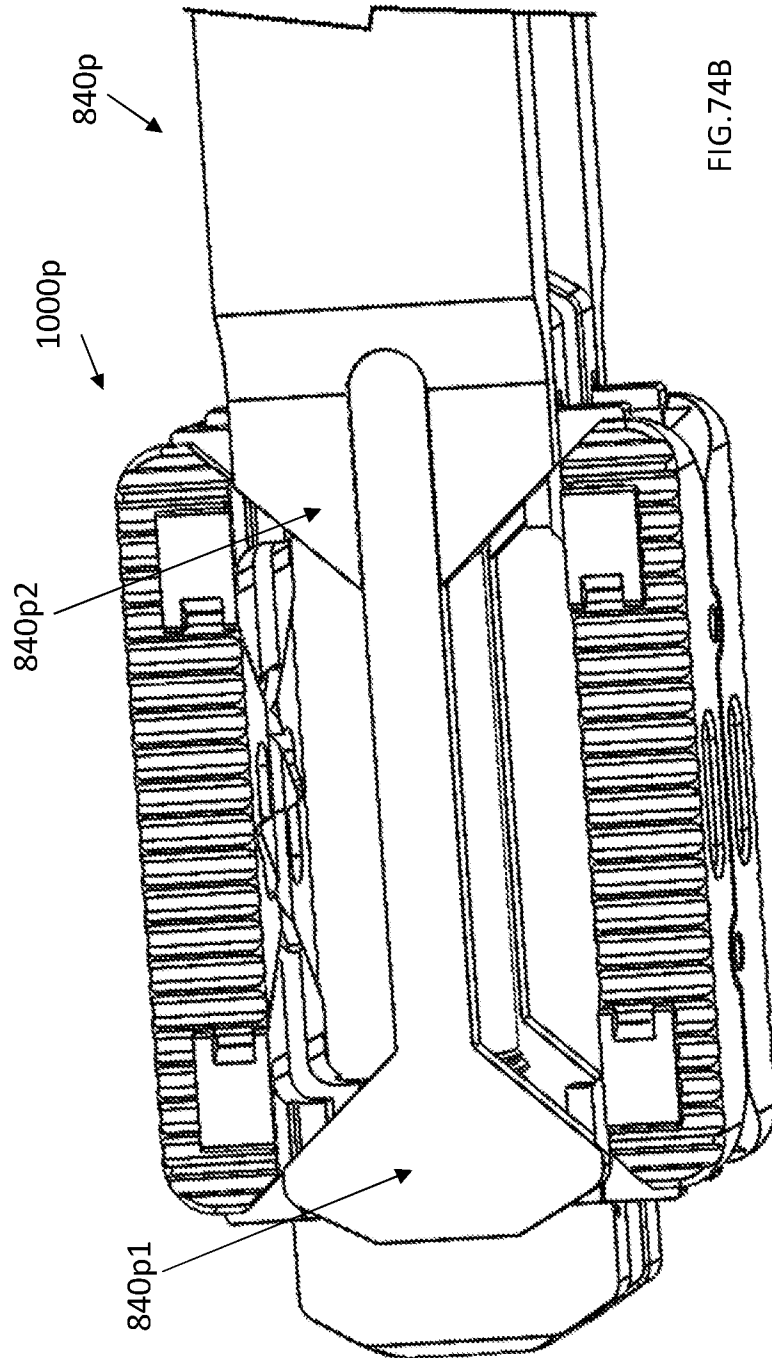
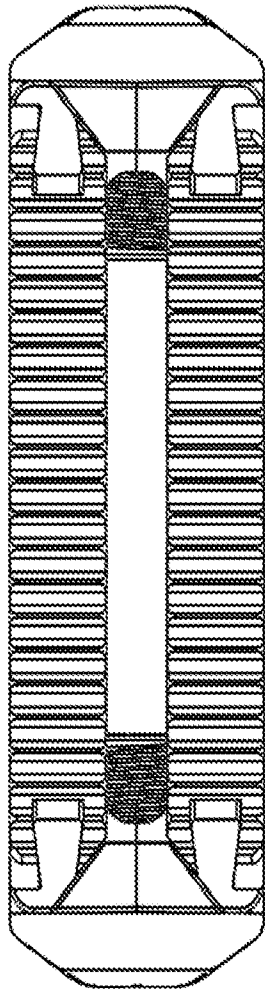
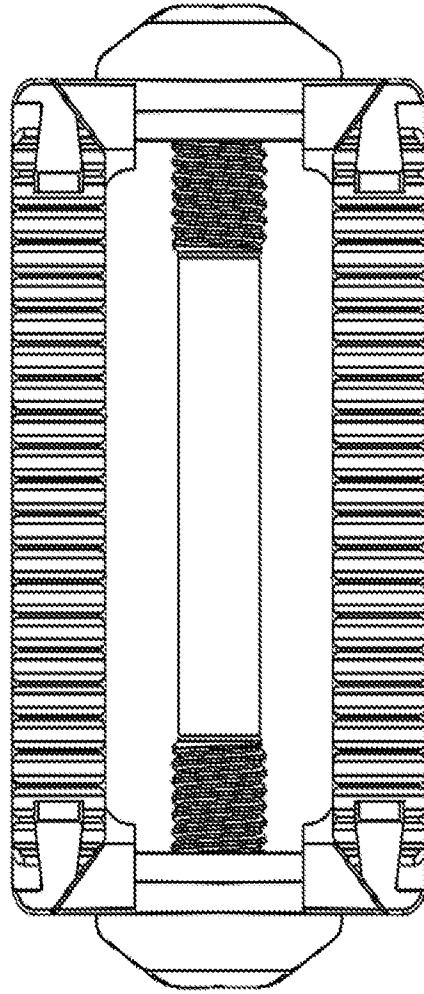

FIG. 74B



1000r
↗

FIG. 75A



1000r
↗

FIG. 75B

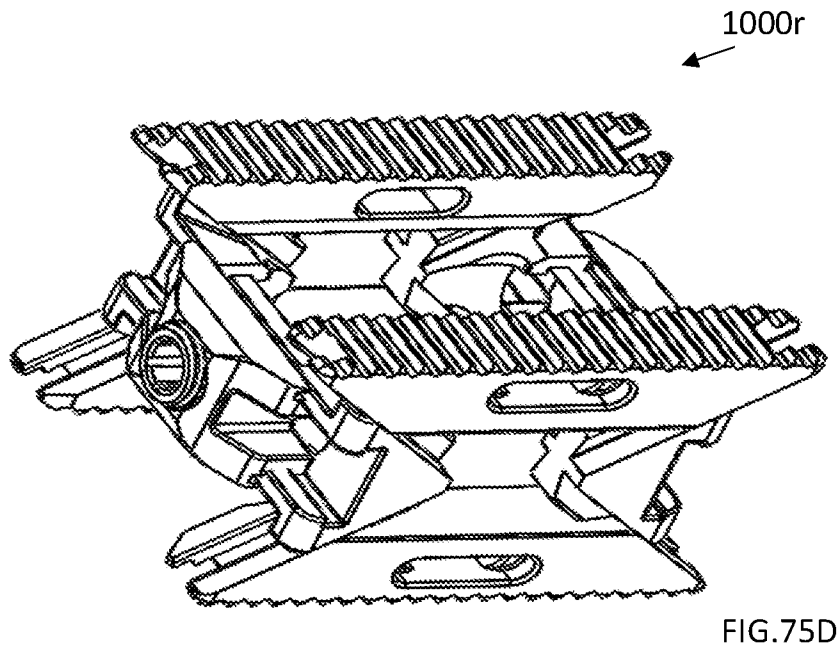
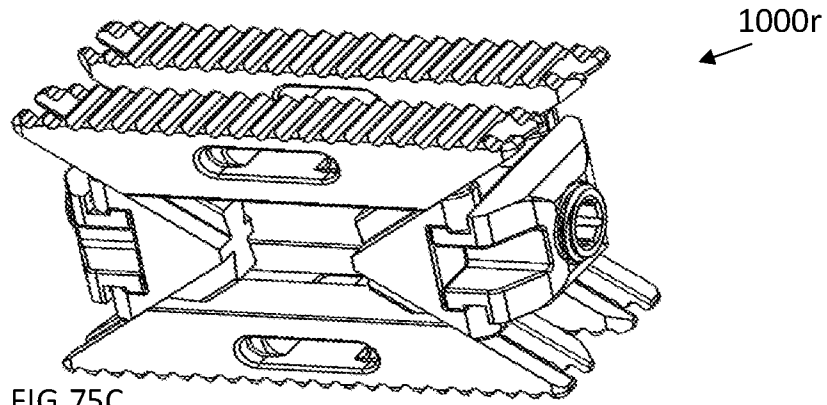

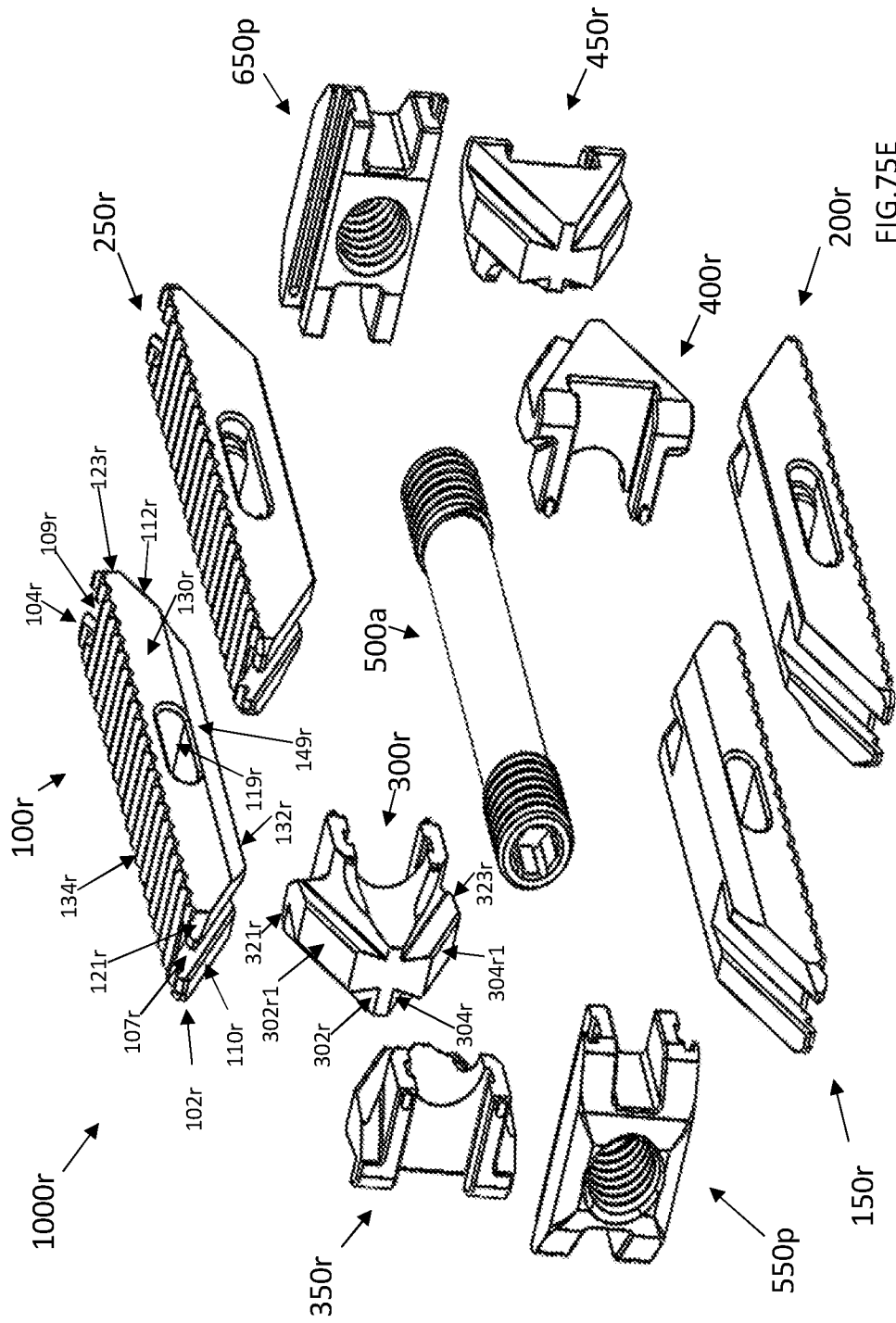
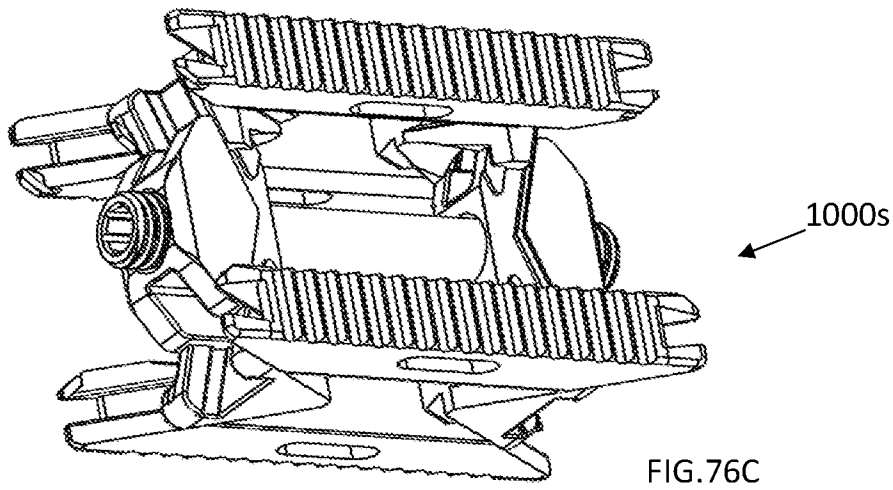
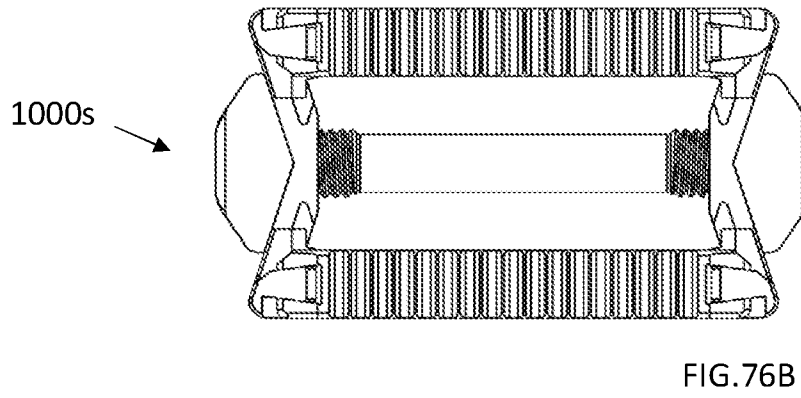
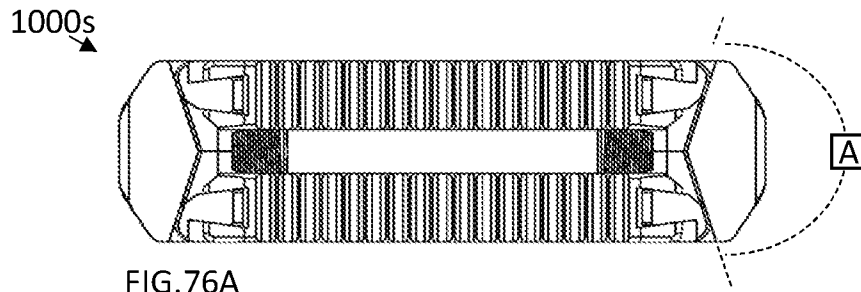

FIG.75E



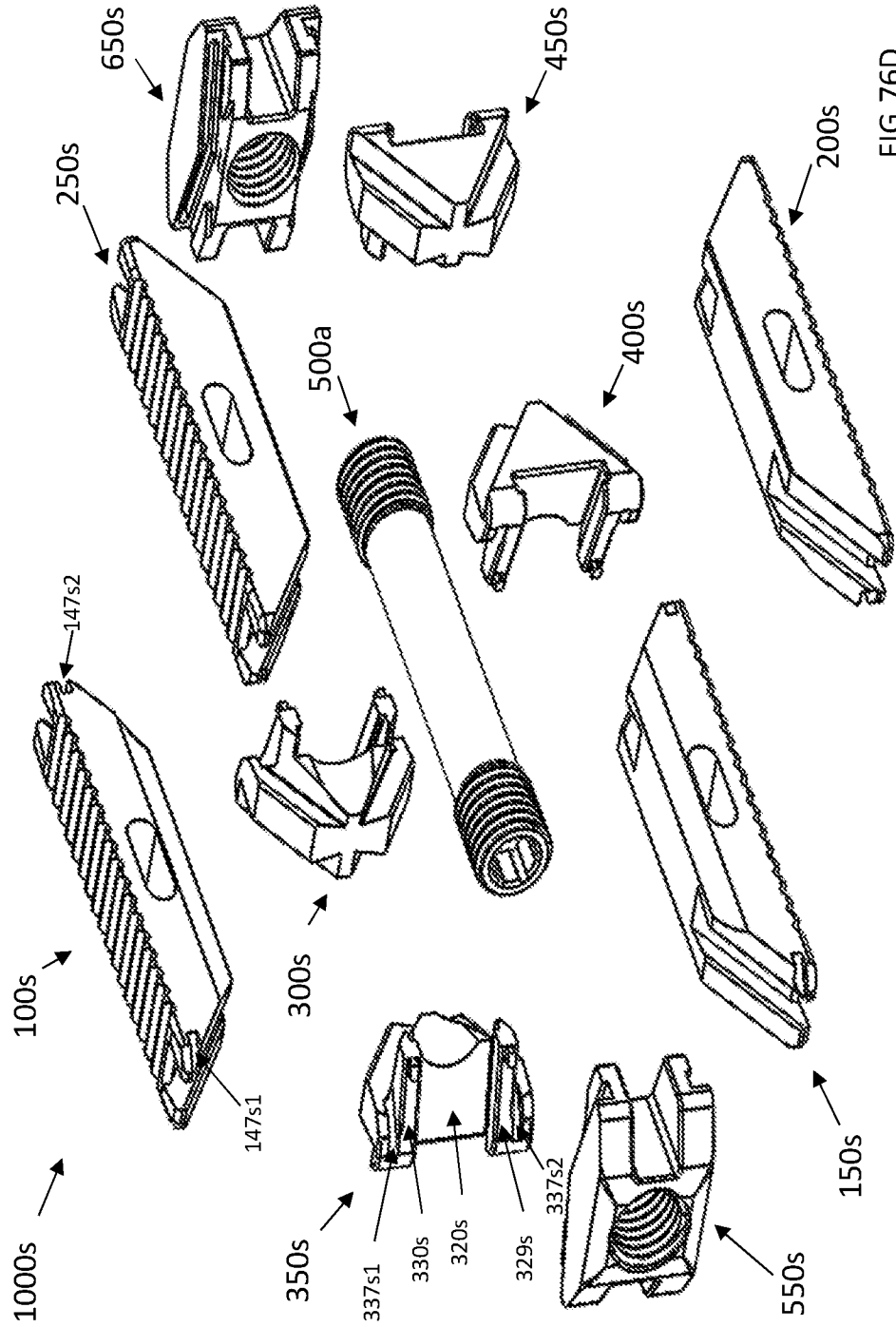
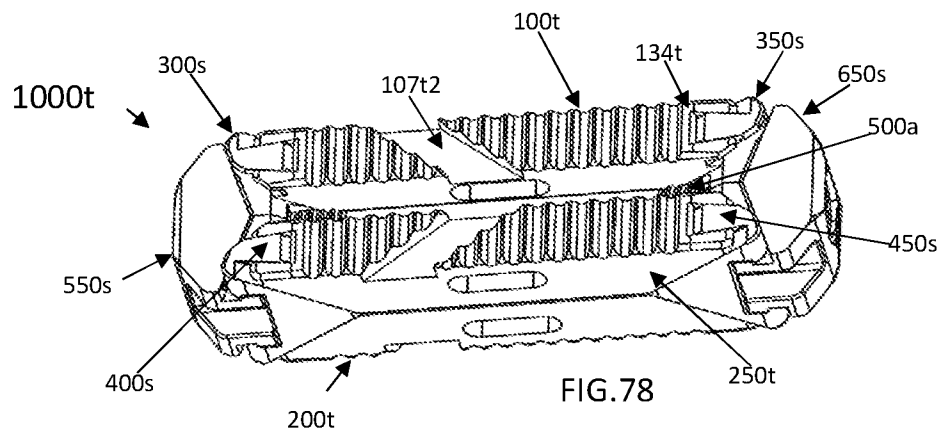
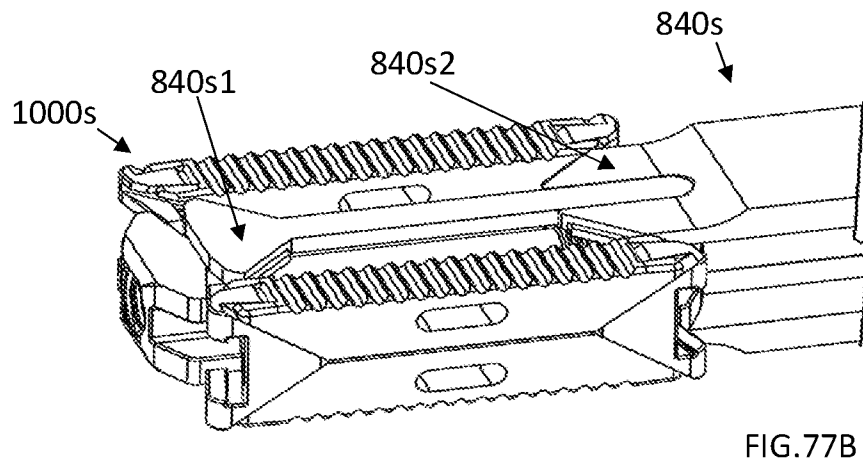
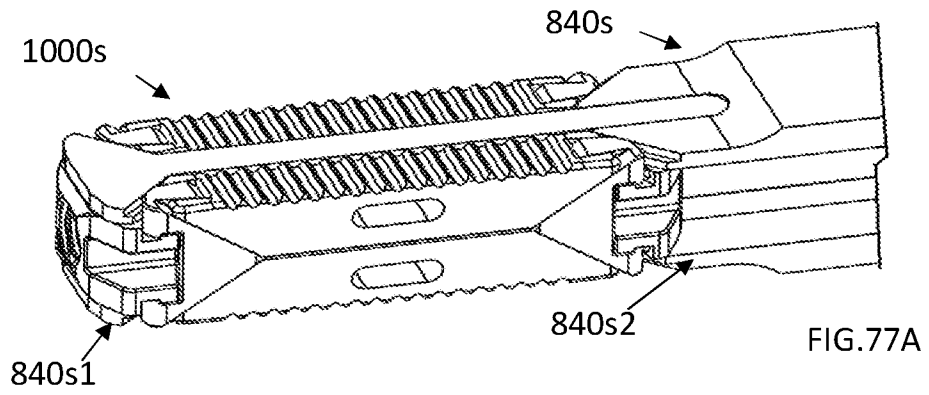

FIG.76D



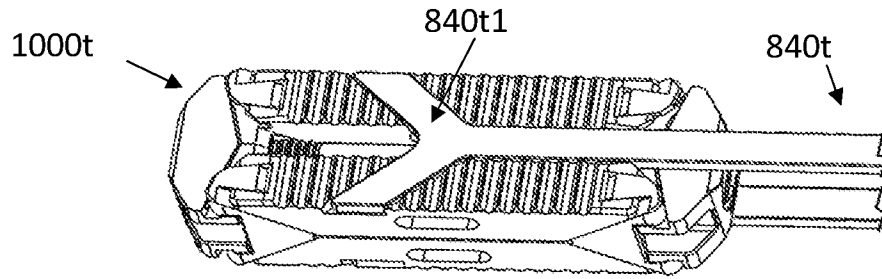

FIG. 79A

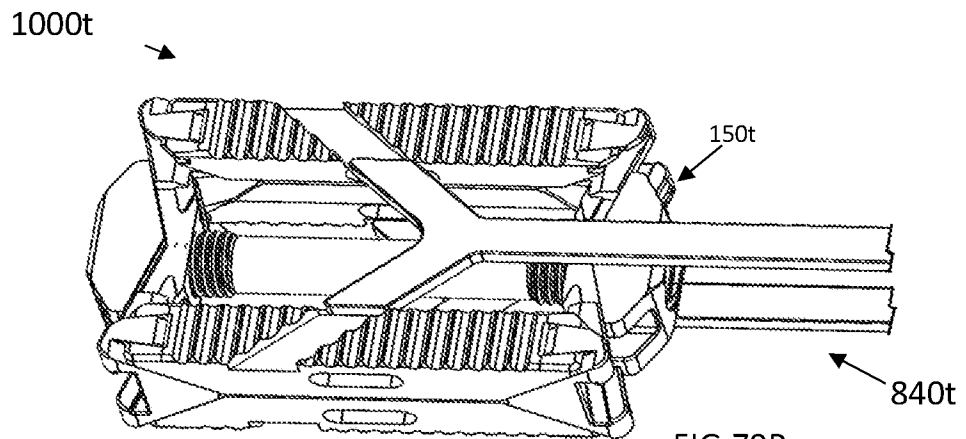

FIG. 79B

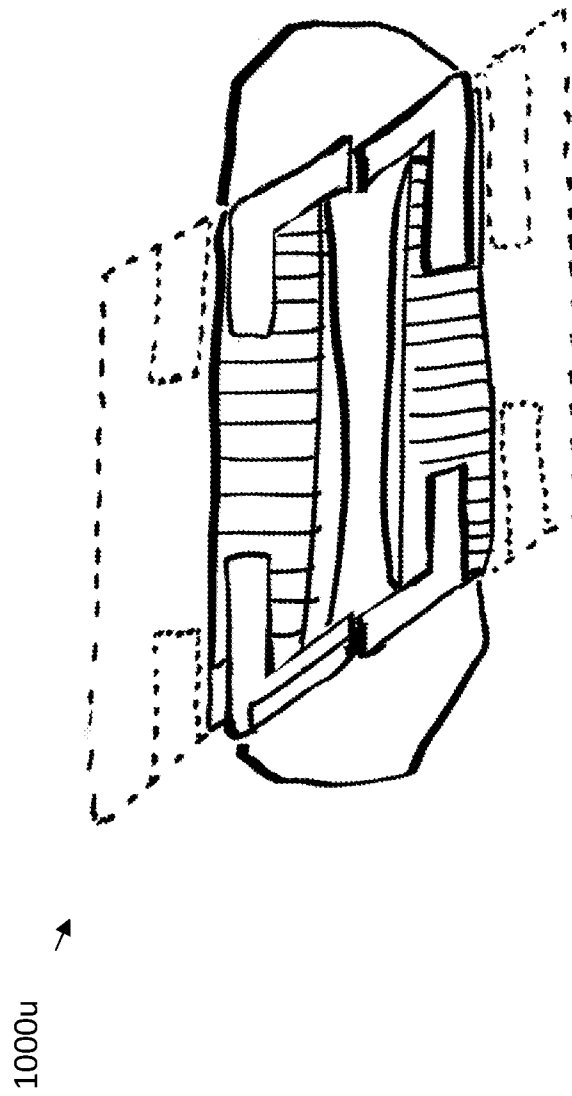

FIG.80

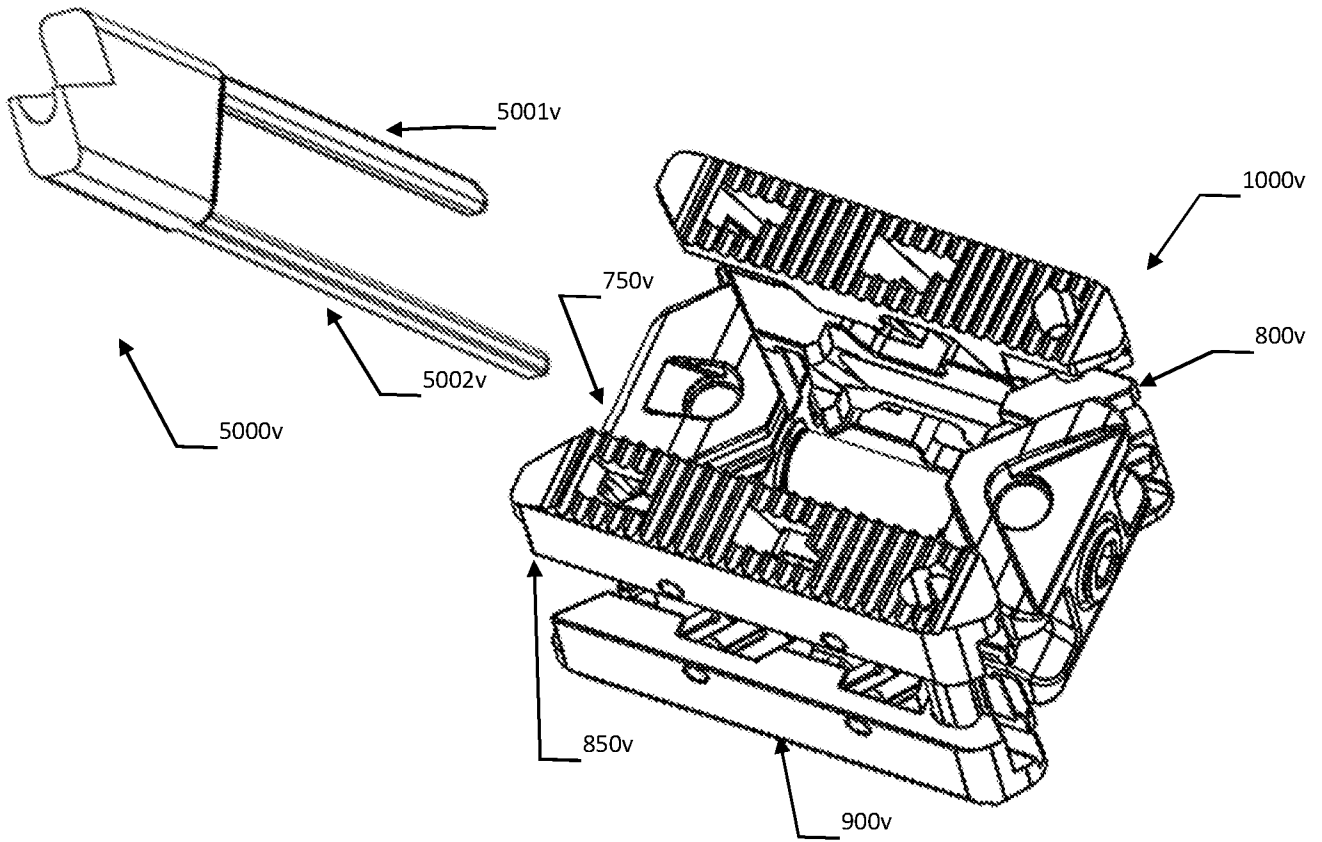

FIG 81A

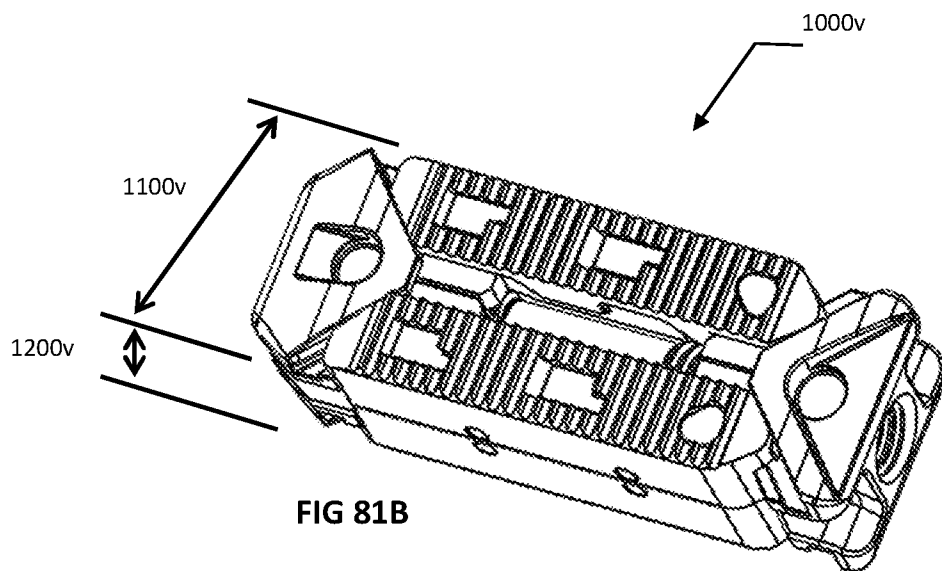

FIG 81B

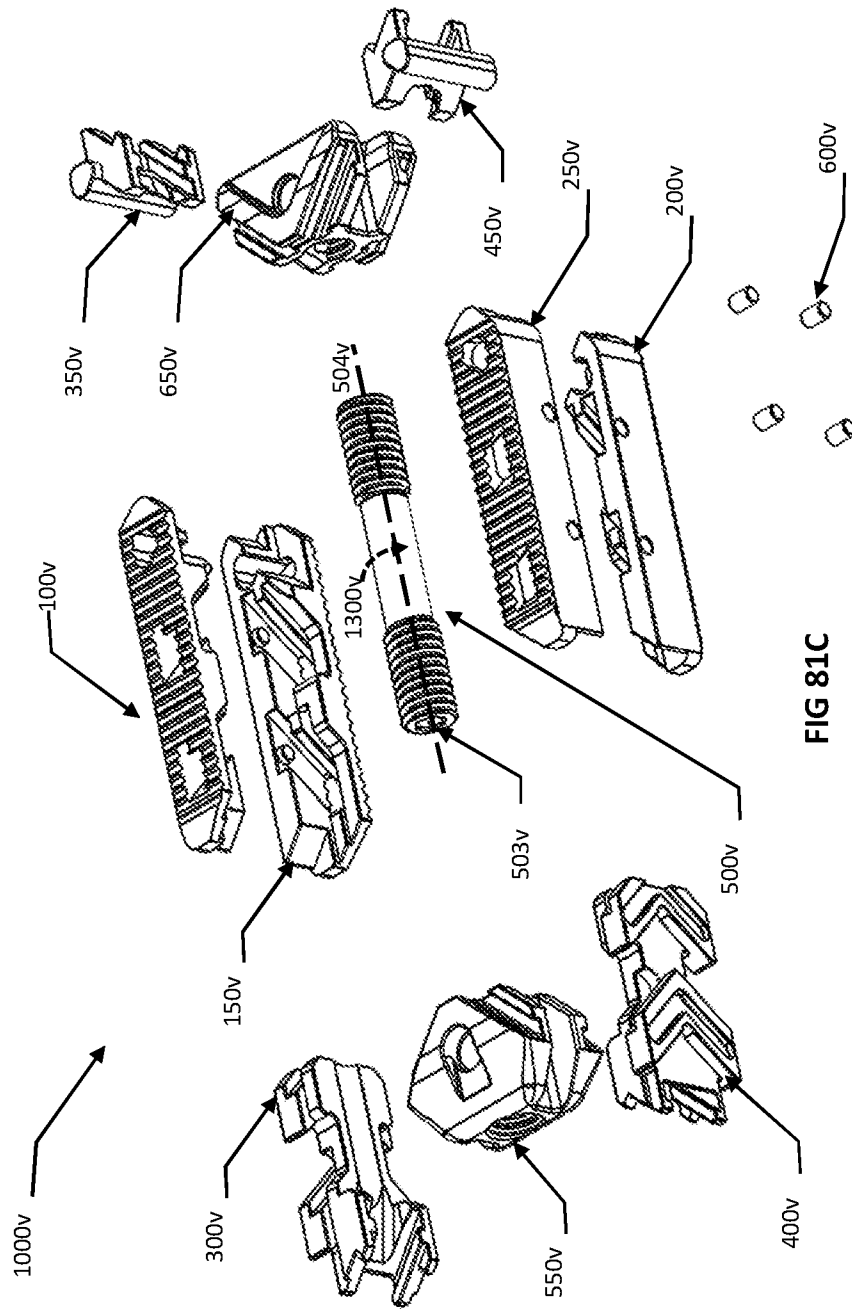
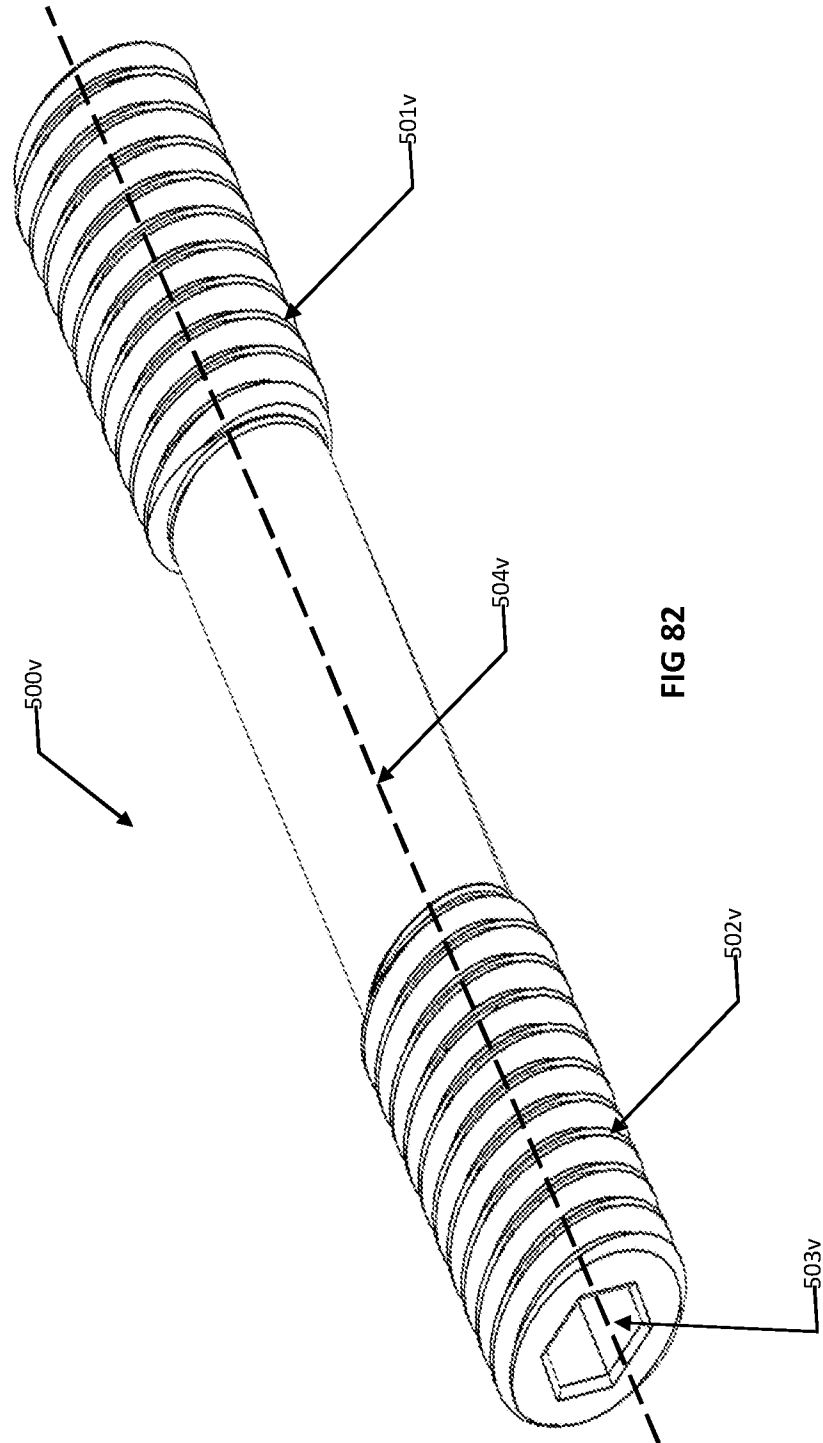

FIG 81C



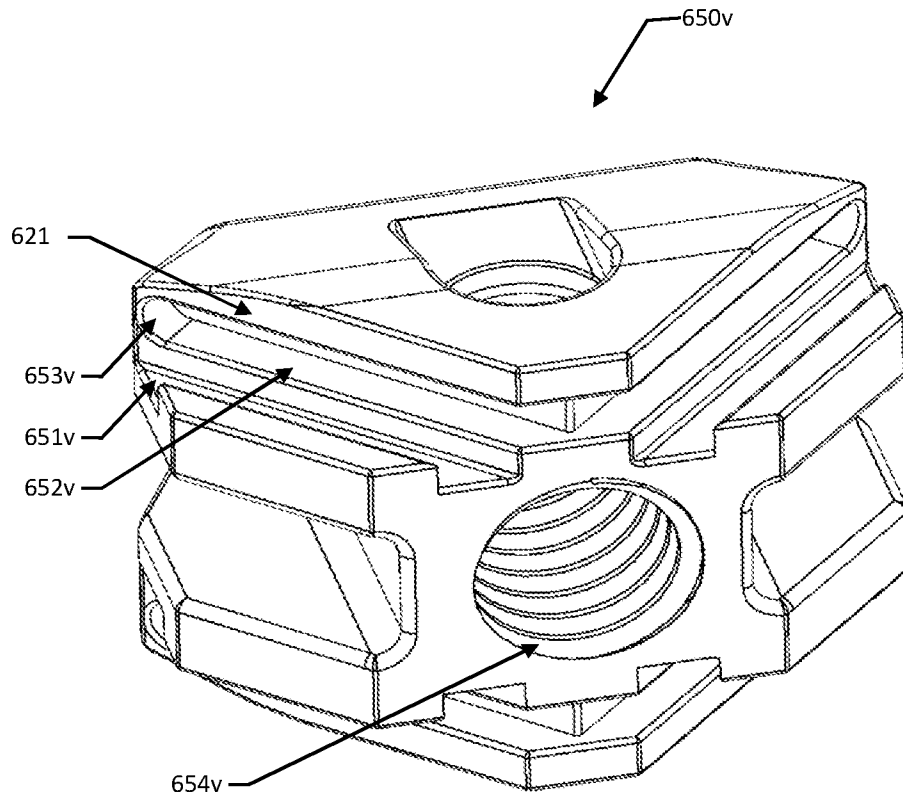

FIG 83A

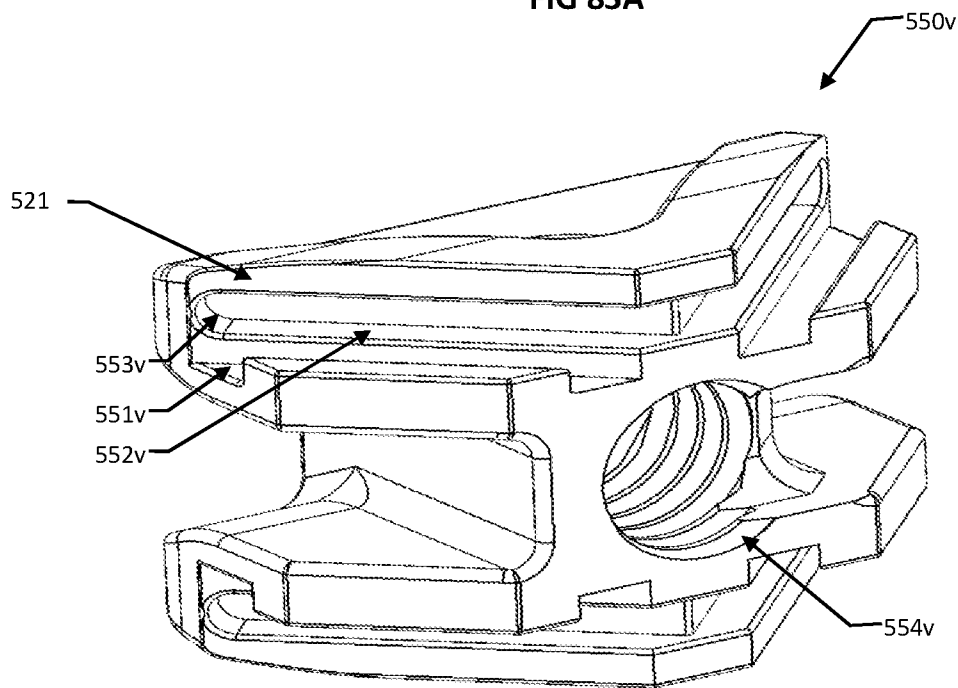

FIG 83B

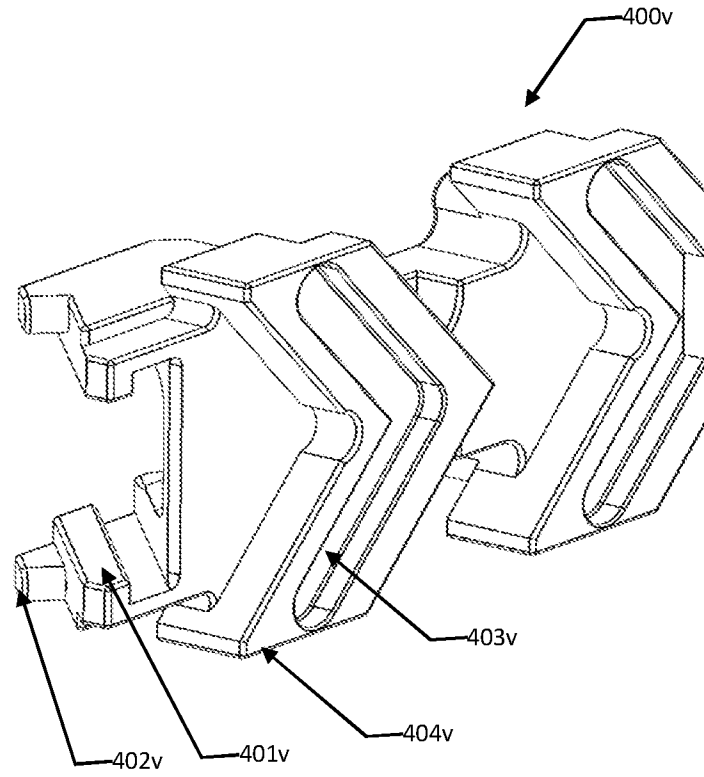

FIG 84A

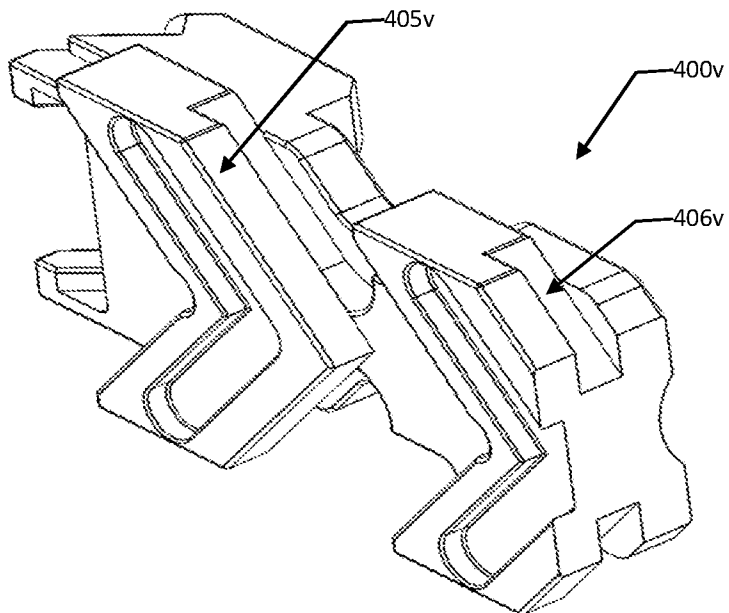

FIG 84B

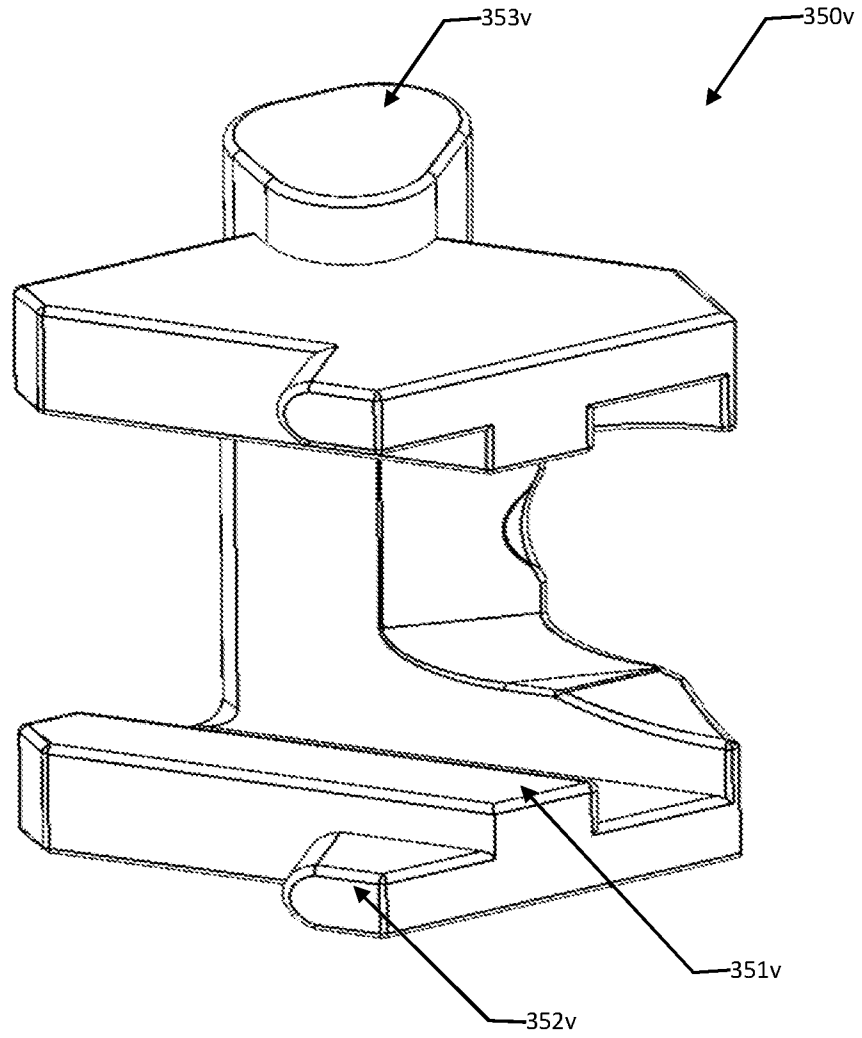

FIG 85

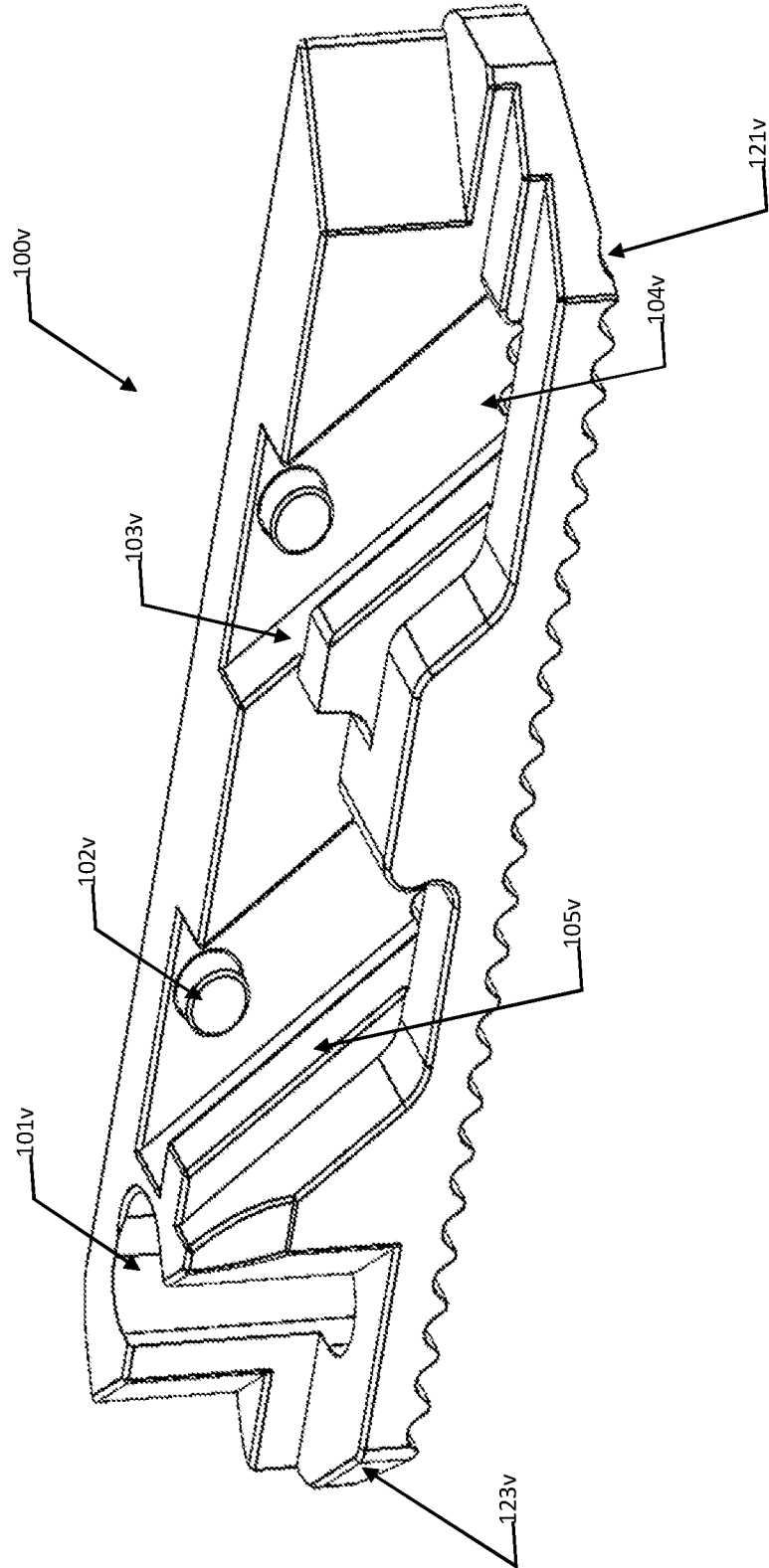

FIG 86

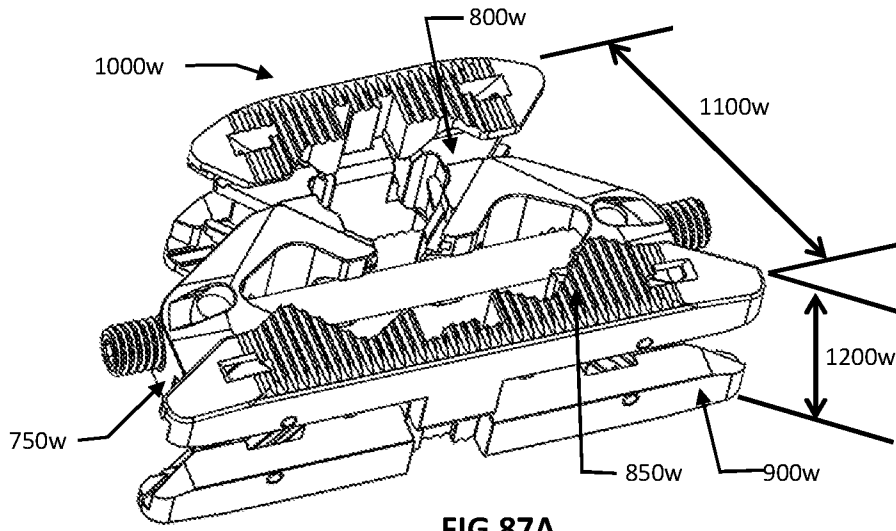

FIG 87A

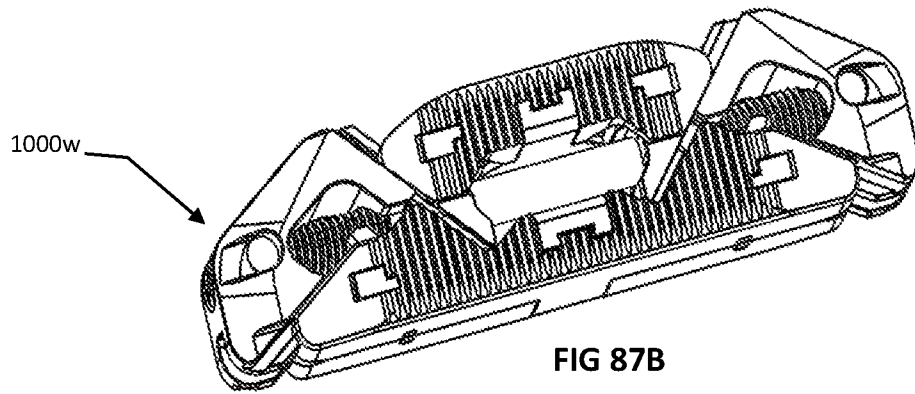

FIG 87B

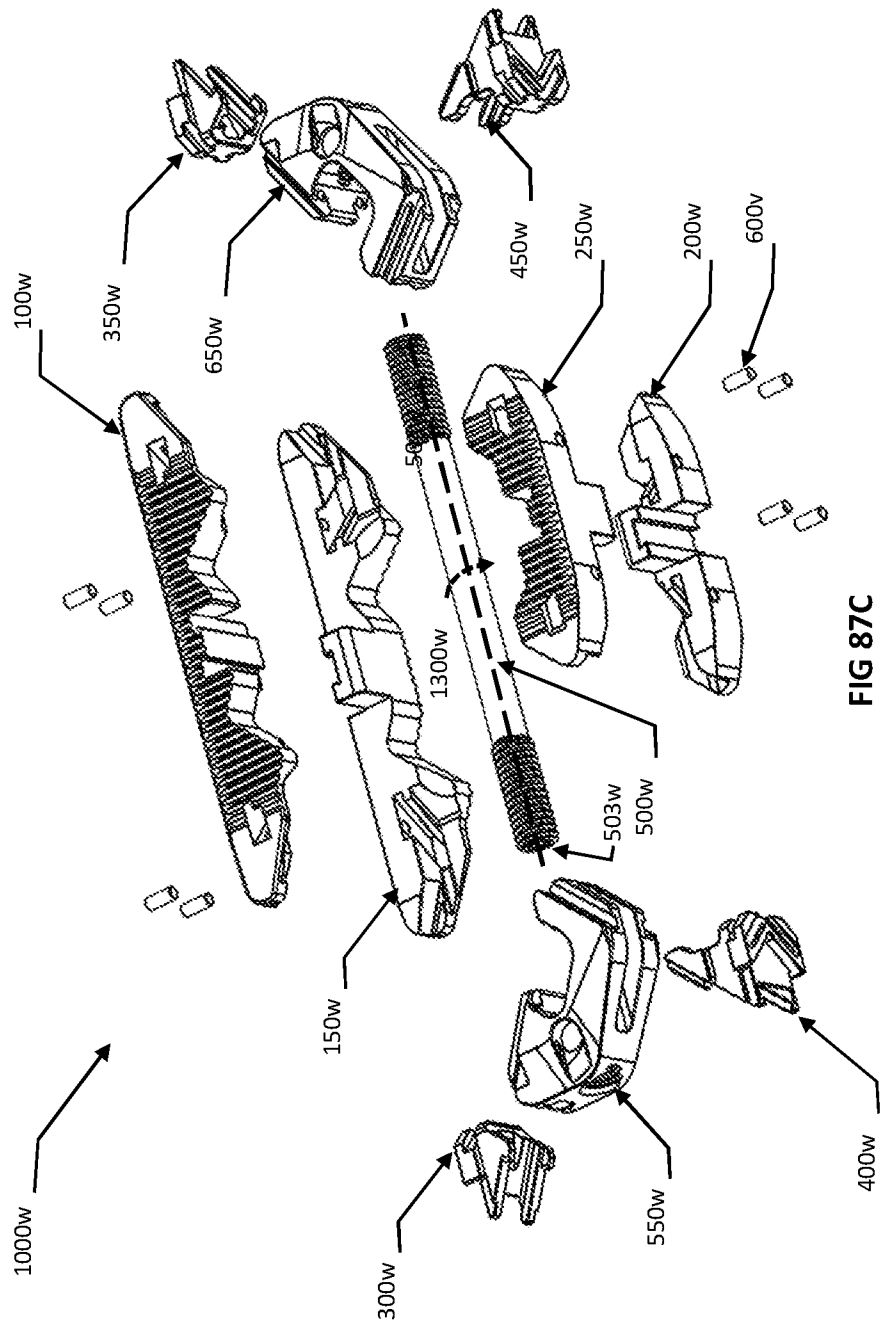
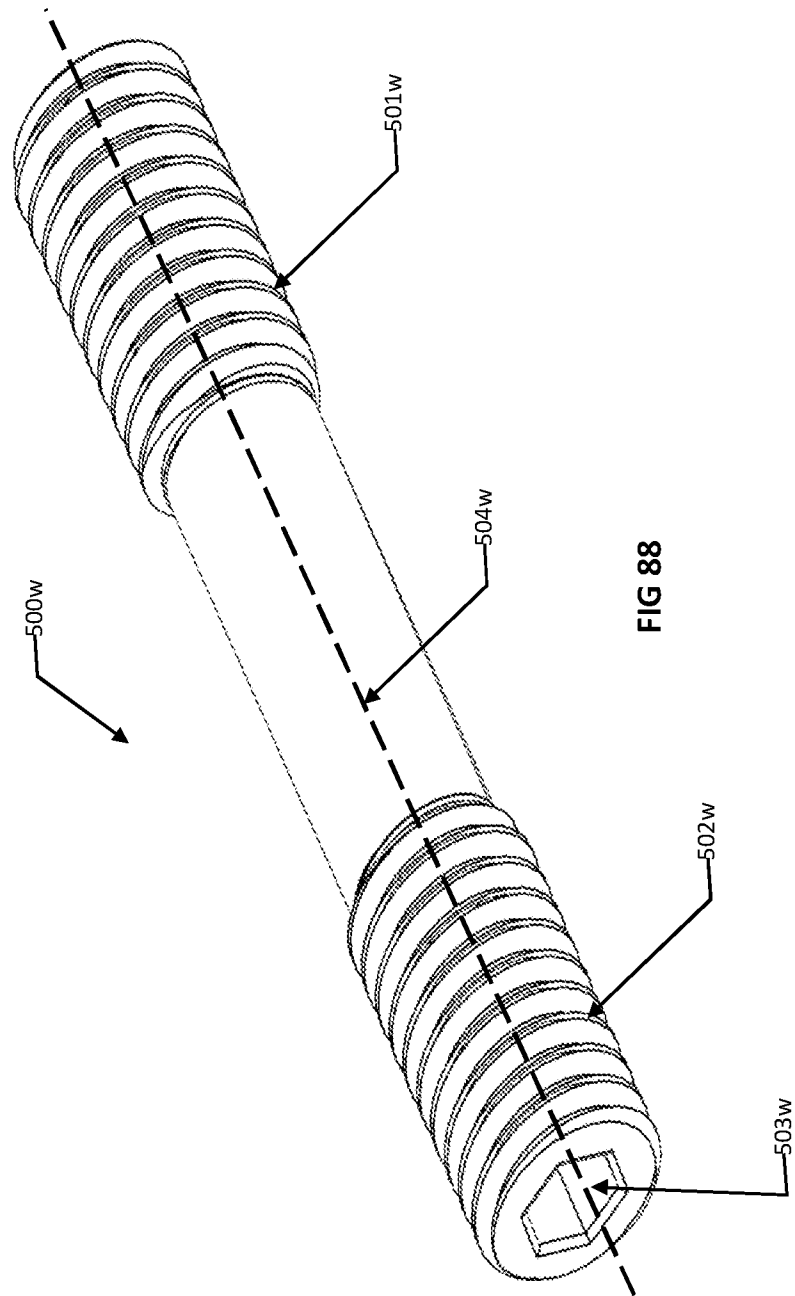

FIG 87C



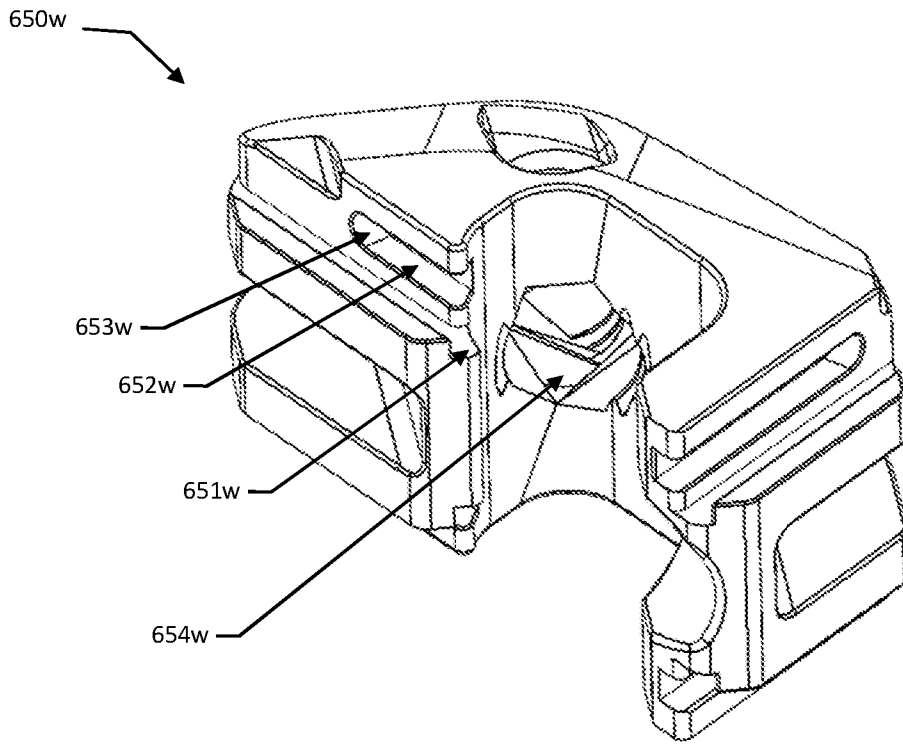

FIG 89A

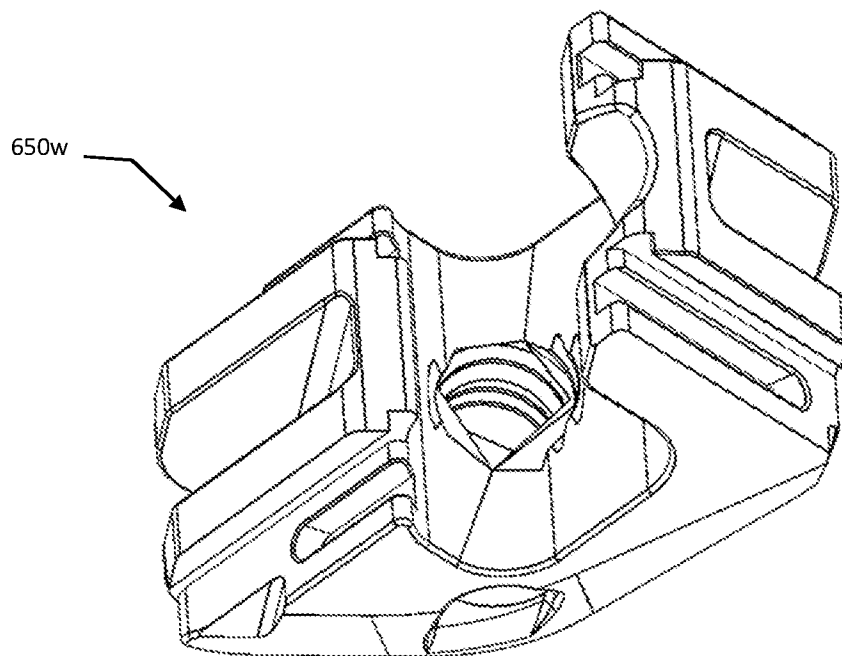

FIG 89B

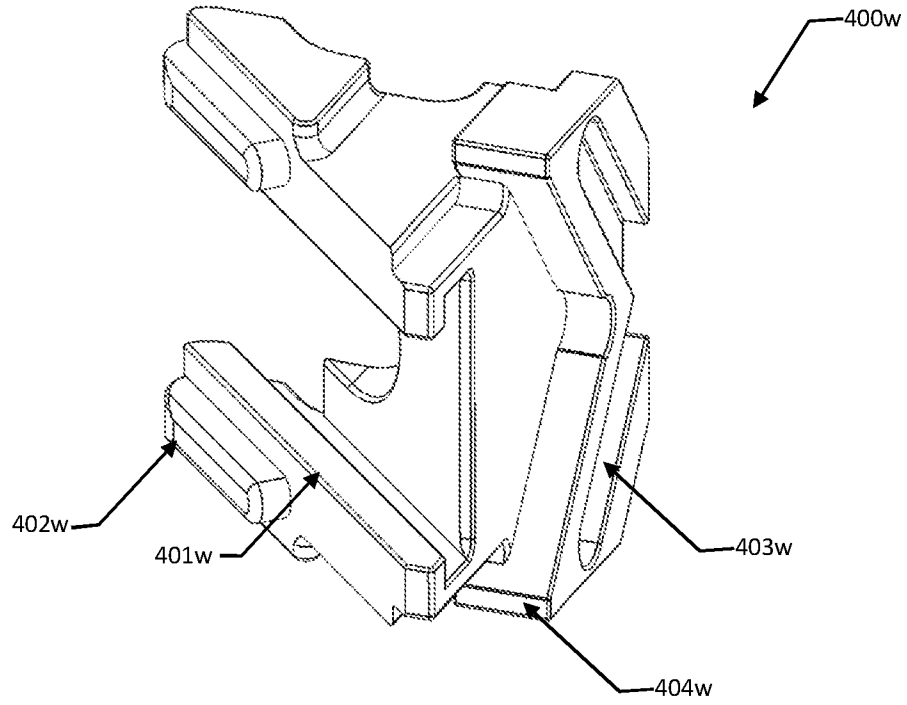

FIG 90A

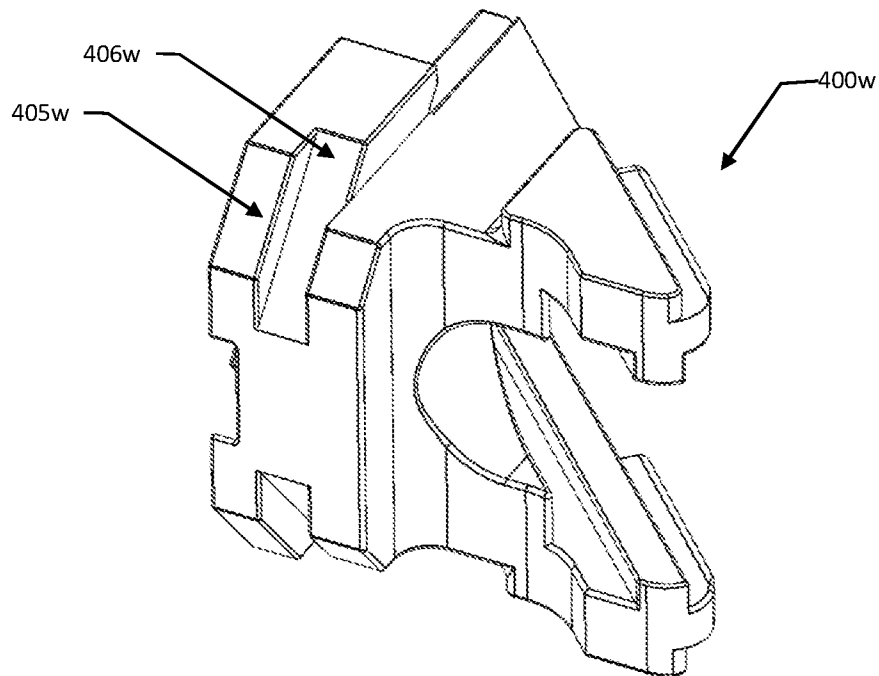

FIG 90B

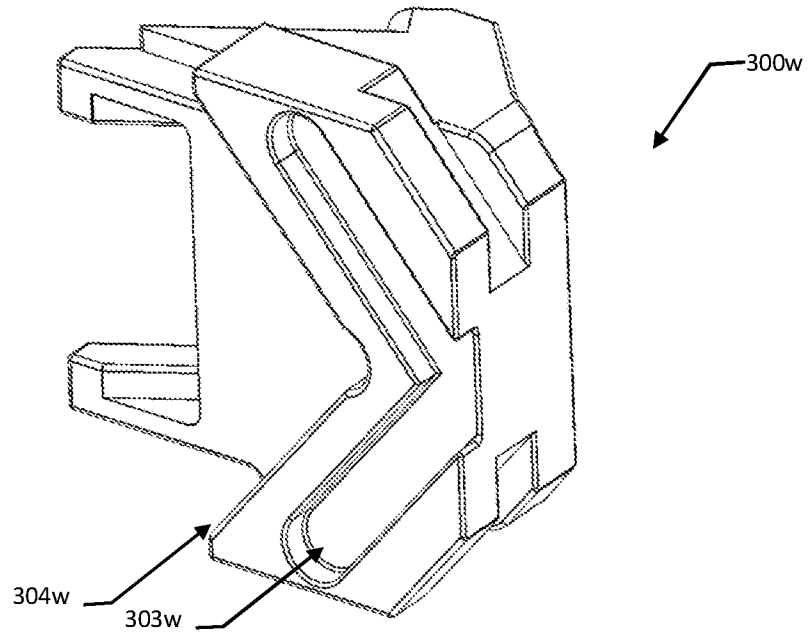

FIG 91A

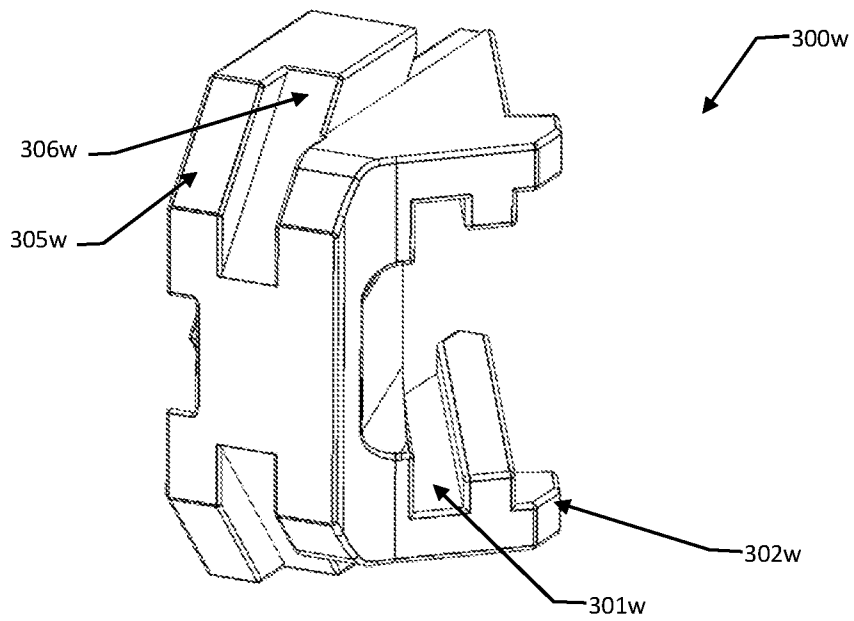

FIG 91B

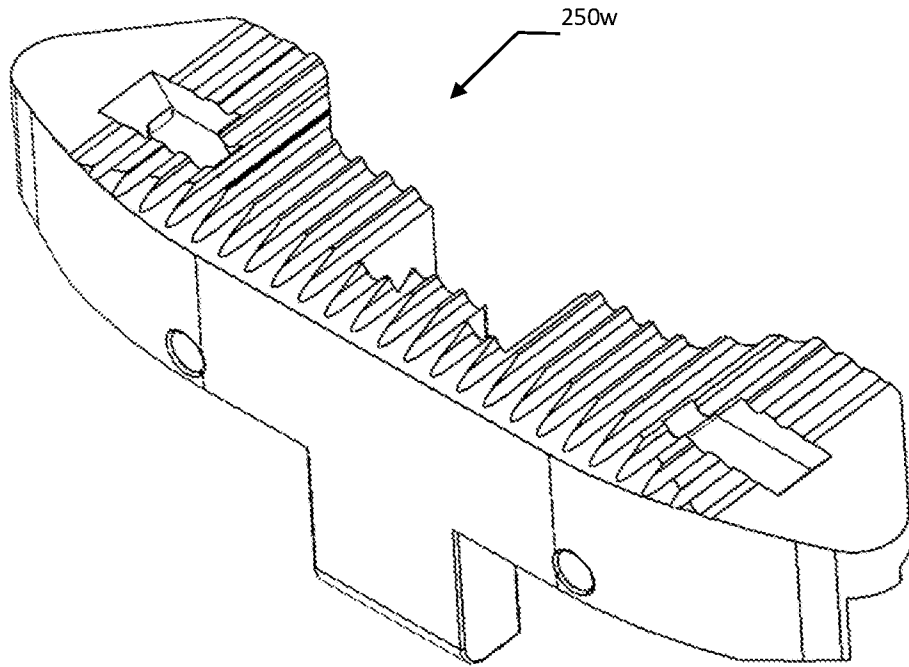

FIG 92A

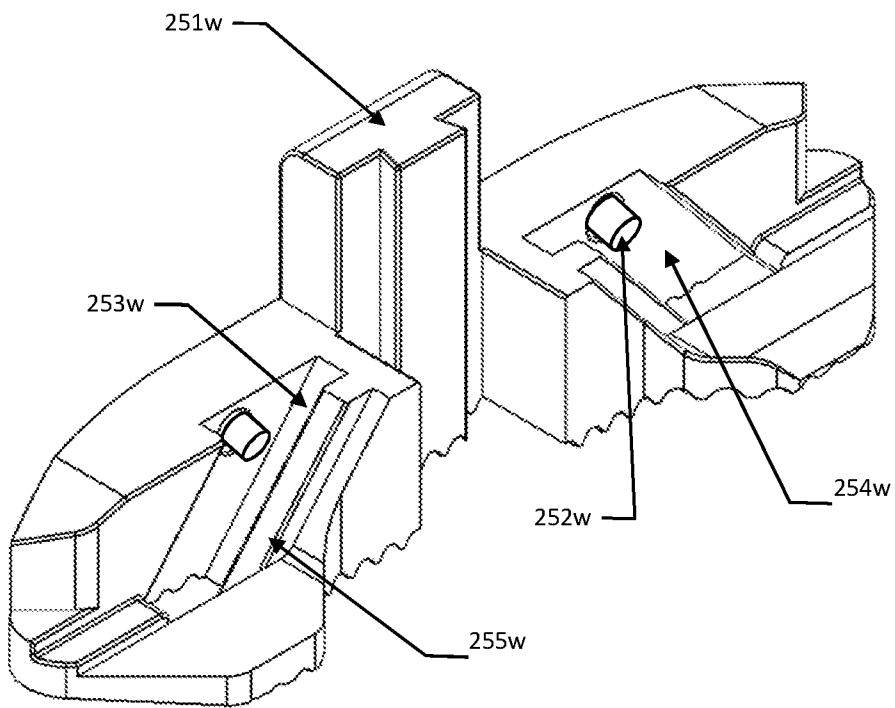

FIG 92B

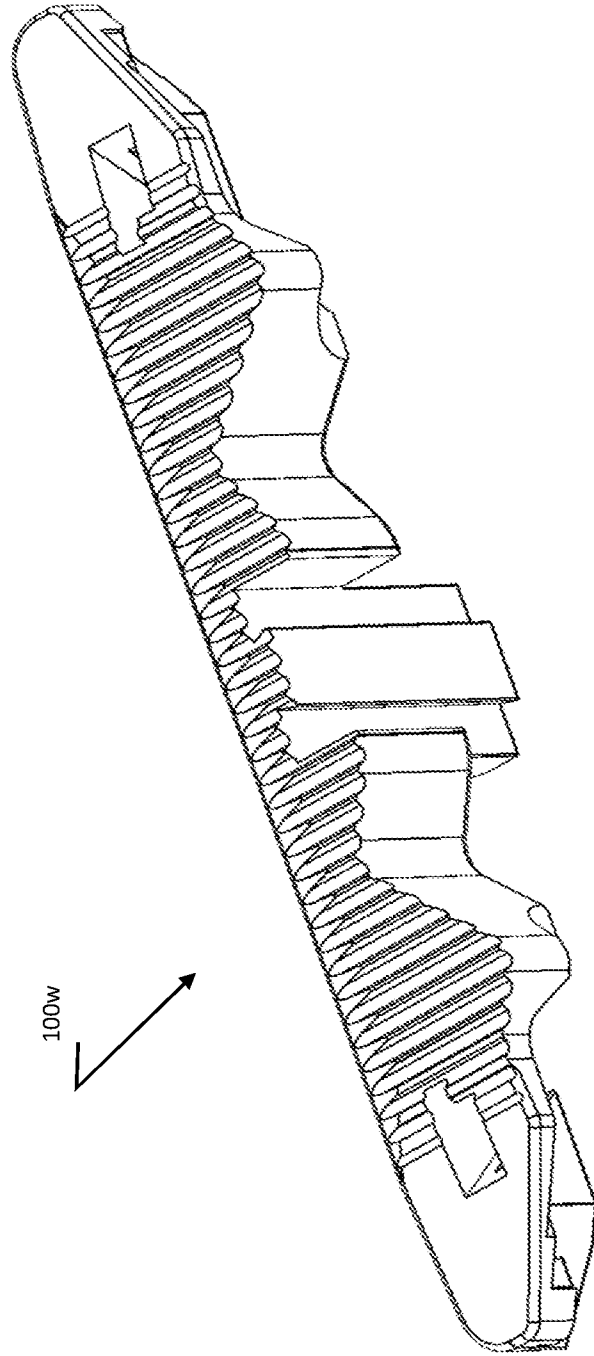

FIG 93A

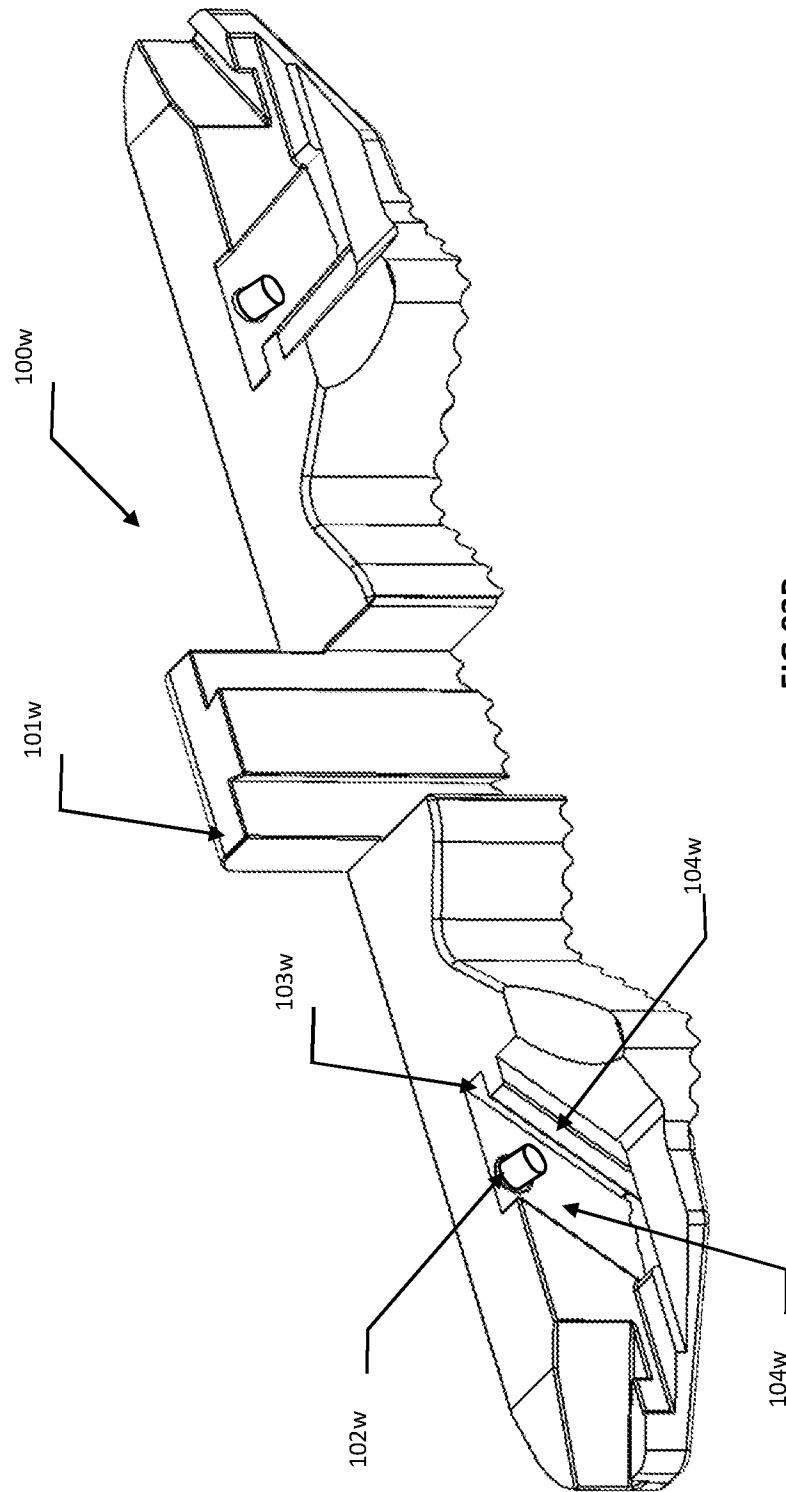

FIG 93B

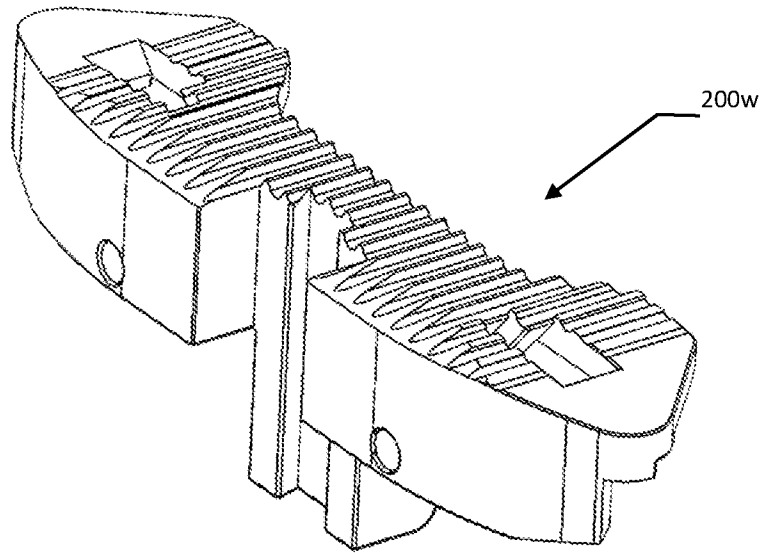

FIG 94A

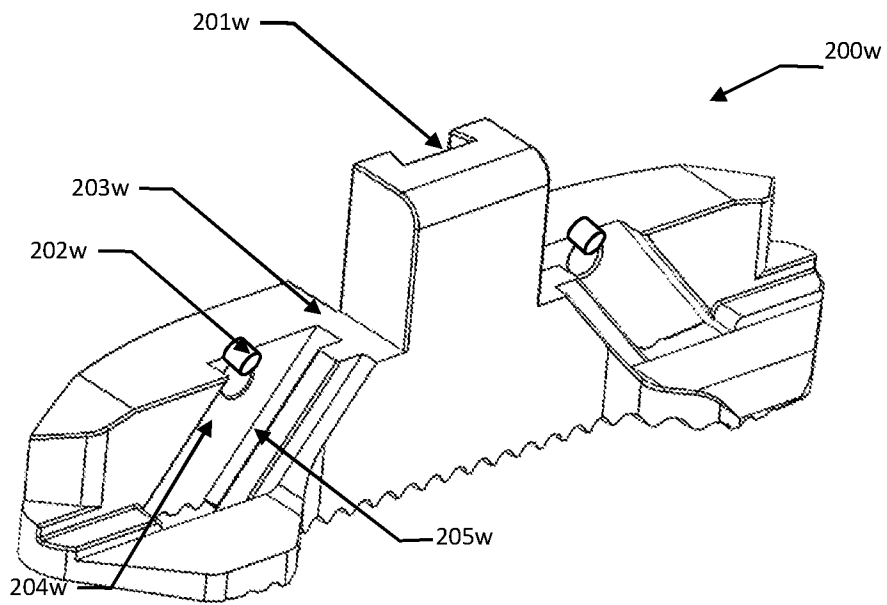

FIG 94B

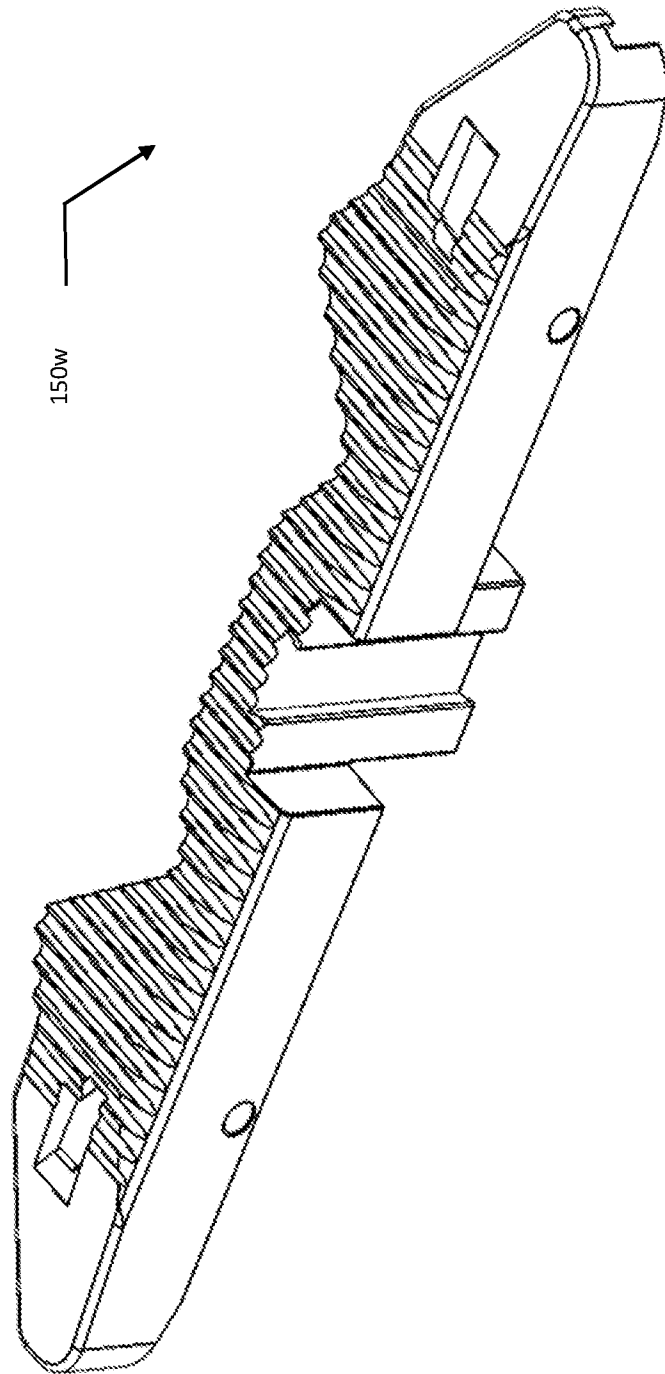

FIG 95A

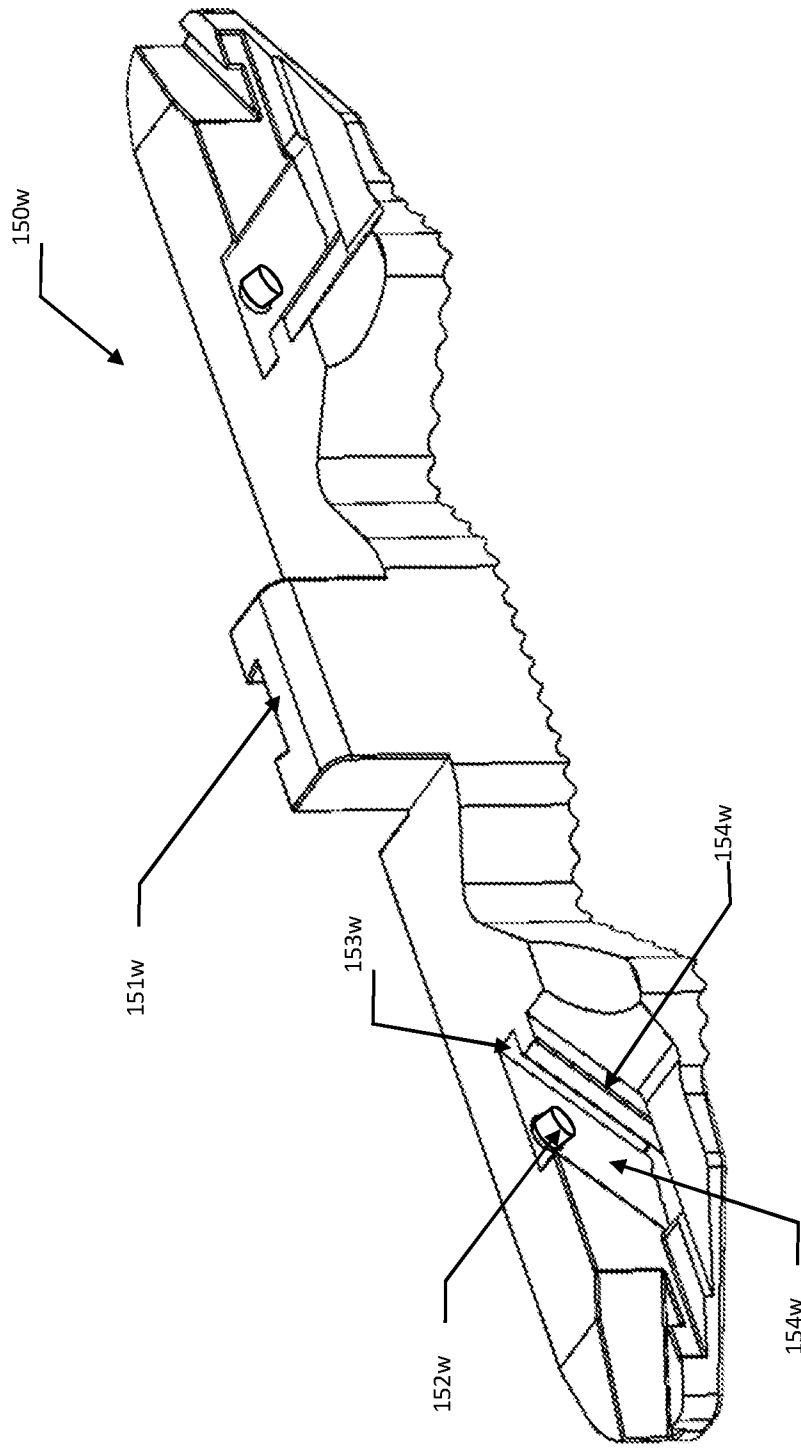

FIG 95B

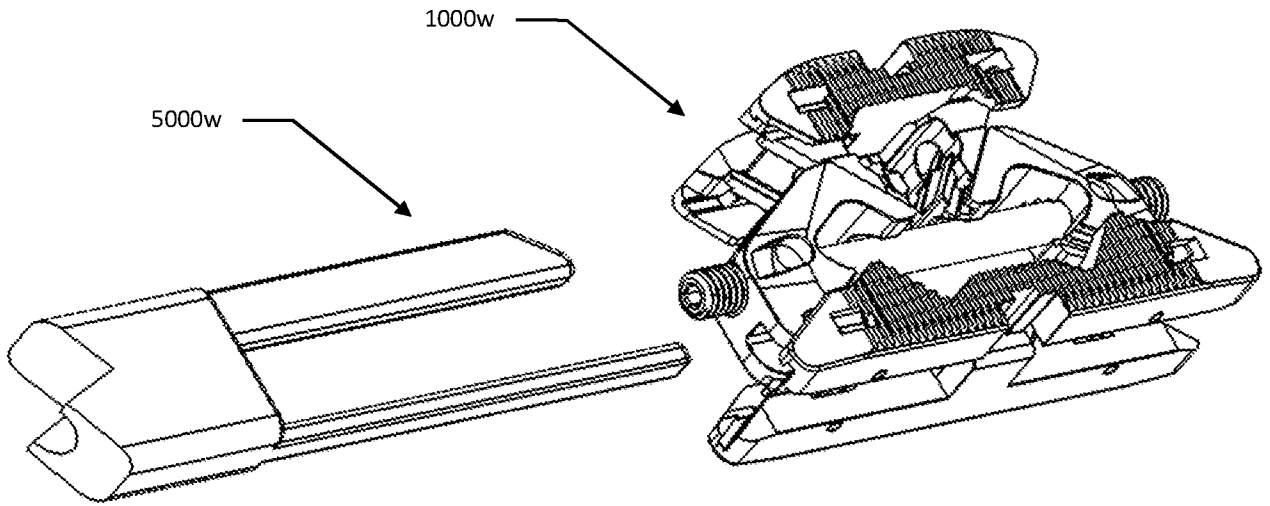

FIG 96A

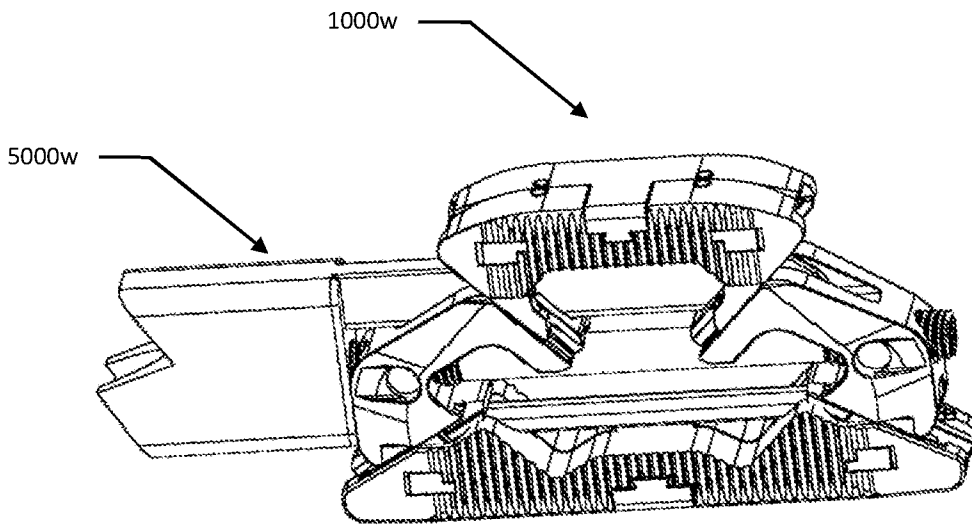

FIG 96B

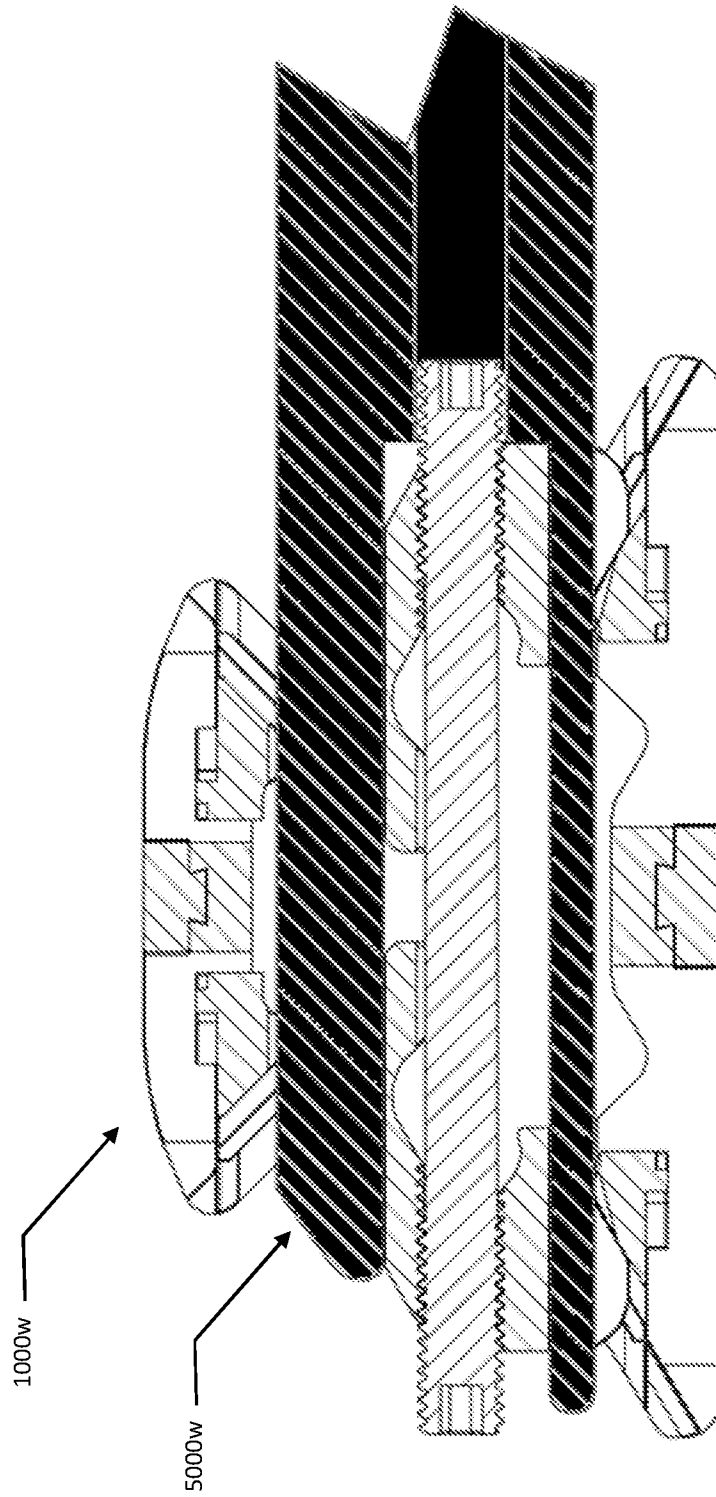

FIG 97

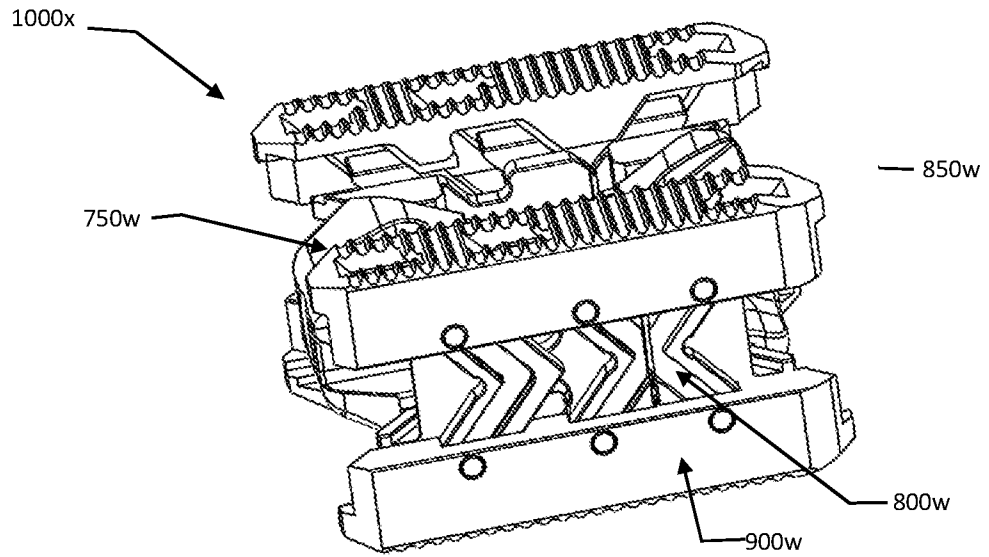

FIG 98A

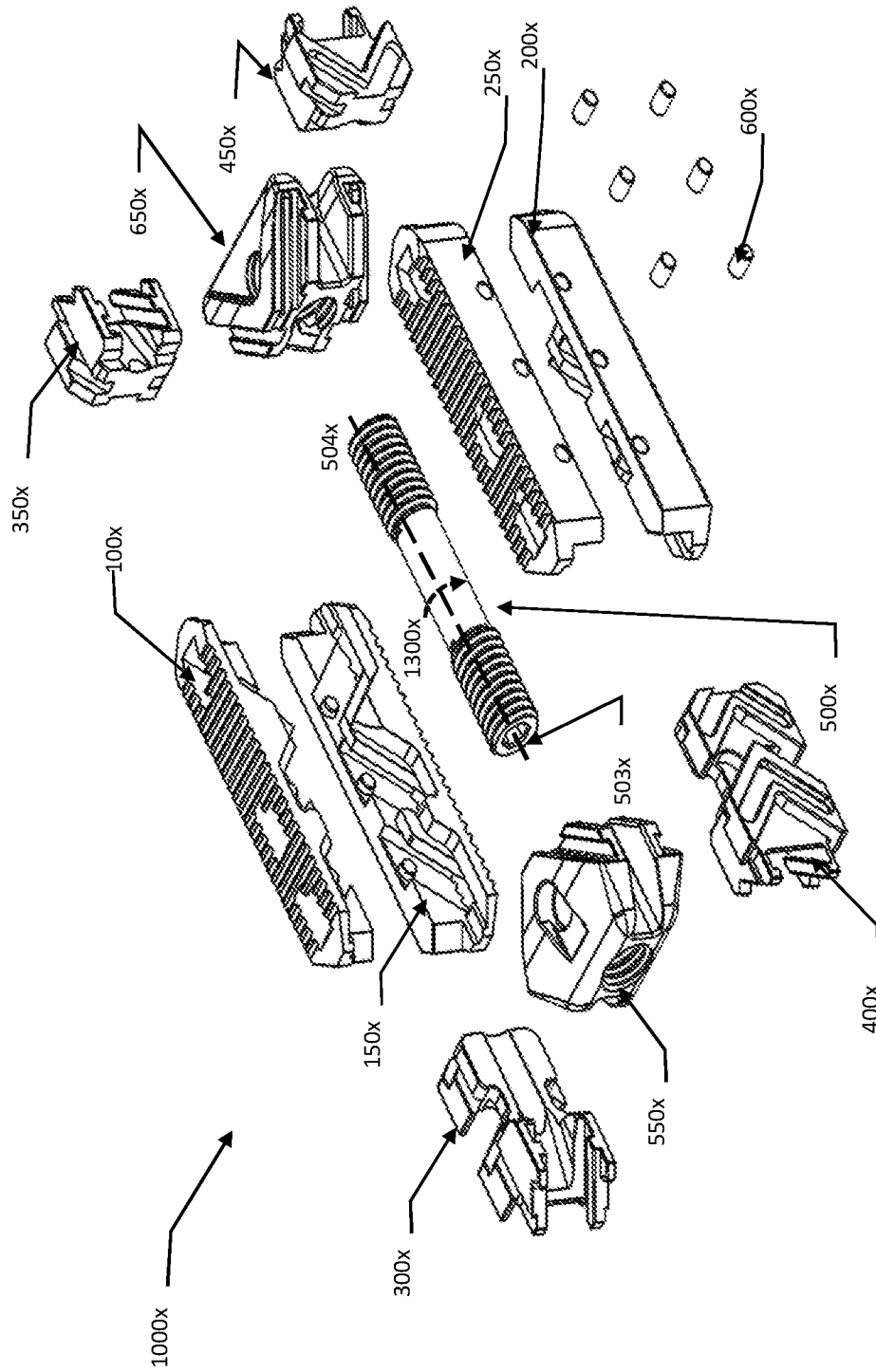

FIG 98B

