

(21) Application No 9223824.5  
(22) Date of filing 13.11.1992  
(30) Priority data  
(31) 9203234 (32) 14.02.1992 (33) GB  
9210375 14.05.1992

(51) INT CL<sup>5</sup>  
H01R 4/28  
(52) UK CL (Edition L)  
H2E EEGA  
(56) Documents cited  
GB 0531947 A EP 0116760 A1  
(58) Field of search  
UK CL (Edition L) H2E ECBB EEGA EEGB EEE  
EEGX EEH  
INT CL<sup>5</sup> H01R

(71) Applicant  
ITT Industries Limited  
  
(Incorporated in the United Kingdom)  
  
Jays Close, Viables Estate, Basingstoke, Hants,  
RG22 4BW, United Kingdom  
(72) Inventors  
Ian James Stafford Gray  
Melvin Donald White  
(74) Agent and/or Address for Service  
Elkington and Fife  
Prospect House, 8 Pembroke Road, Sevenoaks, Kent,  
TN13 1XR, United Kingdom

(54) Clamping contact onto conductor

(57) A connector (e.g. coaxial connector) comprises a body with an axially extending bore therein for receiving a cable (e.g. coaxial) and for accommodating an electrically-conductive clamp (31) located adjacent the cable (not shown) and electrically coupled with a contact (e.g. pin contact (32)) of the connector. An axially displaceable clamp driver (35, 36) causes the clamp (31) to make good electrical contact with a conductor of the cable (e.g. central conductor of coaxial cable) in response to a predetermined axial displacement of the clamp driver (35, 36). The clamp driver (35, 36) has a first positive hold position (eg detent 39) relative to the connector body in which position the clamp driver (35, 36) acts solely to retain other connector components within the connector body. By the predetermined axial displacement of the clamp driver (35, 36) from the first positive hold position to a further positive hold position (eg detent 48) good electrical contact is established between the clamp (31) and the conductor of the cable, for example by radially inward movement of fingers of the clamp.

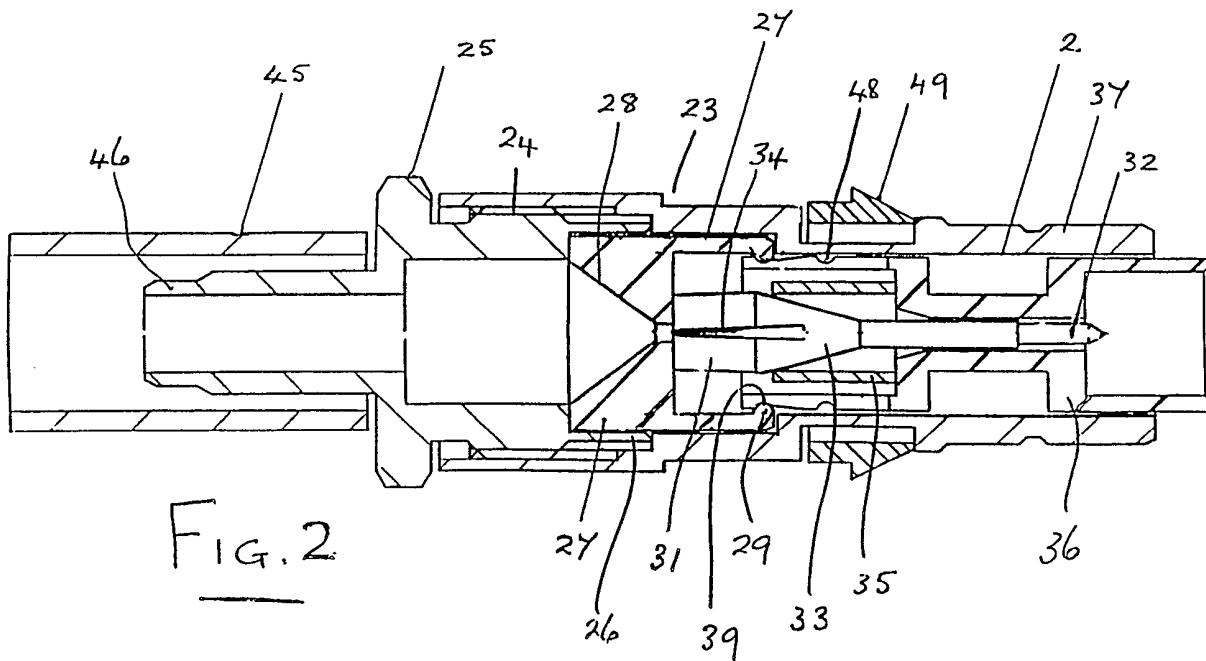

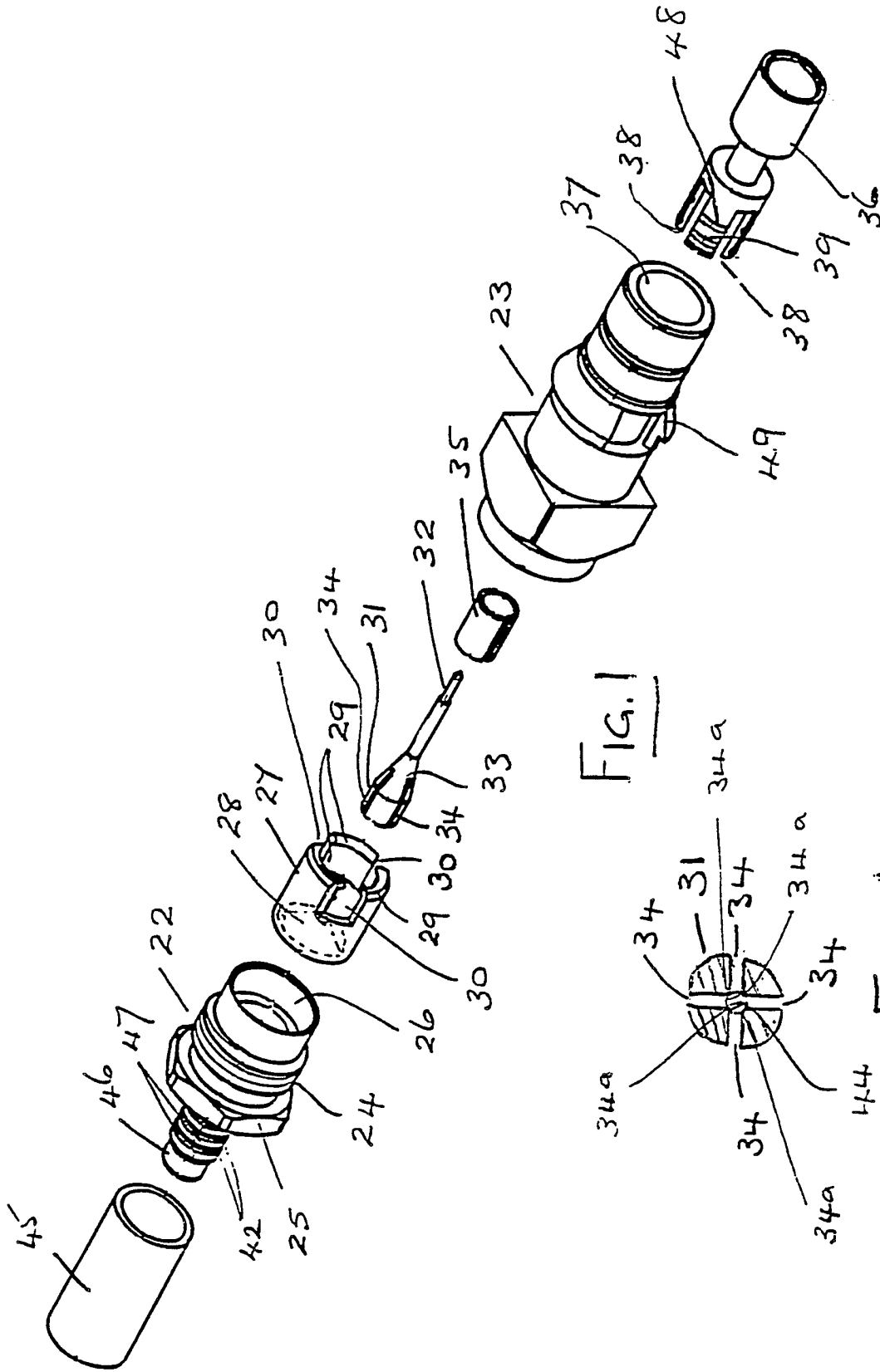

FIG. 1

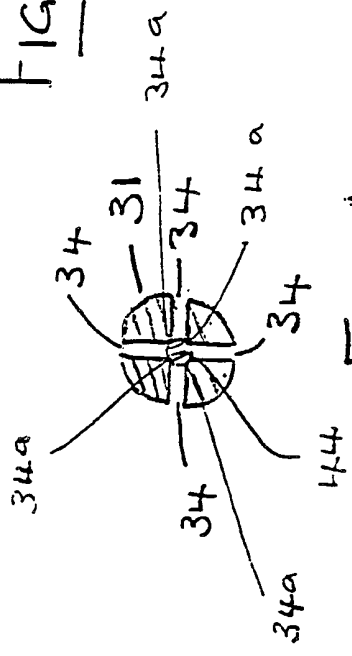

FIG. 1a

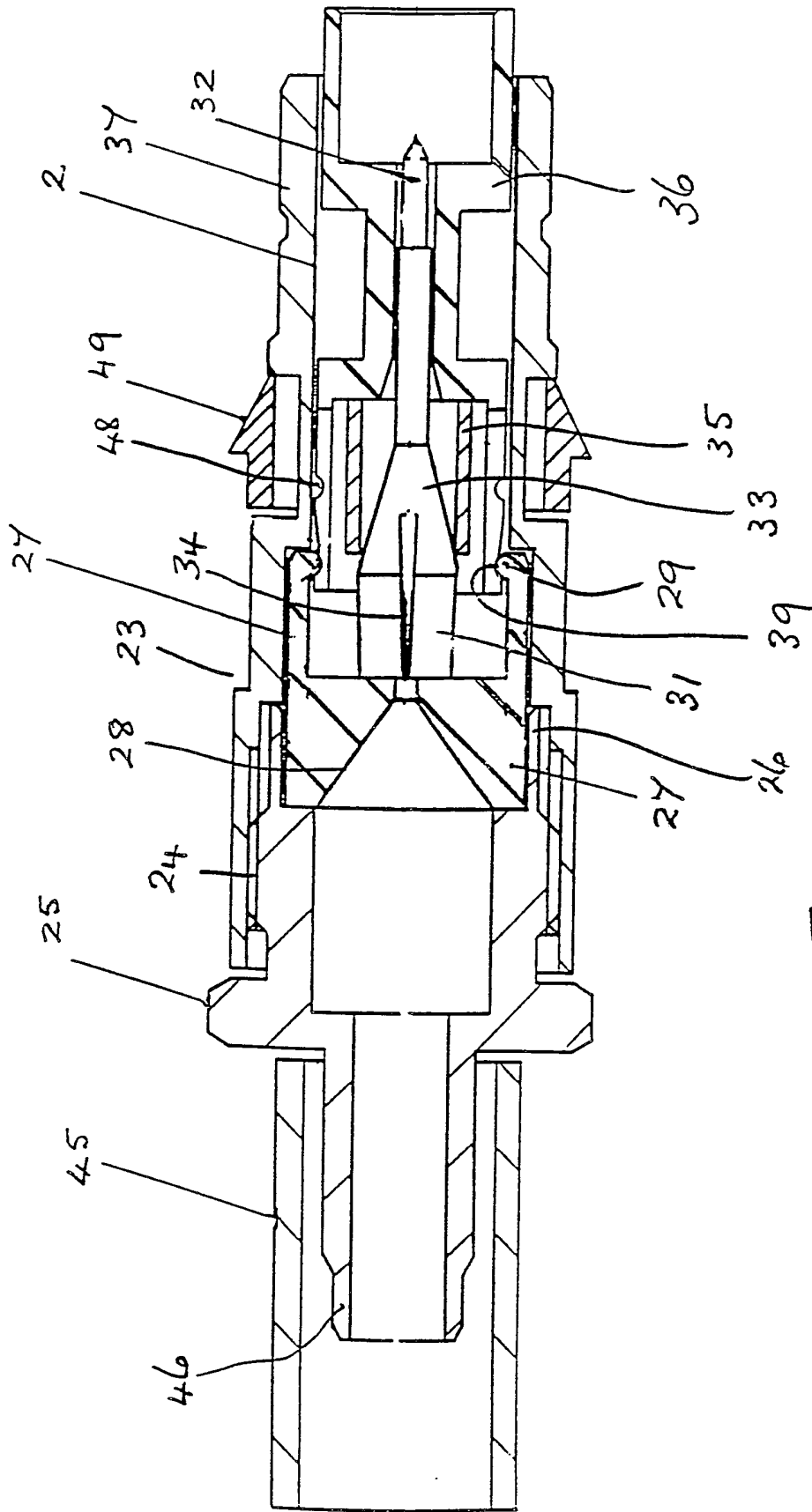
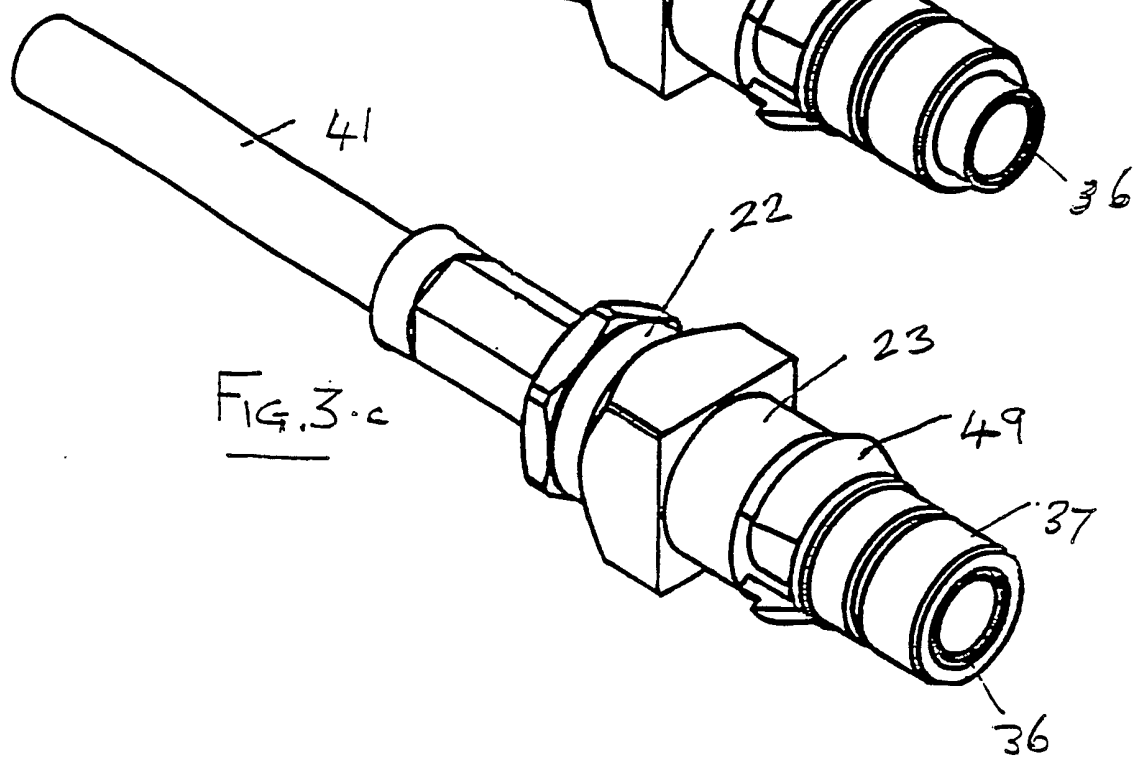
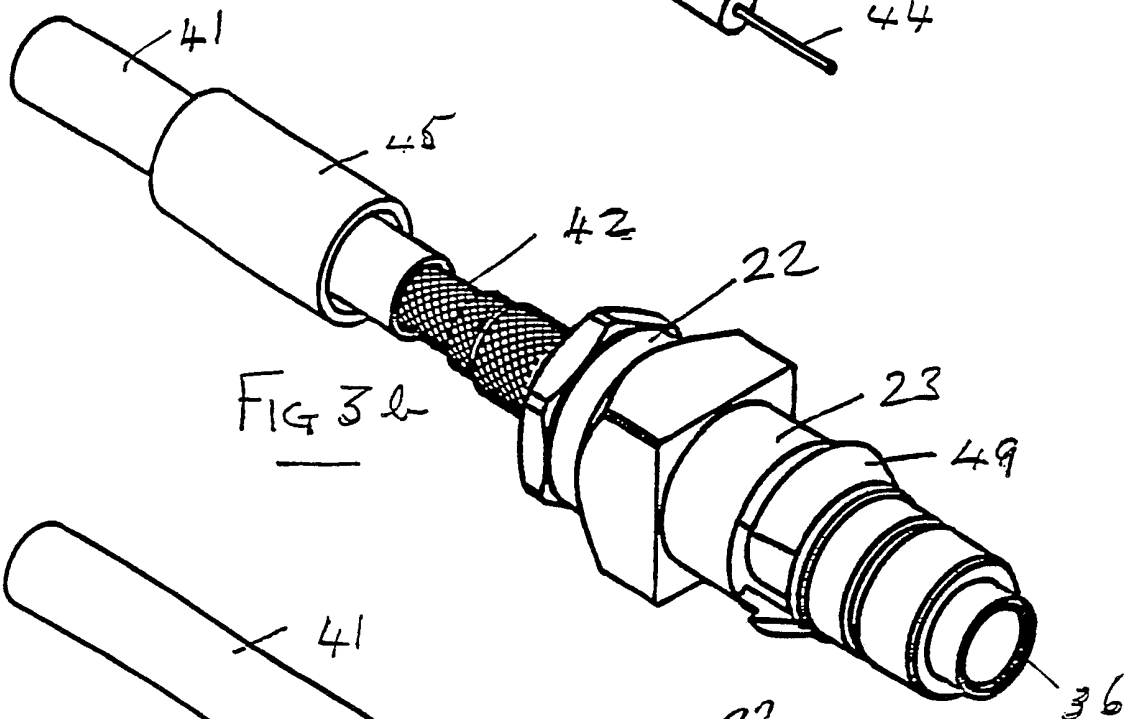
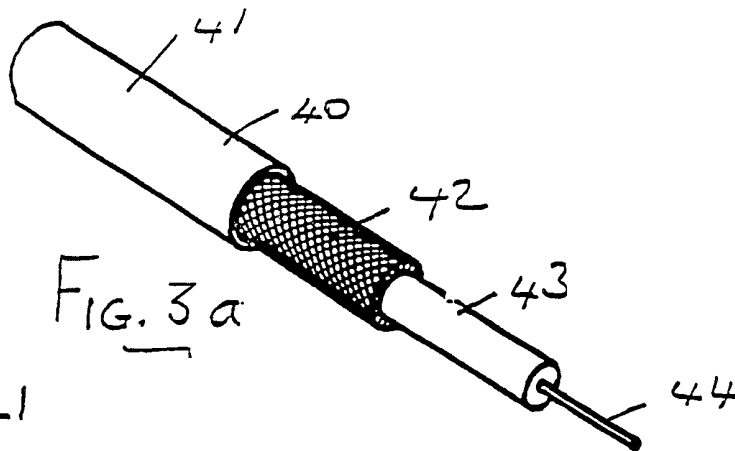

FIG. 2



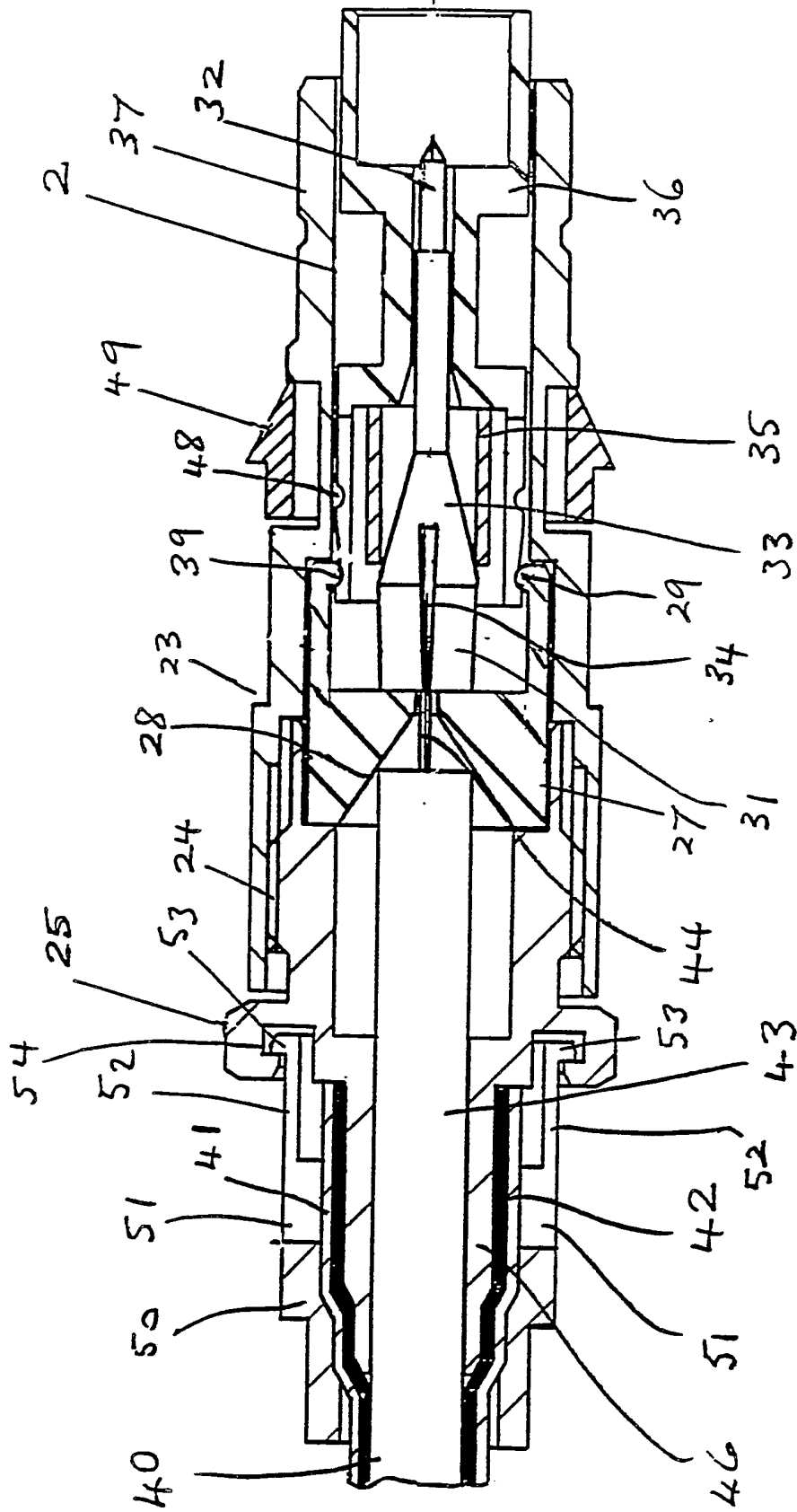

FIG. 4

ELECTRICAL CONNECTORS

This invention relates to electrical connectors.

The invention relates especially, but not exclusively to electrical connectors of the coaxial type in which an electrical connection is made between the central conductor of an incoming coaxial cable and contact means of the connector without the need for crimping and/or other tools.

According to the present invention there is provided an electrical connector comprising a tubular body structure having an axially extending bore therein for receiving an incoming cable and for accommodating electrically conductive contact-making means located adjacent a part of the cable within the tubular body structure and electrically coupled with contact means (e.g. pin contact) of the connector, and axially displaceable means at least partly received by the tubular body structure and effective to cause the contact-making means to make good electrical contact with a conductor of the cable in response to a predetermined axial displacement of the displaceable means, in which the displaceable means has at least one positive hold position relative to the tubular body structure in which position the displaceable means acts solely to retain other connector components within the tubular body structure and in which the predetermined axial displacement of the displaceable means from the positive hold position to a further position also preferably a positive hold position, establishes the

electrical contact between the contact making means and the conductor of the cable.

The positive hold position of the displaceable means advantageously provides for security against loss of internal connector parts during handling, transport and/or delivery of the connector.

In carrying out the present invention the positive hold position(s) of the displaceable means may be provided by co-operating projection(s) and groove(s) formed in the axially displaceable means and another connector component part and making snap engagement with each other in the positive hold position(s). The axially displaceable means may be arranged to exert a radially inward force on a contact-making element of the contact-making means to make good electrical contact with the conductor of the cable in response to the aforesaid predetermined axial displacement of the axially displaceable means.

The contact-making element may comprise a compressible clamping element adapted to fit over a bared part of the conductor within the tubular body structure of the connector and electrically coupled with the contact means (e.g. pin contact) of the connector. The axially displaceable means in response to movement thereof exerts a radially-inward compressive force on the clamping element to cause it to clamp down on to the conductor.

The compressible clamping element may comprise a split tubular metal part into one end of which the bared part of the conductor extends and this clamping element may be formed integrally with the contact means (e.g. pin contact) of the connector.

To positively ensure good electrical contact between the compressible clamping element and the bared conductor the actual conductor clamping region of the element may be screw-threaded or otherwise configured to bite into the outer surface of the conductor as clamping takes place.

The compressible clamping element may, for example, be provided with radial slots which have a width less than

the diameter of the central diameter and which present at the periphery of a central passage in the element for slidingly receiving the conductor, sharp edges to bite into the outer surface of the conductor to make good contact therewith when the clamping element is compressed. Four such radial slots may be provided to afford a passageway of cruciform configuration. A six slot construction of clamping element is also especially contemplated.

The compressible clamping element may be stepped on its inner surface in order to accommodate conductors of different diameters.

The axially displaceable means for exerting the radial compressive force on the clamping element may include a resilient sleeve member which initially progressively envelops the split clamping element compressing it radially inwards in response to axial displacement of the displaceable means towards the rear of the connector from the first positive hold position of said means. The resilient sleeve member may be provided by a split metal ring or by forming the sleeve of inherent resilient material (e.g. plastics material). The resilient sleeve may be engaged by or attached to or formed integrally with a tubular insulating member which is slidably mounted in the bore of the tubular body structure at the contact end of the connector. The contact means may be coupled to a relatively large diameter clamping element by a split frusto-conical section which facilitates smooth and easy transition of the resilient sleeve member from the cone surface on to the outer periphery of the clamping element in order to compress the element radially inwards when the front end of the tubular insulating member is displaced axially towards the rear end of the connector. Displacement of the tubular insulating member may, for example, be arrested once the resilient sleeve member is positioned over the clamping element as by the abutment of the rear end portion of the member with shoulder means of a cup-shaped insulating stop member located within the bore of the tubular member and



having a tapered opening therethrough for the passage of the conductor of the cable.

It is also contemplated that the axially displaceable means may include a rigid or non-resilient sleeve member which may be engaged by or attached to a tubular insulating member slidably mounted in the bore of the tubular body structure at the contact end of the connector and which moves over resilient contact-making means in order to exert thereon an inward pressure to cause the resilient contact-making means to make pressure engagement with the conductor of the cable.

In the case of a resilient sleeve member or a non-resilient sleeve member, the sleeve member and the contact-making means co-operate when the sleeve member is fully positioned thereon to provide ongoing pressure engagement between the contact-making means and the conductor of the cable without the need for a continuing applied axial force on the sleeve member of the axially displaceable means.

The connector construction of the present invention is especially applicable to co-axial connectors for clamping down on to the central conductor of a coaxial cable but it should be understood that it could be used for making connections to the conductor or conductors of other cables by way of single or multi-way non-coaxial connectors.

For the purpose of gripping the incoming cable (e.g. coaxial cable) at the end of the connector where the cable enters a suitable strain-relief arrangement may be provided.

By way of example the present invention will now be described with reference to the accompanying drawings in which:

Figure 1 shows an exploded view of a coaxial cable connector according to the present invention;

Figure 1a shows an enlarged detail of Figure 1;

Figure 2 shows a longitudinal cross-sectional view of an assembled coaxial cable connector substantially as shown in exploded form in Figure 1;

Figures 3a, 3b and 3c show different steps in the connection of an incoming cable to the connector of Figure 1; and,

Figure 4 shows a longitudinal cross-sectional view  
5 of another coaxial cable connector similar to that of Figure 2 but having a different cable strain relief arrangement.

Referring to Figure 1 of the drawings, the embodiment depicted therein in exploded form comprises a coaxial connector facilitating a pre-conductor clamping  
10 assembled state.

The tubular body structure of the connector comprises two generally cylindrical metal parts 22 and 23, the body part 22 having an externally-threaded portion 24 which, as facilitated by the integral nut head 25, can be  
15 screwed into an internally-threaded portion (not shown) of the body part 23. The body part 22 includes a cylindrical cavity 26 which slidably receives a hollow cylindrical latching member 27 of electrically insulating material. The end of the latching member 27 which engages the base of the  
20 cavity 26 is provided with a conical recess 28 against the surface of which the end of the dielectric layer of an incoming coaxial cable to the connector will abut, as will later be apparent. The right-hand end of the latching member 27 is provided with a radially inwardly extending lip  
25 or projection 29 and, although in the present embodiment the latching member 27 is rendered radially resilient by the provision of slots 30, it should be understood that this may not be necessary, as will hereinafter become apparent.

The latching member 27 is adapted to receive the end  
30 of a split radially compressible metal clamping collet 31 which, in the present embodiment is formed integrally with a contact 32 (e.g. pin contact) of the connector connected to the collet 31 by a split conical section 33. The internal periphery of the clamping collet may be threaded or  
35 provided with serrations or surface irregularities or otherwise configured in order to bite into the outer surface of the single or stranded central conductor of the coaxial

cable during a conductor clamping operation. In the present embodiment the metal clamping collet 31, as can best be seen from Figure 1a of the drawings, is split axially by means of four radial slots 34 which define a cruciform passageway extending axially through the collet and providing four axially extending sharp corners or edges 34a towards the centre of the passageway where clamping of central conductor 44 takes place. The width of the radial slots 34 will be less than the diameter of the central conductor but the central passage or region of the cruciform passageway will be sufficiently large to slidably receive the central conductor 44 before radial compression of the collet 31 takes place to effect clamping of the conductor. During such conductor clamping the axially extending sharp edges 34a of the collet 31 will bite into the conductor 44 in order to ensure good electrical contact therewith. As will readily be apparent, other multi-slot collet constructions could alternatively be provided to achieve a similar result. A six slot collet construction is also especially contemplated.

A resilient split metal ring 35 is provided for co-operating with the collet 31 to effect radial compression thereof to effect clamping engagement with the central conductor 44 (Figure 1a). To achieve such compression, a tubular axially-displaceable member 36 of insulating material is provided. The displaceable member 36 is slidably received in a through bore 37 of the connector body part 23 and when the two body parts 22 and 23 are secured together with the collet 31 and the co-operating split clamping ring 35 located within the internal cylindrical cavity of the body structure, the member 36 can readily be displaced axially simply by exerting pressure on the right-hand end thereof, as viewed in the drawing, so that the radially flexible slotted end of the member 36 defined by slots 38 first makes snap engagement with the tubular latching member 27 by the engagement of the lip or projection 29 on the member 27 with an external

circumferential groove 29 in the slotted end of the displaceable member 36. It will be appreciated that with the latching member 27 slotted, as shown, the slots 38 in the member 36 could be dispensed with. As will readily be appreciated from Figure 2 of the drawings which shows a connector very similar to the exploded connector of Figure 1 but in an assembled state prior to clamping of the central cable conductor, component parts of the connector are securely held in situ by the initial latching arrangement provided between the members 27 and 36. Such an arrangement importantly enables connectors to be handled and/or transported/delivered in readiness for cable connection and conductor clamping without the risk of connector parts becoming detached or lost.

In order to connect the assembled connector to a coaxial cable, as shown at 40 in Figure 3a of the drawings, the usual outer insulation sleeve 41 will be cut back, as shown, to expose a suitable length of an underlying metal braided screen 42. The metal braid will then be stripped back, as shown, over a requisite length to leave a length of extruded dielectric insulation 43 exposed. This dielectric will then be cut back to leave a length of bared central conductor 44. The cable end will then be inserted through a metal crimping ferrule, shown at 45 in Figures 1 and 3b, and then into the cable receiving end of the body part 22 which is already screwed to the body part 23 in the pre-conductor clamping assembled state of the connector. The body part 22 has a tubular extension 46 which may have circumferential ridges 47 so that as the cable moves into the interior of the connector the ridged extension 46 will be urged between the dielectric layer 43 and the metal braiding sleeve 42 of the cable, as shown in Figure 3b, whilst the bared end 44 of the central conductor will move into and along the central passage of the clamping collet 31 as indicated in Figure 1a of the drawings, until the forward end of the exposed dielectric material 43 abuts against the conical surface of the recess 28 provided in the latching

member 27.

To effect clamping of the collet 21 to the central conductor 44 of the incoming cable 40, the axially displaceable member 36 is simply pressed from its initial pre-clamping latched position further into the bore 37, as  
5 a result of which the split clamping ring 35 will be forced by the displacement member 36 over the cylindrical surface of the split collet 31 which is accordingly compressed radially inwards so that the inner axially extending sharp  
10 edges 34a, as shown in Figure 1a, bite into the outer surface of the single or stranded central conductor in order to make good electrical contact therewith. When sufficient clamping force has been exerted on the collet 31 by movement of the clamping ring 35, the displaceable member 36  
15 makes a second and final snap engagement with the latching member 27 by the engagement of a second circumferential groove 48 in the member 36 with the inturned lip or projection 29 on the latching member 27. In this position of the displaceable member 36 the components of the  
20 connector are in the conductor clamped assembled state and the resilient split clamping ring 35 co-operates with the collet 31 to provide an ongoing pressure engagement between the collet and the central conductor 44 without the need for a continuing axially applied force to the ring 35. In this  
25 state of the connector the cable may be pulled to carry out a tensile test for ensuring that effective clamping of the central conductor has been achieved.

It is contemplated that the members 27 and 36 could be composed of a transparent insulating material which would  
30 enable a conductor clamp connection to be viewed after unscrewing the two body parts 22 and 23.

Although in the embodiments described with reference to Figures 1 to 4 the sleeve member 35 comprises a resilient split ring 35 which co-operates with the clamping element 31  
35 to provide ongoing pressure engagement with the central conductor 44 it will be appreciated, as already mentioned, that the resilient sleeve member 35 could be replaced by a

non-resilient sleeve member which co-operates with resilient contact-making means over which the sleeve member fits to provide the ongoing pressure engagement between the contact-making means and the central conductor of the coaxial cable.

5           As will be apparent, once the resilient or non-resilient sleeve member has been moved over the contact-making means the insulating displacement member and other parts of the connector could be removed without unclamping of the central conductor.

10           In order to complete the strain relief connection between the incoming cable 40 and the connector, the metal ferrule 45 may be positioned over the metal braiding overlying the tubular ridged extension 46, as can be seen in Figure 1 of the drawings, and then crimped down on to the  
15 braiding, as shown in Figure 3c.

To enable the connector to be panel mounted, a radially collapsible ring 49 may be fitted in a groove of the body part 23. The configuration of the ring allows the contact end of the connector to be inserted into a panel  
20 aperture after which the ring restores to hold the connector in position.

Referring finally to Figure 4 of the drawings this shows a coaxial cable connector which is identical to that shown in Figure 3 apart from the cable strain relief  
25 arrangement.

After suitable stripping back of the outer insulation sleeve 41 and braiding 42 of the cable 40, as shown the stepped tubular extension 46 will be forced between and effect separation of the inner dielectric layer  
30 43 from the braiding 42 so that the separated outer layers of the cable extend over the extension 46. A stepped clamping bush 50 which has radial slots 51 defining resilient arms 52 is then pressed over the extension 46 so that latches 53 at the ends of the arms 52 make snap  
35 engagement with an internal groove 54 provided in the nut 25. In this position of the clamping bush 50, the incoming cable is firmly clamped relative to the connector body

structure to prevent straining of the central conductor 44 which is clamped to the clamping element/contact 32,33.

Although the invention has been specifically described as applied to a coaxial connector it will readily  
5 be apparant that it could be applied to single or multi-way non-coaxial connectors.

## CLAIMS:

1. An electrical connector comprising a tubular body structure having an axially extending bore therein for receiving an incoming cable and for accommodating electrically-conductive contact-making means located adjacent a part of the cable within the tubular body structure and electrically coupled with contact means (e.g. pin contact) of the connector, and axially displaceable means at least partly received by the tubular body structure and effective to cause the contact-making means to make good electrical contact with a conductor of the cable in response to a predetermined axial displacement of the displaceable means, in which the displaceable means has at least one positive hold position relative to the tubular body structure in which position the displaceable means acts solely to retain other connector components within the tubular body structure and in which the predetermined axial displacement of the displaceable means from the positive hold position to a further position establishes good electrical contact between the contact-making means and the conductor of the cable.

2. A connector as claimed in claim 1, in which the further position of the displaceable means is a positive hold position.

3. A connector as claimed in claim 1 or claim 2, in which the or each positive hold position is provided by co-operating projection(s) and groove(s) formed in the axially displaceable means and another connector component part and making snap engagement with one another in the positive hold position.

4. A connector as claimed in claim 3, in which another connector component part comprises a tubular latching member accommodated in the bore of the tubular body structure.

5. A connector as claimed in claim 4, in which the latching member is slotted to provide a plurality of



radially deflectable arms having a groove or projection thereon for making snap engagement with spaced projections or grooves on the axially displaceable means.

5 6. A connector as claimed in any preceding claim,  
in which the axially displaceable means is arranged to exert  
a radially inward force on a contact-making element of the  
contact-making means to make good electrical contact with  
the conductor of the cable in response to the aforesaid  
predetermined axial displacement of the axially displaceable  
10 means.

7. A connector as claimed in any preceding claim, in  
which the contact-making element comprises a compressible  
clamping element adapted to fit over a bared part of the  
conductor within the tubular body structure of the connector  
15 and electrically coupled with the contact means of the  
connector, the axially displaceable means in response to  
predetermined movement thereof exerts a radially-inward  
compressive force on the clamping element to cause it to  
clamp down on to the conductor.

20 8. A connector as claimed in claim 7, in which the  
compressible clamping element comprises a split tubular  
metal part into one end of which the bared part of the  
conductor extends.

9. A connector as claimed in claim 8, in which the  
25 clamping element is formed integrally with the contact means  
(e.g. pin contact ) of the connector.

10. A connector as claimed in claim 7, 8 or 9, in  
which the actual conductor clamping region of the  
compressible clamping element is screw threaded or otherwise  
30 configured to bite into the outer surface of the conductor  
as clamping takes place.

11. A connector as claimed in any of claims 7 to  
10, in which the compressible clamping element is provided  
with radial slots (e.g. four or six) which have a width less  
35 than the diameter of the central diameter and which present  
at the periphery of a central passage in the element for  
slidingly receiving the conductor, sharp edges to bite into

the outer surface of the conductor when the clamping element is compressed.

12. A connector as claimed in claim 7, in which the compressible clamping element is stepped on its inner  
5 surface to accommodate conductors of different diameters.

13. A connector as claimed in any of claims 7 to 12, in which the displaceable means includes a resilient sleeve member which initially progressively envelops a split clamping element compressing it radially inwards in response  
10 to axial displacement of the displaceable means towards the rear of the connector from the first positive hold position of the displaceable means.

14. A connector as claimed in claim 13, in which the resilient sleeve member is provided by a split metal  
15 ring or a sleeve of resilient material (e.g. plastics material).

15. A connector as claimed in claim 14, in which the resilient sleeve is engaged by or attached to a tubular insulating member of the displaceable means which is  
20 slidably mounted in the bore of the tubular body structure at the contact end of the connector.

16. A connector as claimed in any of claims 7 to 12, in which the axially displaceable means includes a rigid or non-resilient sleeve member which is engaged by or  
25 attached to a tubular insulating member slidably mounted in the bore of the tubular body structure at the contact end of the connector and which moves over resilient contact-making means in order to exert thereon an inward pressure to cause the resilient contact-making means to make continuing  
30 pressure engagement with the conductor of the cable.

17. A coaxial connector constructed in accordance with any preceding claim in which the conductor with which the contact making means makes good electrical contact is the central conductor of an incoming coaxial cable.

35 18. A coaxial connector substantially as hereinbefore described with reference to the accompanying drawings.

Relevant Technical fields

- (i) UK Cl (Edition L ) H2E (ECBB EEGA EEGB EEGE EEGX  
 EEH)  
 (ii) Int Cl (Edition 5 ) H01R

Search Examiner

F J FEE

Databases (see over)

(i) UK Patent Office

(ii)

Date of Search

25 FEBRUARY 1993

Documents considered relevant following a search in respect of claims 1 TO 18

Category (see over)	Identity of document and relevant passages	Relevant to claim(s)
Y	GB 0531947 (CARR) connector is not enclosed by a body, but such is expected from the disclosure of the EP document	1, 2, 6, 7, 9, 11
X Y	EP 0116760 A1 (OMNI SPECTRA)	X: 1, 2, 6, 7, 10 Y: 1, 2, 6, 7, 9, 11

Category	Identity of document and relevant passages	Relevant to claim(s)

**Categories of documents**

X: Document indicating lack of novelty or of inventive step.

Y: Document indicating lack of inventive step if combined with one or more other documents of the same category.

A: Document indicating technological background and/or state of the art.

P: Document published on or after the declared priority date but before the filing date of the present application.

E: Patent document published on or after, but with priority date earlier than, the filing date of the present application.

&: Member of the same patent family, corresponding document.

**Databases:** The UK Patent Office database comprises classified collections of GB, EP, WO and US patent specifications as outlined periodically in the Official Journal (Patents). The on-line databases considered for search are also listed periodically in the Official Journal (Patents).