

J. C. HOYT.
 BATH CABINET.
 APPLICATION FILED APR. 14, 1909.

959,743.

Patented May 31, 1910.

2 SHEETS—SHEET 1.

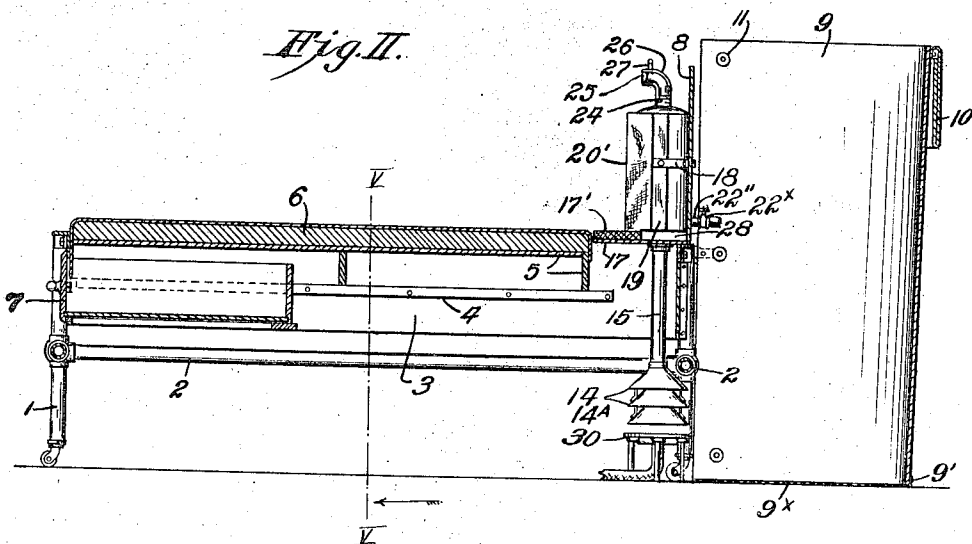
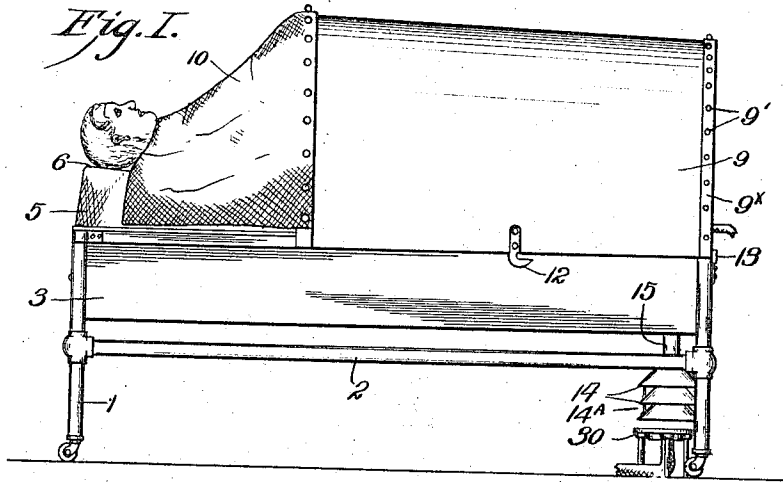

Witnesses.

E. Cahill.
K. W. Dubodan

Inventor.
John C. Hoyt.
 By *Arthur L. Brown.*
 Attorney.

J. C. HOYT.
BATH CABINET.

APPLICATION FILED APR. 14, 1909.

959,743.

Patented May 31, 1910.

2 SHEETS—SHEET 2.

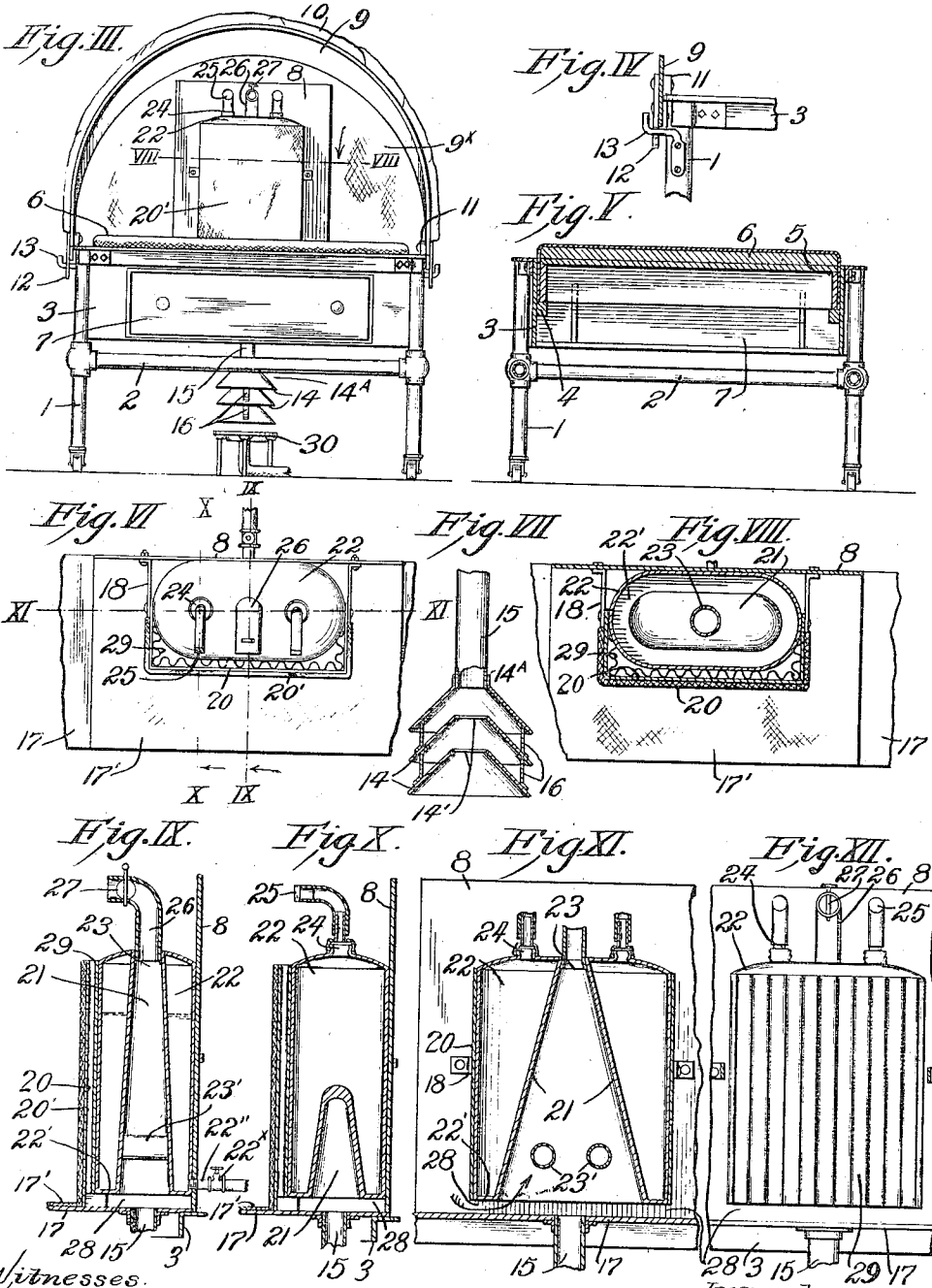

Witnesses.
E. A. Cahill.
H. M. Imboden

Inventor,
John C. Hoyt.
By *Arthur C. Brown*
Attorney.

UNITED STATES PATENT OFFICE.

JOHN C. HOYT, OF KANSAS CITY, MISSOURI.

BATH-CABINET.

959,743.

Specification of Letters Patent. Patented May 31, 1910.

Application filed April 14, 1909. Serial No. 489,878.

To all whom it may concern:

Be it known that I, JOHN C. HOYT, a citizen of the United States, residing at Kansas City, in the county of Jackson and State of Missouri, have invented certain new and useful Improvements in Bath-Cabinets; and I do declare the following to be a full, clear, and exact description of the invention, such as will enable others skilled in the art to which it appertains to make and use the same, reference being had to the accompanying drawings, and to the figures of reference marked thereon, which form a part of this specification.

My invention relates to a combined hot air and steam bath cabinet, and has for its object to provide an apparatus of this class for the treatment of persons by artificial stimulation of the skin to eliminate impurities.

A further object is to provide an apparatus of the class mentioned, wherein free air shall be purified before its entrance into the cabinet; and a further object is to provide means for purifying the air which has received the impurities exhaled by the body.

These objects are attained by the construction herein described and illustrated in the accompanying drawings, which show a preferred but not the sole embodiment of the invention.

In the said drawings;—Figure I is a side elevation of a closed cabinet constructed according to my invention. Fig. II shows the heating apparatus in elevation, the bed in vertical longitudinal section, and the cabinet cover removed, in section. Fig. III is an end elevation looking toward the foot of the cabinet. Fig. IV is a detail view of one of the cabinet cover pivots. Fig. V is a transverse vertical section taken on line V—V of Fig. II. Fig. VI is a top plan view of the generator. Fig. VII is a central vertical section of the air induction device. Fig. VIII is a horizontal section of said generator near the top thereof. Fig. IX is a transverse vertical section on line IX—IX of Fig. VI. Fig. X is a similar section on lines X—X of Fig. VI. Fig. XI is a vertical section of the generator, on line XI—XI of Fig. VI. Fig. XII is an elevational view of the corrugated inter-wall of the generator drum, the outer wall being removed.

1, 2 designates the main frame, comprising the leg standards 1 and the connecting bars

2. Mounted within this frame is a rectangular stationary frame 3, made of either wood or metal. Mounted revolubly on strips 4, within the frame 3, is a mattress frame 5, holding a mattress 6. The mattress frame may be canted as shown in Fig. I, for the comfort of the patient, its upper end resting on the head rail of the bed frame. Frame 3 also contains a drawer 7, which is a convenient receptacle for sheets and for the patient's valuables. Rising from the foot of the frame 3 is an upright plate 8 which supports a metal casing 20.

9 is a cabinet top or cover, made of rigid material and mounted on frame bars 2. Attached to one end of cover 9, by buttons 9' is a depending flap or curtain 9^x that reaches to or below the mattress level. Attached to the opposite edge of the cover 9 is an oilcloth hood 10, adapted to cover the upper part of the patient's body. To facilitate removal of the cover 9 it is provided with antifriction rollers 11, adapted to roll upon the angle-bar edges of outer frame 3. It is also provided with hooks 12 adapted to engage pivot studs 13, secured to the posts 1 as clearly seen in Fig. IV. When the cover 9 is retracted the hooks 12 strike the pivots 13, and the cover is lowered to the floor where it assumes the position shown in Fig. II.

14^A designates an air induction device comprising a plurality of super-posed frusto-conical members 14, the upper of which is secured to an upwardly extending flue 15 that enters the bottom of the generator casing 19. Members 14 are connected together by hangers 16, and have central openings 14'.

17 designates a shelf, forming the bottom of the generator casing 19 and secured to the walls of said casing. Plate 8 forms the back of said casing, and half of the sides is formed by metal plates 18. The remainder of the sides, also the front of the casing, is formed by a sheet metal plate 20, covered externally with asbestos or the like 20', except where its edges lap those of plates 18.

21 designates the fire shell of the steam generator, and 22, the water shell thereof, which latter is provided with a drain pipe 22', having a cock 22^x. The fire shell 22 tapers upwardly to a circular outlet 23. Its bottom is joined to the bottom of the water shell, water tight, by a plate 22'. The bot-

tom of the fire shell 23 is open. Said shell is pierced by two or more water tubes, 23'. Connected into the head of the shell 22 are the steam outlets 24, the upper ends of which are bent forwardly and provided with plugs 25 whereby the discharge of steam into the cabinet may be partially controlled. The hot air outlet pipe 26 is also bent forwardly and is provided with a manually adjustable damper 27. The ledge 17 is covered by a layer of heat-insulating material 17'. The bottom of the generator 21—22 is spaced above the horizontal plate 17, in order to provide lateral air-inlets 28. The upright asbestos covered plate 19 forms a foot-warming plate upon which the patient may place his feet. This plate is reinforced by corrugated sheet metal 29, inserted between the generator body 22 and the front and side walls 20. The top and bottom of said space are open, as shown in Fig. X, thus permitting heated air and gases to ascend freely between the generator and its outer casing.

30 designates a burner, that is adapted to maintain a high flame, and is set directly beneath the flue 15.

The operation of the apparatus is substantially as follows:—Water having been placed in the water shell 22, (as indicated in Fig. IX) fuel is admitted to the burner 30 and ignited. The flame extends well up into the fire shell 21, heating the water therein, while heated air issues into the cabinet through the orifice of tube 26. The patient, preferably stripped, reclines on the mattress 6. The attendant places the cover 9 upon the frame and arranges the hood 10 over the upper part of the patient's body leaving the head uncovered. When the water reaches a sufficient temperature, steam is generated and issues from the orifices of tubes 24 into the cabinet. The therapeutic effects of steam or moist heat upon the skin are well known. Combustion is rendered more perfect by the oxygen of the air that enters flue 15 between the parts 14. The air within the cabinet following the laws of convection and gravity, circulates by entering the lateral openings 28 and issuing from the orifice of tube 26. In so doing it passes through the flame in shell 21, which consumes the impurities which as exhalations from the patient's skin have charged the air.

Any part of a patient's body that may require higher temperature may be elevated above the other parts, as the temperature increases toward the top of the cabinet.

The plate 20 will of course become heated, and some heat will be radiated into the cabinet from this and adjacent metallic parts.

The relative humidity within the cabinet may be varied, also the quantity of hot air issuing from pipe 26 regulated, by adjusting the damper 27.

The length of a treatment will depend, of course, on the judgment of the practitioner or the attendant in the individual case.

Having thus described my invention, what I claim as new therein and desire to secure by Letters-Patent is:—

1. A bath cabinet comprising a supporting frame and a cover adapted to inclose a portion of said frame, and a heating box supported on an inclosed portion of said frame, and adapted to receive heated air and free air from the exterior of the cabinet and circulating air from the interior of the cabinet and for discharging same into the cabinet.

2. A bath cabinet comprising a supporting frame, a canopy adapted for inclosing a portion of said frame, a heating box supported on an inclosed portion of said frame and having openings near the bottom adapted for the intake of circulating air and provided with an upper discharge port, and a common conduit adapted to receive heated air and free air from the exterior of said cabinet and discharge same into said interior heating box.

3. In a bath cabinet, a heating box having a top mouth and lower air ports, a corrugated inner facing on said box beneath said mouth, a hood located within and supported above the base of said box, an outlet on the top of said hood projecting through said box, and means for conducting heated air to said box and hood.

4. In a hot air bath cabinet, a shelf, a heating box seated on said shelf and having lateral intake ports at the bottom and an air discharge port at the top, a corrugated facing on the inner surface of one of the box sides, beneath said discharge port and terminating a short distance above the box bottom, an open bottomed hood supported in said box, with its lower edge above said lateral ports, said hood being tapered inwardly toward the top and provided with an outlet passing through the box top, and a tube passing through said cabinet and adapted for discharge into the bottom of said box beneath said hood.

5. In combination, a cabinet, a steam generator within the cabinet, said generator comprising an open bottomed fire shell and a closed bottomed water shell, an outer casing spaced from said generator and provided near its bottom with an air inlet, communicating with said fire shell, a steam outlet from the generator, into the cabinet, and a depending flame-flue discharging upwardly into said fire shell.

6. In combination, a cabinet, a steam generator within the cabinet, said generator comprising an open bottomed fire shell and a closed bottomed water shell, an outer casing spaced from said generator and provided near its bottom with an air inlet, com-

municating with said fire shell, a steam outlet from the generator, into the cabinet, a regulable hot-air outlet from the fire shell into the cabinet, and a depending flame-flue discharging upwardly into said fire shell.

7. In a bath cabinet, a bed member, a rigid cover member adapted to form a part of the top of the cabinet, when mounted on the bed member, pivot studs projecting laterally from one end of the bed frame, and

members secured to said cover member, adapted to engage said pivot studs whereby said cover may be lowered to the floor during coengagement of said hooks and studs.

In testimony whereof I affix my signature in presence of two witnesses.

JOHN C. HOYT.

Witnesses:

E. A. CAHILL,
ARTHUR C. BROWN.