

G. F. SIMONDS.
CROSS CUT SAW.

No. 269,728.

Patented Dec. 26, 1882.

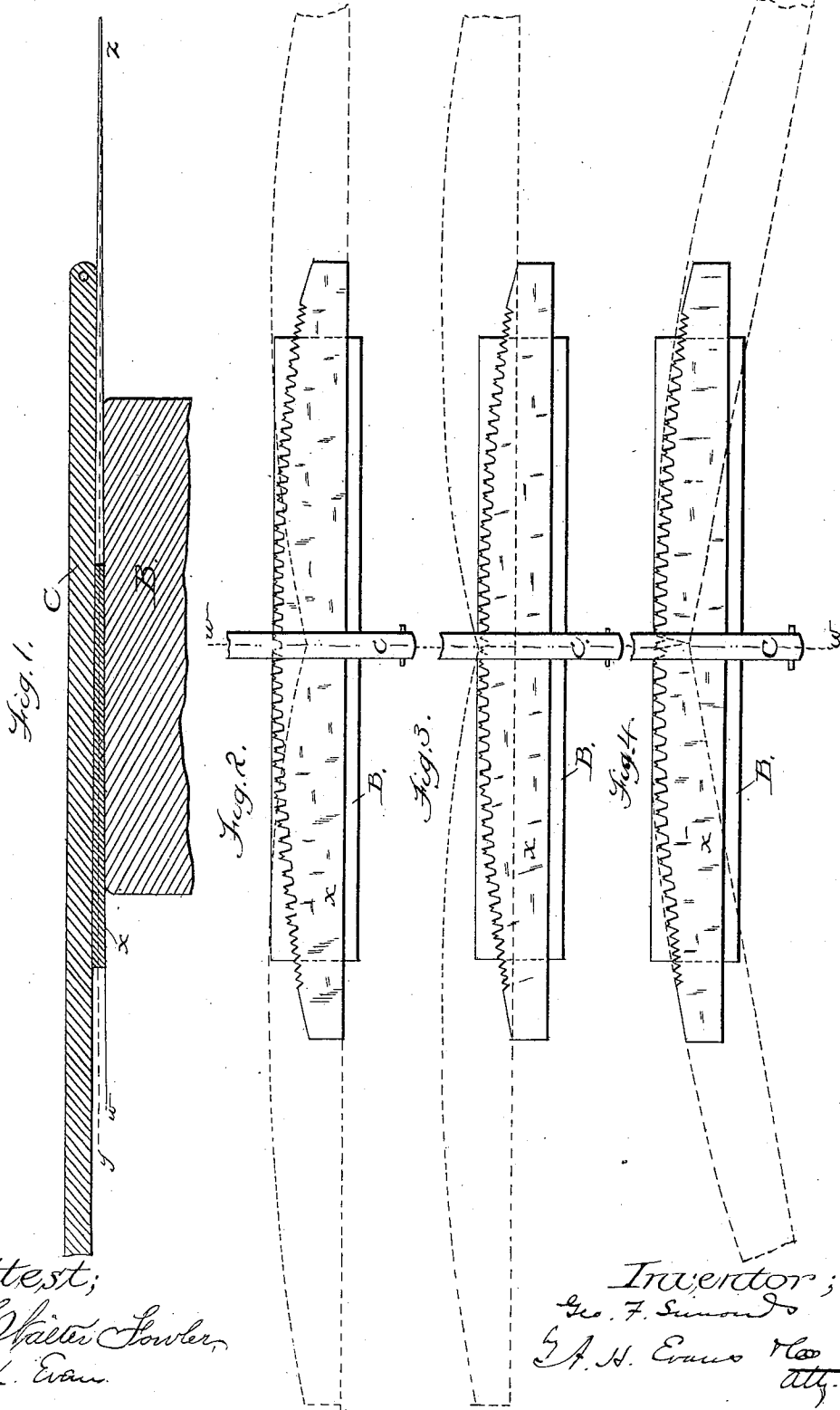

Attest;
T. Walter Fowler,
R. K. Evans

Inventor;
Geo. F. Simonds
G. A. H. Evans *Att.*

G. F. SIMONDS.

CROSS CUT SAW.

No. 269,728.

Patented Dec. 26, 1882.

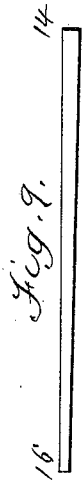
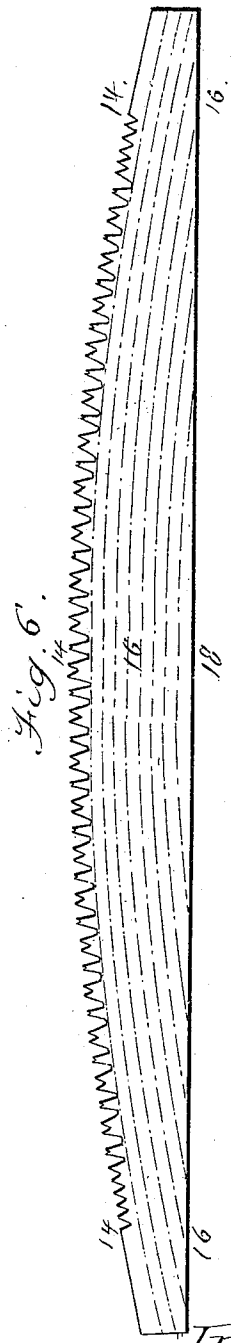
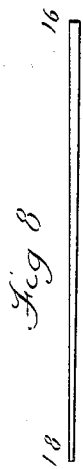
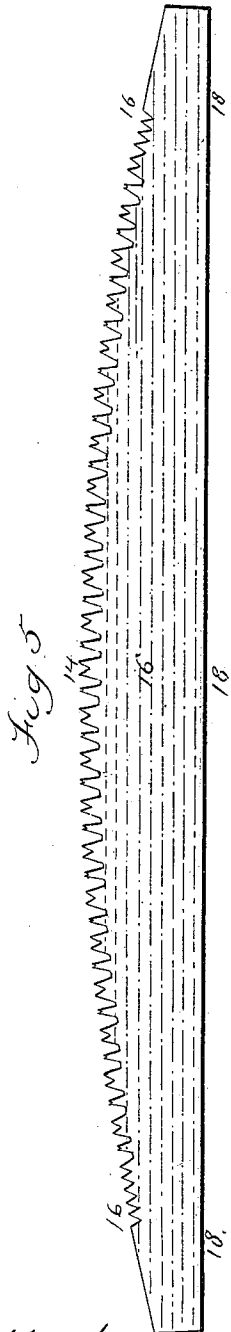

Attest;
J. Walter Fowler,
R. K. Evans

Inventor
Geo. F. Simonds
 by *A. H. Evans* *Att'y*

G. F. SIMONDS.

CROSS CUT SAW.

No. 269,728.

Fig. 10, Patented Dec. 26, 1882.

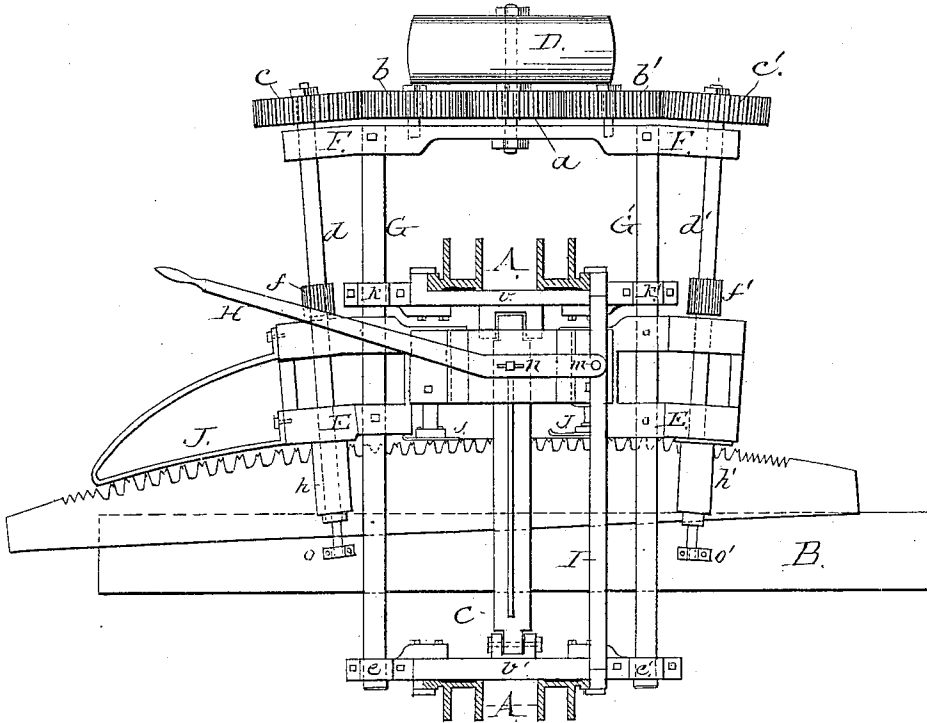
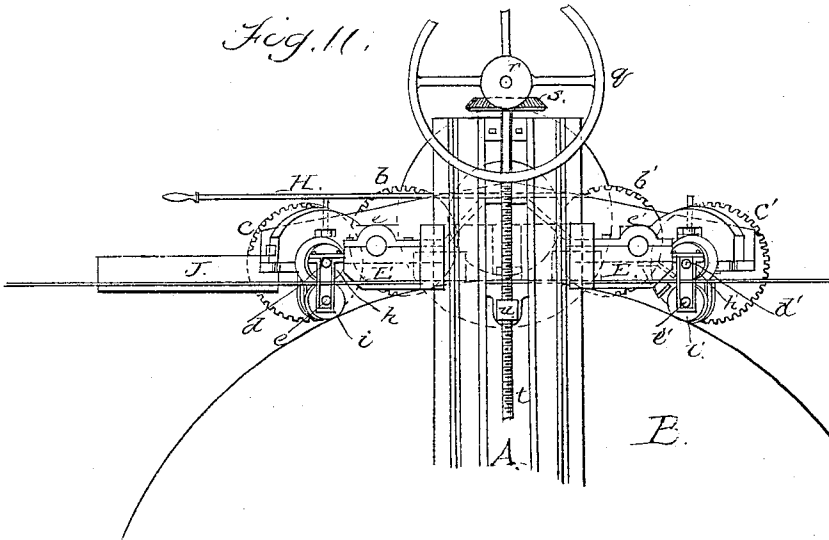

Fig. 11.



Attest;
 Shaler Fowler,
 R. K. Evans.

INVENTOR;
 Geo. F. Simonds
 A. H. Evans Rec.
 Atty

G. F. SIMONDS.

CROSS CUT SAW

No. 269,728.

Patented Dec. 26, 1882.

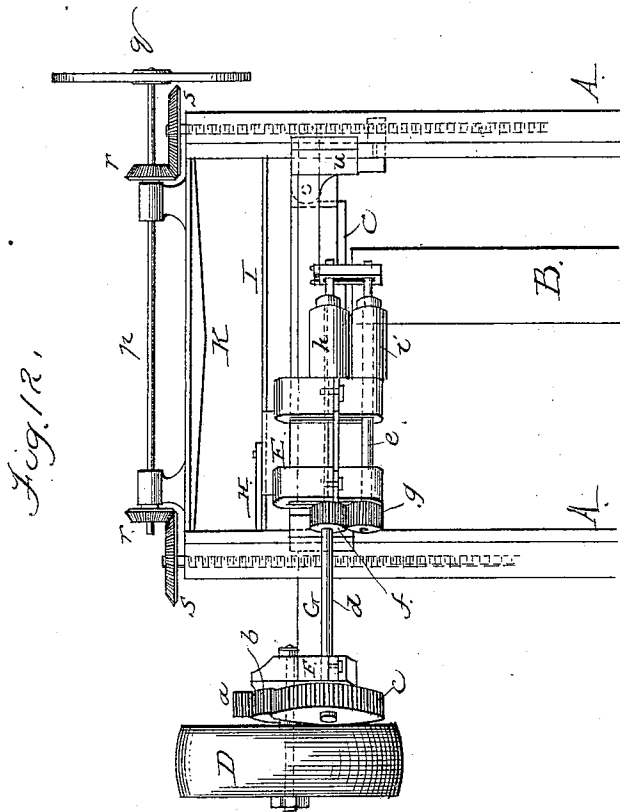

Attest;

J. Walter Fowler,
R. K. Evans.

Inventor;

Geo. F. Simonds
A. H. Evans & Co
Atty

UNITED STATES PATENT OFFICE.

GEORGE F. SIMONDS, OF FITCHBURG, MASSACHUSETTS.

CROSSCUT-SAW.

SPECIFICATION forming part of Letters Patent No. 269,728, dated December 26, 1882.

Application filed October 27, 1882. (No model.)

To all whom it may concern:

Be it known that I, GEORGE F. SIMONDS, of Fitchburg, in the county of Worcester and State of Massachusetts, have invented certain new and useful Improvements in Crosscut-Saws, of which the following is a specification.

My invention has for its object the construction of a thin-back crosscut-saw that shall cut an even kerf throughout its length, that shall not bind in the cut, and that shall be relatively thickened and strengthened toward the ends, whereby more lumber can be cut and with less labor than as heretofore.

My invention consists in a crosscut-saw of substantially uniform thickness throughout the length of its curved cutting-edge, and of gradually-diminishing thickness in the direction of its width from cutting-edge to back.

What is known as a crosscut-saw is usually a long thin plate of steel gradually narrowing in width from its middle toward each end, and having the edge in which the cutting-teeth are formed curvilinear in general contour. As such saws are intended for use in cutting logs and heavy timbers, provision needs to be made for preventing their binding by reason of the closure of the walls of the kerf upon them, especially when the cut has been nearly completed and there is not left enough uncut material to keep the timber from sagging at that place. To compensate for such tendency to be bound in the kerf is the principal object of grinding the saw-plate, by which it is made to taper in thickness from the cutting-edge to the opposite edge or "back," so called, and is thus enabled to be run without binding unless the sagging of the timber proceeds so far as to incline the walls of the kerf to each other at an angle greater than that of the taper given to the saw-plate itself. The mechanical means commonly employed for performing this grinding has been primarily an ordinary grindstone and a presser-bar set across its acting face at an inclination corresponding to the desired taper of the saw-plate. In other words, the presser-bar is located directly over the line of maximum action of the grinder and in a plane at right angles to the direction of the motion of the grinding-surface at that place. Through the angular space thus formed between the grindstone and the presser-bar the saw-plate is passed, with opposite sides pre-

ented alternately to the grinding-surface at each successive passage, and the back edge always toward the converging lines of the angle. In this way the portions of the saw-plate adjacent to the back are first operated upon, and as they become reduced in thickness the back of the saw is made to enter farther in between the presser-bar and the grinder, until the whole plate is brought to a taper in the direction of its width.

The method of grinding crosscut-saws heretofore practiced has been to move them in a rectilinear path from end to end straight across the line of maximum action of the grinder, or substantially perpendicular to the plane which is common to that line and the presser-bar. By this means each plate was ground tapering in thickness transversely from cutting-edge to back at right angles to the straight path of its movement upon the grinder; but while such mode of treatment made the saw-plate better able to escape binding by the inclination of the walls of the kerf it produced defects which created other serious difficulties in the way of practical use, for it will be perceived that as the saw was moved bodily endwise in a rectilinear path through the angular space between the inclined presser-bar and the surface of the grindstone the lines of uniform thickness in the tapered plate would run straight from end to end, and thus the cutting-edge of the saw-plate, by reason of its curvature and the consequent passage of its various portions through spaces of different widths between the presser-bar and the grinder, was made to vary in thickness proportionately to its departure from a straight line; or, in other words, such curvilinear cutting-edge gradually increased in thickness from each end to the middle, and this inequality remained even after setting the teeth of the saw, because it was not feasible to increase the degree of their inclination to the plane of the saw-plate by as much as they decreased in thickness, nor conversely. Hence every such crosscut-saw would cut a wider kerf along its middle than toward either end, and as a practical consequence whenever it was worked with a long stroke one of two undesirable results would follow—namely, either the teeth of the middle portion would bind in the kerf already made by the teeth of the portions located nearer the ends or would not run

at all in the narrower kerf, but would ride over it and be occupied in performing the useless labor of enlarging the same by cutting down its walls. Furthermore, the comparative thinness of the saw-plate at and near its ends rendered it liable to kink or snap there in the attempt's of the workman to force it by pushing.

Before proceeding to describe my improved method of grinding and the new product resulting therefrom, it will aid to a better understanding of the subject to further consider the conditions under which the old method of grinding has taken place, and some of which are still present in the practice of the new method.

Thus far the positions and movements of the saw have been referred to the presser-bar and grinder; and it is evident that in practice some mechanical means must be employed for performing the offices of the presser-bar in holding the saw against the grinder at the proper inclination. For example, crosscut-saws have been ground between two grindstones acting simultaneously on opposite sides of the plate, and in such case the grinding-surfaces, where they come into action, are inclined to each other at an angle corresponding to that of the taper to be given to the saw transversely, and they reciprocally perform each for the other the functions of a presser-bar; but for the purposes of defining the relationship of the saw-plate to the grinding-surface the presser-bar or its equivalent may be left out of account.

It will be readily understood that whether the grinding of the saw proceeds alternately on opposite sides, as with one grindstone, or simultaneously, as with two grindstones, the transversely-tapering plate is substantially bisymmetrical with reference to a geometrical plane passing through the median lines of its edges, or, in other words, that such a plane divides it edgewise into two plates substantially equal and similar each to each. For convenience of description we shall refer to this geometrical plane which symmetrically divides the plate edgewise as the "plane of the saw-plate." Further economy of description may be gained by denoting the line of maximum action of the grinder as simply the "grinding-line," which, in the case of a machine employing a presser-bar, as already explained, would be located at the intersection with the grinding-surface of a plane perpendicular thereto, and at right angles to the direction of motion thereof, passing through the presser-bar longitudinally and centrally—that is to say, through what, for brevity, may be termed the "axis" of the presser-bar; and in the case of two grinders co-operating upon opposite sides of the saw-plate the grinding-line of each would be located at the intersection of the same plane with their respective grinding-surfaces, perpendicular thereto and at right angles to the direction of motion thereof. It should be understood, also, that the term "grinding-line" as here used is intended to signify not merely so much of it as is co-extensive with the actual dimension of the grind-

ing-surface along the line of its maximum action, but also the further geometrical extension thereof in the same direction indefinitely. In case of a grindstone the cylindrical periphery of which acts upon the saw-plate tangentially, the grinding-line is parallel to the axis of the stone, and the plane perpendicular to the grinding-surface, and at right angles to the direction of motion thereof, whose intersection therewith is coincident with the grinding-line, also passes through the axis of the grindstone. It may happen that the periphery of the grinder is slightly convex, so as to grind the transverse taper of the saw-plate a little concave, in which case the actual grinding-line would be somewhat curved; but for the purposes of definition this variation is immaterial, since, whether the angular space between the grindstone and the presser-bar or its equivalent be bounded by converging curves or converging straight lines, the saw-plate, when in proper position therein for grinding, will always have its plane inclined to the grinding-line and its back toward the apex of the angle of inclination.

Instead of moving the saw-plate to the action of the grindstone in a rectilinear path, I give it such movement as to cause every part of its curved cutting-edge, throughout the entire length thereof, to pass successively through the plane which is common to the axis of the presser-bar and the grinding line at substantially the same point during any given passage, so that the lines of uniform thickness in the tapered plate are curves running substantially parallel to the general curvature of the cutting-edge, because by keeping the cutting-edge of the saw-plate where it passes the grinding-line at the same distance from the apex of the angle of inclination of the presser-bar all other portions which pass through any given constant part of the angular space between the presser-bar and the grinder, and which are consequently reduced to uniform thickness, will necessarily be acted upon at the same distance from the point at which the cutting-edge is maintained, and will therefore be located in a curve which conforms to the curvature of the cutting-edge. In accomplishing this movement of the saw-plate, it will be made to describe a curvilinear path varying in form according to the direction taken by its ends while its cutting-edge passes the grinding-line at a constant point. Thus, for example, it may be given a movement which is the resultant of simultaneous lateral and longitudinal movements similar in character to that of which one member of a parallel ruler is capable, the outer edge corresponding to the back of the saw-plate, and in such instance its successive positions will be parallel to one another, while as a whole it will describe a path the curvature of which is the reverse of that of its cutting-edge; but I prefer, as a more convenient way of grinding my improved saw, to move the entire saw-plate in a curvilinear path substantially parallel to the general curv-

ature of its cutting-edge; and to this end I have constructed mechanism for performing the operation automatically, which, together with the method of grinding, has been incorporated in a separate application for a patent, although it is obvious that the requisite movements of the saw-plate between the grinder and the presser-bar might be given by hand, especially with the aid of a gage or stop against which to keep the cutting-edge of the saw-plate to insure its passage across the grinding-line at a fixed point. I am thus enabled not only to give uniform thickness to the cutting-edge of the saw throughout its entire length, but also to make the plate of the utmost strength and stiffness at the ends consistent with their narrower width. To be sure, the direction of the taper in thickness of the saw-plate from cutting-edge to back will vary somewhat, according to the specific way in which my method of grinding is practiced—that is to say, when the parallelism of the successive positions of the saw-plate is maintained, as in the first example given, the taper in thickness will be in directions at right angles to the chord joining the ends of the curve of the cutting-edge; and when the entire saw-plate is moved in a curvilinear path parallel to the curvature of the cutting-edge, as in the second example given, the taper in thickness will be in directions diametrically across the curves along which the grinding takes place, or, in other words, in a direction at any given point of the curvature of the cutting-edge perpendicular to the tangent of the curve at that point; but these differences are immaterial so far as the practical uses of the saw are concerned. All this will more readily appear from the drawings annexed to this specification, and forming part thereof, wherein—

Figure 1 represents in cross-section taken through the grinding-line perpendicular to the direction of motion of the grinding-surface the grindstone and presser-bar of a grinding-machine with a saw-plate between them. B is the grindstone, C the presser-bar, and x the saw. z is the apex of the angle between the presser-bar and the grinder, and yz the line which is coincident with the plane of the saw-plate.

Fig. 2 represents the extreme and middle positions of a saw with relation to the presser-bar and grinder when ground by the old method by moving in a rectilinear path.

Fig. 3 represents the extreme and middle positions of a saw with relation to the presser-bar and grinder when ground according to my new method by a movement similar to that of one member of a parallel ruler.

Fig. 4 represents the extreme and middle positions of a saw with relation to the presser-bar and grinder when ground according to my new method in the way which I prefer.

In each of the Figs. 2, 3, and 4 the broken line $w w'$, running lengthwise of the presser-bar C, indicates the position of the grinding-line.

Fig. 5 represents the flat side of a crosscut-saw, with broken lines indicating the direction in which the grinding proceeded thereon by the old method.

Fig. 6 represents the same side of a crosscut saw, with broken lines indicating the direction in which the grinding has proceeded thereon by my new method.

Fig. 7 shows in cross-section the relative dimensions of a crosscut-saw of ordinary size, taken at its middle, the same being 14 wire gage in thickness at the cutting-edge and 18 wire gage at the back.

Fig. 8 shows the relative thickness of such a crosscut-saw at the ends when ground by the old method, the same being 16 wire gage at the cutting-edge and 18 wire gage at the back.

Fig. 9 shows the relative thickness of such a size of crosscut-saw at the ends when ground by my new method, the same being 14 wire gage at the cutting-edge and 16 wire gage at the back. The wire-gage thicknesses of the two saws in various parts of their length are further indicated in Figs. 5 and 6, respectively.

Fig. 10 represents a plan view of a grinding-machine embracing improvements which I have invented for automatically putting into practice my new method of grinding crosscut-saws; but for the better showing of these parts certain mechanism for adjusting and holding the presser-bar is omitted in this view.

Fig. 11 is an end elevation of the machine, viewed when looking toward the broadside of the grindstone.

Fig. 12 is a side elevation viewed when looking toward the edge of the grindstone and nearest the feed-rolls between which the saw-plate is first introduced.

Like parts of the machine in the different figures are designated by the same letters.

A indicates the upright supports for the feeding and guiding mechanism. B is the grindstone; C, the presser-bar, which holds the saw-plate down upon the stone during the grinding operation; D, the driving-pulley for the feeding-rolls; $a b b' c c'$, a train of gears intermediate between the driving-pulley and the feeding-rolls; $d d'$, shafts of upper feeding-rolls; $e e'$, shafts of lower feeding-rolls; $f g f' g'$, gears upon the shafts of the upper and lower feeding-rolls, respectively, by which they are driven together; $h i$, forward pair of feeding-rolls, which first act upon the saw-plate; $h' i'$, rearward pair of feeding-rolls.

E is a yoke-shaped frame containing the bearings for the shafts of the feeding-rolls, and F is a frame of similar shape, in which the driving-pulley D, the intermediate gears, $a b b' c c'$, and the rear ends of the upper feeding-roll shafts, $d d'$, are hung. The two frames E F are supported upon bars G G', to which they are fastened by set-screws. The bars G G' slide in bearings $k l k' l'$, which are supported by the uprights A, so that by means of the lever H, which has its fulcrum at m in the stationary bar I, and is connected to the yoke E

by a pin, *u*, working in a slot, the two yoke-frames E F, with the feeding-rolls *h i h' i'* and all their driving-gear, may be moved toward and from the grindstone at the will of the operator.

o o' are links which hold together the projecting ends of the shafts of each pair of upper and lower feeding rolls to prevent them from springing apart unduly when the saw-plate is passed between them.

J J J are guides against which the cutting-edge of the saw-plate is made to bear in its progress through the machine, and which cooperate with the feeding-rolls to give to the saw-plate a curvilinear movement substantially conforming to the general curvature of the cutting-edge.

K is a brace connecting the upper ends of the upright portions of the frame of the machine, and supporting the bearings of a shaft, *p*, on which is a hand-wheel, *q*, for regulating the position of the presser-bar C. This shaft *p* has upon it two bevel-gears, *r r'*, which mesh into other bevel-gears, *s s'*, respectively, on the upper ends of screw-rods *t t'*. These latter turn in nuts *u u'*, attached to slides *v v'*, which carry the presser-bar C between them. The end of this presser-bar which is toward the end of the machine opposite to that containing the driving-pulley is jointed to its slide in such manner as to enable it to be set at an inclination with the grinding-surface corresponding to the desired taper of the thickness of the saw-plate.

In machines of this kind heretofore used for grinding crosscut-saws the two sets of feeding-rolls have been parallel to each other and substantially perpendicular to the plane of the grindstone, so that they have always fed the saw-plate over the grinding-surface in a rectilinear path. On the other hand, I have so organized the machine that the two sets of feeding-rolls have their respective axes inclined to each other, so that by their conjoint action upon the saw-plate they will move it in a curvilinear path substantially conforming to the general curvature of the cutting-edge of the saw. To accomplish this result in the best manner, the axes of each set of feeding-rolls should be perpendicular to the tangent of the curve of the path of movement to be given to the saw at the point where such curve passes between the rollers, so that, for instance, in case the curve of the path of movement were an arc of a circle, a plane passing through both axes of either pair of feeding-rolls would cut such arc in the direction of a radius thereto at the point of intersection.

It will be readily understood that in order to have a set of feeding-rolls on each side of the line where the grinder acts they must necessarily be placed far enough apart to enable the lower roller of each pair to lie below the plane which is tangent to the grindstone at its grinding-line, and hence while either end of

the saw-plate is passing across the space intervening between the feeding-rolls on opposite sides of the grinding-line there needs to be, in addition to the single pair of feeding-rolls then acting upon the saw-plate, some auxiliary means for insuring its movement in the required curvilinear path. For this purpose I have provided the stationary guides hereinbefore described with surfaces for the cutting-edge of the saw-plate to bear against, both in front of the forward pair of feeding-rolls and also between those and the rearward pair, so that while either set of feeding-rolls, acting singly, tends to move the plate in a direction at right angles to its axis, such tendency may be constantly curbed and the required curvilinear movement produced by keeping the cutting-edge of the saw-plate against the guides. The same result might be effected by providing an additional pair of feeding-rolls outside of each of those shown and described, and having their respective axes in like manner perpendicular to the tangent of the curve of the path of movement to be given to the saw-plate at the point where it passes between them; but my invention of the new crosscut-saw herein described is not limited by the specific character of the mechanism which may be employed for producing the same, the prime object being to eliminate certain practical defects consequent upon the old method of grinding in straight lines from end to end of the saw-plate; and the advantages of construction begin to be measurably obtained in straight saws as soon as the grinding takes place along curves which begin to approximate to the contour of the general curvature of the cutting-edge of the saw-plate, whatever may be the mechanical means employed for effecting such mode of operation, so that although in order to insure complete uniformity in the thickness of the cutting-edge of the saw-plate the direction of the grinding should perfectly conform to its curvature, yet the saw will be substantially made by any form of such curvilinear grinding as constitutes a material departure from the old way of straight grinding.

The improvements which I have invented in machinery for grinding crosscut-saws according to my improved method of grinding, which I have herein described for the purposes of illustrating my invention herein claimed, I reserve as the subject-matter of an application for a separate patent.

What I claim as my invention is—

As a new article of manufacture, a crosscut-saw of substantially uniform thickness throughout the length of its curved cutting-edge, and of gradually-diminishing thickness in the direction of its width from cutting-edge to back.

GEORGE F. SIMONDS.

Witnesses:

JOHN SIMONDS,
GEO. P. WARD.