

(19)  
(12)

(KR)  
(A)

(51) 。 Int. Cl. <sup>7</sup>  
F16B 5/06

(11)  
(43)

2003 - 0009768  
2003 02 05

(21) 10 - 2001 - 0044384  
(22) 2001 07 24

(71) 231

(72) 3 APT1310 1401

(74)  
:

(54)

, , 가

1

1

1

2 2  
3 1  
4 2  
5 6

< >

10 : 1 11 :  
11a : 12 :  
12a : 13 :  
13a : 20 : 2  
21 : 22 :  
22a : 23 :  
23a : 30 :  
31 : 40 :  
41 : 50 :  
51 : 52 :  
60 : 70 :

, , 가  
, ,  
, ,

, ,  
, ,  
, .

(200) 5 6 (100)

가

가

(11) ; 1 (10) (30) (11a)가

(11) (12) ;

0) (11) (51) (13a) (13a)가 (13) ; (5)

(12) (12a)

, 2 (20) (21) ; (40) (70)가 (22a)

(21) (22) ;

0) (21) (51) (23a) (23a)가 (23) (5)

, 1 (10) 2 (20) 가

1 2 1 , 3 , 2

1

, 4 2

, 2 10 1 , 20

2

1 (11) , (12) , (11)  
(13) , (12) (12a) .  
(11) (11a)가 (30) (11a)

(13) (11)  
(13a)가 (50) (51) (13a) ,

2 (20) 1 (10)  
가 (21) , (23a)가 (22) , 1 (10)  
(23) , (50) (51) (21) (23  
a) (22)  
22a) (22a) (40) (70)가 .

3 (50) (30) 1 (10) (60)  
0) (11)가 (50) 1 (10) (12) , 1 (1  
(11) (51) (51) (13) (13) 1 (10)  
(51) (13) (13a) 가 (50) ,  
(12a), (50) (12) (30) (31),  
(12a), (52) (70) .

4 (40) 2 (20) (60)  
(40) (41) 2 (20)  
(22a) (70) .

60) (10, 20) 가 (50) , (

가 .

(57)

1.

1 (10) (30) (11a)가 (11)  
 ;  
 (11) (12) ;  
 0) (11) (51) (13a) (13a)가 (13) ; (5  
 (12) (12a)

2.

2 (20) (40) (70)가 (22a)  
 (21) ;  
 (21) (22) ;  
 0) (21) (51) (23a) (23a)가 (23) ; (5

3.

1 2 , 1 (10) 2 (20) 가

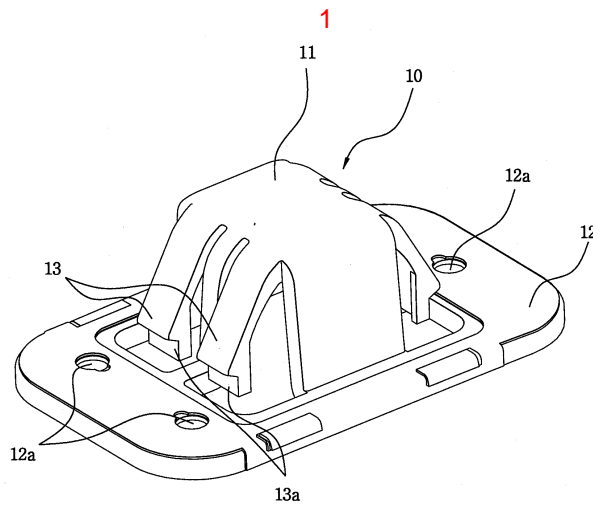

2

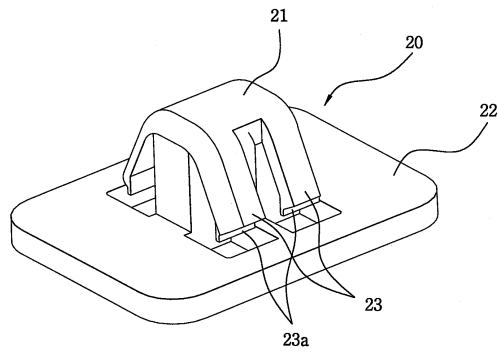

3

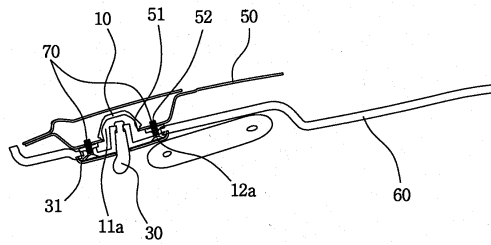

4

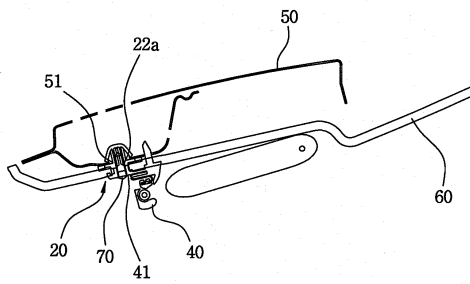

5

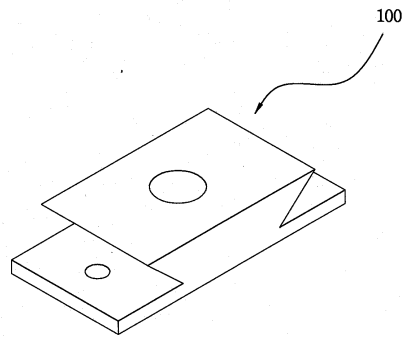

6

