



US00D743757S

(12) **United States Design Patent**
Combs

(10) **Patent No.:** **US D743,757 S**

(45) **Date of Patent:** **** Nov. 24, 2015**

- (54) **BRAKE PAD REMOVAL TOOL**
- (71) Applicant: **Darrell A. Combs**, Aldie, VA (US)
- (72) Inventor: **Darrell A. Combs**, Aldie, VA (US)
- (**) Term: **14 Years**
- (21) Appl. No.: **29/454,374**
- (22) Filed: **May 9, 2013**
- (51) **LOC (10) Cl.** **08-05**
- (52) **U.S. Cl.**
USPC **D8/14**
- (58) **Field of Classification Search**
USPC D8/14, 87, 88, 89; 81/461, 489; 7/166;
29/275; 254/25, 28, 120, 131
See application file for complete search history.

(56) **References Cited**

U.S. PATENT DOCUMENTS

997,986	A	12/1910	Waddell	
2,161,095	A *	6/1939	Schaffer	81/448
3,580,544	A	5/1971	Payne	
4,320,544	A *	3/1982	Bryant et al.	7/158
4,870,737	A	10/1989	Navarro	
D347,370	S *	5/1994	Runevitch	D8/21
D355,103	S *	2/1995	Bartlett	D8/14
D362,898	S *	10/1995	Krupp	D22/149
5,495,651	A *	3/1996	Tsuha	29/235
D428,569	S *	7/2000	Miles	D8/89
6,108,882	A *	8/2000	Hodgson	29/227
6,186,479	B1	2/2001	Witter	
6,460,432	B1 *	10/2002	Julian et al.	81/125.1
6,663,082	B1 *	12/2003	Ploeger	254/21
6,752,380	B1	6/2004	Taylor et al.	
6,883,405	B2	4/2005	Strauch	
6,886,229	B1	5/2005	Wilson	

7,048,255	B2 *	5/2006	Buch et al.	254/28
D540,631	S *	4/2007	Bryant	D8/14
7,232,112	B2 *	6/2007	Foster	254/28
D545,648	S	7/2007	Pulling et al.	
D571,517	S *	6/2008	Zion	D32/49
D594,719	S *	6/2009	Birgl	D8/14
D602,323	S *	10/2009	Alleyne	D8/89
D653,516	S *	2/2012	Li	D8/86
D654,389	S *	2/2012	Gordon	D11/2
D664,019	S *	7/2012	Li	D8/86
2006/0005366	A1	1/2006	Ploeger	
2007/0199189	A1 *	8/2007	Butler	29/242
2012/0279364	A1	11/2012	Baker	

* cited by examiner

Primary Examiner — Phillip S Hyder

(74) *Attorney, Agent, or Firm* — Robert C. Montgomery; Montgomery Patent and Design, LLC

(57) **CLAIM**

The ornamental design for a brake pad removal tool, as shown and described.

DESCRIPTION

FIG. 1 is an isometric view of a brake pad removal tool showing my new design;
 FIG. 2 is a front elevation view of the brake pad removal tool;
 FIG. 3 is a rear elevation view of the brake pad removal tool;
 FIG. 4 is a right side elevation view of the brake pad removal tool, wherein the left side elevation view is a mirror image; and,
 FIG. 5 is a top plan view of the brake pad removal tool, wherein the bottom plan view is a mirror image.
 The broken line showing of the handle is provided for purposes of environment and forms no part of the claimed design.

1 Claim, 4 Drawing Sheets

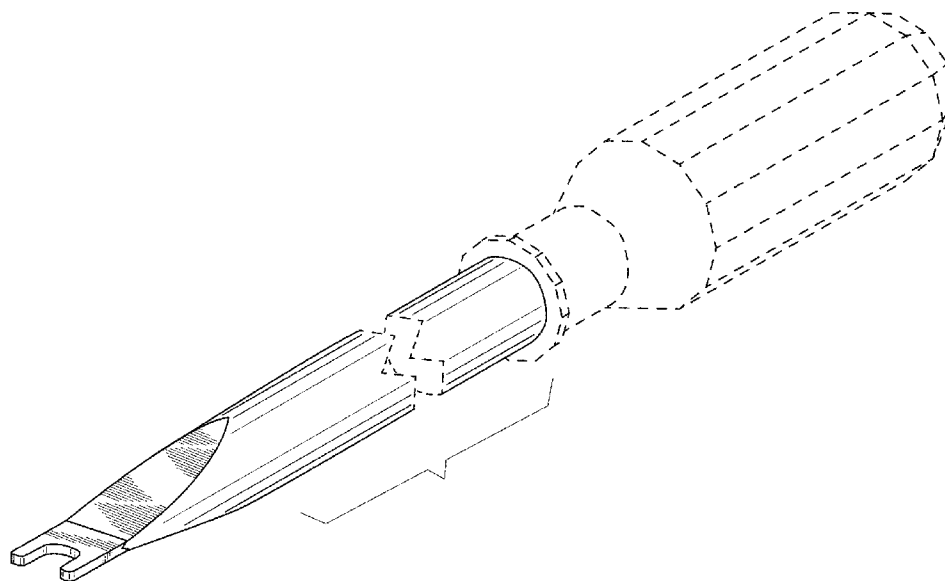

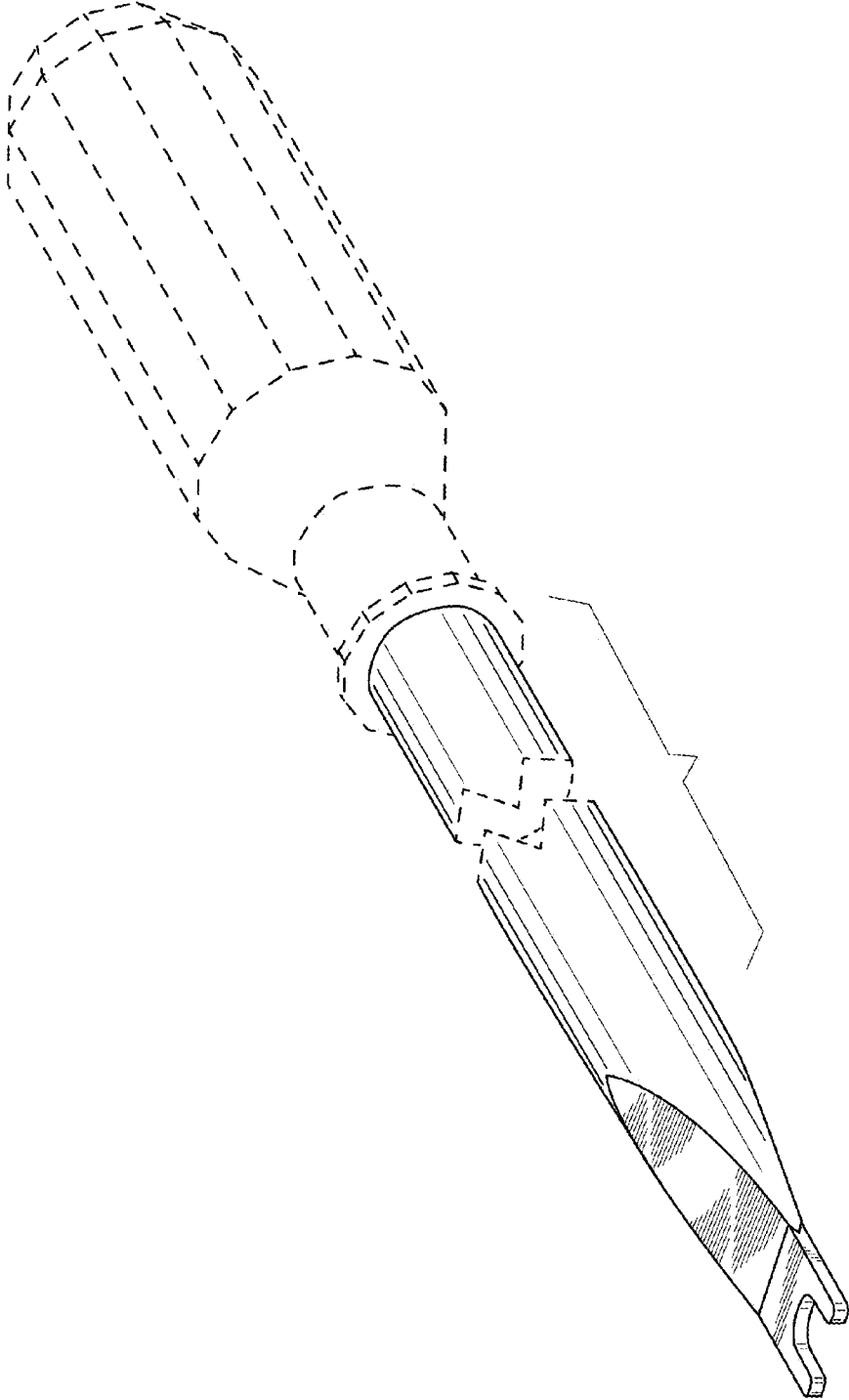

Fig. 1

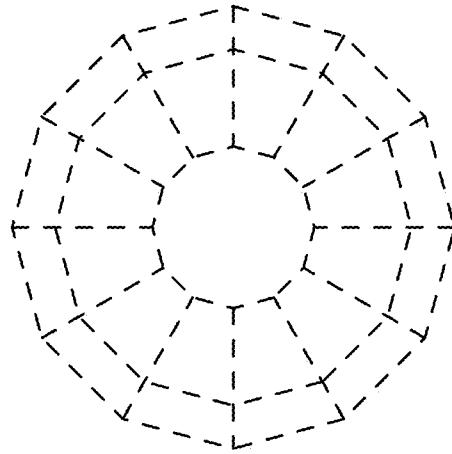

Fig. 3

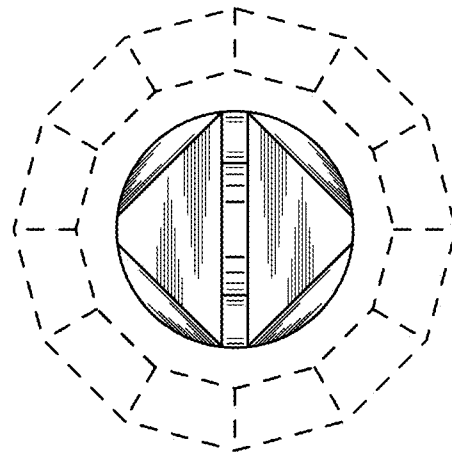

Fig. 2

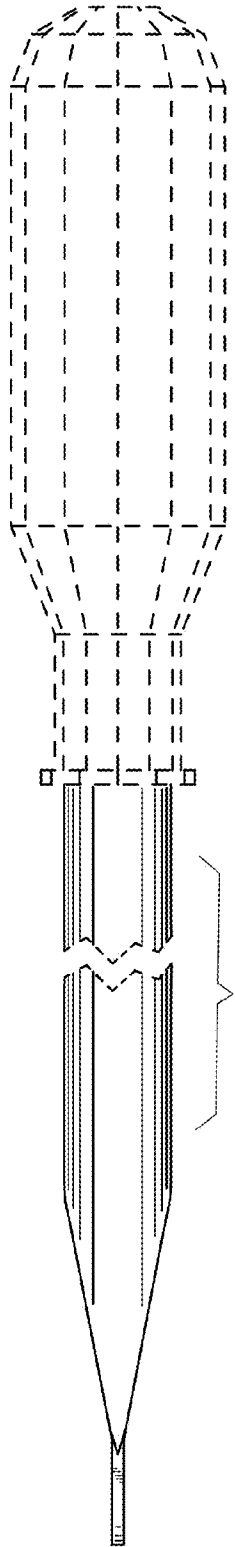

Fig. 4

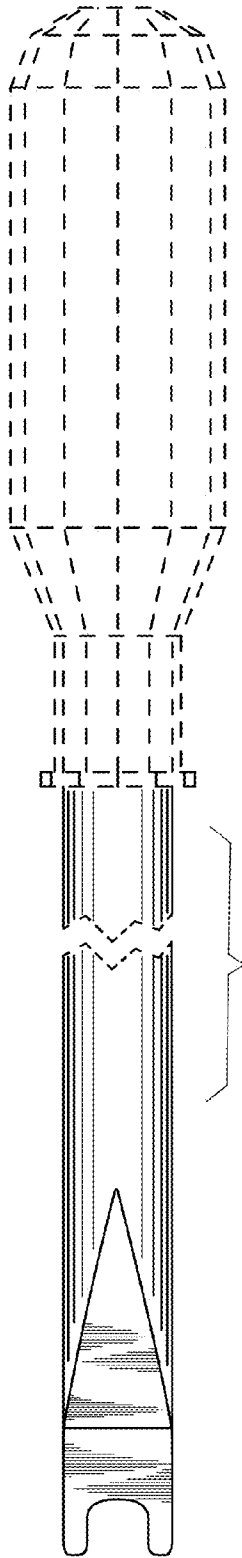

Fig. 5