

(19)
(12)

(KR)
(A)

(51) 。 Int. Cl.7
A61B 1/04

(11)
(43)

10-2004-0013946
2004 02 14

(21) 10-2002-0047097
(22) 2002 08 09

(71) 2 39-1

(72) 39-1KIST A 203

8가 102 403

char.1992 2303

780-3923/3

1 109 405

2-802

(74)

:

(54)

, , ,
,
.

1 1

2 1 가

3 1

4 1 가 가

5a 5b 4

6 1

7 4 가 가

8 7

9 2

10 9 가

11 9

12a 12b 9

13 3

14 13

15 13

16 17 13

100 : S :

101 : 102 :

103 : 111 :

112 : 120 :

200 : 210 :

211 : 1 212 : 2

240 : 214 :

213 : (213) 230 :

231 : 232 :

233 : 234 :

220 : 221 :

222 : 223 :

224 : 410 :
 411 : 420 :
 421 : 500 :
 510 : 511 : 1
 513 : 514 :
 520 : 540 :
 550 : 560 :
 561 : 562 :
 600 : 620 :
 621 : 622 :
 623 : 624 :
 625 : 640 :
 650 : 651 :
 652 :

(臟器)

가

가

(Virtual Colonoscopy)
(生檢;Biopsy)

가 ,

가

(臟器)

(臟器)

가

(臟器)

1 가 , 3 1 가 가 , 2 1 , 5a
 5b , 4 4 1 가 가 , 5a
 (210) , (210) 1 4 (100) ;
 (100) (200) ; (100) (220) (100) (200) (100) (42)
 0) (100) (101) , (101) (102)
 (103) (102) (S) (410) (111) (112) (421), (420), (10)
 1) () (S) (100) () (220)가
 , , , 가
 (100) (120)가 (101) (220) (200) (200)
 (120) (100)
 1 (211) , (210) (120) (120) (220) 1 (211)
 (240) (211) (100) (220)가 2 1 (212) , 2 (212) 1 (211) (211) (420)
 (240) (240) (Shape Memory Alloy) (wire), (Piezo), (

) 1 (211) 2 (212) (240) (214; roller) (

213)가 1 (211) (213) (220)가 (100) (

(214) (220) 3 (120) 1 (211) 가 (

100) (100) (100) (100) (22

0) (100) (220) (210) 1 (211)

, 1 (411) (421) ()가 ,

(421) , 6 (420) (420) (220)

, (220) (230)가 가

4 1 가 가 , 5a 5b

4

31) (230) 4 (220) (231) , (2

(233) 가 (232) , (232) (cup;),

(check valve;) (233)

(234) (231) (232)가

(230) 5a 5b , (220)가

(233)

, (200), (220)

7 4 , 8 7

, (200) (220) 7 8 , 2 (100)

(100)가 (220)

(220) 가 (221) (222) , (221) 가

(225) (222) (223) , (223) (222) (223)

(223) (420) (223) (223) (221)

(224) (224) (226)가 (224)

(230) (223) 8 , (223) 가

(100) , 1 (200)가 (220)
 가 (200)가
 9 가 2 , 10 9
 , 12a 12b 9 , 11 9
 , (500) 9 12a 12b , 2 (100)
 (520)가
 , (510) (100) (550) , (550)
) (511) (520)가 (550) 1 (511) , 1 (511)
 (520)가 (420) 1 (511)
 (540)
 (550) (100) (100)
 (550) (120)
 1 (511) , 1 (513) 가 (520)가
 , 1 (511) (540) (514; roller)
 , 가 2 9
 , (520) (100)
 , (540) , 10 12 , (420) 가 , (420)
 , 2 가 가 가 ,
 , 11 (550) , (560) (500)가 (100) 가
 (100)
 (560) (550) 가 (100)
 (120) , (550)
 (550) (100) (420) (561) , (56)
 (550) (120) (550)
 2) . (560) 12a 12b , (500)가
 (550) (120)
 , (500) (500) 2 (500) ,
 (550) (100) (500)
 13 3 , 14 13 , 16 17
 , 15 13 , 16 17

13

3 1

(600) (620) 13 15 (621) (622) ,
 (621) 가 (622)
 (623) , (621) 가 (622) (621) (622) ,
 24) , (623) (623) (622) (621) (626)
 (625)

(640) (100) (650) ,
 (650) (624) (622) (651) , (622)
 (651) (650) (420)
 (620)가 (651) (652)

3 13
 (420) (100) (652) , 가,
 (652)가 , (620) 가
 (620)가 , (652) (620) (623)
 , (100) . 16 17

(57)

1.
;

;

2.

1

3.

2

가

4.

1 ,

가

5.

4 ,

가

가 가

6.

4 ,

7.

6 ,

8.

4 ,

2

가

가

2

9.

1 4 ,

가 가

10.

9 ,

가

11.

9 ,

가

가

12.

1 4 ,

13. 1 4 ,

가

14. 1 4 ,

가

15. 14 ,

2

16. 1 ,

가

1

2

1
가

1

1

2

17. 16 ,

가 가 가

18. 17 ,

가

19. 1 ,

가

가

가

20.

4 , 16

19

1

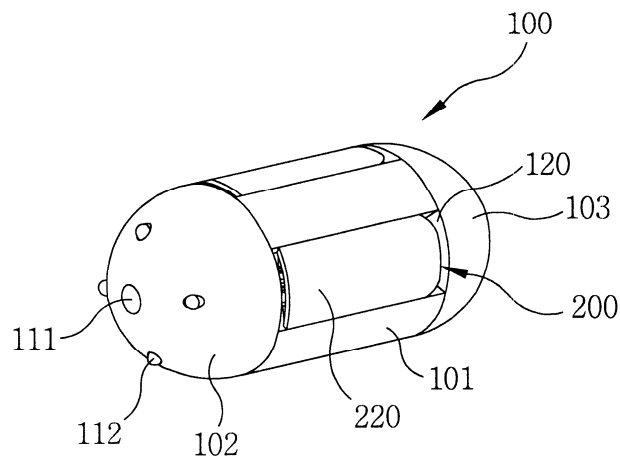

2

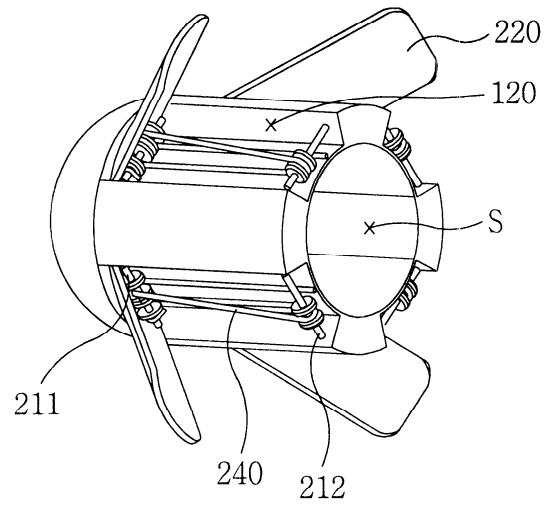

3

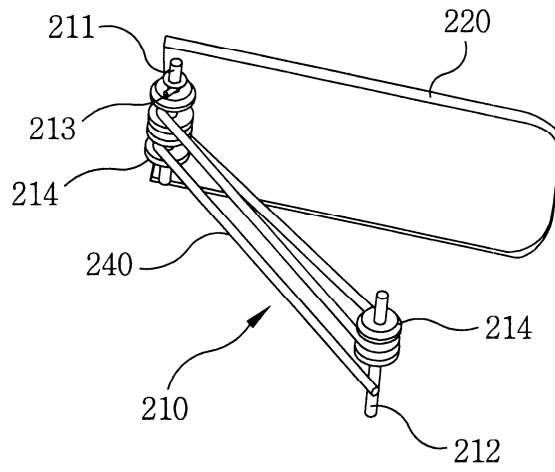

4

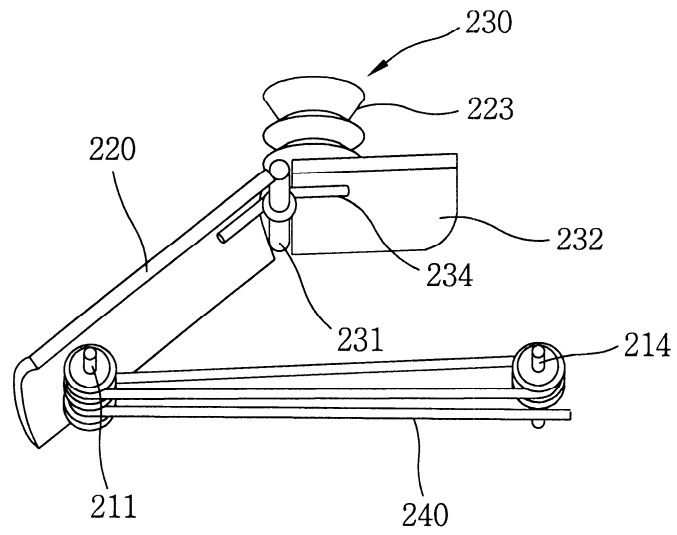

5a

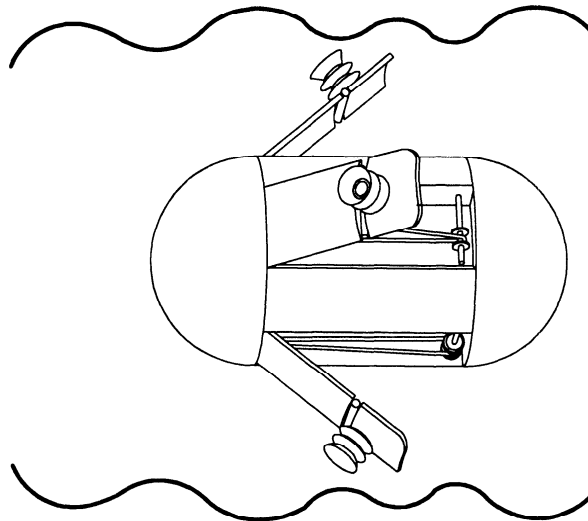

5b

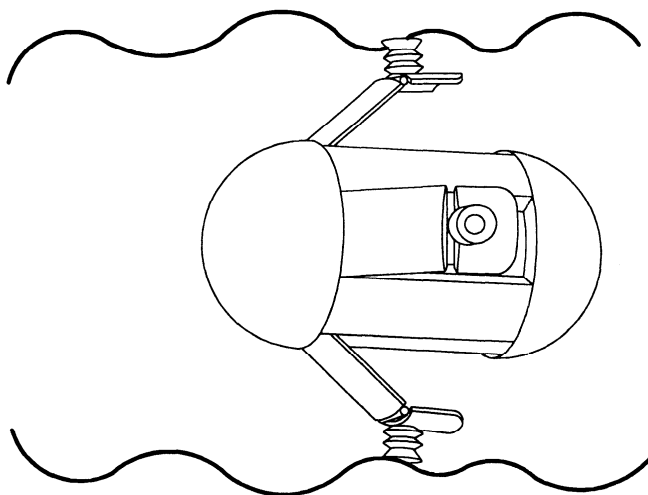

6

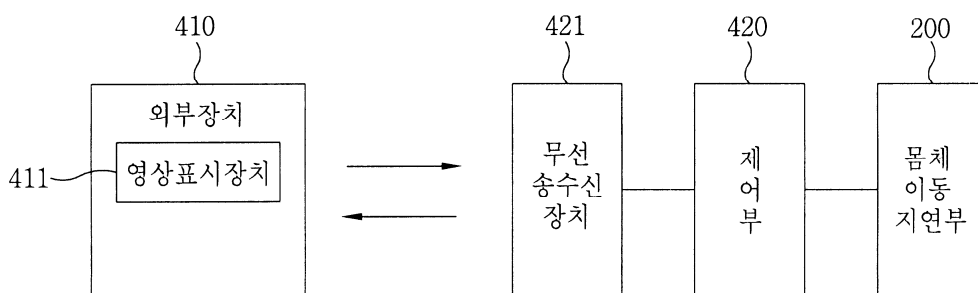

7

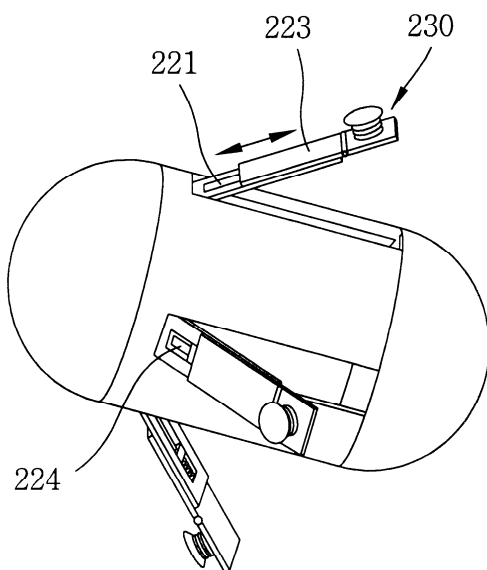

8

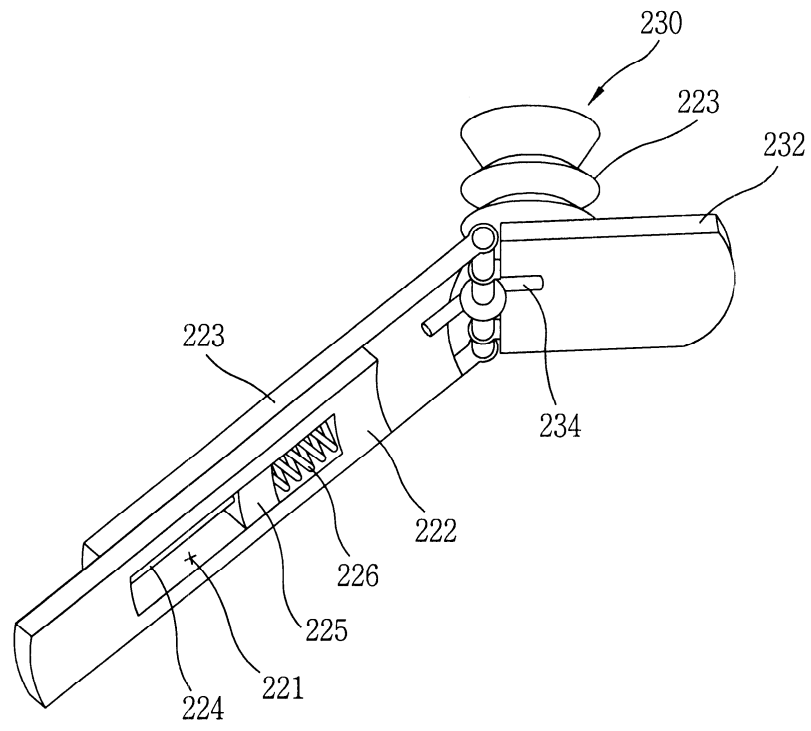

9

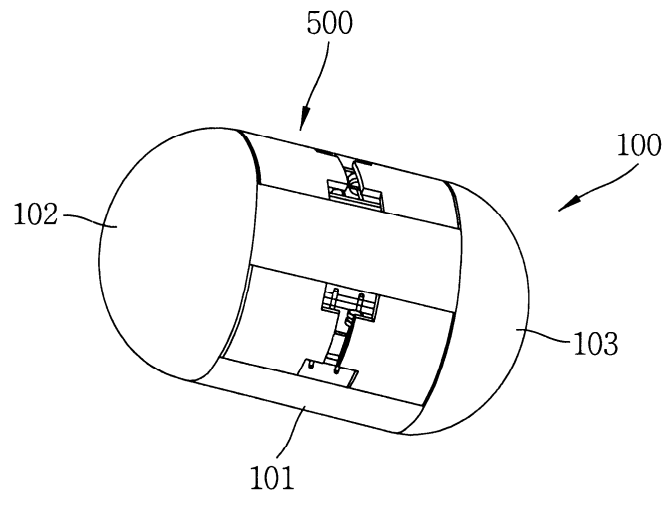

10

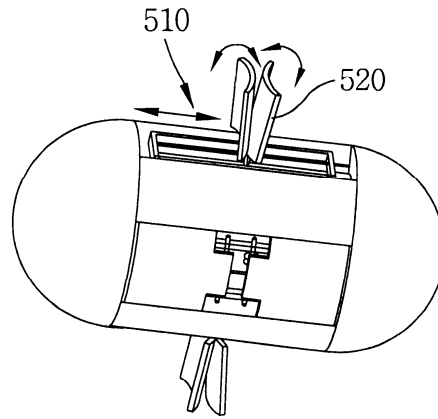

11

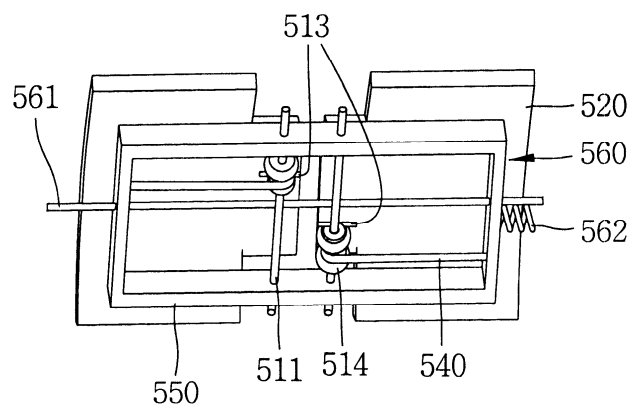

12a

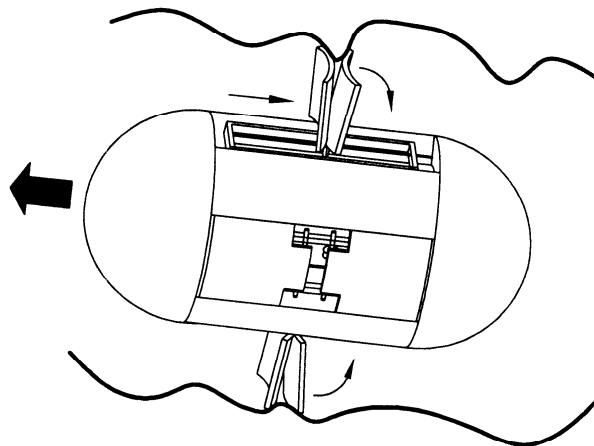

12b

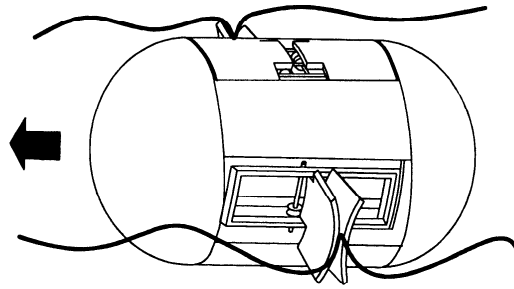

13

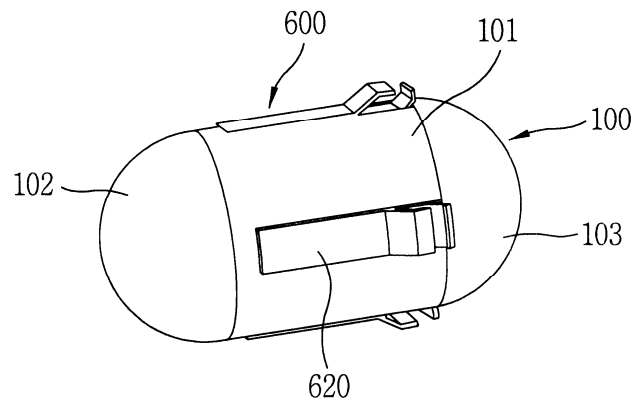

14

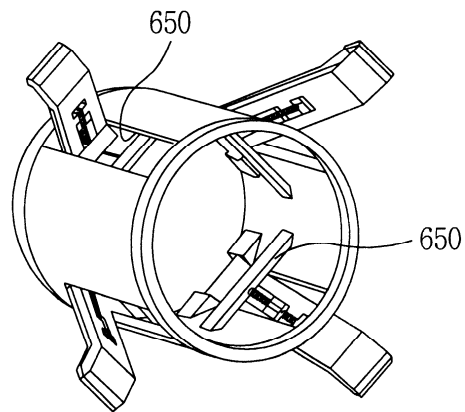

15

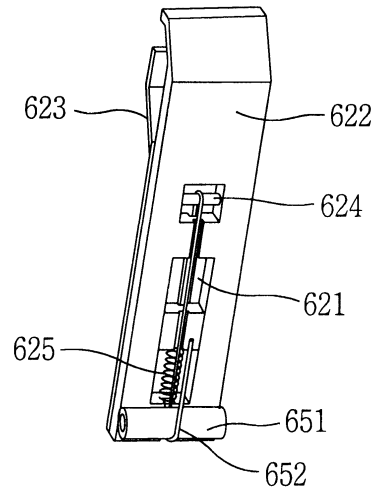

16

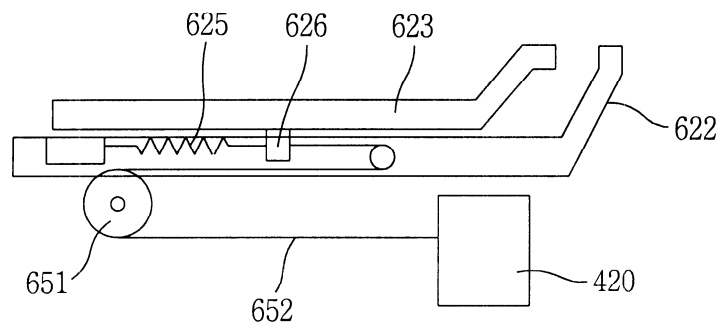

17

