



US 20110002896A1

(19) **United States**  
(12) **Patent Application Publication**  
**KOLODNEY et al.**

(10) **Pub. No.: US 2011/0002896 A1**  
(43) **Pub. Date: Jan. 6, 2011**

(54) **METHODS AND RELATED COMPOSITIONS FOR REDUCTION OF FAT**

continuation-in-part of application No. 11/054,171, filed on Feb. 8, 2005, now Pat. No. 7,622,130.

(75) Inventors: **MICHAEL S. KOLODNEY**,  
Santa Monica, CA (US); **Adam M. Rotunda**,  
Los Angeles, CA (US)

(60) Provisional application No. 60/572,879, filed on May 19, 2004.

**Publication Classification**

Correspondence Address:  
**K&L Gates LLP**  
**1900 MAIN STREET, SUITE 600**  
**IRVINE, CA 92614-7319 (US)**

(51) **Int. Cl.**  
*A61K 35/12* (2006.01)  
*A61K 31/685* (2006.01)  
*A61P 3/04* (2006.01)  
*A61P 35/00* (2006.01)  
*A61P 29/00* (2006.01)

(73) Assignees: **REGENTS OF THE UNIVERSITY OF CALIFORNIA, THE LOS ANGELES BIOMEDICAL RESEARCH INSTITUTE AT HARBOR-UCLA MEDICAL CENTER**

(52) **U.S. Cl.** ..... **424/93.7; 514/78**

(57) **ABSTRACT**

(21) Appl. No.: **12/782,324**

Compositions and methods useful in the reduction of localized fat deposits in patients in need thereof using pharmacologically active detergents are disclosed. The pharmacologically active detergent compositions can additionally include anti-inflammatory agents, analgesics, dispersion or anti-dispersion agents and pharmaceutically acceptable excipients. The pharmacologically active detergent compositions are useful for treating localized accumulations of fat including, for example, lower eyelid fat herniation, lipodystrophy and fat deposits associated with cellulite and do not require surgical procedures such as liposuction.

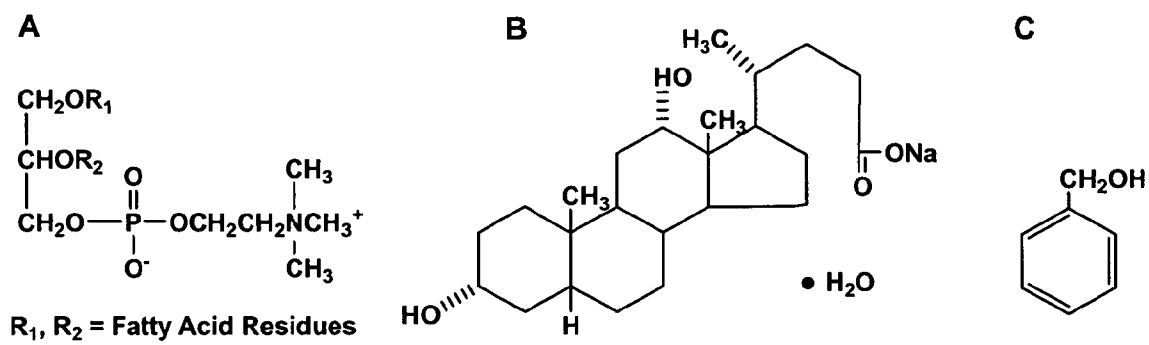
(22) Filed: **May 18, 2010**

**Related U.S. Application Data**

(63) Continuation of application No. 11/134,727, filed on May 19, 2005, now Pat. No. 7,754,230, which is a



FIG. 1



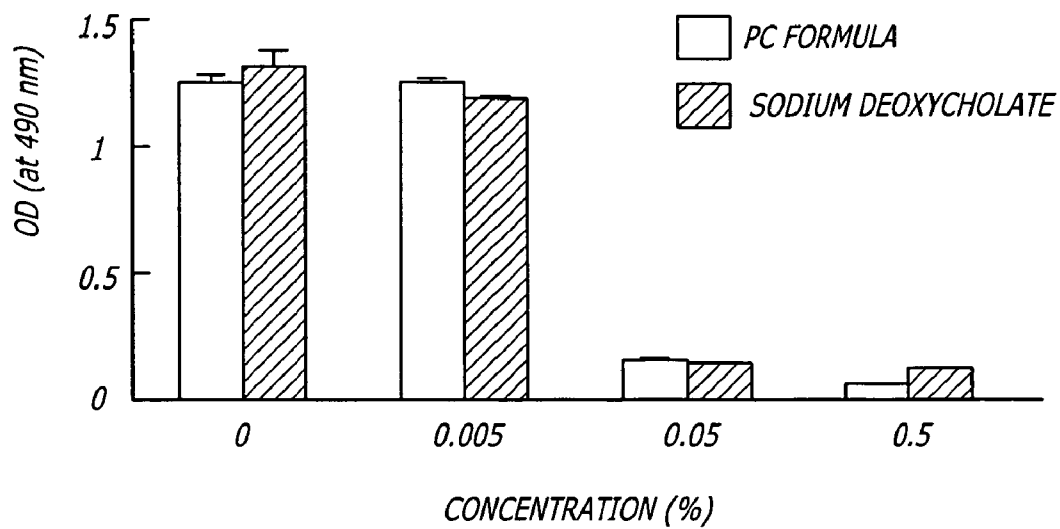


FIG. 2a

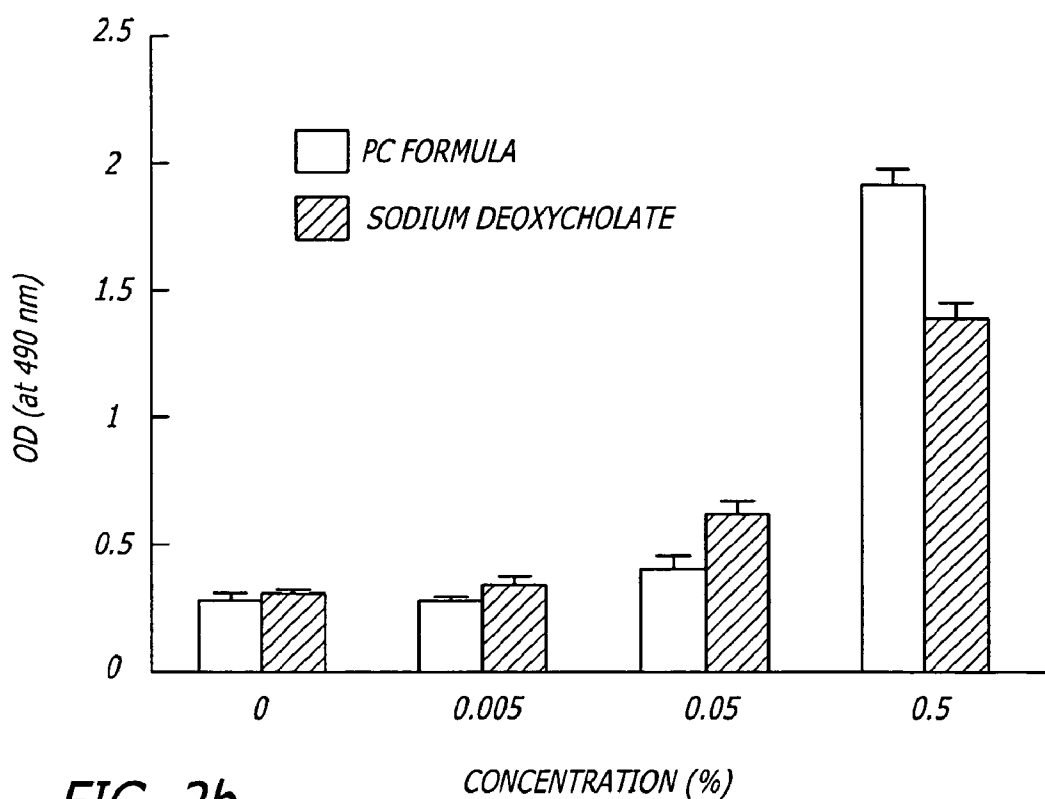
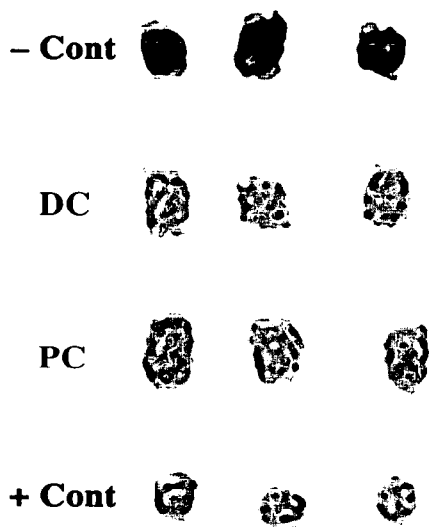
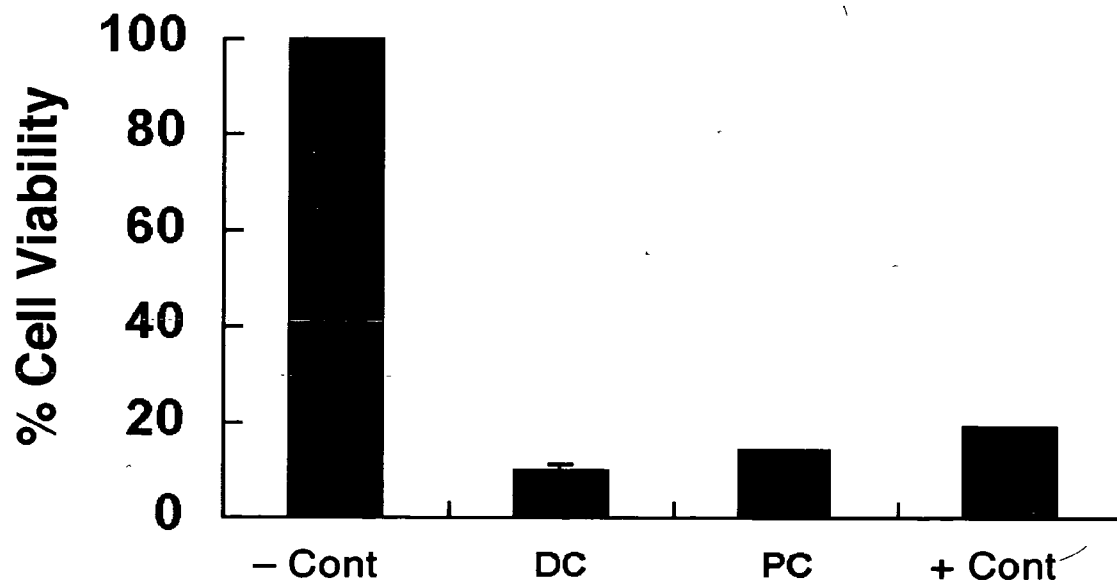


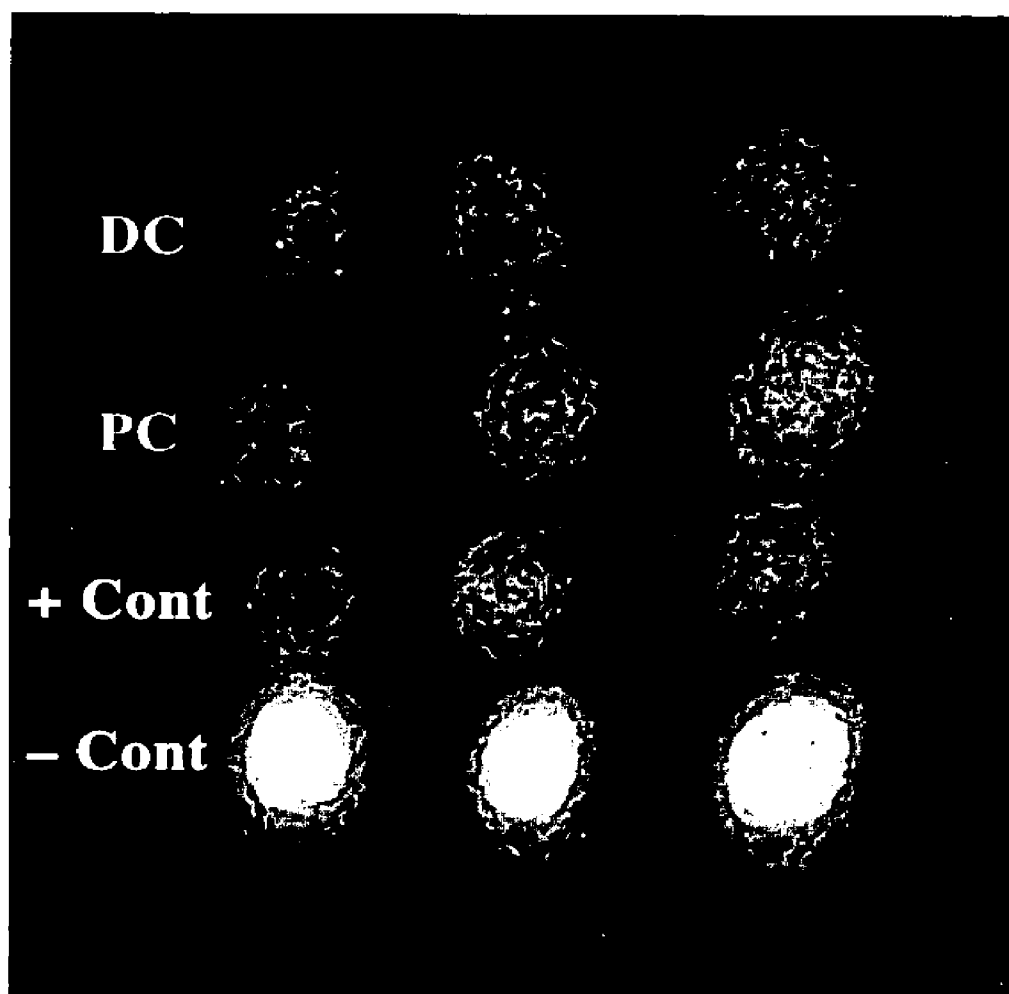
FIG. 2b



*FIG. 3a*

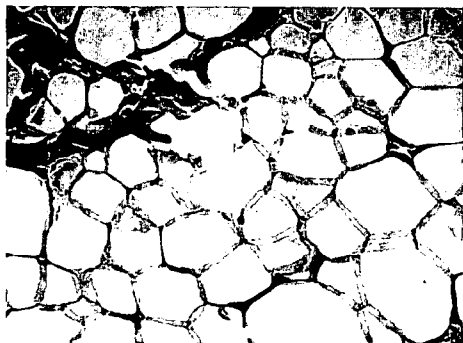


*FIG. 3b*

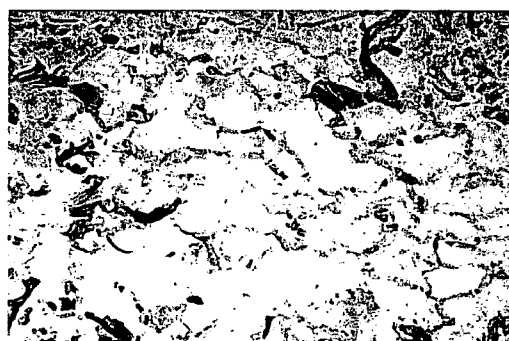


**FIG. 4**

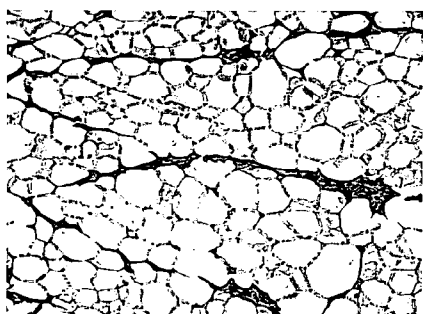
*FIG. 5a*



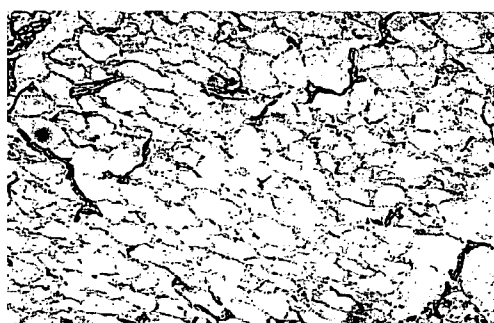
*FIG. 5b*



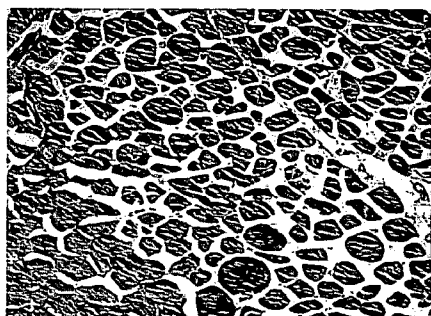
*FIG. 5c*



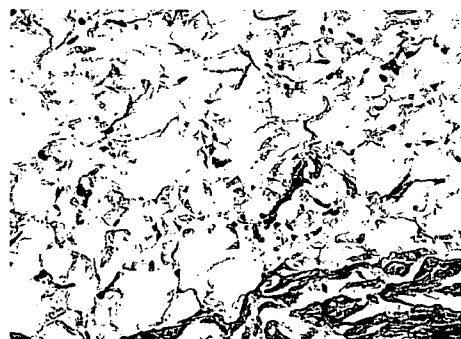
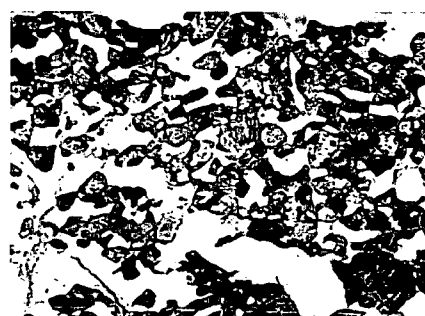
*FIG. 5d*



*FIG. 5e*



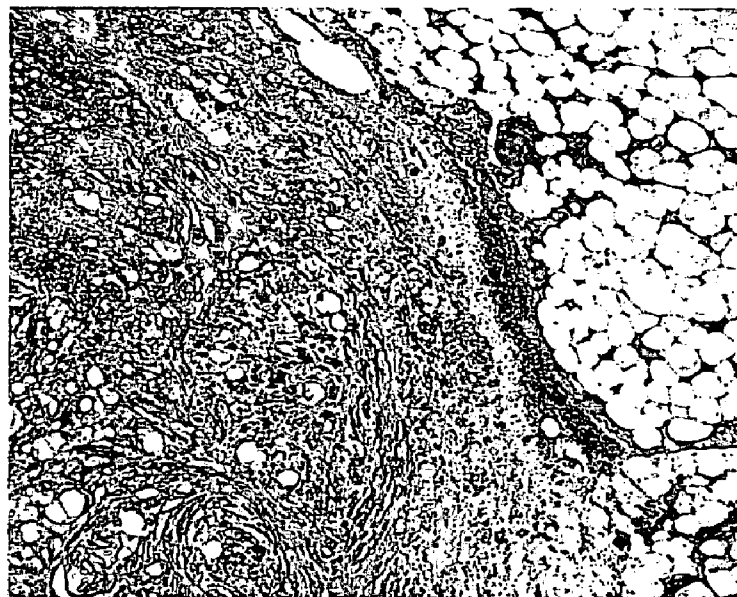
*FIG. 5f*



*FIG. 5g*

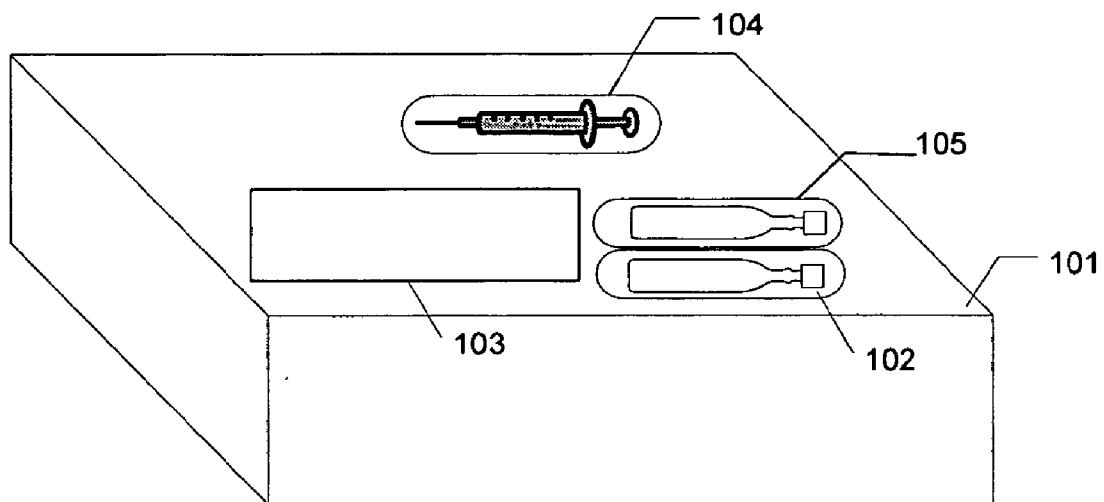


*FIG. 6a*



*FIG. 6b*

**FIG. 7**





## METHODS AND RELATED COMPOSITIONS FOR REDUCTION OF FAT

### CROSS-REFERENCE

**[0001]** The present application claims priority to U.S. Provisional Application Ser. No. 60/572,879 filed May 19, 2004, which is incorporated herein by reference in its entirety.

### FIELD OF THE INVENTION

**[0002]** The present invention is related to compositions and methods useful for the non-surgical removal of localized fat accumulation. Specifically, the present invention is related to pharmacologically active detergent compositions than are suitable for injection directly into a treatment site of a patient in need of fat removal without the need for surgical intervention.

### BACKGROUND OF THE INVENTION

**[0003]** Numbers appearing in parentheses at the end of a sentence refer to specific references cited at the conclusion of this specification immediately before the claims.

**[0004]** Formulations containing phosphatidylcholine and bile salts (phosphatidylcholine bile salt formulations, PBF) are increasingly being utilized to treat localized fat accumulation (1-8). Several open label clinical studies have reported promising results using injections of PBFs for the treatment of localized fat accumulation, including lower eyelid fat herniation and "buffalo hump" lipodystrophy (1-3).

**[0005]** Phosphatidylcholine is a natural phospholipid that is an essential component of cell membranes and is important for normal cellular membrane composition and repair. Phosphatidylcholine is also the major delivery form of the essential nutrient choline. Choline itself is a precursor in the synthesis of the neurotransmitter acetylcholine, the methyl donor betaine and sphingolipids, including phosphatidylcholine and sphingomyelin among others. Phosphatidylcholine is also involved in the hepatic export of very-low-density lipoproteins.

**[0006]** Bile salts have been used to improve the aqueous solubility of phosphatidylcholine and more recently, medications like amphotericin B, Taxol®, and diazepam (9-14). Highly purified phosphatidylcholine can be combined with the secondary bile salt sodium deoxycholate, an anti-microbial, benzyl alcohol, and water to form a stable, mixed micelle preparation that can be rapidly sterilized and used for intravenous administration (12). Pharmaceutical preparations of this mixture, known as Essentiale® and Lipostabil®, are marketed in other countries for treatment of liver disease and hyperlipidemia, respectively (12,15).

**[0007]** Rittes first reported that injections of a PBF into subcutaneous fat reduced infraorbital fat herniation (1). Since then, physicians have been using the pharmaceutical preparations or similar, compounded PBFs, to treat lower eyelid fat herniation, as well as fat deposits on the thighs, abdomen, upper back, chin, and arms (2,3,5). These PBFs often lack the dl-alpha-tocopherol (vitamin E), B-vitamins, and adenosine monophosphate variably found in Essentiale® and Lipostabil® (2,16).

**[0008]** Phosphatidylcholine formulations are associated with localized burning sensations, erythema, transient urticaria and variable degrees of pruritus all of which usually resolve within a few days. More serious sequelae of ulceration and pain have also been seen. An infectious granuloma-

tous reaction has been reported in the thigh of a patient at the site of multiple phosphatidylcholine injections (7). Increased dosages of injected phosphatidylcholine have paralleled side effects seen with large doses of oral and intravenous formulations of Lipostabil® and include nausea, diarrhea, abdominal pain and syncope.

**[0009]** The mechanism whereby phosphatidylcholine-containing formulation cause reduction of subcutaneous fat deposits is unknown but several mechanisms have been proposed (4). The first is that phosphatidylcholine could reduce the size of lipocytes by stimulating lipase activity. Alternatively, the PBFs have been postulated to function as a detergent that emulsifies lipocyte cell membranes. Detergents have been used in medicine for decades, specifically, as sclerosing agents commonly used in sclerotherapy (American College of Phlebology, 2003). Detergents possess unique polar and non-polar chemical properties which facilitates emulsification of insoluble substances by reducing surface tension at their interface (17). In fact, laboratory detergents like Triton® X-100 and Empigen® BB are commonly used to disrupt the lipid bilayer of cell membranes (10,18-21). Two major components of the PBFs, phosphatidylcholine and sodium deoxycholate, have these unique chemical properties and therefore have been used independently as detergents or emulsifying agents (9,18,20-25).

**[0010]** Surgical and non-surgical procedures for improving appearance have increased in prevalence as populations age and gain weight. Liposuction is one of the most popular cosmetic surgery procedures and involves the surgical removal of fat deposits using suction and optionally assisted by solutions to assist in fat removal. Liposuction, also known as lipoplasty or suction lipectomy, is a surgical procedure that removes fat through an incision in the skin through which a cannula is inserted. The cannula is connected to a suction source and the unwanted fat is aspirated through the cannula and discarded. Liposuction is performed under general or local anesthesia, depending on the amount and location of the fat to be removed.

**[0011]** The most commonly used forms of liposuction additionally use fluid injection methodologies wherein a medicated solution containing a mixture of salts, an anesthetic and a vasoconstrictor, is infused into the treatment site prior to aspiration of the fat tissue. The medicated solution helps the fat be removed more easily, reduces blood loss and provides anesthesia both during and after surgery.

**[0012]** In an example of adjuvant solutions for liposuction, a United States patent filed on Apr. 22, 1997 and issued as U.S. Pat. No. 5,891,083 on Apr. 6, 1999 by Capella and Capella teaches liposuction and a carrier solution containing a compound for an improved surgical procedure for removing subcutaneous fat. In one embodiment the Capella patent discloses the compound is an enzyme, particularly lipase or colipase. The enzyme is added to a carrier such as saline solution to provide a lipolysis solution. In another embodiment of the invention, Capella teaches emulsifying agents such as bile salts may also be beneficial in combination or as the primary active compound added to the solution. In every embodiment of the Capella invention, the lipolysis solution is administered for a period of time before liposuction to allow for the solution to infiltrate the fat tissue. Nowhere in Capella is the use of a lipolysis solution alone disclosed as a non-surgical means for removing fat from the body. In all examples and specific embodiments disclosed in Capella,

liposuction is used as a surgical procedure for fat removal and lipase and bile salts are provided as an adjuvant to liposuction.

**[0013]** However, liposuction and other surgical methods of fat removal are associated with significant adverse events including temporary bruising, swelling, numbness, soreness and burning sensation, risk of infection, pigmentation changes; the formation of fat clots or blood clots which can migrate to the lungs and cause death, excessive fluid loss, which can lead to shock or fluid accumulation that must be drained, friction burns or other damage to the skin or nerves or perforation injury to the vital organs. Additionally, liposuction requires a recovery time of one to two weeks wherein the patient cannot work or perform certain daily activities. Moreover, because surgical procedures such as liposuction require local and occasionally general anesthesia, significant anesthesia-related risks are associated with surgical fat removal.

**[0014]** Therefore it would be desirable to have a method of removing localized fat accumulations that does not require surgery or prolonged recovery time and has fewer adverse side effects than currently available methods.

#### SUMMARY OF THE INVENTION

**[0015]** The present invention provides methods and kits for reducing subcutaneous fat deposits. In one aspect, the invention contemplates kits having a first container comprising a pharmacologically active detergent and less than 5% w/v phosphatidylcholine, as well as written instructions for reducing subcutaneous fat deposits in a mammal without the use of surgery. Preferably, the kits herein may be used to reduce fat deposits in a variety of mammals such as, for example, a human, a horse, a dog, or a cat. In some embodiments the mammal is a human.

**[0016]** In some preferred embodiments, the first container has a total volume of less than 500 ml and/or is provided as an injectable formulation. In other preferred embodiments, the first container may contain a % w/v of detergent greater than the % w/v of phosphatidylcholine or may contain no phosphatidylcholine. In one preferred embodiment, the present invention provides the detergent at a concentration above its critical micellar concentration (CMC). The kits may comprise a variety of pharmacologically active detergents such as, for example, a lipophilic detergent, a hydrophilic detergent, an ionic detergent, a non-ionic detergent, a glyceride, a bile salt, and a zwitterionic detergent. In a more preferred embodiment, the active detergent is a bile salt, most preferably sodium deoxycholate. A first container in the kit herein may, in some embodiments include less than 3 g detergent. In other embodiments, a first container in the kit herein may include more than 0.0002 g detergent. In any of the embodiments herein the first container may further include a second detergent.

**[0017]** Preferably, the first container may further comprise a second therapeutic agent such as, for example, an anti-microbial agent, a vasoconstrictor, an anti-thrombotic agent, an anti-coagulation agent, a suds-depressant, an anti-inflammatory agent, an analgesic, a dispersion agent, an anti-dispersion agent, a penetration enhancer, a steroid, a tranquilizer, a muscle relaxant, and an anti-diarrhea agent. In some embodiments the second therapeutic agent is an analgesic, anti-microbial agent, or an anti-inflammatory agent. More preferably, the second therapeutic agent is an analgesic, or most preferably lidocain. In another embodiment, the kit provides a second container comprising the second therapeutic agent as described herein.

**[0018]** One embodiment of the present invention contemplates a kit herein for reducing fat deposits under the eye, chin, or arm, as well as the buttock, calf, back, thigh, ankle, or stomach of a mammal. In another embodiment, the kit may reduce specific types of fat deposits such as, for example, eyelid fat herniation, lipomas, lipodystrophy, buffalo hump lipodystrophy, or fat deposits associated with cellulite.

**[0019]** In a second aspect, the present invention provides methods for reducing subcutaneous fat deposits in a mammal without surgery by administering a unit dose comprising an effective amount of a pharmacologically active detergent and less than 5% w/v phosphatidylcholine. In one embodiment, the methods do not include the step of actively removing the detergent. The methods may be used to reduce fat deposits in a variety of mammals as described herein.

**[0020]** In another embodiment, the method includes the step of administering less than 500 ml of a solution comprising an effective amount of detergent and less than 5% w/v phosphatidylcholine. In some preferred embodiments, the unit dose is administered locally and/or is repeated at least twice. In other preferred embodiments, the unit dose has a greater % w/v of detergent than % w/v of phosphatidylcholine and/or has a concentration of detergent above its CMC. The methods may use a variety of pharmacologically active detergents as described herein. In a more preferred embodiment, the active detergent in the unit dose is a bile salt, most preferably sodium deoxycholate.

**[0021]** Preferably, the methods herein may further comprise the administration of a second detergent and/or a second therapeutic agent. The methods may include the administration of a variety of second therapeutic agents as described herein. More preferably, the second therapeutic agent is an analgesic, most preferably lidocain.

**[0022]** One other embodiment contemplates one or more methods described herein to reduce fat deposits under the eye, chin, or arm, as well as the buttock, calf, back, thigh, ankle, or stomach of a mammal. In another embodiment, the methods may reduce specific types of fat deposits such as, for example, eyelid fat herniation, lipomas, lipodystrophy, buffalo hump lipodystrophy, or fat deposits associated with cellulite.

#### BRIEF DESCRIPTION OF THE DRAWINGS

**[0023]** FIG. 1 depicts the molecular structure of (a) phosphatidylcholine (b) sodium deoxycholate and (c) benzyl alcohol.

**[0024]** FIG. 2 depicts the effects of phosphatidylcholine bile formulation (PC Formula, PBF) and sodium deoxycholate alone on cultured cell viability according to the teachings of the present invention: (a) MTS assay measuring viability of keratinocytes exposed to the PC Formula and sodium deoxycholate alone; (b) Lactate dehydrogenase (LDH) assay measuring LDH release by cells exposed to the PC Formula and sodium deoxycholate alone.

**[0025]** FIG. 3 depicts the effects of PBF and sodium deoxycholate alone on primary porcine fat tissue according to the teachings of the present invention: (a) MTS assay producing purple pigment, indicating living cells, in fat specimens treated with the PBS buffer as negative control (-Cont), sodium deoxycholate alone (DC), the PBF (PC), and Triton® detergent as positive control (+Cont); (b) A comparison of fat cell viability between the different treatments.

**[0026]** FIG. 4 depicts calcein fluorescence in fat specimens treated with sodium deoxycholate alone (DC), PBF (PC),

Triton® detergent as positive control (+Cont), and PBS buffer as negative control (-Cont) according to the teachings of the present invention.

**[0027]** FIG. 5 depicts light microscopy of porcine skin biopsies after treatment with compositions made according to the teachings of the present invention revealing (a) control lipocytes and (b) lipocytes after PBF injection (H&E, original magnification,  $\times 20$ ); (c) control lipocytes and (d) lipocytes after injection of sodium deoxycholate alone (H&E, original magnification,  $\times 10$ ); (e) control muscle and (f) muscle after injection of phosphatidylcholine alone (H&E, original magnification,  $\times 10$ ); (g) fat after injection with Empigen® detergent (H&E, original magnification,  $\times 20$ ).

**[0028]** FIG. 6 depicts a lipoma removed from a patient two days after injection with deoxycholate according to the teachings of the present invention: (a) gross pathology and (b) histology (H&E, original magnification,  $\times 20$ ).

**[0029]** FIG. 7 depicts a kit for reducing a subcutaneous fat accumulation.

#### DETAILED DESCRIPTION OF THE INVENTION

**[0030]** The present invention addresses the problem of localized fat accumulation in mammals by providing a non-surgical method for reducing fat deposits by administration of fat-solubilizing concentrations of one or more detergents in pharmaceutically acceptable formulations.

**[0031]** Based on phosphatidylcholine's role as an emulsifier in bile and its use in the treatment of hyperlipidemia, phosphatidylcholine has been postulated as the active ingredient in PBFs (1, 2, 21, 25, 27). The detergents such as bile salts in these prior art compositions were added merely to disperse or solubilize the presumed active ingredient, PC. However, to date, there are no published reports supporting this theory. The present inventors have unexpectedly demonstrated that the bile salt was actually the active agent for localized fat emulsification.

**[0032]** Numbers appearing in parentheses at the end of a sentence refer to specific references cited at the conclusion of this specification immediately before the claims. All of the references cited herein are hereby incorporated by reference in their entirety for all purposes.

**[0033]** Phosphatidylcholine is a natural phospholipid that is an essential component of cell membranes and is important for normal cellular membrane composition and repair. Phosphatidylcholine is also the major delivery form of the essential nutrient choline. Choline itself is a precursor in the synthesis of the neurotransmitter acetylcholine, the methyl donor betaine and phospholipids, including phosphatidylcholine and sphingomyelin among others. Phosphatidylcholine is also involved in the hepatic export of very-low-density lipoproteins.

**[0034]** Bile salts have been used to improve the aqueous solubility of phosphatidylcholine and more recently, medications like amphotericin B, Taxol™, and diazepam (9-14). Highly purified phosphatidylcholine can be combined with the secondary bile salt sodium deoxycholate, an anti-microbial, benzyl alcohol, and water to form a stable, mixed micelle preparation that can be rapidly sterilized and used for intravenous administration (12). Pharmaceutical preparations of this mixture, known as Essentiale® and Lipostabil®, are marketed in other countries for treatment of liver disease and hyperlipidemia, respectively (12, 15).

**[0035]** Physicians have been using pharmaceutical preparations or compounded PBFs to treat lower eyelid fat hernia-

tion, as well as fat deposits on the thighs, abdomen, upper back, chin, and arms (2, 3, 5). These PBFs often lack the dl-alpha-tocopherol (vitamin E), B-vitamins, and adenosine monophosphate variably found in Essentiale® and Lipostabil® (2, 16).

**[0036]** Liposuction is one of the most popular cosmetic surgery procedures and involves the surgical removal of fat deposits using suction and optionally assisted by solutions to assist in fat removal. Liposuction, also known as lipoplasty or suction lipectomy, is a surgical procedure that reduces fat through an incision in the skin through which a cannula is inserted. The cannula is connected to a suction source and the unwanted fat is aspirated through the cannula and discarded. Liposuction is performed under general or local anesthesia, depending on the amount and location of the fat to be reduced. Such infusions consisted of large volumes of solution and are often forced out of the patient prior to or during a liposuction procedure. See U.S. Pat. No. 5,891,083.

**[0037]** The use of liposuction and/or other surgical methods of fat removal are associated with significant adverse events including temporary bruising, swelling, numbness, soreness and burning sensation, risk of infection, pigmentation changes; the formation of fat clots or blood clots which can migrate to the lungs and cause death, excessive fluid loss, which can lead to shock or fluid accumulation that must be drained, friction burns or other damage to the skin or nerves or perforation injury to the vital organs. Additionally, liposuction requires a recovery time of one to two weeks wherein the patient cannot work or perform certain daily activities. Moreover, because surgical procedures such as liposuction require local and occasionally general anesthesia, significant anesthesia-related risks are associated with surgical fat removal.

**[0038]** While meeting with some success, prior techniques and compositions have met with certain limitations. Therefore it would be desirable to have a method of reducing localized fat accumulations that does not require surgery or prolonged recovery time and has fewer adverse side effects than currently available methods.

**[0039]** The present invention relates to the use of one or more pharmacologically active detergents (e.g., bile salts) to reduce subcutaneous fat accumulations in a mammal by administering such formulation locally to a target site.

**[0040]** Among detergents, bile salts are particularly potent solubilizers of lipid bilayer membranes (9, 20, 21, 23, 28). All biologic cell membranes are composed of the same bilipid structure, and are therefore subject to solubilization by detergents (10, 19, 34). Solubilization of cell membranes by a detergent involves distribution of the detergent between lipid bilayers, destabilization of the bilayer, disintegration, and subsequent formation of mixed micelles (composed of detergent and cell membrane lipid) (10, 19, 21). Bile salts, and other detergents, decrease surface tension at the border of immiscible materials and allows the breakdown of large aggregates into smaller and smaller particles. In tissue, these agents dissolve cell membranes and cause cell lysis. An inflammatory response is generated, causing the body to remove the detergent solubilized material.

**[0041]** For this reason, the present inventors compared sodium deoxycholate with the complete PBF using a simple, quantitative assay measuring cell viability (FIG. 2a). It is not possible to isolate and test pure phosphatidylcholine because it is insoluble in aqueous solutions unless it is combined with substances like bile salts (12). Phosphatidylcholine is highly soluble in ethanol, methanol, chloroform, and other organic

solvents, yet these agents can damage lipid bilayers (29-31). In preliminary experiments, there was no difference in cell lysis and histology between pure, isolated PC and the ethanol used to dissolve it. Although benzyl alcohol, one of the components of the PC formula, has been shown to affect the fluidity of cell membranes, it is not a detergent, and therefore, its limited quantity in the formula has negligible lytic effects on cell membranes (32, 33).

**[0042]** Because penetration into intact tissues may be likely a limiting factor, cell cultures were used to determine the dilutions of the reagents (PBF and deoxycholate) necessary to affect cells. Deoxycholate profoundly decreased the viability of cultured cells approximately equal to the complete PBF (FIG. 2a). This finding was reproduced in tissue by exposing porcine fat to PBF and deoxycholate (FIG. 3). These results support the unexpected observation that sodium deoxycholate plays a major, active role in the PBF.

**[0043]** The present invention is based on the use of detergent action of disrupting cell membrane to reduce subcutaneous fat deposits. Membrane lysis in cultured cells was measured using a lactate dehydrogenase (LDH) assay and within tissue using calcein, a fluorescent marker retained in cells with intact cell membranes. The LDH assay measures the activity of LDH, which is a cytosolic enzyme released when cells are lysed. Both the PBF- and deoxycholate-treated cell cultures demonstrated a concentration-dependent increase in cell lysis (FIG. 2b). Moreover, the direct lytic effects observed in cultured cells treated with these agents suggest activity independent of endogenous lipase. Calcein was lost in the fat specimens exposed to the PBF, deoxycholate, and Triton® X-100, a known laboratory detergent (FIG. 4). This finding confirmed that disruption of cell membranes occurs in fresh tissue exposed to both the PBF and deoxycholate.

**[0044]** Comparing the effects of the PBF to deoxycholate in cell culture led to the surprising result that deoxycholate caused similar loss of cell viability, but less cell lysis. These differences may be concentration dependent or there may be synergistic effects between phosphatidylcholine and deoxycholate within the formula. Nonetheless, the data demonstrate that, at concentrations similar to those used clinically, deoxycholate and the PBF had similar effects on tissue histology and cell viability. Taken together, these data unexpectedly demonstrate that deoxycholate acts as the active component in the prior art PBF.

**[0045]** In order to illustrate the effect of detergents on tissue histology, fresh porcine skin was injected with PBF, deoxycholate, and well-characterized laboratory detergents (FIG. 5). All reagents caused significant disruption of lipocyte organization compared to PBS injection (control). These results were similarly observed within muscle and connective tissue. Rapid dissolution of cell borders by the test substances and the similarity of their effects to well characterized detergents substantiate that the PBF and deoxycholate function as detergents. The limitation with this experimental model is that it does not reveal the true sequelae that occur after injection into living tissue. It is apparent from clinical reports that a brisk inflammatory response, evident as erythema and edema, occurs after injection (1-3). Repeated inflammation can potentially lead to fibrosis, especially after multiple injections. Fibrosis has been reported in several patients who developed firm nodules at injection sites after PBF administration that eventually resolve over several months (35).

**[0046]** Histologic findings reveal that the injectable PBF and deoxycholate alone cause architectural disruption in fat and muscle, but had no apparent effect on the epidermis, dermis, or adnexae (FIG. 5). However, Empigen® BB, a potent laboratory detergent, had profound histologic effects on dermal collagen (connective tissue). Alternatively, fat and muscle can be more sensitive to detergent treatment than these other structures at the tested concentrations (similar to those used in clinical practice).

**[0047]** Through a series of laboratory experiments utilizing fresh tissue specimens and cell cultures, the present inventors have demonstrated that the prior art PBF popularly used in subcutaneous injections for fat dissolution works primarily by causing non-specific lysis of cell membranes. Cell membranes are constituents of all tissue types; specifically, the present inventor demonstrated that these detergents cause solubilization of fat, muscle and connective tissue. Therefore the present inventors concluded that sodium deoxycholate, the bile salt component of the formula used to dissolve the phosphatidylcholine, was the major active ingredient of these prior art formulations. This conclusion is supported by the fact that pharmacologically active detergents, such as bile salts are potent solubilizers of cell membranes. Moreover, the mechanism of the PBF and sodium deoxycholate in fat dissolution is likely detergent action.

**[0048]** Compositions

**[0049]** In an embodiment of the present invention, a medical composition of biologically compatible detergents includes one or more pharmacologically active detergents and pharmaceutically acceptable excipients in an aqueous vehicle. In particular, it is within the scope of the present invention that pharmacologically active detergents including bile salts are used to dissolve fat.

**[0050]** In one embodiment, the present invention relates compositions comprise, consist essentially of, or consist of one or more pharmacologically active detergents in an effective amount to reduce subcutaneous fat.

**[0051]** Pharmacologically active detergents that can be used in embodiments of the present invention include, but are not limited to, lipophilic detergents (whether ionic or non-ionic), hydrophilic detergents (whether ionic or non-ionic), ionic detergents, non-ionic detergents, zwitterionic detergents, glycerides, and bile salts.

**[0052]** Non-limiting examples of lipophilic detergents include, inter alia, alcohols; polyoxyethylene alkylethers; fatty acids, bile acids; glycerol fatty acid esters; acetylated glycerol fatty acid esters; lower alcohol fatty acids esters; polyethylene glycol fatty acid esters; polyethylene glycol glycerol fatty acid esters; polypropylene glycol fatty acid esters; polyoxyethylene glycerides; lactic acid derivatives of mono/diglycerides; propylene glycol diglycerides; sorbitan fatty acid esters; polyoxyethylene sorbitan fatty acid esters; polyoxyethylene-polyoxypropylene block copolymers; transesterified vegetable oils; sterols; sterol derivatives; sugar esters; sugar ethers; sucroglycerides; polyoxyethylene vegetable oils; polyoxyethylene hydrogenated vegetable oils; reaction mixtures of polyols and at least one member of the group consisting of fatty acids, glycerides, vegetable oils, hydrogenated vegetable oils, and sterols; and mixtures thereof.

**[0053]** Non-limiting examples of non-ionic lipophilic detergents include, inter alia, alkylglucosides; alkylmalto-sides; alkylthiogluco-sides; lauryl macrogolglycerides; polyoxyethylene alkyl ethers; polyoxyethylene alkylphenols;

polyethylene glycol fatty acids esters, polyethylene glycol glycerol fatty acid esters; polyoxyethylene sorbitan fatty acid esters; polyoxyethylene-polyoxypropylene block copolymers; polyglycerol fatty acid esters; polyoxyethylene glycerides; polyoxyethylene sterols, derivatives, and analogues thereof; polyoxyethylene vegetable oils; polyoxyethylene hydrogenated vegetable oils; reaction mixtures of polyols and at least one member of the group consisting of fatty acids, glycerides, vegetable oils, hydrogenated vegetable oils, and sterols; tocopherol polyethylene glycol succinates; sugar esters; sugar ethers; sucroglycerides; and mixtures thereof.

**[0054]** Non-limiting examples of ionic hydrophilic detergents include, inter alia, alkyl ammonium salts, bile acids and salts, analogues, and derivatives thereof; fatty acid derivatives of amino acids, carnitines, oligopeptides, and polypeptides; glyceride derivatives of amino acids, oligopeptides, and polypeptides; acyl lactylates; mono-, diacetylated tartaric acid esters of mono-, diglycerides; succinoylated monoglycerides; citric acid esters of mono-, diglycerides; alginate salts; propylene glycol alginate; lecithins and hydrogenated lecithins; lysolecithin and hydrogenated lysolecithins; lysophospholipids and derivatives thereof, phospholipids and derivatives thereof; salts of alkylsulphates; salts of fatty acids; sodium docusate; and mixtures thereof.

**[0055]** Non-limiting examples of ionic detergents include, but not limited to, cholate, sodium deoxycholate, sodium dodecylsulfate and C-16 TAB. In preferred embodiment, a non-limiting example of an ionic detergent useful in an embodiment of the present invention is sodium deoxycholate.

**[0056]** Non-limiting examples of non-ionic detergents include, but not limited to, Brij 35, n-alkyl PEO monoether such as, polyoxyethylen(20)cetyl ether, Lubrol PX, Lubrol WX, nonidet P-40, n-alkyl phenyl PEO such as, octylphenolpoly(ethyleneglycolether)n10, and octylphenolpoly(ethyleneglycolether)n7, tetramethylbutylphenyl PEO, n-octylglucoside, octyl-thioglucoopyranoside, tween-80 and tween-20, and alkylaryl polyether alcohol (Triton® X-100).

**[0057]** Non-limiting examples of zwitterionic detergents include, but not limited to, 3-[(3-cholamidopropyl)dimethylammonio]propane-sulfonate (CHAPS), N-tetradecyl-N,N-dimethyl-3-ammoniu-1-propanesulfonate, cholic acid sulfobetaine, lauryldimethylbetaine (Empigen® BB) and zwittergent 3-14.

**[0058]** Non-limiting examples of glycerides include, inter alia, mono-, di- or tri-glycerides. Such triglycerides include, inter alia, vegetable oils, fish oils, animal fats, hydrogenated vegetable oils, partially hydrogenated vegetable oils, synthetic triglycerides, modified triglycerides, fractionated triglycerides, and mixtures thereof.

**[0059]** Non-limiting examples of bile salts include steroids having 1-3 hydroxyl groups and a five carbon atom side chain terminating in a carboxyl group, which can be conjugated to glycine or taurine.

**[0060]** Additional examples of bile salts include salts of cholate, deoxycholic, cholic, chenodeoxycholic, 7-alpha-dehydroxylate, chenodeoxycholic, lithocholic, ursodeoxycholic, dihydroxy- and trihydroxy- and taurine or glycine conjugates of any of the above. Preferably a bile salt of the invention is sodium deoxycholate.

**[0061]** Table 1 below illustrates several detergents contemplated by the present invention, their monomeric molecular weight of these detergents as monomers, and their critical

micellar concentration (CMCs), which is the minimum concentration at which the detergent is predominantly in the form of micelles.

TABLE 1

Detergent Name	Molecular Weight (AMU)	Micellar Molecular Weight (AMU)	CMC in H <sub>2</sub> O (M)
<b>Anionic</b>			
Cholate	430	4300	1.4 × 10 <sup>-2</sup>
Deoxycholate	415-432	4200	5 × 10 <sup>-3</sup>
Sodium dodecyl sulfate	288	18000	8.3 × 10 <sup>-3</sup>
<b>cationic</b>			
C16-TAB	365	62000	1 × 10 <sup>-3</sup>
<b>Amphoteric (Zwitterionic)</b>			
Cholic acid-sulfobetaine	615	6150	4 × 10 <sup>-3</sup>
Cholic acid-sulfobetaine	631	6940	8 × 10 <sup>-3</sup>
Lysophosphatidylcholine	495	92000	7 × 10 <sup>-6</sup>
Zwittergent 3-14	364	30000	3 × 10 <sup>-4</sup>
<b>Non-Ionic</b>			
Brij 35	1225	49000	9 × 10 <sup>-5</sup>
polyoxyethylen(20)cetyl ether	1120	82000	7.7 × 10 <sup>-5</sup>
Lubrol PX	582	64000	1 × 10 <sup>-4</sup>
Nonidet P-40	603	90000	3 × 10 <sup>-4</sup>
Octylphenolpoly (ethyleneglycolether)n10	647	90000	0.2 × 10 <sup>-3</sup>
Octylphenolpoly (ethyleneglycolether)n7	515		0.2 × 10 <sup>-3</sup>
n-Octylglucoside	292	8000	14.5 × 10 <sup>-3</sup>
Octyl-thioglucoopyranoside	308		9 × 10 <sup>-3</sup>
Tween-80	1310	76000	1.2 × 10 <sup>-5</sup>
Tween-20	1228		6.0 × 10 <sup>-5</sup>

**[0062]** Preferably, the concentration of the one or more pharmacologically active detergents in a composition herein is such that it is at approximately the CMC concentration (i.e. +/-5 mM), or at a concentration that is above the CMC level, such as more than 1%, 5%, 10%, 15%, 20%, 25%, 30%, 35%, 40%, 50%, 55%, 60%, 65%, 70%, 75%, 80%, 85%, 90%, 99%, 150%, 200%, 400%, 800%, 1600%, 3200%, 6800%, 13,600%, 27,200%, or 54,400%, above the CMC concentration level.

**[0063]** In some embodiments, a concentration of the one or more of the pharmacologically active detergents in a composition is less than 20%, 19%, 18%, 17%, 16%, 15%, 14%, 13%, 12%, 11%, 10%, 9%, 8%, 7%, 6%, 5%, 4%, 3%, 2%, 1%, 0.5%, 0.4%, 0.3%, 0.2%, 0.1%, 0.09%, 0.08%, 0.07%, 0.06%, 0.05%, 0.04%, 0.03%, 0.02%, 0.01%, 0.009%, 0.008%, 0.007%, 0.006%, 0.005%, 0.004%, 0.003%, 0.002%, 0.001%, 0.0009%, 0.0008%, 0.0007%, 0.0006%, 0.0005%, 0.0004%, 0.0003%, 0.0002%, or 0.0001% w/w, w/v or v/v.

**[0064]** In some embodiments, a concentration of the one or more of the pharmacologically active detergents in a composition is greater than 20%, 19.75%, 19.50%, 19.25% 19%, 18.75%, 18.50%, 18.25% 18%, 17.75%, 17.50%, 17.25% 17%, 16.75%, 16.50%, 16.25% 16%, 15.75%, 15.50%, 15.25% 15%, 14.75%, 14.50%, 14.25% 14%, 13.75%, 13.50%, 13.25% 13%, 12.75%, 12.50%, 12.25% 12%, 11.75%, 11.50%, 11.25% 11%, 10.75%, 10.50%, 10.25% 10%, 9.75%, 9.50%, 9.25% 9%, 8.75%, 8.50%, 8.25% 8%, 7.75%, 7.50%, 7.25% 7%, 6.75%, 6.50%, 6.25% 6%, 5.75%, 5.50%, 5.25% 5%, 4.75%, 4.50%, 4.25%, 4%, 3.75%, 3.50%, 3.25%, 3%, 2.75%, 2.50%, 2.25%, 2%, 1.75%, 1.50%, 1.25% , 1%, 0.5%, 0.4%, 0.3%, 0.2%, 0.1%, 0.09%, 0.08%, 0.07%,

0.06%, 0.05%, 0.04%, 0.03%, 0.02%, 0.01%, 0.009%, 0.008%, 0.007%, 0.006%, 0.005%, 0.004%, 0.003%, 0.002%, 0.001%, 0.0009%, 0.0008%, 0.0007%, 0.0006%, 0.0005%, 0.0004%, 0.0003%, 0.0002%, or 0.0001% w/w, w/v, or v/v.

**[0065]** In some embodiments, a concentration of the one or more of the pharmacologically active detergents in a composition is in the range from approximately 0.001% to approximately 50%, approximately 0.001% to approximately 40%, approximately 0.01% to approximately 30%, approximately 0.02% to approximately 29%, approximately 0.03% to approximately 28%, approximately 0.04% to approximately 27%, approximately 0.05% to approximately 26%, approximately 0.06% to approximately 25%, approximately 0.07% to approximately 24%, approximately 0.08% to approximately 23%, approximately 0.09% to approximately 22%, approximately 0.1% to approximately 21%, approximately 0.2% to approximately 20%, approximately 0.3% to approximately 19%, approximately 0.4% to approximately 18%, approximately 0.5% to approximately 17%, approximately 0.6% to approximately 16%, approximately 0.7% to approximately 15%, approximately 0.8% to approximately 14%, approximately 0.9% to approximately 12%, approximately 1% to approximately 10% w/w, w/v or v/v. It is understood that the final concentration is dependent on many factors known to persons skilled in the art including, but not limited to, location and size of the target site.

**[0066]** In some embodiments, a composition herein comprises, consists essentially of, or consists of less than 10 g, 9.5 g, 9.0 g, 8.5 g, 8.0 g, 7.5 g, 7.0 g, 6.5 g, 6.0 g, 5.5 g, 5.0 g, 4.5 g, 4.0 g, 3.5 g, 3.0 g, 2.5 g, 2.0 g, 1.5 g, 1.0 g, 0.95 g, 0.9 g, 0.85 g, 0.8 g, 0.75 g, 0.7 g, 0.65 g, 0.6 g, 0.55 g, 0.5 g, 0.45 g, 0.4 g, 0.35 g, 0.3 g, 0.25 g, 0.2 g, 0.15 g, 0.1 g, 0.09 g, 0.08 g, 0.07 g, 0.06 g, 0.05 g, 0.04 g, 0.03 g, 0.02 g, 0.01 g, 0.009 g, 0.008 g, 0.007 g, 0.006 g, 0.005 g, 0.004 g, 0.003 g, 0.002 g, 0.001 g, 0.0009 g, 0.0008 g, 0.0007 g, 0.0006 g, 0.0005 g, 0.0004 g, 0.0003 g, 0.0002 g, or 0.0001 g of the one or more pharmacologically active detergents herein.

**[0067]** In some embodiments, a composition herein comprises, consists essentially of, or consists of more than 0.0001 g, 0.0002 g, 0.0003 g, 0.0004 g, 0.0005 g, 0.0006 g, 0.0007 g, 0.0008 g, 0.0009 g, 0.001 g, 0.0015 g, 0.002 g, 0.0025 g, 0.003 g, 0.0035 g, 0.004 g, 0.0045 g, 0.005 g, 0.0055 g, 0.006 g, 0.0065 g, 0.007 g, 0.0075 g, 0.008 g, 0.0085 g, 0.009 g, 0.0095 g, 0.01 g, 0.015 g, 0.02 g, 0.025 g, 0.03 g, 0.035 g, 0.04 g, 0.045 g, 0.05 g, 0.055 g, 0.06 g, 0.065 g, 0.07 g, 0.075 g, 0.08 g, 0.085 g, 0.09 g, 0.095 g, 0.1 g, 0.15 g, 0.2 g, 0.25 g, 0.3 g, 0.35 g, 0.4 g, 0.45 g, 0.5 g, 0.55 g, 0.6 g, 0.65 g, 0.7 g, 0.75 g, 0.8 g, 0.85 g, 0.9 g, 0.95 g, 1 g, 1.5 g, 2 g, 2.5 g, 3 g, 3.5 g, 4 g, 4.5 g, 5 g, 5.5 g, 6 g, 6.5 g, 7 g, 7.5 g, 8 g, 8.5 g, 9 g, 9.5 g, or 10 g of the one or more pharmacologically active detergents herein.

**[0068]** In some embodiments, a composition herein comprises, consists essentially of, or consists of 0.0001-10 g, 0.0005-9 g, 0.001-8 g, 0.005-7 g, 0.01-6 g, 0.05-5 g, 0.1-4 g, 0.5-4 g, or 1-3 g of the one or more pharmacologically active detergents herein.

**[0069]** In any of the embodiment herein, a composition can comprise, consist essentially of, or consist of at least 2, 3, 4, 5, 6, 7, 8, 9, or 10 detergents.

**[0070]** In any of the embodiments herein, a composition can include one or more phospholipids (e.g., phosphatidylcholine). Preferably, the amount of phospholipids in a composition/unit dose herein is at a concentration less than 50%,

40%, 30%, 20%, 15%, 10%, 9%, 8%, 7%, 6%, 5%, 4%, 3%, 2%, 1%, 0.95%, 0.9%, 0.85%, 0.8%, 0.75%, 0.7%, 0.65%, 0.6%, 0.55%, 0.5%, 0.45%, 0.4%, 0.35%, 0.3%, 0.25%, 0.2%, 0.15%, 0.1%, 0.09%, 0.08%, 0.07%, 0.06%, 0.05%, 0.04%, 0.03%, 0.02%, 0.01%, 0.009%, 0.008%, 0.007%, 0.006%, 0.005%, 0.004%, 0.003%, 0.002%, 0.001%, 0.0009%, 0.0008%, 0.0007%, 0.0006%, 0.0005%, 0.0004%, 0.0003%, 0.0002%, or 0.0001% w/w, w/v, or v/v of the composition or unit dose. In preferred embodiments, the amount of phospholipids in a composition is at a concentration less than 5% w/w, w/v, or v/v.

**[0071]** In one embodiment of the present invention, a medical composition for the non-surgical reduction of localized fat deposits in a patient is provided which comprises at least one pharmacologically active detergent, optionally at least one pharmaceutically acceptable excipient and optionally at least one additional active ingredient wherein the medical composition and contains less than 20%, 19%, 18%, 17%, 16%, 15%, 14%, 13%, 12%, 11%, 10%, 9%, 8%, 7%, 6%, 5%, 4%, 3%, 2%, 1%, 0.5%, 0.4%, 0.3%, 0.2%, 0.1%, 0.09%, 0.08%, 0.07%, 0.06%, 0.05%, 0.04%, 0.03%, 0.02%, 0.01%, 0.009%, 0.008%, 0.007%, 0.006%, 0.005%, 0.004%, 0.003%, 0.002%, 0.001%, 0.0009%, 0.0008%, 0.0007%, 0.0006%, 0.0005%, 0.0004%, 0.0003%, 0.0002%, or 0.0001% w/w, w/v, or v/v of phospholipids (such as phosphatidylcholine), or more preferably does not contain any phospholipids, such as phosphatidylcholine. The term "less than" as used herein when refers generally to a composition containing some phosphatidylcholine, but in some embodiments refers to 0% phosphatidylcholine.

**[0072]** In an embodiment of the present invention, the pharmacologically active detergent composition contains at least one pharmacologically active detergent, optionally at least one pharmaceutically acceptable excipient and optionally at least one additional active ingredient, and wherein the pharmacologically active detergent composition contains less than 20%, 19%, 18%, 17%, 16%, 15%, 14%, 13%, 12%, 11%, 10%, 9%, 8%, 7%, 6%, 5%, 4%, 3%, 2%, 1%, 0.5%, 0.4%, 0.3%, 0.2%, 0.1%, 0.09%, 0.08%, 0.07%, 0.06%, 0.05%, 0.04%, 0.03%, 0.02%, 0.01%, 0.009%, 0.008%, 0.007%, 0.006%, 0.005%, 0.004%, 0.003%, 0.002%, 0.001%, 0.0009%, 0.0008%, 0.0007%, 0.0006%, 0.0005%, 0.0004%, 0.0003%, 0.0002%, or 0.0001% w/w, w/v, or v/v of phospholipids (such as phosphatidylcholine), or more preferably does not contain any phospholipids, such as phosphatidylcholine.

**[0073]** In embodiments of the present invention, the pharmacologically active detergent composition is administered by subcutaneous injection directly into fat tissue.

**[0074]** In an embodiment of the present invention, the localized fat accumulation is lower eyelid fat herniation, lipomas, lipodystrophy, buffalo hump lipodystrophy or fat deposits associated with cellulite. Localized fat accumulations can be present in, for example, under eye, under chin, under arm, buttock, calf, ankle, back, thigh, or stomach. Thus, the present invention contemplates treatment of adipose tissue disorders such as lipomas, Dercum's disease, Madelung's neck, lipedema, piezogenic nodules, xanthelasma, lipodystrophy, and cellulite.

**[0075]** In another embodiment of the present invention, a medical composition is provided for reducing localized accumulation of fat in a patient with lower eyelid fat herniation comprising a fat solubilizing amount of deoxycholic acid, and the medical composition contains less than 20%, 19%, 18%, 17%, 16%, 15%, 14%, 13%, 12%, 11%, 10%, 9%, 8%, 7%,

6%, 5%, 4%, 3%, 2%, 1%, 0.5%, 0.4%, 0.3%, 0.2%, 0.1%, 0.09%, 0.08%, 0.07%, 0.06%, 0.05%, 0.04%, 0.03%, 0.02%, 0.01%, 0.009%, 0.008%, 0.007%, 0.006%, 0.005%, 0.004%, 0.003%, 0.002%, 0.001%, 0.0009%, 0.0008%, 0.0007%, 0.0006%, 0.0005%, 0.0004%, 0.0003%, 0.0002%, or 0.0001% w/w, w/v, or v/v phospholipids (such as phosphatidylcholine), or more preferably does not contain any phospholipids, such as phosphatidylcholine.

**[0076]** In an embodiment of the present invention a non-liposuction method for the non-surgical reduction of localized fat deposits in a patient is provided comprising the non-surgical administration of a pharmacologically active detergent composition consisting essentially of at least one pharmacologically active detergent, optionally at least one pharmaceutically acceptable excipient and optionally at least one additional active ingredient, and the medical composition and preferably contains less than 20%, 19%, 18%, 17%, 16%, 15%, 14%, 13%, 12%, 11%, 10%, 9%, 8%, 7%, 6%, 5%, 4%, 3%, 2%, 1%, 0.5%, 0.4%, 0.3%, 0.2%, 0.1%, 0.09%, 0.08%, 0.07%, 0.06%, 0.05%, 0.04%, 0.03%, 0.02%, 0.01%, 0.009%, 0.008%, 0.007%, 0.006%, 0.005%, 0.004%, 0.003%, 0.002%, 0.001%, 0.0009%, 0.0008%, 0.0007%, 0.0006%, 0.0005%, 0.0004%, 0.0003%, 0.0002%, or 0.0001% w/w, w/v, or v/v phospholipids (such as phosphatidylcholine), or more preferably does not contain any phospholipids, such as phosphatidylcholine.

**[0077]** In any of the compositions herein the ratio between the detergent(s) and phospholipids is such there is more detergents by mass than phospholipids. For example, the mass ratio of detergent(s) and phospholipids may be 1:0.5, 1:0.05, 1:0.005, etc. In some embodiments, the concentration of the phospholipids (e.g., phosphatidylcholine) in %w/v is less than the concentration of % w/v of the detergent(s). For example, a composition may have 5% w/v sodium deoxycholate and 4% w/v phosphatidylcholine.

**[0078]** Unit Dose

**[0079]** The present invention also contemplates a unit dose of the compositions herein. Such unit dose can have, for example, a total volume of less than 500 mL, 400 mL, 300 mL, 200 mL, 100 mL, 90 mL, 80 mL, 70 mL, 60 mL, 50 mL, 40 mL, 30 mL, 20 mL, 10 mL, 9 mL, 8 mL, 7 mL, 6 mL, 5 mL, 4 mL, 3 mL, 2 mL, 1 mL, 0.9 mL, 0.8 mL, 0.7 mL, 0.6 mL, 0.5 mL, 0.4 mL, 0.3 mL, 0.2 mL, 0.1 mL, 0.09 mL, 0.08 mL, 0.07 mL, 0.06 mL, 0.05 mL, 0.04 mL, 0.03 mL, 0.02 mL, 0.01 mL, 0.009 mL, 0.008 mL, 0.007 mL, 0.006 mL, 0.005 mL, 0.004 mL, 0.003 mL, 0.002 mL, 0.001 mL, 0.0009 mL, 0.0008 mL, 0.0007 mL, 0.0006 mL, 0.0005 mL, 0.0004 mL, 0.0003 mL, 0.0002 mL, or 0.0001 mL. In some embodiments, such unit dose has a total volume of more than 0.2 mL and less than 500 mL. In some embodiments, such unit dose has a total volume of less than 0.1 mL. In some embodiments, such unit dose has a total volume of less than 0.1 mL. In some embodiments, such unit dose has total volume of 0.1-0.2 mL (inclusive of 0.1 mL and 0.2 mL). In some embodiments, such unit dose has total volume of less than 0.1 and greater than 0.2.

**[0080]** In some embodiments, the present invention contemplates administration a composition or unit dose that is greater 0.0001 mL, 0.0005 mL, 0.001 mL, 0.005 mL, 0.01 mL, 0.05 mL, 0.1 mL, 0.5 mL, 1 mL, 5 mL, 10 mL, 50 mL, 100 mL of total volume to target site.

**[0081]** In some embodiments, the present invention contemplates administration of a unit dose having a total volume in the range of 0.0001-500 mL, 0.0005-400 mL, 0.001-300 mL, 0.005-200 mL, 0.01-100 mL, 0.05-90 mL, 0.06-80 mL,

0.07-70 mL, 0.08-60 mL, 0.09-50 mL, 0.1-40 mL, 0.2-30 mL, 0.3-29 mL, 0.4-28 mL, 0.5-27 mL, 0.6-26 mL, 0.7-25 mL, 0.8-24 mL, 0.9-23 mL, 10-22 mL, 11-21 mL, 12-20 mL, 13-19 mL, 14-18 mL, or 15-17 mL per target site.

**[0082]** Other embodiments contemplate administration a total volume of a composition that is in the range of 0.01-30 mL, 0.02-20 mL, 0.03-10 mL of total volume of a composition per target site. Other embodiments contemplate administration of 0.2-500 mL of total solution to a target site, 0.1-0.2 mL total solution to a target site, less than 0.1 mL (optionally excluding 0.03 mL and 0.05 mL per target site).

**[0083]** A unit dose can comprises, consists essentially of, or consists of an amount of the one or more pharmacologically active detergents as disclosed in the compositions herein. A unit dose can further include phospholipids such as phosphatidylcholine at concentrations and units identified in the composition section above. For example, a preferred unit dose has less than 5 g of pharmacologically active detergent (s) and/or less than 5% phospholipids, such as phosphatidylcholine.

**[0084]** In preferred embodiments, a unit dose comprises, consists essentially of, or consists of one or more pharmacologically active detergent(s) in an injectable formulation wherein the unit dose has a total volume of less than 500 mL, but more than 0.2 mL. Such unit dose may have less than 5%, w/w, w/v or v/v phospholipids (e.g., phosphatidylcholine).

**[0085]** In some embodiments, a unit dose comprises of more than 0.1% w/w, w/v or v/v of the one or more detergents herein and the unit dose has a total volume of more than 0.2 mL and less than 500 mL. In some embodiments, a unit dose comprises of more than 0.1% w/w, w/v or v/v of the one or more detergents herein and the unit dose has a total volume of less than 0.1 mL, optionally excluding 0.03 mL and 0.05 mL.

**[0086]** In some embodiments, a unit dose comprises less than 0.01 g of the one or more detergents and has a total volume of less than 500 mL.

**[0087]** For example, in some embodiments, a unit dose comprises of less than 0.1% or 0.01% by weight of the one or more detergents herein.

**[0088]** In some embodiments, a unit dose has less than 0.9% w/w or more than 13% w/w of the one or more detergents herein and has a total volume of 0.1-0.2 mL.

**[0089]** The unit dose will depend, in part, on the target area, amount of fat, and desired result.

**[0090]** Salts and Esters

**[0091]** The present invention also contemplates pharmaceutically acceptable salts and esters of the detergents herein. Such salts and esters are meant to be those salts and esters which are within the scope of sound medical judgment, suitable for use in contact with the tissues of humans and animals without undue toxicity, irritation, allergic response, and the like, commensurate with a reasonable benefit/risk ratio, and effective for their intended use.

**[0092]** Among the more common pharmaceutically acceptable salts and esters are the acetate, estolate (lauryl sulfate salt of the propionate ester), ethyl succinate, gluceptate (glucoheptonate), lactobionate, stearate, and hydrochloride forms. Other acid salts contemplated herein are the following: adipate, alginate, aspartate, benzoate, benzene sulfonate, bisulfate, butyrate, citrate, camphorate, camphorsulfonate, cyclopentanepropionate, digluconate, dodecylsulfate, ethanesulfonate, fumarate, gluconate, glycerophosphate, hemisulfate, heptonate, hexanoate, hydrobromide, hydroiodide, 2-hydroxy ethanesulfonate, lactate, maleate, methane-

sulfonate, 2-naphthalenesulfonate, nicotinate, oxalate, pantothenate, pectinate, persulfate, 3-phenylpropionate, picrate, pivalate, propionate, succinate, tartrate, thiocyanate, tosylate, and undecanoate.

**[0093]** Basic nitrogen-containing groups can be quaternized with such agents as lower alkyl halides, such as methyl, ethyl, propyl and butyl chloride, bromides and iodides; dialkyl sulfates like dimethyl, diethyl, dibutyl, and diamyl sulfates; long chain halides such as decyl, lauryl, myristyl and stearyl chlorides, bromides and iodides; aralkyl halides like benzyl and phenethyl bromides and others.

**[0094]** In preferred embodiments, one or more of the detergents herein are bile salts. Bile salts herein may be formed with inorganic bases, ammonia, organic bases, inorganic acids, organic acids, basic amino acids, halogen ions or the like, and inner salts. Examples of the inorganic base include alkali metal (e.g., Na and K) and alkaline earth metal (e.g., Mg). Examples of the organic base include procaine, 2-phenylethylbenzylamine, dibenzylethylenediamine, etanolamine, di ethanolamine, tris(hydroxymethyl)aminomethane, polyhydroxyalkylamine, and N-methyl glucosamine. Examples of the inorganic acid include hydrochloric acid, hydrobromic acid, sulfuric acid, nitric acid, and phosphoric acid. Examples of the organic acid include p-toluene sulfonic acid, methanesulfonic acid, formic acid, trifluoroacetic acid and maleic acid. Examples of the basic amino acid include lysine, arginine, ornithine and histidine.

**[0095]** Bile acids may be present as their esters, for example, but not limited to, optionally substituted C1-C6 alkyl, C2-C6 alkenyl, C3-C10 cycloalkyl, C3-C10 cycloalkyl (C1-C6)alkyl, optionally substituted C6-C10 aryl, optionally substituted C7-C12 aralkyl, di(C6-C10)arylmethyl, tri(C6-C10)arylmethyl, and substituted silyl.

**[0096]** Examples of the optionally substituted C1-6 alkyl include e.g., methyl, ethyl, n-propyl, n-butyl, t-butyl, n-pentyl, and n-hexyl, each may be substituted with benzyloxy, C1-4 alkylsulfonyl (e.g., methanesulfonyl), trimethylsilyl, halogen (e.g., F, Cl, and Br), acetyl, nitrobenzoyl, mesylbenzoyl, phthalimide, succinoylimide, benzenesulfonyl, phenylthio, di-C1-4alkylamino (e.g., dimethylamino), pyridyl, C1-4alkylsulfanyl (e.g., methanesulfanyl), cyano and the like. Such substituted C1-6 alkyl include e.g., benzyloxymethyl, 2-methanesulfonylethyl, 2-trimethylsilylethyl, 2,2,2-trichloroethyl, 2-iodoethyl, acetylmethyl, p-nitrobenzoylmethyl, p-mesybenzoylmethyl, phthalimidemethyl, succinoylimidemethyl, benzenesulfonylmethyl, phenylthiomethyl, and 1-dimethylaminoethyl. The above C2-6 alkenyl includes e.g., vinyl, aryl, 1-propenyl, isopropenyl, 1-butenyl, 2-butenyl, 1,1-dimethylaryl, 3-methyl and 3-butenyl. The above C3-10 cycloalkyl includes e.g., cyclopropyl, cyclobutyl, cyclopentyl, cyclohexyl, cycloheptyl, norbornyl, and adamantyl. The above C3-10 cycloalkyl(C1-6)alkyl includes e.g., cyclopropylmethyl, cyclopentylmethyl, and cyclohexylmethyl. The above C6-10 aryl includes e.g., phenyl, alpha-naphthyl, 8-naphthyl, and biphenyl, each may be substituted with nitro, halogen (e.g., F, Cl, and Br) or the like, and such substituted aryl includes e.g., p-nitrophenyl and p-chlorophenyl. The above optionally substituted C7-12 aralkyl includes e.g., benzyl, 1-phenylethyl, 2-phenylethyl, phenylpropyl and naphthylmethyl, each may be substituted with nitro, C1-4 alkoxy (e.g., methoxy), C1-4 alkyl (e.g., methyl, ethyl), hydroxy or the like. Such substituted group is exemplified by p-nitrobenzyl, p-methoxybenzyl (PMB), or 3,5-di-t-butyl-4-hydroxybenzyl. The above di(C6-10 aryl)methyl includes benzhydryl

and the C6-10 arylmethyl includes trityl, and the substituted silyl includes trimethylsilyl and tert-butyldimethylsilyl. Examples of the active ester include organic phosphate esters (e.g., diethoxy phosphate ester and diphenoxy phosphate ester), cyanomethyl ester, and the active thioester includes esters formed with aromatic heterocyclicthio compound (e.g., 2-pyridylthio ester).

**[0097]** Examples, of other reactive derivative of bile acids include acid halides, acid azides, acid anhydrides, mixed acid anhydride, active amide, and active thioester. The acid halide includes acid chloride and acid bromide; the mixed acid anhydride includes mixed monoalkylcarboxylic acid anhydride, mixed aliphatic carboxylic acid anhydride, aromatic carboxylic acid anhydride, organic sulfonic acid anhydride, the active amide includes amide formed with heterocyclic compound containing N atom, for example.

**[0098]** Micelles

**[0099]** Detergents, including bile acids, are micelle-forming compounds. It is believed that the presence of the micelles significantly increases the solubility of hydrophobic molecules not ordinarily soluble in water (e.g., the lipids that comprise cell membranes) by burying their hydrophobic portions away from aqueous solvent (e.g., water). As will be appreciated by those skilled in the art, a micelle is a colloidal aggregate of amphipathic molecules in which the polar hydrophilic portions of the molecule extend outwardly while the non-polar hydrophobic portions extend inwardly.

**[0100]** In some embodiments, the present invention contemplates homogenous micelles (micelles produced by a single detergent), while in other embodiments, the present invention contemplates mixed micellar formations (micelles produced by two or more compounds—one of which is a detergent).

**[0101]** In some embodiments, an average particle size of micelles in a composition of the present invention is contemplated to be in the range of 1 nanometer to 100 micrometers, 10 nanometers to 50 micrometers, 100 nanometers to 1 micrometers, etc. Moreover, the shape of the micelle can vary and can be, for example, prolate, oblate or spherical; spherical micelles are most typical.

**[0102]** In some embodiments, at least 10%, 15%, 20%, 25%, 30%, 35%, 40%, 45%, 50%, 55%, 60%, 65%, 70%, 75%, 80%, 85%, 90%, 95%, 99% of the detergent in the compositions herein is in micellar formation. In other embodiments, less than 90%, 80%, 70%, 60%, 50%, 40%, 30%, 20%, 10%, or 5% of the detergent in the compositions herein is in micellar formation. In other embodiments, about 10-90%, 20-80%, 30-70%, 40-60%, or about 50% of the detergent of the compositions herein is in micellar formation.

**[0103]** In some embodiments, an average size of a micelle in a composition of the present invention may be less than  $10^{-5}$ ,  $10^{-6}$ ,  $10^{-7}$ ,  $10^{-8}$ ,  $10^{-9}$ . In some embodiments, an average size of a micelle in a composition of the present invention may be greater than  $10^{-5}$ ,  $10^{-8}$ ,  $10^{-7}$ ,  $10^{-8}$ ,  $10^{-9}$ . In some embodiments, an average size of a micelle in a composition of the present invention may be in the range of  $1 \times 10^{-5}$  to  $9 \times 10^{-5}$ ;  $1 \times 10^{-6}$  to  $9 \times 10^{-8}$ ;  $1 \times 10^{-7}$  to  $9 \times 10^{-7}$ ;  $1 \times 10^{-8}$  to  $9 \times 10^{-8}$ ;  $1 \times 10^{-9}$  to  $9 \times 10^{-9}$ .

**[0104]** In some embodiments, an average molecular weight of a micelle in a composition of the present invention may be less than 100,000 Daltons, 50,000 Daltons, 40,000 Daltons, 30,000 Daltons, 20,000 Daltons, 10,000 Daltons, 9,000 Daltons, 8,000 Daltons, 7,000 Daltons, 6,000 Daltons, 5,000 Daltons, 4,000 Daltons, 3,000 Daltons, 2,000 Daltons, 1,000



Daltons, or 500 Daltons. In some embodiments, an average molecular weight of a micelle in a composition of the present invention may be greater than 500 Daltons, 1,000 Daltons, 1,500 Daltons, 2,000 Daltons, 2,500 Daltons, 3,000 Daltons, 3,500 Daltons, 4,000 Daltons, 4,500 Daltons, 5,000 Daltons, 5,500 Daltons, 6,000 Daltons, 6,500 Daltons, 7,000 Daltons, 7,500 Daltons, 8,000 Daltons, 8,500 Daltons, 9,000 Daltons, 9,500 Daltons, 10,000 Daltons, or 15,000 Daltons. In some embodiments, an average molecular weight of a micelle in a composition of the present invention may be in the range of 100-20,000 Daltons, 1,000-10,000 Daltons, 2,000-1,000 Daltons, or 3,000-5,000 Daltons.

**[0105]** Second Therapeutic Agents

**[0106]** In yet another embodiment of the present invention the compositions herein can be co-formulated, co-administered, and/or co-marketed with a second therapeutic agent.

**[0107]** Non-limiting examples of second therapeutic agents include: anti-microbial agents, vasoconstrictors, anti-thrombotic agents, anti-coagulation agents, suds-depressants, anti-inflammatory agents, analgesics, dispersion agents, anti-dispersion agents, penetration enhancers, steroids, tranquilizers, muscle relaxants, and anti-diarrhea agents.

**[0108]** Anti microbial agents suitable for use with the compositions, methods, and kits herein include, but not limited to, anti-bactericidal agents, anti-fungal agents, anti-viral agents or the like, and are preferably efficacious against a broad spectrum of microbes.

**[0109]** Examples of anti-bacterial agents include, but not limited to, benzalkonium chloride, benzoic acid, benzoxonium chloride, benzyl alcohol, 2-bromo-2-nitropropane-1,3-diol, 5-bromo-5-nitro-1,3-dioxane, bromochlorophene, camphor benzalkonium methosulfate, captan, cetrimonium bromide, cetrimonium chloride, cetylpyridinium chloride, climbazol, chloracetamide, chlorhexidine and its salts, p-chloro-m-cresol, chlorphenesin, chloroxylenol, chlorophen, chlorobutanol, o-cymen-5-ol, dehydroacetic acid, dibromodicyanobutan, dibromohexamidin, dibromopropamidin, dichlorobenzyl alcohol, dichlorophenyl imidazolidioxolan, dimethyloxazolidin, DMDM hydantoin, dodecylguanidine acetate, hexamidine diisothionate, hexachlorophen, hexetidin, iodopropynyl butylcarbamate, lauryl isoquinolinium bromide, methylidibromo glutaronitrile, methylolchloracetamide, phenethyl alcohol, phenoxyethanol, phenoxypropanol, o-phenylphenol, piroctone olamine, polyaminopropyl biguanide, potassium sorbate, potassium undecylenoyl hydrolyzed collagen, quaternium-15, salicylic acid, sodium benzoate, sodium dehydroacetate, sodium hydroxymethylglycinate, sodium o-phenylphenate, sorbic acid, triclocarban, triclosan, undecylenic acid and its derivatives, zinc cysteate, zinc gluconate, zinc pyrithione, or zinc sulfate. Derivatives of undecylenic acid useful as antimicrobial agents are e.g. esters, such as methyl ester, isopropyl ester, glyceryl ester, ethoxylated soya sterol ester, or ethoxylated PHB ester, or amides, such as monoethanolamide, monoethanolamide derivatives such as monoethanolamide (MEA) sulfosuccinate salts, diethanolamide, protein condensates, e.g. potassium undecylenoyl hydrolyzed animal collagen, and quaternized 3-aminopropyl-amide, e.g. undecylenamidopropyltrimonium methosulfate. Specific examples of suitable fungicidal/fungistatic agents include, without limitation, dithiocarbamates, phthalimides, dicarboximides, organophosphates, benzimidazoles, carboxanilides, phenylamides, phosphites, and the like.

**[0110]** Other examples of anti-bacterial agents include, but are not limited to, erythromycin, clarithromycin, penicillins, cephalosporins, aminoglycosides, sulfonamides, macrolides, tetracyclins, lincosides, quinolones, chloramphenicol, vancomycin, metronidazole, rifampin, isoniazid, spectinomycin, trimethoprim, sulfamethoxazole, penems, carbapenems, monobactams mupirocin, neomycin sulfate bacitracin, polymyxin B, 1-ofloxacin, tetracyclines (chlortetracycline hydrochloride, oxytetracycline hydrochloride and tetracycline hydrochloride), clindamycin phosphate, gentamicin sulfate, benzalkonium chloride, benzethonium chloride, hexylresorcinol, methylbenzethonium chloride, phenol, quaternary ammonium compounds, triclocarbon, triclosan, tea tree oil, and their pharmaceutically acceptable salts, and the pharmaceutically acceptable salts and esters thereof.

**[0111]** Other examples of anti-bacterial agents include, but are not limited to, Acrofloxacina, Amoxicillin plus clavulonic acid (i.e. Augmentin), Amikacin, Ampicillin, Apalcillin, Apramycin, Astromicin, Arbekacin, Aspoxicillin, Azidozillin, Azithromycin, Azlocillin, Bacitracin, Benzathine penicillin, Benzylpenicillin, Carbencillin, Cefaclor, Cefadroxil, Cefalexin, Cefamandole, Cefaparin, Cefatrizine, Cefazolin, Cefbuparazone, Cefcapene, Cefdinir, Cefditoren, Cefepime, Cefetamet, Cefixime, Cefmetazole, Cefminox, Cefoperazone, Ceforanide, Cefotaxime, Cefotetan, Cefotiam, Cefoxitin, Cefpimizole, Cefpiramide, Cefpodoxime, Cefprozil, Cefradine, Cefroxadine, Cefsulodin, Ceftazidime, Ceftriaxone, Cefuroxime, Chloramphenicol, Chlortetracycline, Ciclacillin, Cinoxacin, Ciprofloxacina, Clarithromycin, Clemizole penicillin, Clindamycin, Cloxacillin, Daptomycin, Demeclocycline, Desquinoxolone, Dibekacin, Dicloxacillin, Dirithromycin, Doxycycline, Enoxacin, Epicillin, Erythromycin, Ethambutol, Fleroxacin, Flomoxef, Flucloxacillin, Flumequine, Flurithromycin, Fosfomicin, Fosmidomycin, Fusidic acid, Gatifloxacina, Gemifloxacina, Gentamicin, Imipenem, Imipenem plus Cilistatin combination, Isepamicin, Isoniazid, Josamycin, Kanamycin, Kasugamycin, Kitasamycin, Latamoxef, Levofloxacina, Lincomycin, Linezolid, Lomefloxacina, Loracarbarf, Lyme cycline, Mecillinam, Meropenem, Methacycline, Methicillin, Metronidazole, Mezlocillin, Midecamycin, Minocycline, Miokamycin, Moxifloxacina, Nafcillin, Nafceillin, Nalidixic acid, Neomycin, Netilmicin, Norfloxacina, Novobiocin, Ofloxacina, Oleanomycin, Oxacillin, Oxolinic acid, Oxytetracycline, Paromycin, Pazufloxacina, Pefloxacina, Penicillin G, Penicillin V, Phenethicillin, Phenoxyethyl penicillin, Pipemidic acid, Piperacillin, Piperacillin and Tazobactam combination, Piroimidic acid, Procaine penicillin, Propicillin, Pyrimethamine, Rifabutin, Rifamide, Rifampicin, Rifamycin SV, Rifapentene, Rokitamycin, Rolitetracycline, Roxithromycin, Rulofloxacina, Sitafloxacina, Sparfloxacina, Spectinomycin, Spiramicin, Sulfadiazine, Sulfadoxine, Sulfamethoxazole, Sisomicin, Streptomycin, Sulfamethoxazole, Sulfisoxazole, Synercid (Quinupristan-Dalfopristan combination), Teicoplanin, Telithromycin, Temocillin, Tetracycline, Tetroxoprim, Thiamphenicol, Ticarcillin, Tigecycline, Tobramycin, Tosufloxacina, Trimethoprim, Trimetrexate, Trovafloxacina, Vancomycin, and Verdamicin.

**[0112]** Vasoconstrictor agents suitable for use with the compositions of the present invention can include, for example, dihydroergotamine, ergotamine and methysergide, pharmaceutically-acceptable salts thereof,

**[0113]** Anti-thrombotic agents suitable for use with the compositions of the present invention can include, for

example, argatroban, iloprost, lamifiban, taprostene, tirofiban, tissue plasminogen activator (natural or recombinant), tenecteplase (TNK), and lanoteplase (nPA); factor VIIa inhibitors; factor Xa inhibitors; thrombin inhibitors (such as hirudin and argatroban); PAI-1 inhibitors (i.e., inactivators of tissue plasminogen activator inhibitors); alpha2-antiplasmin inhibitors; streptokinase, urokinase and prourokinase; and anisoylated plasminogen streptokinase activator complex. anti-coagulants (e.g. hirudin, heparin, etc.), plasminogen activators (e.g. t-PA, urokinase, etc.), fibrinolytic enzymes (e.g. plasmin, subtilisin, etc.), anti-platelet-aggregation agents (e.g. prostacyclin, aspirin, etc.) and the like.

**[0114]** Anti-coagulation agents suitable for use with the compositions of the present invention can include, for example, cilostazol (PLETAL®, Otsuka), clopidogrel (PLAVIX®, Sanofi), ticlopidine (TICLID®, Syntex), tirofiban (AGGRASTAT®, Merck), eptifibatide (INTEGRILIN®, COR Therapeutics), abciximab (REOPRO®, Eli Lilly), anagrelide (AGRYLIN®, Roberts), dipyridamole (PERSANTIN®, Boehringer Ingelheim), aspirin (ECOTR®, and others), dipyridamole/aspirin (AGGRENOLX®, Boehringer Ingelheim), dalteparin (FRAGMIN®, Pharmacia), enoxaparin (LOVENOX®, Aventis), tinzaparin (INNOHE®, DuPont), heparin (various), danaparoid (ORGANON®, Organon), antithrombin III (THROMBATE®, Bayer), lepirudin (REFLUDAN®, Hoechst-Marion Roussel), argatroban (ACOVA®, SmithKlineBeecham), bivalirudin (ANGIOMAX®, Medicines Company), warfarin (COUMADIN®, DuPont) anisidione (MIRADON®, Schering), alteplase (ACTIVASE®, Genentech), reteplase (RETAVASE®, Boehringer Mannheim), tenecteplase (TNKASE®, Genentech), drotrecogin (XIGRIS®, Eli Lilly), anistreplase (EMINASE®, Roberts), streptokinase (STREPTASE®, Astra), urokinase (ABBOKINASE®, Abbott) and combinations thereof.

**[0115]** Suds-depressants suitable for use with the compositions, methods and kits of the present invention can include, for example, monocarboxylic fatty acid and soluble salts thereof. The monocarboxylic fatty acids and salts thereof used as suds suppressor may have hydrocarbyl chains of 1 to about 50 carbon atoms, about 10 to about 24 carbon atoms, or about 12 to about 18 carbon atoms. Suitable salts include the alkali metal salts such as sodium, potassium, and lithium salts, and ammonium and alkanolammonium salts. Additional suds-depressants include, for example, high molecular weight hydrocarbons such as paraffin, fatty acid esters (e.g., fatty acid triglycerides), fatty acid esters of monovalent alcohols, aliphatic C<sub>18</sub>-C<sub>40</sub> ketones (e.g., stearone), etc. Other suds-depressants include N-alkylated amino triazines such as tri- to hexa-alkylmelamines or di- to tetra-alkyldiamine chlorotriazines formed as products of cyanuric chloride with two or three moles of a primary or secondary amine containing 1 to 24 carbon atoms, propylene oxide, and monostearyl phosphates such as monostearyl alcohol phosphate ester and monostearyl di-alkali metal (e.g., K, Na, and Li) phosphates and phosphate esters. The hydrocarbons such as paraffin and haloparaffin can be utilized in liquid form. It is also known to utilize waxy hydrocarbons, preferably having a melting point below about 100° C. The hydrocarbons constitute a preferred category of suds suppressor for detergent compositions. The hydrocarbons, thus, include aliphatic, alicyclic, aromatic, and heterocyclic saturated or unsaturated hydrocarbons having from about 12 to about 70 carbon atoms. The term "paraffin,"

as used in this suds suppressor discussion, is intended to include mixtures of true paraffins and cyclic hydrocarbons.

**[0116]** Another example of suds suppressors comprises silicone suds suppressors. This category includes the use of polyorganosiloxane oils, such as polydimethylsiloxane, dispersions or emulsions of polyorganosiloxane oils or resins, and combinations of polyorganosiloxane with silica particles wherein the polyorganosiloxane is chemisorbed or fused onto the silica. Examples also include, but not limited to, silicones, and silica-silicone mixtures. Silicones can be generally represented by alkylated polysiloxane materials while silica is normally used in finely divided forms exemplified by silica aerogels and xerogels and hydrophobic silicas of various types. Silicone suds controlling agent, DC-544, is commercially available from Dow Corning, which is a siloxane-glycol copolymer. Other preferred suds controlling agent are the suds suppressor system comprising a mixture of silicone oils and 2-alkyl-alkanols. Suitable 2-alkyl-alkanols are 2-butyl-octanol which are commercially available under the trade name Isofol 12™ and silicone/silica mixture in combination with fumed nonporous silica such as Aerosil™.

**[0117]** Examples of anti-dispersion agents include, but are not limited to, sucrose, glycerol, and glycerin.

**[0118]** Steroids suitable for use with the compositions of the present invention can include, for example, betamethasone, chlorprednisone, clocortolone, cortisone, desonide, dexamethasone, desoximetasone, difluprednate, estradiol, fludrocortisone, flumethasone, flunisolide, fluocortolone, fluprednisolone, hydrocortisone, meprednisone, methylprednisolone, paramethasone, prednisolone, prednisone, pregnan-3-alpha-ol-20-one, testosterone, and triamcinolone. estradiol, estron, estriol, polyestradiol, polyestriol, dienes-trol, diethylstilbestrol, dihydroergosterone, cyproterone, danazol, testosterone, progesterone, norethindrone, levonorgestrol, ethynodiol, norgestimate, gestanin, 3-keton-desogestrel, demegestone, promethoestrol, testosterone, spironolactone, and esters thereof, budesonide, rofleponide, rofleponide palmitate, ciclesonide, mometasone furoate, fluticasone propionate, tipredane, fluocinolone acetonide, flunisolide, flumethasone, dexamethasone, beclomethasone dipropionate, deflazacort, cortivazol, or cortisol and/or hydrocortisol, prednisone, fluorometholone acetate, dexamethasone sodium phosphate, suprofen, fluorometholone, and medrysone, optionally in their pure isomeric forms (where such forms exist) and in the forms of their pharmaceutically acceptable salts.

**[0119]** Anti-inflammatory agents suitable for use with the compositions of the present invention can include both steroidal anti-inflammatory agents and non-steroidal anti-inflammatory agents. Suitable steroidal anti-inflammatory agent can include, although are not limited to, corticosteroids such as hydrocortisone, hydroxyltriamcinolone alphanemethyl dexamethasone, dexamethasone-phosphate, beclomethasone dipropionate, clobetasol valerate, desonide, desoxymethasone, desoxycorticosterone acetate, dexamethasone, dichlorisone, diflorasone diacetate, diflucortolone valerate, fludrenolone, fluclarolone acetonide, fludrocortisone, flumethasone pivalate, fluosinolone acetonide, fluocinonide, flucortine butylester, fluocortolone, fluprednidene (fluprednylidene)acetate, flurandrenolone, halcinonide, hydrocortisone acetate, hydrocortisone butyrate, methylprednisolone, triamcinolone acetonide, cortisone, cortodoxone, flucetonide, fludrocortisone, difluorosone diacetate, fluradrenalone acetonide, medrysone, amciafel, amcinafide, betametha-

sone and the balance of its esters, chlorprednisone, chlorprednisone acetate, clocortelone, clescinolone, dichlorisone, difluprednate, flucoronide, flunisolide, fluoromethalone, fluperolone, fluprednisolone, hydrocortisone valerate, hydrocortisone cyclopentylpropionate, hydrocortamate, meprednisone, paramethasone, prednisolone, prednisone, beclomethasone dipropionate, betamethasone dipropionate, triamcinolone, and mixtures thereof can be used.

**[0120]** A second class of anti-inflammatory agents which is useful in the compositions of the present invention includes the nonsteroidal anti-inflammatory agents. A variety of compounds encompassed by this group are well-known to those skilled in the art. Suitable non-steroidal anti-inflammatory agents useful in the compositions of the present invention include, but are not limited to: the oxicams, such as piroxicam, isoxicam, tonexicam, sudoxicam, and CP-14,304; the salicylates, such as salicylic acid, aspirin, disalcid, benorylate, trilsate, safapryn, solprin, diflunisal, and fendosal; the acetic acid derivatives, such as diclofenac, fenclofenac, indomethacin, sulindac, tolmetin, isoxepac, furofenac, tiopinac, zidometacin, acematacin, fentiazac, zomepiract, clidac, oxeprinac, and felbinac; the fenamates, such as mefenamic, meclofenamic, flufenamic, niflumic, and tolfenamic acids; the propionic acid derivatives, such as ibuprofen, naproxen, benoxaprofen, flurbiprofen, ketoprofen, fenoprofen, fenbufen, indoprofen, piroprofen, carprofen, oxaprozin, pranoprofen, miroprofen, tiroxaprofen, suprofen, alminoprofen, and tiaprofenic; and the pyrazoles, such as phenylbutazone, oxyphenbutazone, feprazone, azapropazone, and trimethazone. Mixtures of these nonsteroidal anti-inflammatory agents can also be employed, as well as the pharmaceutically-acceptable salts and esters of these agents.

**[0121]** Analgesics suitable for use with the pharmacologically active detergent composition of the present invention to reduce discomfort due to inflammation after subcutaneous injection of the formulation of the present invention include, but are not limited to, injectable local amine and ester anesthetics. Non-limiting examples of analgesics include lidocaine, mepivacaine, bupivacaine, procaine, chlorprocaine, etidocaine, prilocaine dyclonine, hexylcaine, procaine, cocaine, ketamine, pramoxine, propophol, phenol and tetracaine. Mixtures of these analgesics can also be employed, as well as the pharmaceutically acceptable salts and esters or these agents. Other examples of analgesics include opioids. Examples of opioids include morphine, or a salt thereof, such as the sulphate, chloride, or hydrochloride. Other 1,4-hydroxymorphinan opioid analgesics that may be used herein include those such as naloxone, meperidine, butorphanol or pentazocine, or morphine-6-glucuronide, codeine, dihydrocodeine, diamorphine, dextropropoxyphene, pethidine, fentanyl, alfentanil, alphaprodine, buprenorphine, dextromoramide, diphenoxylate, dipipanone, heroin (diacetylmorphine), hydrocodone (dihydrocodeinone), hydromorphone (dihydromorphinone), levorphanol, meptazinol, methadone, metopon (methyldihydromorphinone), nalbuphine, oxycodone (dihydrohydroxycodone), oxymorphone (dihydrohydroxymorphinone), phenadoxone, phenazocine, remifentanyl, tramadol, or a salt of any of these. The opioid used in the method of the invention may comprise any combination of the aforementioned compounds. Naloxone is also included within the definition of an opioid. Especially preferred analgesics which may be use include hydromorphone, oxyc-

odone, morphine, e.g. morphine sulphate and fentanyl and/or pharmaceutically-acceptable salts thereof.

**[0122]** Suitable tranquilizer and sedative drugs that may be included in the kits or compositions of the present invention include chlordiazepoxide, benactyzine, benzquinamide, flurazepam, hydroxyzine, loxapine, promazine, and/or acceptable salts and esters thereof.

**[0123]** Suitable muscle relaxant drugs that may be included in the kits or compositions of the present invention include cinnamedrine, cyclobenzaprine, flavoxate, orphenadrine, papaverine, mebeverine, idaverine, ritodrine, depheoxylate, dantrolene, azumolene, and/or pharmaceutically-acceptable salts thereof.

**[0124]** Suitable anti-diarrhea drugs may be included in the kits or compositions of the present invention include, for example, loperamide, and/or pharmaceutically-acceptable salts thereof.

**[0125]** Second therapeutic agents may be co-formulated and/or co-administered with the one or more pharmacologically active detergents herein. In such co-formulations, a second therapeutic agent may be at a concentration of less than 20%, 19%, 18%, 17%, 16%, 15%, 14%, 13%, 12%, 11%, 10%, 9%, 8%, 7%, 6%, 5%, 4%, 3%, 2%, 1%, 0.5%, 0.4%, 0.3%, 0.2%, 0.1%, 0.09%, 0.08%, 0.07%, 0.06%, 0.05%, 0.04%, 0.03%, 0.02%, 0.01%, 0.009%, 0.008%, 0.007%, 0.006%, 0.005%, 0.004%, 0.003%, 0.002%, 0.001%, 0.0009%, 0.0008%, 0.0007%, 0.0006%, 0.0005%, 0.0004%, 0.0003%, 0.0002%, or 0.0001% w/w, w/v or v/v.

**[0126]** In some embodiments, a second therapeutic agent may be co-formulated with the one or more pharmacologically active detergents herein. In such co-formulation, the second therapeutic agent may be at a concentration greater than 20%, 19.75%, 19.50%, 19.25% 19%, 18.75%, 18.50%, 18.25% 18%, 17.75%, 17.50%, 17.25% 17%, 16.75%, 16.50%, 16.25% 16%, 15.75%, 15.50%, 15.25% 15%, 14.75%, 14.50%, 14.25% 14%, 13.75%, 13.50%, 13.25% 13%, 12.75%, 12.50%, 12.25% 12%, 11.75%, 11.50%, 11.25% 11%, 10.75%, 10.50%, 10.25% 10%, 9.75%, 9.50%, 9.25% 9%, 8.75%, 8.50%, 8.25% 8%, 7.75%, 7.50%, 7.25% 7%, 6.75%, 6.50%, 6.25% 6%, 5.75%, 5.50%, 5.25% 5%, 4.75%, 4.50%, 4.25%, 4%, 3.75%, 3.50%, 3.25%, 3%, 2.75%, 2.50%, 2.25%, 2%, 1.75%, 1.50%, 1.25%, 1%, 0.5%, 0.4%, 0.3%, 0.2%, 0.1%, 0.09%, 0.08%, 0.07%, 0.06%, 0.05%, 0.04%, 0.03%, 0.02%, 0.01%, 0.009%, 0.008%, 0.007%, 0.006%, 0.005%, 0.004%, 0.003%, 0.002%, 0.001%, 0.0009%, 0.0008%, 0.0007%, 0.0006%, 0.0005%, 0.0004%, 0.0003%, 0.0002%, or 0.0001% w/w, w/v or v/v.

**[0127]** In some embodiments, a second therapeutic agent may be co-formulated with the one or more pharmacologically active detergents herein such that the final formulation has a concentration of the second therapeutic agent that is in the range of from approximately 0.001% to approximately 50%, approximately 0.001% to approximately 40%, approximately 0.01% to approximately 30%, approximately 0.02% to approximately 29%, approximately 0.03% to approximately 28%, approximately 0.04% to approximately 27%, approximately 0.05% to approximately 26%, approximately 0.06% to approximately 25%, approximately 0.07% to approximately 24%, approximately 0.08% to approximately 23%, approximately 0.09% to approximately 22%, approximately 0.1% to approximately 21%, approximately 0.2% to approximately 20%, approximately 0.3% to approximately 19%, approximately 0.4% to approximately 18%, approximately 0.5% to approximately 17%, approximately 0.6% to

approximately 16%, approximately 0.7% to approximately 15%, approximately 0.8% to approximately 14%, approximately 0.9% to approximately 12%, approximately 1% to approximately 10% w/w, w/v or v/v. It is understood that the final concentration is dependent on many factors known to persons skilled in the art including, but not limited to, location and size of the treatment site.

**[0128]** In some embodiments, a composition herein comprises, consists essentially of, or consists of less than 10 g, 9.5 g, 9.0 g, 8.5 g, 8.0 g, 7.5 g, 7.0 g, 6.5 g, 6.0 g, 5.5 g, 5.0 g, 4.5 g, 4.0 g, 3.5 g, 3.0 g, 2.5 g, 2.0 g, 1.5 g, 1.0 g, 0.95 g, 0.9 g, 0.85 g, 0.8 g, 0.75 g, 0.7 g, 0.65 g, 0.6 g, 0.55 g, 0.5 g, 0.45 g, 0.4 g, 0.35 g, 0.3 g, 0.25 g, 0.2 g, 0.15 g, 0.1 g, 0.09 g, 0.08 g, 0.07 g, 0.06 g, 0.05 g, 0.04 g, 0.03 g, 0.02 g, 0.01 g, 0.009 g, 0.008 g, 0.007 g, 0.006 g, 0.005 g, 0.004 g, 0.003 g, 0.002 g, 0.001 g, 0.0009 g, 0.0008 g, 0.0007 g, 0.0006 g, 0.0005 g, 0.0004 g, 0.0003 g, 0.0002 g, or 0.0001 g of the one or more second therapeutic agents herein.

**[0129]** In some embodiments, a composition herein comprises, consists essentially of, or consists of more than 0.0001 g, 0.0002 g, 0.0003 g, 0.0004 g, 0.0005 g, 0.0006 g, 0.0007 g, 0.0008 g, 0.0009 g, 0.001 g, 0.0015 g, 0.002 g, 0.0025 g, 0.003 g, 0.0035 g, 0.004 g, 0.0045 g, 0.005 g, 0.0055 g, 0.006 g, 0.0065 g, 0.007 g, 0.0075 g, 0.008 g, 0.0085 g, 0.009 g, 0.0095 g, 0.01 g, 0.015 g, 0.02 g, 0.025 g, 0.03 g, 0.035 g, 0.04 g, 0.045 g, 0.05 g, 0.055 g, 0.06 g, 0.065 g, 0.07 g, 0.075 g, 0.08 g, 0.085 g, 0.09 g, 0.095 g, 0.1 g, 0.15 g, 0.2 g, 0.25 g, 0.3 g, 0.35 g, 0.4 g, 0.45 g, 0.5 g, 0.55 g, 0.6 g, 0.65 g, 0.7 g, 0.75 g, 0.8 g, 0.85 g, 0.9 g, 0.95 g, 1 g, 1.5 g, 2 g, 2.5 g, 3 g, 3.5 g, 4 g, 4.5 g, 5 g, 5.5 g, 6 g, 6.5 g, 7 g, 7.5 g, 8 g, 8.5 g, 9 g, 9.5 g, or 10 g of the one or more second therapeutic agents herein.

**[0130]** In some embodiments, a composition herein comprises, consists essentially of, or consists of 0.0001-10 g, 0.0005-9 g, 0.001-8 g, 0.005-7 g, 0.01-6 g, 0.05-5 g, 0.1-4 g, 0.5-4 g, or 1-3 g of the one or more second therapeutic agents herein.

**[0131]** Pharmaceutical Formulations

**[0132]** Pharmacologically acceptable aqueous vehicles for the compositions of the present invention can include, for example, any liquid solution that is capable of dissolving a detergent and is not toxic to the particular individual receiving the formulation. Examples of pharmaceutically acceptable aqueous vehicles include, without limitation, saline, water and acetic acid. Typically, pharmaceutically acceptable aqueous vehicles are sterile.

**[0133]** Pharmacologically active detergent compositions useful in embodiments of the present invention are formulated for the non-surgical reduction of localized fat deposits. As used herein, "non-surgical" refers to medical procedures that do not require an incision. Injections are examples of non-surgical procedures. Liposuction is a surgical procedure.

**[0134]** In one embodiment of the present invention, the pharmacologically active detergent composition is administered by injection, for example, by bolus injection. In order to be effective, the detergent composition must have direct contact with the fat tissue regardless of how it is infused. The detergent formulations can be injected subcutaneously or infused directly into the fat. Formulations for injection can be presented in unit dosage form, for example, in ampoules or in multi-dose containers, with an added preservative. The compositions can take such forms as suspensions, solutions, or emulsions in oily or aqueous vehicles, and can contain formulatory agents such as suspending, stabilizing and/or dispersing agents.

**[0135]** A "pharmaceutically acceptable excipient" may be used herein, and refers to a compound that is useful in preparing a pharmaceutical composition that is generally safe, non-toxic and neither biologically nor otherwise undesirable, and includes excipients that are acceptable for veterinary use or human pharmaceutical use. A pharmaceutically acceptable excipient as used in the specification and claims includes both one and more than one such excipient. Some examples of suitable excipients include lactose, dextrose, sucrose, sorbitol, mannitol, starches, gum acacia, calcium phosphate, alginates, tragacanth, gelatin, calcium silicate, microcrystalline cellulose, polyvinylpyrrolidone, phosphatidylcholine, cellulose, sterile water, syrup, and methyl cellulose. The formulations can additionally include: lubricating agents such as talc, magnesium stearate, and mineral oil; wetting agents; emulsifying and suspending agents; and preserving agents such as methyl- and propylhydroxy-benzoates and benzyl alcohol. The compositions of the present invention can be formulated so as to provide quick, sustained or delayed release of the active ingredient after administration to the patient by employing procedures known in the art.

**[0136]** Additional excipients suitable for formulation with the detergent compositions of the present invention include penetration enhancers and dispersion agents. Non-limiting examples of dispersion agents which allow the dispersion of drugs in tissue include hyaluronidase and collagenase. Hyaluronidase functions to augment tissue permeability and spread or dispersion of other drugs. Collagenase has been used to isolate adipocytes from subcutaneous fat and does not have lytic effects on adipocytes themselves. Additionally hyaluronidase and collagenase can facilitate healing by accelerating reduction of necrotic tissue after treatment with the detergent formulations of the present invention.

**[0137]** The pharmacologically active detergent compositions of the present invention are useful for treating localized fat accumulations, including but not limited to lower eyelid fat herniation, accumulations on the waist, hips and other cosmetic areas, xanthelasma, lipomas and lipodystrophy, including "buffalo hump" lipodystrophy (3). In another embodiment, the detergent compositions of the present invention is useful for treating fat deposits associated with cellulite.

**[0138]** Methods

**[0139]** The present invention also relates to methods for reducing a subcutaneous fat deposit in a mammal. Such methods comprise, consist essentially of, or consist of administering locally to the fat deposit in the mammal one or more of the compositions or dose units herein. For example, in one embodiment less than 500 mL of a solution is delivered locally to the fat deposit to be reduced. The solution comprises, consists essentially of, or consists of pharmacologically active detergent(s) (preferably bile salts such as sodium deoxycholate), such as those disclosed herein. The solution preferably comprises less than 5% w/v phosphatidylcholine or more preferably comprises no phosphatidylcholine.

**[0140]** In some embodiments of the present invention, the above methods are provided for the non-surgical removal of one or more localized fat deposits in a patient. For example, in one embodiment, the non-surgical methods herein do not include liposuction. In some embodiments, the methods herein also exclude non-invasive means for reducing fat, e.g., ultrasonification. In other embodiments, non-invasive means can be used in conjunction with the compositions herein.

**[0141]** The patient being treated is preferably a mammal. Such mammal can be a human or an animal such as a primate

(e.g., a monkey, chimpanzee, etc.), a domesticated animal (e.g., a dog, cat, horse, etc.), farm animal (e.g., goat, sheep, pig, cattle, etc.), or laboratory animal (e.g., mouse, rat, etc.). Preferably, a patient being treated is a human, a horse, a dog, or a cat.

**[0142]** The compositions herein can be used to treat any adipose condition in the patient including, for example, disorders such as lipomas, herniation, Dercum's disease, Madelung's neck, lipedema, piezogenic nodules, xanthelasma, lipodystrophy, and cellulite. In other embodiments, the compositions herein can be used to treat adipose conditions in areas such as fat deposits localized under eye, under chin, under arm, buttock, calf, back, thigh, ankle, or stomach of a mammal.

**[0143]** The fat-solubilizing compositions herein are preferably administered via a localized injection. However, other means of administering the compositions herein are also contemplated. For example, the compositions herein may be administered via a dermal patch or a subcutaneous depot.

**[0144]** Generally, the total volume, unit dose and number of treatments administered will vary depending on the amount of fat in a target site, the location of the target site, type of fat composition, and desired results. In general, the greater the amount of fat being treated, the greater the dose that is administered. It should be noted that while the compositions and unit dosages herein may be administered into an individual as part of a treatment regimen, they are not removed from the individual as part of the treatment regimen.

**[0145]** Thus, the present invention contemplates methods for reducing amount of subcutaneous fat in a mammal by administering to the mammal an effective amount of a fat-solubilizing composition that comprises, consists essentially of, or consists of one or more pharmacologically active detergents. The above is preferably administered transdermally or subcutaneously, via e.g., a subcutaneous injection using a syringe to a target site. A target site can be for example 0.1 cm $\times$ 0.1 cm, to about 5 cm $\times$ 5 cm. The compositions herein may be administered at the same, adjacent, or nearby target sites at various intervals, dosages, volumes, as disclosed herein.

**[0146]** The present invention provides compositions and methods for the non-surgical reduction of localized fat deposits in a mammal. In one embodiment, the methods herein involve administration of fat-solubilizing concentrations one or more pharmacologically active detergents in pharmaceutically acceptable injectable solutions. For the purposes of the present invention, a non-surgical method of fat reduction does not include liposuction, lipoplasty or suction lipectomy.

**[0147]** Preferably, the methods herein exclude the non active removal of the pharmacologically active detergents (e.g., via suction).

**[0148]** Any of the above methods may be supplemented by further administering to the patient a second therapeutic agent. The second therapeutic agent can be administered separately or in combination with the compositions herein. The second therapeutic agent can be administered locally or systemically. In some embodiments, the second therapeutic agent is co-formulated with the detergent(s) and administered simultaneously with the detergent(s) herein. In other one or more of the second therapeutic agents are administered prior to the administration of the detergents herein.

**[0149]** The above may be administered once or multiple times into the target site. In some embodiments, the compositions herein are administered at least 1, 2, 3, 4, 5, 6, 7, 8, 9,

or 10 times to a target site. More than 1 administration can occur in a single hour, day, week, month, or year. Preferably, multiple administrations into a single target site occur less than 10, 9, 8, 7, 6, 5, 4, 3, or two times a year, less than 10, 9, 8, 7, 6, 5, 4, 3, or 2 times month, less than 10, 9, 8, 7, 6, 5, 4, 3, or two times a week, less than 10, 9, 8, 7, 6, 5, 4, 3, or two times a day or less than 10, 9, 8, 7, 6, 5, 4, 3, or two times an hour. In some embodiments a patient is given 1-100, 2-50, 3-30, 4-20, or 5-10 injection at a target site. This number of injections can occur over a period of 1 year, 6 months, 5 months, 4 months, 3 months, 2 months, 1 month, 3 weeks, 2, weeks, or 1 week or less.

**[0150]** The compositions can be administered at various levels below the dermis, including, for example, 0.1-4 inches, 0.5-3 inches, 1-2 inches below the dermis.

**[0151]** The compositions can be administered in various volumes but preferably in a total volume of less than 50 mL, 40 mL, 30 mL, 20 mL, 10 mL, 9 mL, 8 mL, 7 mL, 6 mL, 5 mL, 4 mL, 3 mL, 2 mL, 1 mL, 0.1 mL, 0.01 mL per injection.

**[0152]** Kits

**[0153]** FIG. 7 is an illustration of a kit **101** for the reduction of subcutaneous fat accumulation in a mammal without the use of liposuction. The kit includes one or more first containers **102**. A first container **102** comprises, consists essentially of, or consists of any of the compositions herein. For example, a first container can comprise, consist essentially of, or consist of a pharmacologically active detergent and less than 5% w/v phosphatidylcholine.

**[0154]** The above may be prepared in a solution or more preferably in an injectable solution. First container(s) **102** comprising such a solution may have sufficient volume to hold one or more unit doses. For example, a first container **102** may be adapted to hold a less than 500 mL, 100 mL solution, 20 mL solution 10 mL solution or 5 mL solution. In some embodiments, first container(s) **102** hold a volume of about 0.01 ml to about 100 ml, about 0.1 ml to about 90 ml, about 0.5 ml to about 80 ml, about 1 ml to about 70 ml, about 2 ml to about 60 ml, about 3 ml to about 50 ml, about 4 ml to about 40 ml, about 5 ml to about 30 ml, about 6 ml to about 20 ml, and about 7 ml to about 10 ml. In more preferred embodiments, the first container(s) **102** is an ampule having a volume capacity of about 10 to about 20 ml.

**[0155]** In some embodiments, the detergent and option phosphatidylcholine are formulated in a dermal patch or a depot for sustained release. Dosages in a patch or depot can be the same as those discussed herein.

**[0156]** A first container **102** can optionally include one or more second therapeutic agents. Preferably, a first container **102** includes an analgesic, antimicrobial agent, or anti-inflammatory agents. A first container **102** can also include a second detergent. Examples of detergents are described herein.

**[0157]** A first container **102** preferably has less than 5% w/v of phospholipids, such as phosphatidylcholine. In some embodiments, a first container **102** contains no phospholipids or no phosphatidylcholine.

**[0158]** A first container **102** preferably has more than 0.01%, 0.1%, 1.0%, 2.0%, 3.0%, 4.0%, or 5.0% w/w, w/v or w/v pharmacologically active detergent(s). Preferably, the concentration of the pharmacologically active detergent in the first container **102** is above its micellar concentration. In some embodiments, the concentration of said pharmacologi-

cally active detergent(s) in % w/v is greater than the concentration of said phospholipids or phosphatidylcholine in % w/v.

[0159] The solution of container 102 is administered according to the instructions for use 103. Instructions for use 103 can provide dosing instructions which may depend upon, for example, target site, mammal being treated, desired results, location of target site, concentration of solution, size of fat deposition. Preferably instructions for use 103 are for the treatment of a mammal such as a human, a dog, a cat, or a horse. Instructions for use 103 can also include information for treatment of other domesticated animals and/or farm animals.

[0160] Instruction for use 103 may also include information on the use of the compositions herein to treat specific target sites, such as, e.g., fat deposits localized under eye, under chin, under arm, buttock, calf, back, thigh, ankle, or stomach of a mammal. In some embodiments, instruction for use 103 detail an explanation for use of the compositions herein to treat a fat deposit that is eyelid fat herniation, lipomas, lipodystrophy, buffalo hump lipodystrophy or fat deposits associated with cellulite.

[0161] Instruction for use 103 may include information regarding proper diluents and volumes for dilution, if any, of the first container 102 and/or the second container 105. The instructions for use 103 may also provide information regarding the proper administration of the compositions herein, such as frequency and dosage of administration.

[0162] Kit 101 may further comprise a syringe or other suitable delivery device (e.g., patch, subcutaneous depot) 104 for delivering the compositions in first container 102 to a subcutaneous fat accumulation region. In some embodiments, syringe or delivery device 104 may be preloaded with a unit dose of a solution of the present invention.

[0163] The kit 101 may further include a second container 105 comprising a second active agent. Examples of a second therapeutic agent include, for example, an antimicrobial agent, an anti-thrombotic agent, an anti-coagulation agent, a suds-depressant, an anti-inflammatory agent, an analgesic, an anesthetic, an anti-dispersion agent, a dispersion agent, a penetration enhancer, a steroid, a tranquilizer, a muscle relaxant, and an anti-diarrhea agent.

[0164] The following examples are provided to more precisely define and enable the compositions and methods of the present invention. It is understood that there are numerous other embodiments and methods of using the present invention that will be apparent embodiments to those of ordinary skill in the art after having read and understood this specification and examples. The following examples are meant to illustrate one or more embodiments of the invention and are not meant to limit the invention to that which is described below.

#### Examples

##### Example 1

#### Sodium Deoxycholate and Phosphatidylcholine Formulations

[0165] Phosphatidylcholine bile salt formulation (PBF) (5.0% highly purified soy derived PC, 4.75% sodium deoxycholate, and 0.9% benzyl alcohol, in sterile water, Table 2) was obtained from Hopewell Pharmacy, Hopewell, N.J. Sodium deoxycholate and Triton® X-100 detergent (Triton®, alkylaryl polyether alcohol) were obtained from

Sigma-Aldrich Corp. (St. Louis, Mo.). Empigen® BB detergent (Empigen®, lauryldimethylbetaine, Calbiochem, Biosciences, Inc., La Jolla, Calif.). Stock reagents (5% dilutions) were prepared in PBS buffer.

[0166] The molecular structure of (a) phosphatidylcholine, (b) sodium deoxycholate and (c) benzyl alcohol are depicted in FIG. 1.

TABLE 2

Injectable PBF	
Phosphatidylcholine	5.00% (w/v)
Sodium deoxycholate	4.75%
Benzyl alcohol	0.90%
Water	100 mL

#### Example 2

#### Effects of Sodium Deoxycholate and Phosphatidylcholine Solutions in Cultured Cells

[0167] To measure cell viability after detergent treatment, HaCaT human keratinocyte cells were cultured in DMEM (Dulbecco's modified Eagle's medium) supplemented with 10% fetal calf serum, penicillin, and streptomycin. HaCaT cells were cultured in 6 well plates and incubated with 0%, 0.005%, 0.050% or 0.500% PBF (PC Formula) or sodium deoxycholate for 30 min at 37° C. prior to determination of cell viability using the MTS assay, which uses a tetrazolium compound that produces a color change when bioreduced by metabolically active cells (CellTiter 96® AQ<sub>ueous</sub> Non-Radioactive Cell Proliferation Assay, Promega, Corp. Madison, Wis.). Cell viability was determined by an absorbance spectrophotometer (at 490 nm) after a 4 hour incubation with the assay at 37° C. To determine cell viability in fresh tissue, fat specimens were incubated for 4 hours in 24 well plates with stock reagents and the MTS assay. Tissue specimens were then visualized for color change and the amount of MTS in their supernatants was measured by absorbance (at 490 nm). All studies were performed in triplicate. Absorbance at 490 nm (OD 490) is proportional to the number of living cells in the culture. There was comparable OD 490 in the control and 0.005% dilutions of both compounds (FIG. 2a), indicating little effect of these substances on cell viability at this concentration. Cell viability progressively decreased at 0.05% and 0.5% concentrations of both solutions.

[0168] Cell lysis in response to detergent treatment was determined in HaCaT cells incubated with the reagents at the indicated cell dilutions for 30 min at 37° C. Lactate dehydrogenase release was measured by absorbance (at 490 nm) after a 1 hour incubation with the LDH assay as recommended by the manufacturer (CytoTox 96® Non-Radioactive Cytotoxicity Assay, Promega). All studies were performed in triplicate. LDH release is directly proportional to absorbance at 490 nm (OD 490). There was minimal LDH release from control cells and those incubated with 0.005% dilutions of both compounds (FIG. 2b). There was progressively more LDH released at 0.05% and 0.5% of the PBF and deoxycholate.

#### Example 3

#### Effects of Sodium Deoxycholate and Phosphatidylcholine Solutions in Porcine Tissue

[0169] Porcine tissue was obtained immediately after sacrifice, shaved, and placed on ice for a maximum of four hours

before use. Fat specimens were obtained by removing the epidermis and dermis of a punch biopsy with a scalpel and trimmed. Fat specimens were loaded with calcein dye by incubating 1 hour at 37° C. with Calcein-AM (Sigma). Stock reagents were added to the fat specimens and incubated for 30 min at 37° C. with gentle agitation. Calcein retention was determined by tissue fluorescence using purple (411 nm) light and visually observing the emitted green (500 nm) light using an emission filters.

**[0170]** Histology was performed by injecting stock reagent solutions (0.5 mL) into full thickness porcine skin at various levels (epidermis, dermis, and subcutaneous tissue) with 1.0 mL syringes and 30-gauge, 0.5 inch needles. Needle depth was visualized along the margin of the porcine tissue with the intent of saturating the target tissue. One hour after incubation with PBS at 37° C., multiple 5.0 mm biopsy specimens were obtained from the injected sites, each condition performed in triplicate. Tissue was fixed in formaldehyde, paraffin-embedded, and stained with hematoxylin-eosin. Specimens were evaluated by a board-certified dermatopathologist who was blinded to the treatment protocol.

**[0171]** Fresh porcine skin was used to determine if the effects of these detergent substances on cultured cells were similar in tissue. FIG. 3a demonstrates the production of dark purple pigment (indicating viable cells) in fat tissue treated with the PBS buffer (negative control) using the MTS assay. The PBF and 5% solutions of deoxycholate and Triton® detergent (positive control) demonstrated a comparable loss of purple dye (indicating cell death) in the treated fat specimens. The difference in fat cell viability between the solutions was quantified by measuring the absorbance (at 490) of the supernatants collected from the treated fat specimens (FIG. 3b). All reagents had significant effects on the fat cell viability of fresh tissue.

**[0172]** Cell lysis was confirmed using a calcein dye release assay. Calcein becomes fluorescent after hydrolysis and is retained in cells that have intact cell membranes. Because it does not label dead cells and is lost under conditions that cause cell lysis, loss of green fluorescence in fat tissue samples loaded with the dye calcein indicates cell lysis (FIG. 4). Samples treated with the deoxycholate, PBF, and Triton® detergent (positive control) exhibited similar loss of fluorescence.

**[0173]** The histologic changes resulting from injection of PBF, deoxycholate, and Empigen®, are shown in FIG. 5. Phosphatidylcholine bile salt formulation (FIG. 5b) and deoxycholate (FIG. 5d) produced histologic effects similar to those caused by Empigen® (FIG. 5g) and Triton® (not shown), two well-characterized laboratory detergents. These changes were apparent in both fat and muscle. Marked blurring and dissolution of adipocyte cell membranes with disruption of its normal lobular architecture were seen, after injection of both the PBF (FIG. 5b) and deoxycholate (FIG. 5d). FIG. 5f demonstrates muscle fiber disarray and atrophy after PBF injection. Similar changes in muscle tissue were visible in the specimens treated with deoxycholate and the Triton® and Empigen® detergents. There were no changes in the epidermis, dermis, or adnexal structures after injection of the reagents with the exception of Empigen®, which caused loss of fibroblast nuclear staining and hyalinization of dermal collagen.

#### Example 4

##### Clinical Experience with Sodium Deoxycholate Compositions

**[0174]** Patients having lipomas, benign, isolated collections of adipose tissue, were injected with sodium deoxycho-

late (DC) solutions without phosphatidylcholine directly into the lipoma. The results of this study demonstrate that the detergent effects of deoxycholate seen on fat in animal tissues are reproducible clinically in humans. All injected lipomas were reduced in size after at least one treatment with varied concentrations of deoxycholate (Table 3). A lipoma from one patient, injected with 1% DC, was excised after treatment and pathological and histological analysis performed. Within the excised lipoma, necrosis is visible grossly (FIG. 6a) with a well demarcated area of hemorrhage and necrosis on the lateral edge extending into the middle of the lipoma fat which contrasts with the normal lipoma fat which is lighter in color. Histological analysis (FIG. 6b) reveals a well defined area of hemorrhage and necrotic fat as well as a significant inflammatory reaction which contrasts to the adjacent normal round clear fat cells.

TABLE 3

Reduction in size of lipomas after DC treatment			
Lipoma	Size (cm) Pre-treatment	Size (cm) Post-treatment	Total Treatments (% DC injected)
1	2.00 × 1.00	1.25 × 0.50	2 (2.5%)
2	2.00	1.50 × 0.50	3 (5% and 2.5%)
3	2.00 × 2.50	2.00 × 1.00	3 (5% and 2.5%)
4	4.00 × 1.75	2.50 × 2.00	2 (1%)
5	2.00 × 1.75	1.25	2 (1%)
6	2.80	0.50	1 (5%)
7	1.00	Imperceptible	1 (1%)

**[0175]** Unless otherwise indicated, all numbers expressing quantities of ingredients, properties such as molecular weight, reaction conditions, and so forth used in the specification and claims are to be understood as being modified in all instances by the term “about.” Accordingly, unless indicated to the contrary, the numerical parameters set forth in the following specification and attached claims are approximations that may vary depending upon the desired properties sought to be obtained by the present invention. At the very least, and not as an attempt to limit the application of the doctrine of equivalents to the scope of the claims, each numerical parameter should at least be construed in light of the number of reported significant digits and by applying ordinary rounding techniques. Notwithstanding that the numerical ranges and parameters setting forth the broad scope of the invention are approximations, the numerical values Size (cm) set forth in the specific examples are reported as precisely as possible. Any numerical value, however, inherently contains certain errors necessarily resulting from the standard deviation found in their respective testing measurements.

**[0176]** The terms “a” and “an” and “the” and similar referents used in the context of describing the invention (especially in the context of the following claims) are to be construed to cover both the singular and the plural, unless otherwise indicated herein or clearly contradicted by context. Recitation of ranges of values herein is merely intended to serve as a shorthand method of referring individually to each separate value falling within the range. Unless otherwise indicated

herein, each individual value is incorporated into the specification as if it were individually recited herein. All methods described herein can be performed in any suitable order unless otherwise indicated herein or otherwise clearly contradicted by context. The use of any and all examples, or exemplary language (e.g. "such as") provided herein is intended merely to better illuminate the invention and does not pose a limitation on the scope of the invention otherwise claimed. No language in the specification should be construed as indicating any non-claimed element essential to the practice of the invention.

[0177] Groupings of alternative elements or embodiments of the invention disclosed herein are not to be construed as limitations. Each group member may be referred to and claimed individually or in any combination with other members of the group or other elements found herein. It is anticipated that one or more members of a group may be included in, or deleted from, a group for reasons of convenience and/or patentability. When any such inclusion or deletion occurs, the specification is herein deemed to contain the group as modified thus fulfilling the written description of all Markush groups used in the appended claims.

[0178] Preferred embodiments of this invention are described herein, including the best mode known to the inventors for carrying out the invention. Of course, variations on those preferred embodiments will become apparent to those of ordinary skill in the art upon reading the foregoing description. The inventor expects skilled artisans to employ such variations as appropriate, and the inventors intend for the invention to be practiced otherwise than specifically described herein. Accordingly, this invention includes all modifications and equivalents of the subject matter recited in the claims appended hereto as permitted by applicable law. Moreover, any combination of the above-described elements in all possible variations thereof is encompassed by the invention unless otherwise indicated herein or otherwise clearly contradicted by context.

[0179] Furthermore, numerous references have been made to patents and printed publications throughout this specification. Each of the above cited references and printed publications are herein individually incorporated by reference in their entirety.

[0180] In closing, it is to be understood that the embodiments of the invention disclosed herein are illustrative of the principles of the present invention. Other modifications that may be employed are within the scope of the invention. Thus, by way of example, but not of limitation, alternative configurations of the present invention may be utilized in accordance with the teachings herein. Accordingly, the present invention is not limited to that precisely as shown and described.

#### REFERENCES

- [0181] 1. Rifles P G. The use of phosphatidylcholine for correction of lower lid bulging due to prominent fat pads. *Dermatol Surg* 2001, 27:391-2.
- [0182] 2. Ablon G, Rotunda A M. Treatment of lower eyelid fat pads using phosphatidylcholine: clinical trial and review. *Derm Surgery* 2004, 30:422-7.
- [0183] 3. Serra M. Subcutaneous infiltration with phosphatidylcholine solution for treatment of buffalo hump and fatty pads. *Antiviral Therapy* 2001, 6:75-6.
- [0184] 4. ASAPS. American Society for Aesthetic Plastic Surgery. Lipoplasty (liposuction) without surgery?, October, 2002.
- [0185] 5. Bauman L S. Phosphatidylcholine. *Skin and Allergy News* 2003, 34.
- [0186] 6. Bates B. 'Fat dissolving' substance injects CCs of controversy. *Skin and Allergy News* 2003, 34.
- [0187] 7. Bellman B. Phosphatidylcholine reaction. *Skin and Allergy News* 2003, 34.
- [0188] 8. Victor S. Phosphatidylcholine works. *Skin and Allergy News* 2003, 34.
- [0189] 9. Lichtenberg D, Zilberman Y, Greenzaid P, Zamir S. Structural and kinetic studies on the solubilization of lecithin by sodium deoxycholate. *Biochemistry* 1979, 18:3517-25.
- [0190] 10. Lichtenberg D, Robson R J, Dennis E A. Solubilization of phospholipids by detergents. Structural and kinetic aspects. *Biochim Biophys Acta* 1983, 737:285-304.
- [0191] 11. Teelmann K, Schlappi B, Schupbach M, Kistler A. Preclinical safety evaluation of intravenously administered mixed micelles. *Arzneimittelforschung* 1984, 34:1517-23.
- [0192] 12. Durr M, Hager J, Lohr J P. Investigation on mixed micelle and liposome preparations for parenteral use on soya phosphatidylcholine. *Eur J Pharm Biopharm* 1994, 40:147-56.
- [0193] 13. Alkan-Onyuksel H, Ramakrishnan S, Chai H B, Pezzuto J M. A mixed micellar formulation suitable for the parenteral administration of taxol. *Pharm Res* 1994, 11:206-12.
- [0194] 14. Hammad M A, Muller B W. Increasing drug solubility by means of bile salt-phosphatidylcholine-based mixed micelles. *Eur J Pharm Biopharm* 1998, 46:361-7.
- [0195] 15. Pamham M J, Wendel A. Phospholipids and liposomes—safety for cosmetic and pharmaceutical use. Nattermann Phospholipid GMBH Scientific Publication No. 2 1995.
- [0196] 16. Lipostabil. Product insert: Aventis Pharma, 2003.
- [0197] 17. Goldman L, Bennet J C, Cecil R L. Cecil Textbook of Medicine. St. Louis, Mo.: W.B. Saunders Co., 2001.
- [0198] 18. Womack M D, Kendall D A, MacDonald R C. Detergent effects on enzyme activity and solubilization of lipid bilayer membranes. *Biochim Biophys Acta* 1983, 733:210-5.
- [0199] 19. Lichtenberg D. Characterization of the solubilization of lipid bilayers by surfactants. *Biochim Biophys Acta* 1985, 821:470-8.
- [0200] 20. Banerjee P, Joo J B, Buse J T, Dawson G. Differential solubilization of lipids along with membrane proteins by different classes of detergents. *Chem Phys Lipids* 1995, 77:65-78.
- [0201] 21. Almgren M. Mixed micelles and other structures in the solubilization of bilayer lipid membranes by surfactants. *Biochim Biophys Acta* 2000, 1508:146-63.
- [0202] 22. Schuck S, Honsho M, Ekroos K, Shevchenko A, Simons K. Resistance of cell membranes to different detergents. *Proc Natl Acad Sci* 2003, 100:5795-800.
- [0203] 23. Heerklotz H, Seelig J. Correlation of membrane/water partition coefficients of detergents with the critical micelle concentration. *Biophys J* 2000, 78:2435-40.
- [0204] 24. Learn about lecithins. Oxford, Conn.: American Lecithin Company, 2003.
- [0205] 25. Canty D, Zeisel S, Jolitz A. Lecithin and choline: research update on health and nutrition. Fort Wayne, Ind.: Central Soya Company, Inc., 1996.



- [0206] 26. Feldman M, Scharschmidt B F, Sleisenger M H, Fordtran J S, Zorab R. Sleisenger & Fordtran's Gastrointestinal and Liver Disease. New York: Saunders, 2002.
- [0207] 27. Lipostabil. Rhone-Polenc Rorer. Cologne, West Germany: Natterman International GMBH, 1990.
- [0208] 28. Jones M N. Surfactants in membrane solubilisation. *Int J Pharm* 1999, 177:137-59.
- [0209] 29. Gustafson C, Tagesson C. Influence of organic solvent mixtures on biological membranes. *Br J Ind Med* 1985, 42:591-5.
- [0210] 30. Lester D S, Baumann D. Action of organic solvents on protein kinase C. *Eur J Pharmacol* 1991, 206:301-8.
- [0211] 31. Engelke M, Jessel R, Wiechmann A, Diehl H A. Effect of inhalation anaesthetics on the phase behaviour, permeability and order of phosphatidylcholine bilayers. *Biophys Chem* 1997, 67:127-38.
- [0212] 32. Ebihara L, Hall J E, MacDonald R C, McIntosh T J, Simon S A. Effect of benzyl alcohol on lipid bilayers. A comparisons of bilayer systems. *Biophys J* 1979, 28:185-96.
- [0213] 33. Gordon L M, Sauerheber R D, Esgate J A, Dipple I, Marchmont R J, Houslay M D. The increase in bilayer fluidity of rat liver plasma membranes achieved by the local anesthetic benzyl alcohol affects the activity of intrinsic membrane enzymes. *J Biol Chem* 1980, 255:4519-27.
- [0214] 34. Singer S J, Nicolson G L. The fluid mosaic model of the structure of cell membranes. *Science* 1972, 175:720-31.
- [0215] 35. Rittes P G. The use of phosphatidylcholine for correction of localized fat deposits. *Aesthetic Plast Surg* 2003, 27:315-8.

1-53. (canceled)

54. A non-surgical method for improving the appearance of a human having a localized fat accumulation and desiring the removal thereof, said method comprises local administration to said fat accumulation a composition consisting essentially of a detergent and phosphatidylcholine, which detergent is deoxycholic acid, or a salt thereof, wherein said detergent reduces the localized fat accumulation thereby improving the appearance of said human, and wherein said detergent is contained in excess of phosphatidylcholine by mass.

55. A non-surgical method for improving the appearance of a human having a localized fat accumulation and desiring the removal thereof, said method comprises local administration to said fat accumulation a composition comprising a detergent and phosphatidylcholine, which detergent is deoxycholic acid, or a salt thereof, wherein said detergent reduces the localized fat accumulation thereby improving the appearance of said human, and wherein said detergent is contained in excess of phosphatidylcholine by mass.

56. The method of claim 54 or 55, wherein said fat accumulation is localized in an area selected from the group consisting of: a thigh, the abdomen, the buttock, calf, an ankle, the upper back, the chin, an arm, the waist, and the hip.

57. A method for treating a patient having lipomas comprising local administration to said lipomas of said patient a composition consisting essentially of a detergent and phosphatidylcholine, which detergent is deoxycholic acid, or a salt thereof, wherein said detergent reduces the size of said lipomas thereby treating said patient, and wherein said detergent is contained in excess of phosphatidylcholine by mass.

58. A method for treating a patient having lipomas comprising local administration to said lipomas of said patient a composition comprising a detergent and phosphatidylcholine, which detergent is deoxycholic acid, or a salt thereof, wherein said detergent reduces the size of said lipomas thereby treating said patient, and wherein said detergent is contained in excess of phosphatidylcholine by mass.

59. The method of any one of claims 54, 57, and 58, wherein the concentration of the detergent is up to 5% (w/v) deoxycholic acid or the salt thereof.

60. The method of any one of claims 54, 57, and 58, wherein the concentration of the detergent is about 0.1%, 0.5%, or 1% (w/v) deoxycholic acid or the salt thereof.

61. The method of any one of claims 54, 57, and 58, wherein said salt is sodium salt.

62. The method of any one of claims 54, 57, and 58, wherein said local administration comprises subcutaneous injection.

63. The method of any one of claims 54, 57, and 58, wherein said composition further comprises a penetration enhancer.

64. The method of any one of claims 54, 57, and 58, wherein said composition further comprises hyaluronidase and/or collagenase.

65. The method of any one of claims 54, 57, and 58, wherein said composition further comprises an active ingredient which is not phosphatidylcholine.

66. The method of claim 65, wherein said active ingredient is an anti-inflammatory agent and/or an analgesic.

67. The method of claim 65, wherein said active agent is an analgesic.

68. The method of claim 67, wherein said analgesic is lidocaine.

69. The method of any one of claims 54, 57, and 58, wherein the ratio of the detergent to phosphatidylcholine is 1:0.5.

70. The method of any one of claims 54, 57, and 58, wherein the ratio of the detergent to phosphatidylcholine is 1:0.05.

71. The method of any one of claims 54, 57, and 58, wherein the ratio of the detergent to phosphatidylcholine is 1:0.05.

72. A method for non-surgical removal of a localized fat deposit in a patient having such deposit and desiring to remove such deposit, which method comprises contacting the fat deposit with a composition comprising an effective amount of deoxycholic acid or a salt thereof, phosphatidylcholine and a pharmaceutically acceptable excipient, and wherein said deoxycholic acid or the salt thereof is contained in excess of phosphatidylcholine by mass.

73. A method for non-surgical removal of a localized fat deposit in a patient having such deposit and desiring to remove such deposit, which method comprises contacting the fat deposit with a composition consisting essentially of an effective amount of deoxycholic acid or a salt thereof, phosphatidylcholine and a pharmaceutically acceptable excipient, and wherein said deoxycholic acid or the salt thereof is contained in excess of phosphatidylcholine by mass.

74. A cosmetic method for non-surgical removal of a localized fat deposit in a patient having such deposit and desiring to remove such deposit, which method comprises contacting the fat deposit with a composition comprising an effective amount of deoxycholic acid or a salt thereof, phosphatidylcholine and a pharmaceutically acceptable excipient, and

wherein said deoxycholic acid or the salt thereof is contained in excess of phosphatidylcholine by mass.

**75.** A cosmetic method for non-surgical removal of a localized fat deposit in a patient having such deposit and desiring to remove such deposit, which method comprises contacting the fat deposit with a composition consisting essentially of an effective amount of deoxycholic acid or a salt thereof, phosphatidylcholine and a pharmaceutically acceptable excipient, and wherein said deoxycholic acid or the salt thereof is contained in excess of phosphatidylcholine by mass.

**76.** A syringe for subcutaneous injection wherein said syringe comprises a sterile aqueous composition comprising a fat removing effective amount of up to 5% (w/v) of a detergent which is deoxycholic acid or a salt thereof, and phosphatidylcholine, wherein the detergent is contained in excess of phosphatidylcholine by mass.

**77.** The syringe of claim **76**, further containing at least another active ingredient.

**78.** The syringe of claim **76**, wherein the fat removing effective amount is from 0.05% to 5% (w/v).

**79.** The syringe of claim **76**, wherein the detergent is the salt of deoxycholic acid.

**80.** The syringe of claim **76**, wherein the salt is sodium deoxycholate.

**81.** A composition comprising an adipose cell and aqueous solution of a fat removing bile acid or a salt thereof at a concentration of no more than 5% (w/v) and phosphatidylcholine, wherein the bile acid or the salt thereof is contained in excess of phosphatidylcholine by mass.

**82.** The composition of claim **81**, wherein the concentration of the bile acid or the salt is from 0.05% to 5% (w/v).

**83.** The composition of claim **82**, wherein the bile acid is deoxycholic acid.

**84.** The composition of claim **82**, wherein the bile acid salt is sodium deoxycholate.

\* \* \* \* \*