

June 13, 1961

R. MENGHI  
DEVICE FOR SECURING SKIS AND BAGGAGE ON  
THE ROOF OF MOTOR CARS  
Filed June 2, 1959

2,988,253

*Fig. 1*

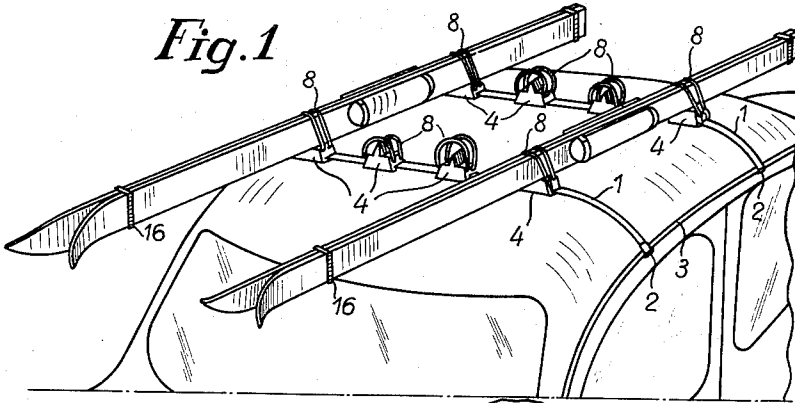

*Fig. 2*

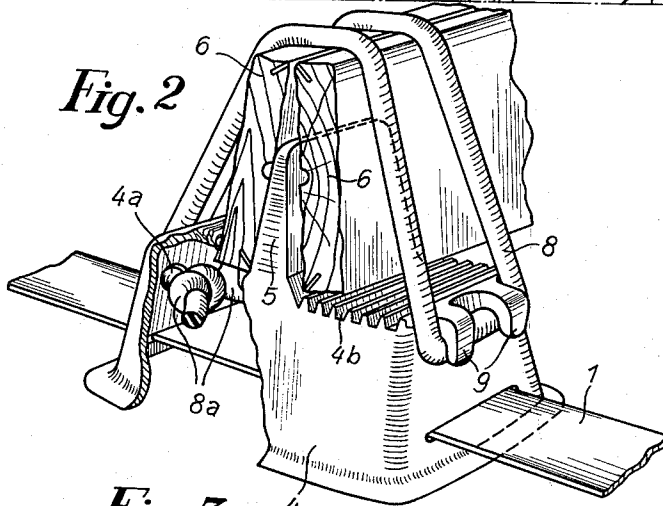

*Fig. 3*

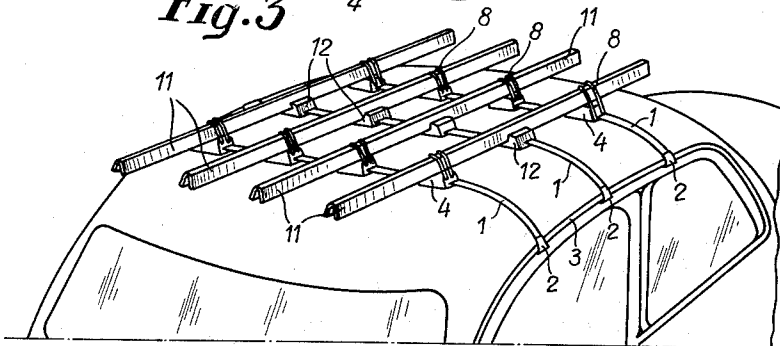

1

2,988,253

**DEVICE FOR SECURING SKIS AND BAGGAGE ON THE ROOF OF MOTOR CARS**

Roberto Menghi, 7 Via Marchiondi, Milan, Italy

Filed June 2, 1959, Ser. No. 817,642

Claims priority, application Italy June 6, 1958

2 Claims. (Cl. 224-42.1)

This invention relates to a device adapted to be fitted to the roof of motor cars for attaching skis and baggage, of the type comprising straps of flexible material provided at their ends with hook members for fastening them, transversely of the roof, under the roof gutters, and lugs adapted to bear on the roof, the lugs being connected to the straps, either the straps or lugs being provided with means for fastening the skis to the lugs.

In devices of this type known heretofore, the skis are mostly laid flat with their tip to the back, in order to avoid the wind thrust during drive of the car from lifting them from the car roof when driving at high speed. Such lifting would cause abnormal stresses on the straps which may lead in some cases to breakage of the straps, loss of the skis and easily imaginable damages to the vehicles which follow.

Moreover, in known devices of this type the fastening means comprises resilient cords in loop form permanently attached to the ends of the strap or lug, adapted to be fastened by their loops over hooks secured to the strap or lug. Owing to the very reduced space, fastening of the loop over the hook is often relatively difficult to carry out and has to be performed with bare hands which, when temperature is very low, may be a serious drawback.

This invention provides a device of the type referred to above, which safely prevents loosening of the skis from the roof or breakage of the straps by the wind thrust, fastening of the skis to the device being greatly facilitated and easily carried out with gloved hands.

A further object of this invention is to provide a device of the type referred to above, which can easily be converted to a baggage holder by the addition of very simple component parts.

The improved device is characterized by the fact that each lug is centrally formed with a ridge or web extending transversely of the strap, on either side of which a ski is placed edge up.

Further characteristic features of this invention will be understood from the appended detailed description referring to the accompanying drawings, wherein:

FIGURE 1 is a perspective view of a motor car roof equipped with the improved ski holding device.

FIGURE 2 is a partly cut away perspective view of one of the ski supporting lugs and,

FIGURE 3 is a perspective view of a motor car equipped with the improved device for holding baggage.

The device comprises straps 1 of flexible material, such as rubberised cloth having at their ends hook members 2 for fastening them transversely of the roof under the roof gutter 3.

Lugs generally denoted by 4 are threaded on the straps, the lugs having means for fastening the skis thereto.

According to this invention each lug, which will be more clearly visible in FIGURE 2 in a part sectional perspective view, is formed with a ridge or web 5 extending transversely of the strap 1, on either side of which a ski 6 is arranged substantially edge up. As clearly shown in FIGURE 1, the skis are moreover conveniently arranged with diverging tips, so that the wind thrust acting on the tip of each ski in each pair which may result in separating the skis from one another is absorbed by the belt 16 holding together the skis in proximity to

2

their tips, and is not transmitted to the pad 4. If desired, the skis may preferably be arranged with their tips turned to the back of the motor car.

According to a further aspect of this invention, the lug 4 is made hollow and opens downwardly in an inverted cup shape the means for fastening the two skis to the lug comprising a resilient cord 8, such as a rubber cord sheathed by a cotton braiding, the ends of which extend through holes 4a bored in one side wall of the lug and are knotted at 8a within the lug cavity, the resulting loop being drawn over both skis and engaged under two hooks 9 provided on the opposite side-wall of the lug at a location adjacent the top edge of the latter. The hooks are two in number, in order to facilitate unfastening of the cord by slipping a finger, which may be gloved, between the hooks.

Conveniently, the longitudinal ridge or web has a cross sectional shape of an isosceles triangle, that is a wedge form, the height of which is substantially greater than the base; moreover, the top surface of the lug is formed with grooves 4b parallel with the ridge 5, in which the ski edges are engaged. Finally, the lower edge of the hollow lug is outwardly curved and thins out to a lip form to avoid damaging the roof paint even when the lug is made of plastics, such as polyvinyl chloride.

The improved device may easily be adapted to hold baggage by means of rods or structural members 11 of inverted V-shape (FIGURE 3), which are fitted on the ridge or web of two longitudinally aligned lugs on the motor car roof. The rods are secured by means of the resilient cords 8 provided for holding the skis when the device is used as a ski holder.

If desired, additional lugs 12 may be interposed between the forward and rearward lugs, the said additional lugs being formed with a longitudinal groove, or a rib or web similar to the rib 5 on the lugs 4, which is inserted into the channel of the U-shaped structural member. The lugs 12 may be secured to a strap 1 similar to the above described straps.

It will be seen that the lugs are of substantial height, so that fastening of the resilient cords 8 for holding the skis, or rods 11 when the device is used as a baggage holder, is very easy and can be carried out with gloved hands.

It will be understood that, the principle of the invention being left unaltered, embodiments and constructional details may be widely varied with respect to the non-limiting example described and shown, without departing from the scope of this invention.

What I claim is:

1. In a ski-securing device for motor vehicle roofs of the character comprising a strap of flexible material having at each opposite end a hook member for engaging the roof gutters of the vehicle to fasten said strap to the vehicle roof transversely of the latter, and at least one ski supporting lug carried by said strap to rest on said roof, an erected web section extending transversely of the length of the strap on the top surface of each lug, said lugs being of an inverted cup-shape having its free edges outwardly curved and adapted to bear on said roof, said web on each lug being of a wedge-shaped cross-sectional profile, the highest of which is substantially greater than its base, the zones on the top face of the lugs adjacent the opposite sides of said webs each forming a supporting surface for one ski and being provided with a plurality of grooves extending substantially parallel with the web, ski bracing means on each lug comprising a loop of a resilient cord having its ends extending through a pair of holes provided in a lateral wall of the lug into the inner cavity of the latter, and having a knot thereon for anchoring said loop to said lateral wall of the lug, and a pair of spaced hooks protruding from the

3

other lateral wall of the lug and spaced therebetween in a direction parallel with the web of said lug, whereby said loop may be anchored to said other lateral wall of the lug by extending over said web and the skis adjacent to the latter for fastening the skis to the vehicle roof.

2. A device for securing skis to motor vehicle roofs comprising at least a pair of straps of flexible material, hook members at opposite ends of each strap for engaging the roof gutters of the vehicle to thereby permit arranging said straps on the top of the vehicle roof transversely of the latter, at least one lug for each strap having means for securing it to one strap and adapted to bear on the vehicle roof held against the latter by said strap, said lug being of inverted cup-shape and rectangular in cross section and having their free-edges outwardly curved and bearing on the roof; said means for securing the lugs to the straps comprising through slots provided in opposite side walls of said lugs at a region spaced from the free edges of said walls, said straps each extending through the slots of the lugs secured thereto, an erected flat ridge on the outer surface of the bottom portion of each cup-shaped lug, said ridge extending parallel with the side walls of the lug in which said slots for the passage of the strap are provided and

4

lying in the middle longitudinal plane of the lug and being of wedge-shape in cross-section, said ridge defining at each side thereof ski supporting planes on the outer surface of the bottom portion of the cup-shaped lug, a ski bracing member on each lug comprising a loop of resilient cord having its opposite ends extending through a pair of holes provided in a lateral wall having the slot for the passage of said strap cut therein and arranged intermediate said slot and the bottom portion of the cup-shaped lug inside of said cup shaped lug and having knots formed thereon for anchoring said loop to said lug, a fork shaped hook protruding from the other lateral wall of the lug opposite that to which said loop is anchored for engaging said loop, thereby allowing the fastening of a pair of skis bearing by their one edge on the ski supporting planes adjacent said rib to said lug by passing the loop above the other ski edges.

#### References Cited in the file of this patent

##### FOREIGN PATENTS

68,955	France	Mar. 17, 1958
62,835	Denmark	Oct. 9, 1944
177,071	Austria	Dec. 28, 1953