

No. 607,880.

Patented July 26, 1898.

L. RAINS.  
HOE.

(Application filed May 22, 1897.)

(No Model.)

3 Sheets—Sheet 1.

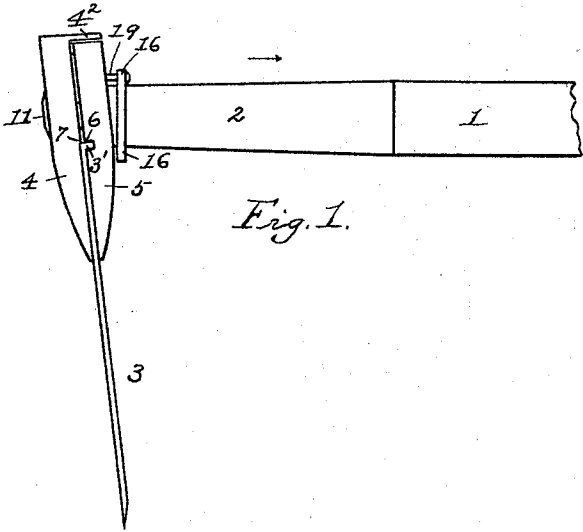

Fig. 1.

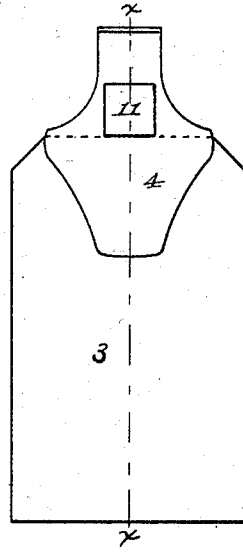

Fig. 2.

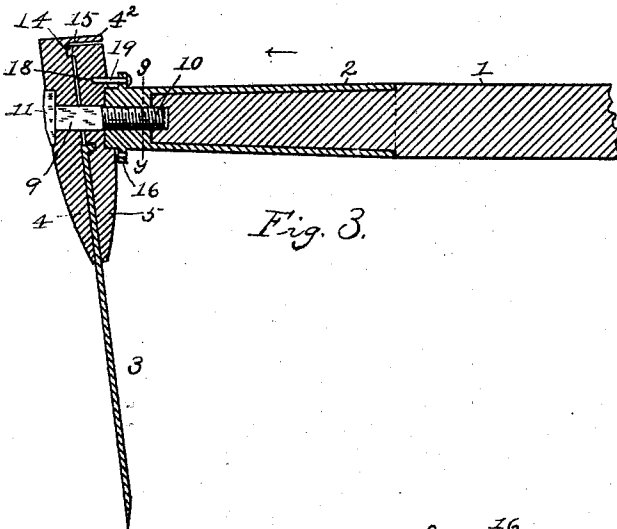

Fig. 3.

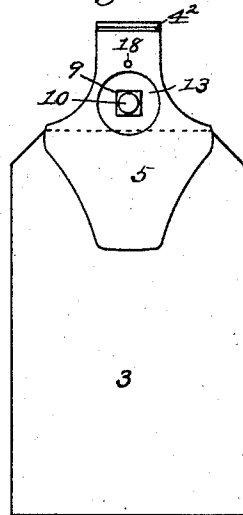

Fig. 4.

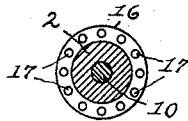

Fig. 5.

WITNESSES:

W. H. Logan.  
A. M. Mackerley

INVENTOR:

Lafayette Rains.  
BY  
Eugene L. Arnett,  
ATTORNEY.

L. RAINS.  
HOE.

(Application filed May 22, 1897.)

(No Model.)

3 Sheets—Sheet 2.

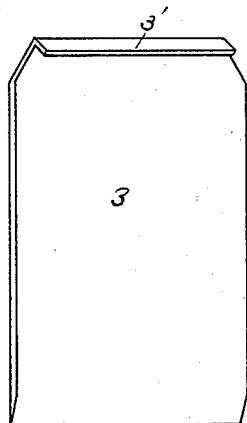

Fig. 6.

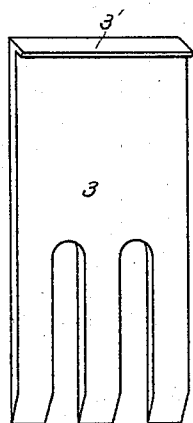

Fig. 7.

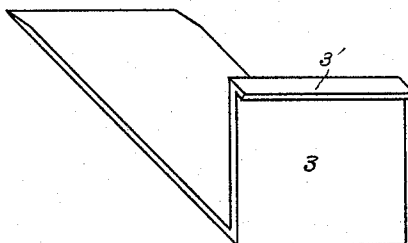

Fig. 8.

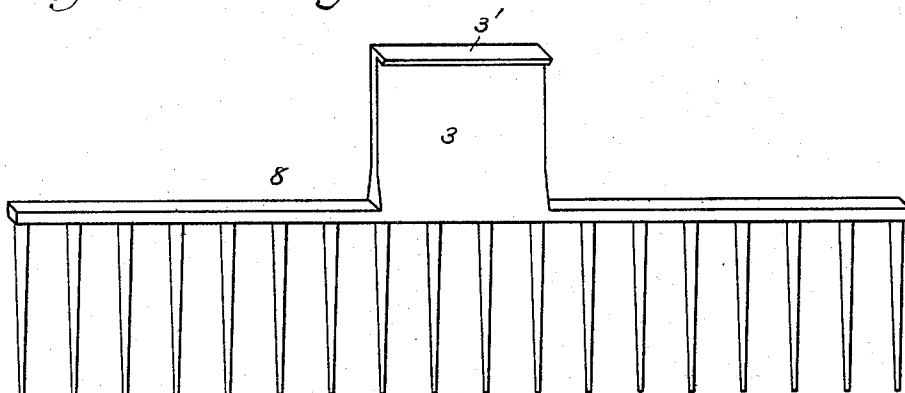

Fig. 9.

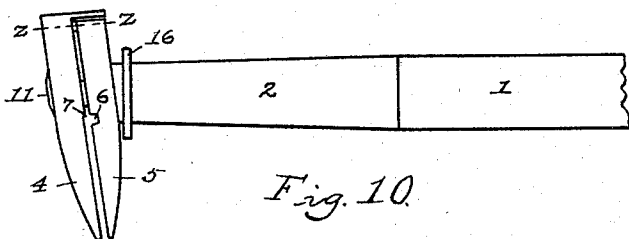

Fig. 10.

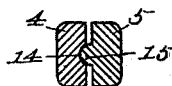

Fig. 11.

WITNESSES:

W. H. Logan  
A. M. Muckerley

INVENTOR:

Lafayette Rains,  
BY  
Eugene L. Arnott,  
ATTORNEY.

No. 607,880.

Patented July 26, 1898.

L. RAINS.  
HOE.

(Application filed May 22, 1897.)

(No. Model.)

3 Sheets—Sheet 3.

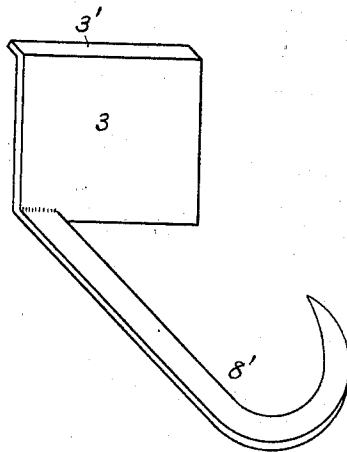

Fig. 12.

WITNESSES:

*Wm. H. Logan*  
*A. M. Mackelup*

INVENTOR:

*Lafayette Rains,*  
BY  
*Engel L. Arnott,*  
ATTORNEY.

# UNITED STATES PATENT OFFICE.

LAFAYETTE RAINS, OF GREENFIELD, OHIO.

HOE.

SPECIFICATION forming part of Letters Patent No. 607,880, dated July 26, 1898.

Application filed May 22, 1897. Serial No. 637,664. (No model.)

*To all whom it may concern:*

Be it known that I, LAFAYETTE RAINS, a citizen of the United States, residing at Greenfield, in the county of Highland and State of Ohio, have invented certain new and useful Improvements in Hoes, of which the following is a specification, reference being had to the accompanying drawings.

This invention relates to hoes and similar implements; and the object of the invention is to provide a hoe or similar implement with clamping-jaws in which the blade is held, so that the blade may be quickly and easily inserted or removed. With this device blades adapted to different kinds of work may be used successively with the same handle and clamping-jaws.

In the accompanying drawings, Figure 1 is a side elevation of a hoe provided with my improvements. Fig. 2 is an end view looking in the direction of the arrow in Fig. 1. Fig. 3 is a central vertical section on line  $x x$  of Fig. 2. Fig. 4 is a view looking in the direction of the arrow in Fig. 3, the handle and ferrule being removed. Fig. 5 is a detail view taken in cross-section on line  $y y$  of Fig. 3. Figs. 6, 7, and 8 represent different forms of blades. Fig. 9 represents a rake adapted to be held in the clamping-jaws. Fig. 10 is a side elevation of a hoe with the blade removed from the clamping-jaws. Fig. 11 is a detail view taken in cross-section on line  $z z$  of Fig. 10.

In the drawings the numeral 1 represents the handle, part of which is broken away. The end of the handle is inserted in a ferrule 2. The blade 3 has a portion 3' at its upper edge formed or bent over at right angles to the blade. The blade is held between the clamping-jaws 4 and 5. These jaws are set face to face, as shown, and are similar to each other in size and form. Jaw 5 is provided on its inner face with a transverse groove or recess 6, in which the portion 3' of the blade rests. Jaw 4 is provided with a slight transverse shoulder or rib 7, against which the upper edge of the blade fits. Jaws 4 and 5 are provided each with a square hole to receive the square shank 9 of bolt 10. Bolt 10 has a square head 11, which fits in a square recess in jaw 4. A circular recess 13 is provided in jaw 5 for the recep-

tion of the end of ferrule 2. The end of ferrule 2 is bored and tapped to receive the bolt 10. Jaw 4 has a notch or recess 14, and jaw 5 has a projection 15, which fits in said notch or recess. Jaw 4 has a wing or projection 4', which fits over the upper end of jaw 5. Ferrule 2 may in some cases be provided with a circular rib or flange 16, having holes 17. Jaw 5 has a hole 18 to receive pin 19, which passes through one of the holes 17.

When the blade is to be removed from the clamping-jaws, the pin 19 is first drawn out from hole 18. The handle and ferrule are then turned, so as to unscrew the ferrule slightly from bolt 10. This operation releases jaws 4 and 5 somewhat and the blade is easily slipped out sidewise.

If a new blade is to be inserted, its bent portion 3' is inserted in groove 6 and pressed in sidewise between the jaws. The ferrule 2 is then turned so as to draw the head of bolt 10 up tightly against jaw 4, thus firmly clamping the blade between the jaws. Pin 19 may then be inserted in holes 17 and 18 in some cases to prevent the ferrule from unscrewing from bolt 10, although this will rarely be found necessary.

The wing or projection 4' prevents dirt from being impacted between the heads of jaws 4 and 5 when breaking clods.

The square shank of bolt 10, the square holes in the jaws, the square head of the bolt, the square recess therefor, the transverse groove 6, the transverse shoulder 7, and the bent portion 3' of the blade engaging said groove and shoulder, the notch or recess 14, and the knob or projection 15, fitting in said notch, all tend to hold the jaws rigidly together and prevent their turning or slipping upon each other when bolt 10 is drawn up tightly.

The rake 8 is provided with a blade 3, having a bent portion 3' to enter groove 6 the same as the other blades. It is obvious that blades or tools of any convenient description may be provided with a blade 3 and a bent portion 3' to enter groove 6 and be clamped between the jaws.

Having thus fully described my invention, what I claim as new, and desire to secure by Letters Patent, is—

1. A hoe or similar implement having clamping-jaws, a transverse groove in the inner face

of one of the jaws, a blade having a bent portion to fit in said groove, and means for clamping the jaws upon the blade, substantially as set forth.

5 2. A hoe or similar implement having clamping-jaws, a transverse groove in the inner face of one of the jaws, a transverse shoulder on the inner face of the other jaw, a blade having a bent portion to fit in said groove and to  
10 engage said shoulder, and means for clamping the jaws upon the blade, substantially as set forth.

3. A hoe or similar implement having clamping-jaws, a blade clamped between said jaws,  
15 a bolt passing through said jaws and screwing into the handle, a rib or flange around said ferrule, said rib or flange having holes therein, and a pin passing through one of said holes and into a hole in one of said jaws,  
20 substantially as set forth.

4. A hoe or similar implement having clamp-

ing-jaws, a blade clamped between said jaws, said jaws having square holes, a bolt with square shank passing through said holes, said bolt having a square head which fits in a  
25 square recess in one of the jaws, one jaw having a transverse groove in its inner face, the other jaw having a transverse shoulder on its inner face, said blade having a bent portion which engages said groove and shoulder, a  
30 knob or projection on the head of one jaw engaging a notch or recess in the head of the other jaw, said bolt being screwed into the ferrule of the handle, substantially as set forth. 35

In testimony whereof I affix my signature in presence of two witnesses.

LAFAYETTE RAINS.

Witnesses:

W. H. LOGAN,  
A. M. MACKESLEY.