



- (51) **International Patent Classification:**
H04W 4/50 (2018.01) H04W 36/00 (2009.01)
- (21) **International Application Number:**
PCT/US2020/030495
- (22) **International Filing Date:**
29 April 2020 (29.04.2020)
- (25) **Filing Language:** English
- (26) **Publication Language:** English
- (30) **Priority Data:**
62/840,299 29 April 2019 (29.04.2019) US
- (71) **Applicant: APPLE INC.** [US/US]; One Apple Park Way, Cupertino, California 95014 (US).
- (72) **Inventors: SHAN, Changhong;** One Apple Park Way, Cupertino, California 95014 (US). **STOJANOVSKI, Alexandre Saso;** One Apple Park Way, Cupertino, California 95014 (US). **LIAO, Ching-Yu;** One Apple Park Way, Cupertino, California 95014 (US). **MOSES, Danny;** One Apple Park Way, Cupertino, California 95014 (US).
- (74) **Agent: KAPLUN, Oleg F. et al.;** 150 Broadway, Suite 702, New York, New York 10038 (US).

(81) **Designated States** (unless otherwise indicated, for every kind of national protection available): AE, AG, AL, AM, AO, AT, AU, AZ, BA, BB, BG, BH, BN, BR, BW, BY, BZ, CA, CH, CL, CN, CO, CR, CU, CZ, DE, DJ, DK, DM, DO, DZ, EC, EE, EG, ES, FI, GB, GD, GE, GH, GM, GT, HN, HR, HU, ID, IL, IN, IR, IS, JO, JP, KE, KG, KH, KN, KP, KR, KW, KZ, LA, LC, LK, LR, LS, LU, LY, MA, MD, ME, MG, MK, MN, MW, MX, MY, MZ, NA, NG, NI, NO, NZ, OM, PA, PE, PG, PH, PL, PT, QA, RO, RS, RU, RW, SA, SC, SD, SE, SG, SK, SL, ST, SV, SY, TH, TJ, TM, TN, TR, TT, TZ, UA, UG, US, UZ, VC, VN, WS, ZA, ZM, ZW.

(84) **Designated States** (unless otherwise indicated, for every kind of regional protection available): ARIPO (BW, GH, GM, KE, LR, LS, MW, MZ, NA, RW, SD, SL, ST, SZ, TZ, UG, ZM, ZW), Eurasian (AM, AZ, BY, KG, KZ, RU, TJ, TM), European (AL, AT, BE, BG, CH, CY, CZ, DE, DK, EE, ES, FI, FR, GB, GR, HR, HU, IE, IS, IT, LT, LU, LV, MC, MK, MT, NL, NO, PL, PT, RO, RS, SE, SI, SK, SM, TR), OAPI (BF, BJ, CF, CG, CI, CM, GA, GN, GQ, GW, KM, ML, MR, NE, SN, TD, TG).

(54) **Title:** METHODS AND APPARATUS FOR ENABLING SERVICE CONTINUITY IN AN EDGE COMPUTING ENVIRONMENT

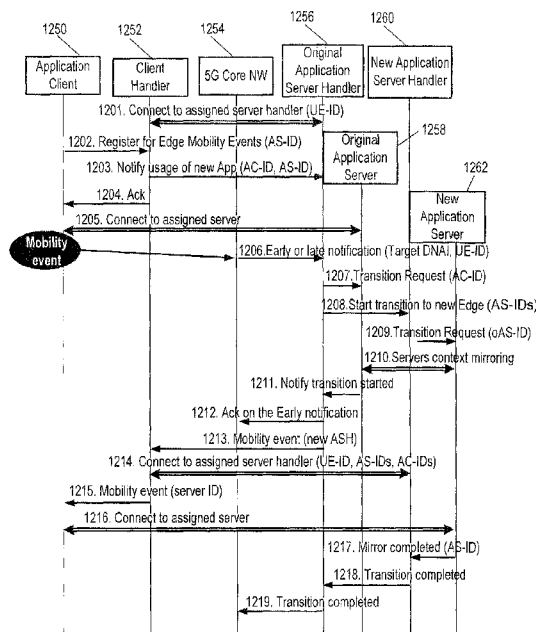

Fig. 12

(57) **Abstract:** Devices, systems and methods for transitioning a UE to a new application server in response to a mobility event comprising, at a source application server handler: receiving an application ID (AC-ID) associated with an application client for a user equipment (UE); receiving a mobility event notification including a UE ID of the UE and a target data network access identifier (DNAI) to indicate a target edge data network to which a transition of a data connection for the application client is to be performed; encoding an outgoing transition request for transmission to a source application server to indicate the transition of the data connection from the source application server; and encoding an incoming transition request for transmission to a target application server handler (ASH) of the target edge data network to indicate the transition of the data connection to the target edge data network.



Declarations under Rule 4.17:

- *as to applicant's entitlement to apply for and be granted a patent (Rule 4.17(ii))*
- *as to the applicant's entitlement to claim the priority of the earlier application (Rule 4.17(iii))*

Published:

- *with international search report (Art. 21(3))*
- *before the expiration of the time limit for amending the claims and to be republished in the event of receipt of amendments (Rule 48.2(h))*

**METHODS AND APPARATUS FOR ENABLING SERVICE CONTINUITY IN AN
EDGE COMPUTING ENVIRONMENT**

Inventors: Changhong Shan, Alexandre Saso Stojanovski, Ching-Yu Liao, and Danny Moses

5 **Priority Claim**

[0001] The present disclosure claims priority to U.S. Prov. Appln. Serial No. 62/840,299 filed April 29, 2019 and entitled “METHODS AND APPARATUS FOR ENABLING SERVICE CONTINUITY IN AN EDGE COMPUTING ENVIRONMENT,” the disclosure of which is incorporated herewith by reference.

10

Background

[0002] 3rd Generation Partnership Project (3GPP) infrastructure has various means to maintain service and session continuity for user equipment (UE) during and after a mobility event. However, these means do not cover cases in which application clients hosted on a UE connect to application servers that are deployed in Edge data networks. When application servers are deployed in Edge data networks rather than the cloud, a mobility event may influence the selection of the optimal Edge data network. That is, when the UE moves, it might be more optimal for the application client to re-connect to an application server on a different Edge data network rather than to stay connected to the old application server.

20

[0003] To access a data network (DN) via a 5G new radio (NR), the UE needs to establish a protocol data unit (PDU) Session with the network. The ordinary PDU Session can be thought of as a “layer-2” tunnel that stretches between the UE and a PDU session anchor (PSA) in the network.

25

[0004] The 5G NR defined by 3GPP also introduces the notion of PDU Session with uplink classifier (UL CL), the latter being a functionality located in an intermediate user plane function (UPF) of the PDU session that is aimed at diverting (locally) a portion of the overall traffic that matches configured traffic filters. The insertion and removal of the UL CL, as well as the UPF configuration with traffic filters, is performed by a session management function (SMF).

30

[0005] As part of Rel-16, 3GPP has specified a solution for session continuity when the UL CL functionality needs to be relocated due to UE mobility. This scenario is illustrated in Fig. 1.

5 [0006] As illustrated in Fig. 1, the UE is initially connected to the source radio access network (S-RAN) and has a PDU Session established with a remote PDU session anchor (PSA-1). The network has inserted an uplink classifier (S-ULCL) that directs selected traffic to a local PDU session anchor (PSA-2). The traffic flows exchanged via PSA-2 are terminated in a source application server (S-AS), which is a user plane entity (e.g., content distribution server) that is controlled by an application function (AF) via an interface that is outside of the scope of 3GPP.

10 [0007] At some point, the UE is handed over to the target RAN (T-RAN) upon which a target uplink classifier (T-ULCL) is instantiated and an N9 forwarding tunnel is created between the source uplink classifier (S-ULCL) and the T-ULCL.

15 [0008] According to TS 23.501 clause 5.6.4.2, the N9 forwarding tunnel is maintained until all active traffic flowing on it ceases to exist for a configurable period of time or until the AF informs the SMF that it can release the source PSA providing access to the source local DN.

20 [0009] During the existence of the N9 forwarding tunnel, the user plane function (UPF) acting as target UL CL is configured with packet filters that (1) force uplink traffic from existing data sessions between the UE and the application in the source local DN into the N9 forwarding tunnel towards the source UL CL; and (2) force any traffic related to the application in the target local DN to go to the new local DN via the target PSA.

25 [0010] The SMF may send a late notification to the AF to inform the AF about the data network access identifier (DNAI) change, as described in TS 23.502 clause 4.3.6.3. This notification can be used by the AF, for example, to trigger mechanisms in the source local DN to redirect the ongoing traffic sessions towards an application in the target local DN. The SMF can also send a late notification to the target AF instance if associated with this target local DN.

30

[0011] According to TS 23.502 clause 4.3.6.3, the specific mechanisms for traffic redirection are considered out of scope of that specification. When session continuity upon UL CL relocation is used, the AF can also trigger mechanisms such as, for example, IP-level or HTTP-level redirection, by which the traffic is redirected towards the application in the target local DN.

5 Based on this redirection the UE starts using a new destination IP address which leads the target UL CL to force the traffic towards PSA3.

Summary

[0012] Some exemplary embodiments relate to a method performed by a source application server handler for transitioning a UE to a new application server in response to a mobility event. The method includes receiving an application ID (AC-ID) associated with an application client for a user equipment (UE); receiving a mobility event notification including a UE ID of the UE and a target data network access identifier (DNAI) to indicate a target edge data network to which a transition of a data connection for the application client is to be performed; encoding an outgoing transition request for transmission to a source application server to indicate the transition of the data connection from the source application server; and encoding an incoming transition request for transmission to a target application server handler (ASH) of the target edge data network to indicate the transition of the data connection to the target edge data network.

20 [0013] In some exemplary embodiments, the method described above is performed by an apparatus that is implemented in or employed by a server.

[0014] Other exemplary embodiments relate to a method performed by a source application server for transitioning a UE to a new application server in response to a mobility event. The method includes receiving an outgoing transition request from a source application server handler (ASH) of a source Edge data network to indicate a transition of a data connection for an application run by a UE from the source Edge data network to a target Edge data network, wherein the outgoing transition request includes an application ID (AC-ID) of the application; and performing, based on the outgoing transition request, context mirroring with a target application server of the target application network to provide the UE context information associated with the application to the target application network.

[0015] In some exemplary embodiments, the method described above is performed by an apparatus that is implemented in or employed by a server.

5 **Brief Description of the Drawings**

[0016] Figure 1 illustrates an example of architecture with N9 forwarding tunnel between source and target UL CL according to various exemplary embodiments.

10 [0017] Figure 2 illustrates an example architecture of a system of a network according to various exemplary embodiments.

[0018] Figure 3 illustrates an example architecture of a system including a first core network (CN) according to various exemplary embodiments.

15 [0019] Figure 4 an architecture of a system including a second CN according to various exemplary embodiments.

[0020] Figure 5 illustrates an example of infrastructure equipment according to various exemplary embodiments.

20

[0021] Figure 6 illustrates an example of a platform according to various exemplary embodiments.

25 [0022] Figure 7 illustrates example components of baseband circuitry and radio front end modules (RFEM) according to various exemplary embodiments.

[0023] Figure 8 illustrates components of a core network according to various exemplary embodiments.

30 [0024] Figure 9 is a block diagram illustrating components of a system to support network function virtualization (NFV) according to various exemplary embodiments.

[0025] Figure 10 is a block diagram illustrating components able to read instructions from a machine-readable or computer-readable medium (e.g., a non-transitory machine-readable storage medium) and perform any one or more of the methodologies discussed herein.

5 [0026] Figure 11 illustrates various protocol functions that may be implemented in a wireless communication device according to various exemplary embodiments.

10 [0027] Figure 12 is a signaling diagram illustrating the flow of information for enabling application clients to experience service continuity while switching application servers when a change in Edge Data Network is performed according to various exemplary embodiments.

Detailed Description

15 [0028] The following detailed description refers to the accompanying drawings. The same reference numbers may be used in different drawings to identify the same or similar elements. In the following description, for purposes of explanation and not limitation, specific details are set forth such as particular structures, architectures, interfaces, techniques, etc. in order to provide a thorough understanding of the various aspects of various embodiments. However, it will be apparent to those skilled in the art having the benefit of the present disclosure that the various

20 aspects of the various embodiments may be practiced in other examples that depart from these specific details. In certain instances, descriptions of well-known devices, circuits, and methods are omitted so as not to obscure the description of the various embodiments with unnecessary detail. For the purposes of the present document, the phrase “A or B” means (A), (B), or (A and B).

25 [0029] The exemplary embodiments may be further understood with reference to the following description and the related appended drawings, wherein like elements are provided with the same reference numerals. The exemplary embodiments describe a device, system and method for enabling service continuity in an edge computing environment.

30

[0030] In this disclosure, the following definitions are used:

- Edge Computing: A concept, as described in 3GPP TS 23.501 [2], that enables operator and 3rd party services to be hosted close to the UE's access point of attachment, to achieve an efficient service delivery through the reduced end-to-end latency and load on the transport network.
- Edge Data Network: A data network, which includes a set of functions to support Edge Computing.
- DN Access Identifier (DNAI): Identifier of a user plane access to one or more DN(s) where applications are deployed.

[0031] The current 3GPP specifications focus on the "lower layer" aspects of session continuity upon relocation of the Uplink Classifier functionality from one Edge data network to another. The "upper layer" mechanism for traffic redirection is currently missing from 3GPP specifications.

[0032] Without a mechanism for traffic redirection, application clients connected to application servers in the source Edge data network, will continue to be connected to these servers after a mobility event. This may introduce inefficiencies of traffic routing, when the new location of the UE is topologically far from the old location of the application servers, and there are mirrors of these servers in the target Edge data network that is topologically closer to the UE.

[0033] This disclosure describes exemplary mechanisms for the AF to notify the UE about the mobility event and provide identification information (e.g. fully qualified domain name (FQDN), IP address, URL, or any other identification) of the preferred Application Server. It further provides exemplary mechanisms to trigger specific Application clients so they can act on this information and modify their connection to the new preferred servers.

[0034] The exemplary embodiments provide a handler that is installed on UEs that wish to provide this service to application clients. This handler connects to a corresponding server handler in the network that provides mobility-related information upon UE mobility. The handler

in the UE exposes application programming interfaces (APIs) that are used by application clients for registering for mobility-related triggering and information.

[0035] In the following disclosure, it may be considered that:

- 5
- an Application Server Handler is deployed in the Edge Data Network hosting one or more Application Servers.
 - an Application Client Handler is deployed in the UE hosting one or more Application Clients
- 10
- 5GC Core Network is as indicated in TS 23.501/23.502/23.503.
 - The change for the user plane path from source Edge Data Network to target Edge Data Network will result in the change from an old Application Server to a new Application server. The UE has established a PDU session with an appropriate Edge Data Network. The appropriate Edge Data Network may be selected based on any suitable criteria.
- 15
- The Initial address information for the Application Server Handler and the Application Server in the Edge Data Network are assumed as known to the Application Client Handler, (e.g. based on configuration). The serving Application Server of the application in the Edge Data Network may be selected and provided to the Application Client Handler by any suitable means.
- 20
- The Application function (AF) is interfacing with the 5G NR network and the Application Server Handler can obtain information from the 5G NR network via the AF. The Application Server Handler may interact with AF or act as an AF.
 - The Application Server Handler has subscribed to notification service via AF to the network functions in 5G Core Network for the Mobility event with a condition of a
- 25
- change of DNAI, or out of its serving geographic area. When the mobility event occurs, a notification is generated and sent to the Application Server Handler.

Systems and Implementations

- 30 [0036] Figure 2 illustrates an example architecture of a system 200 of a network in accordance with various exemplary embodiments. The following description is provided for an example system 200 that operates in conjunction with the 5G NR system standards as provided by 3GPP

technical specifications. However, the exemplary embodiments are not limited in this regard and the described embodiments may apply to other networks that benefit from the principles described herein, such as legacy (e.g. LTE) 3GPP systems, future 3GPP systems (e.g., Sixth Generation (6G) systems), IEEE 802.16 protocols (e.g., WMAN, WiMAX, etc.), or the like.

5

[0037] As shown by Figure 2, the system 200 includes UE 201a and UE 201b (collectively referred to as “UEs 201” or “UE 201”). In this example, UEs 201 are illustrated as smartphones (e.g., handheld touchscreen mobile computing devices connectable to one or more cellular networks), but may also comprise any mobile or non-mobile computing device, such as
10 consumer electronics devices, cellular phones, smartphones, feature phones, tablet computers, wearable computer devices, personal digital assistants (PDAs), pagers, wireless handsets, desktop computers, laptop computers, in-vehicle infotainment (IVI), in-car entertainment (ICE) devices, an Instrument Cluster (IC), head-up display (HUD) devices, onboard diagnostic (OBD) devices, dashtop mobile equipment (DME), mobile data terminals (MDTs), Electronic Engine
15 Management System (EEMS), electronic/engine control units (ECUs), electronic/engine control modules (ECMs), embedded systems, microcontrollers, control modules, engine management systems (EMS), networked or “smart” appliances, MTC devices, M2M, IoT devices, and/or the like.

20 **[0038]** In some embodiments, any of the UEs 201 may be IoT UEs, which may comprise a network access layer designed for low-power IoT applications utilizing short-lived UE connections. An IoT UE can utilize technologies such as M2M or MTC for exchanging data with an MTC server or device via a PLMN, ProSe or D2D communication, sensor networks, or IoT networks. The M2M or MTC exchange of data may be a machine-initiated exchange of data. An
25 IoT network describes interconnecting IoT UEs, which may include uniquely identifiable embedded computing devices (within the Internet infrastructure), with short-lived connections. The IoT UEs may execute background applications (e.g., keep-alive messages, status updates, etc.) to facilitate the connections of the IoT network.

30 **[0039]** The UEs 201 may be configured to connect, for example, communicatively couple, with an or RAN 210. In some embodiments, the RAN 210 may be a 5G NR RAN, while in other

embodiments the RAN 210 may be an E-UTRAN, or a legacy RAN, such as a UTRAN or GERAN. As used herein, the term “5G NR RAN” or the like may refer to a RAN 210 that operates in an NR or 5G system 200, and the term “E-UTRAN” or the like may refer to a RAN 210 that operates in an LTE or 4G system 200. The UEs 201 utilize connections (or channels) 203 and 204, respectively, each of which comprises a physical communications interface or layer (discussed in further detail below).

[0040] In this example, the connections 203 and 204 are illustrated as an air interface to enable communicative coupling, and can be consistent with cellular communications protocols, such as a GSM protocol, a CDMA network protocol, a PTT protocol, a POC protocol, a UMTS protocol, a 3GPP LTE protocol, a 5G protocol, a NR protocol, and/or any of the other communications protocols discussed herein. In some embodiments, the UEs 201 may directly exchange communication data via a ProSe interface 205. The ProSe interface 205 may alternatively be referred to as a SL interface 205 and may comprise one or more logical channels, including but not limited to a PSCCH, a PSSCH, a PSDCH, and a PSBCH.

[0041] The UE 201b is shown to be configured to access an AP 206 (also referred to as “WLAN node 206,” “WLAN 206,” “WLAN Termination 206,” “WT 206” or the like) via connection 207. The connection 207 can comprise a local wireless connection, such as a connection consistent with any IEEE 802.11 protocol, wherein the AP 206 would comprise a wireless fidelity (Wi-Fi®) router. In this example, the AP 206 is shown to be connected to the Internet without connecting to the core network of the wireless system (described in further detail below). In various embodiments, the UE 201b, RAN 210, and AP 206 may be configured to utilize LWA operation and/or LWIP operation. The LWA operation may involve the UE 201b in RRC_CONNECTED being configured by a RAN node 211a-b to utilize radio resources of LTE and WLAN. LWIP operation may involve the UE 201b using WLAN radio resources (e.g., connection 207) via IPsec protocol tunneling to authenticate and encrypt packets (e.g., IP packets) sent over the connection 207. IPsec tunneling may include encapsulating the entirety of original IP packets and adding a new packet header, thereby protecting the original header of the IP packets.

[0042] The RAN 210 can include one or more AN nodes or RAN nodes 211a and 211b (collectively referred to as “RAN nodes 211” or “RAN node 211”) that enable the connections 203 and 204. As used herein, the terms “access node,” “access point,” or the like may describe equipment that provides the radio baseband functions for data and/or voice connectivity between a network and one or more users. These access nodes can be referred to as BS, gNBs, RAN nodes, eNBs, NodeBs, RSUs, TRxPs or TRPs, and so forth, and can comprise ground stations (e.g., terrestrial access points) or satellite stations providing coverage within a geographic area (e.g., a cell). As used herein, the term “5G NR RAN node” or the like may refer to a RAN node 211 that operates in an NR or 5G system 200 (for example, a gNB), and the term “E-UTRAN node” or the like may refer to a RAN node 211 that operates in an LTE or 4G system 200 (e.g., an eNB). According to various embodiments, the RAN nodes 211 may be implemented as one or more of a dedicated physical device such as a macrocell base station, and/or a low power (LP) base station for providing femtocells, picocells or other like cells having smaller coverage areas, smaller user capacity, or higher bandwidth compared to macrocells.

[0043] In some embodiments, all or parts of the RAN nodes 211 may be implemented as one or more software entities running on server computers as part of a virtual network, which may be referred to as a CRAN and/or a virtual baseband unit pool (vBBUP). In these embodiments, the CRAN or vBBUP may implement a RAN function split, such as a PDCP split wherein RRC and PDCP layers are operated by the CRAN/vBBUP and other L2 protocol entities are operated by individual RAN nodes 211; a MAC/PHY split wherein RRC, PDCP, RLC, and MAC layers are operated by the CRAN/vBBUP and the PHY layer is operated by individual RAN nodes 211; or a “lower PHY” split wherein RRC, PDCP, RLC, MAC layers and upper portions of the PHY layer are operated by the CRAN/vBBUP and lower portions of the PHY layer are operated by individual RAN nodes 211. This virtualized framework allows the freed-up processor cores of the RAN nodes 211 to perform other virtualized applications. In some implementations, an individual RAN node 211 may represent individual gNB-DUs that are connected to a gNB-CU via individual F1 interfaces (not shown by Figure 2). In these implementations, the gNB-DUs may include one or more remote radio heads or RFEMs (see, e.g., Figure 5), and the gNB-CU may be operated by a server that is located in the RAN 210 (not shown) or by a server pool in a similar manner as the CRAN/vBBUP. Additionally or alternatively, one or more of the RAN

nodes 211 may be next generation eNBs (ng-eNBs), which are RAN nodes that provide E-UTRA user plane and control plane protocol terminations toward the UEs 201, and are connected to a 5GC (e.g., CN 420 of Figure 4) via an NG interface (discussed infra).

5 [0044] In V2X scenarios one or more of the RAN nodes 211 may be or act as RSUs. The term “Road Side Unit” or “RSU” may refer to any transportation infrastructure entity used for V2X communications. An RSU may be implemented in or by a suitable RAN node or a stationary (or relatively stationary) UE, where an RSU implemented in or by a UE may be referred to as a “UE-type RSU,” an RSU implemented in or by an eNB may be referred to as an “eNB-type
10 RSU,” an RSU implemented in or by a gNB may be referred to as a “gNB-type RSU,” and the like. In one example, an RSU is a computing device coupled with radio frequency circuitry located on a roadside that provides connectivity support to passing vehicle UEs 201 (vUEs 201). The RSU may also include internal data storage circuitry to store intersection map geometry, traffic statistics, media, as well as applications/software to sense and control ongoing vehicular
15 and pedestrian traffic. The RSU may operate on the 5.9 GHz Direct Short Range Communications (DSRC) band to provide very low latency communications required for high speed events, such as crash avoidance, traffic warnings, and the like. Additionally or alternatively, the RSU may operate on the cellular V2X band to provide the aforementioned low latency communications, as well as other cellular communications services. Additionally or
20 alternatively, the RSU may operate as a Wi-Fi hotspot (2.4 GHz band) and/or provide connectivity to one or more cellular networks to provide uplink and downlink communications. The computing device(s) and some or all of the radiofrequency circuitry of the RSU may be packaged in a weatherproof enclosure suitable for outdoor installation, and may include a network interface controller to provide a wired connection (e.g., Ethernet) to a traffic signal
25 controller and/or a backhaul network.

[0045] Any of the RAN nodes 211 can terminate the air interface protocol and can be the first point of contact for the UEs 201. In some embodiments, any of the RAN nodes 211 can fulfill various logical functions for the RAN 210 including, but not limited to, radio network controller
30 (RNC) functions such as radio bearer management, uplink and downlink dynamic radio resource management and data packet scheduling, and mobility management.

[0046] In some embodiments, the UEs 201 can be configured to communicate using OFDM communication signals with each other or with any of the RAN nodes 211 over a multicarrier communication channel in accordance with various communication techniques, such as, but not limited to, an OFDMA communication technique (e.g., for downlink communications) or a SC-FDMA communication technique (e.g., for uplink and ProSe or sidelink communications), although the scope of the embodiments is not limited in this respect. The OFDM signals can comprise a plurality of orthogonal subcarriers.

[0047] In some embodiments, a downlink resource grid can be used for downlink transmissions from any of the RAN nodes 211 to the UEs 201, while uplink transmissions can utilize similar techniques. The grid can be a time-frequency grid, called a resource grid or time-frequency resource grid, which is the physical resource in the downlink in each slot. Such a time-frequency plane representation is a common practice for OFDM systems, which makes it intuitive for radio resource allocation. Each column and each row of the resource grid corresponds to one OFDM symbol and one OFDM subcarrier, respectively. The duration of the resource grid in the time domain corresponds to one slot in a radio frame. The smallest time-frequency unit in a resource grid is denoted as a resource element. Each resource grid comprises a number of resource blocks, which describe the mapping of certain physical channels to resource elements. Each resource block comprises a collection of resource elements; in the frequency domain, this may represent the smallest quantity of resources that currently can be allocated. There are several different physical downlink channels that are conveyed using such resource blocks.

[0048] According to various embodiments, the UEs 201 and the RAN nodes 211 communicate data (for example, transmit and receive) data over a licensed medium (also referred to as the “licensed spectrum” and/or the “licensed band”) and an unlicensed shared medium (also referred to as the “unlicensed spectrum” and/or the “unlicensed band”). The licensed spectrum may include channels that operate in the frequency range of approximately 400 MHz to approximately 3.8 GHz, whereas the unlicensed spectrum may include the 5 GHz band.

[0049] To operate in the unlicensed spectrum, the UEs 201 and the RAN nodes 211 may operate using LAA, eLAA, and/or feLAA mechanisms. In these implementations, the UEs 201 and the RAN nodes 211 may perform one or more known medium-sensing operations and/or carrier-sensing operations in order to determine whether one or more channels in the unlicensed spectrum is unavailable or otherwise occupied prior to transmitting in the unlicensed spectrum. The medium/carrier sensing operations may be performed according to a listen-before-talk (LBT) protocol.

[0050] LBT is a mechanism whereby equipment (for example, UEs 201 RAN nodes 211, etc.) senses a medium (for example, a channel or carrier frequency) and transmits when the medium is sensed to be idle (or when a specific channel in the medium is sensed to be unoccupied). The medium sensing operation may include CCA, which utilizes at least ED to determine the presence or absence of other signals on a channel in order to determine if a channel is occupied or clear. This LBT mechanism allows cellular/LAA networks to coexist with incumbent systems in the unlicensed spectrum and with other LAA networks. ED may include sensing RF energy across an intended transmission band for a period of time and comparing the sensed RF energy to a predefined or configured threshold.

[0051] Typically, the incumbent systems in the 5 GHz band are WLANs based on IEEE 802.11 technologies. WLAN employs a contention-based channel access mechanism, called CSMA/CA. Here, when a WLAN node (e.g., a mobile station (MS) such as UE 201, AP 206, or the like) intends to transmit, the WLAN node may first perform CCA before transmission. Additionally, a backoff mechanism is used to avoid collisions in situations where more than one WLAN node senses the channel as idle and transmits at the same time. The backoff mechanism may be a counter that is drawn randomly within the CWS, which is increased exponentially upon the occurrence of collision and reset to a minimum value when the transmission succeeds. The LBT mechanism designed for LAA is somewhat similar to the CSMA/CA of WLAN. In some implementations, the LBT procedure for DL or UL transmission bursts including PDSCH or PUSCH transmissions, respectively, may have an LAA contention window that is variable in length between X and Y ECCA slots, where X and Y are minimum and maximum values for the CWSs for LAA. In one example, the minimum CWS for an LAA transmission may be 9

microseconds (μs); however, the size of the CWS and a MCOT (for example, a transmission burst) may be based on governmental regulatory requirements.

[0052] The LAA mechanisms are built upon CA technologies of LTE-Advanced systems. In CA, each aggregated carrier is referred to as a CC. A CC may have a bandwidth of 1.4, 3, 5, 10, 15 or 20 MHz and a maximum of five CCs can be aggregated, and therefore, a maximum aggregated bandwidth is 100 MHz. In FDD systems, the number of aggregated carriers can be different for DL and UL, where the number of UL CCs is equal to or lower than the number of DL component carriers. In some cases, individual CCs can have a different bandwidth than other CCs. In TDD systems, the number of CCs as well as the bandwidths of each CC is usually the same for DL and UL.

[0053] CA also comprises individual serving cells to provide individual CCs. The coverage of the serving cells may differ, for example, because CCs on different frequency bands will experience different pathloss. A primary service cell or PCell may provide a PCC for both UL and DL, and may handle RRC and NAS related activities. The other serving cells are referred to as SCells, and each SCell may provide an individual SCC for both UL and DL. The SCCs may be added and removed as required, while changing the PCC may require the UE 201 to undergo a handover. In LAA, eLAA, and feLAA, some or all of the SCells may operate in the unlicensed spectrum (referred to as "LAA SCells"), and the LAA SCells are assisted by a PCell operating in the licensed spectrum. When a UE is configured with more than one LAA SCell, the UE may receive UL grants on the configured LAA SCells indicating different PUSCH starting positions within a same subframe.

[0054] The PDSCH carries user data and higher-layer signaling to the UEs 201. The PDCCH carries information about the transport format and resource allocations related to the PDSCH channel, among other things. It may also inform the UEs 201 about the transport format, resource allocation, and HARQ information related to the uplink shared channel. Typically, downlink scheduling (assigning control and shared channel resource blocks to the UE 201b within a cell) may be performed at any of the RAN nodes 211 based on channel quality information fed back

from any of the UEs 201. The downlink resource assignment information may be sent on the PDCCH used for (e.g., assigned to) each of the UEs 201.

[0055] The PDCCH uses CCEs to convey the control information. Before being mapped to
5 resource elements, the PDCCH complex-valued symbols may first be organized into quadruplets, which may then be permuted using a sub-block interleaver for rate matching. Each PDCCH may be transmitted using one or more of these CCEs, where each CCE may correspond to nine sets of four physical resource elements known as REGs. Four Quadrature Phase Shift Keying (QPSK) symbols may be mapped to each REG. The PDCCH can be transmitted using one or more CCEs,
10 depending on the size of the DCI and the channel condition. There can be four or more different PDCCH formats defined in LTE with different numbers of CCEs (e.g., aggregation level, L=1, 2, 4, or 8).

[0056] Some embodiments may use concepts for resource allocation for control channel
15 information that are an extension of the above-described concepts. For example, some embodiments may utilize an EPDCCH that uses PDSCH resources for control information transmission. The EPDCCH may be transmitted using one or more ECCEs. Similar to above, each ECCE may correspond to nine sets of four physical resource elements known as an EREGs. An ECCE may have other numbers of EREGs in some situations.

[0057] The RAN nodes 211 may be configured to communicate with one another via interface
20 212. In some embodiments where the system 200 is an LTE system (e.g., when CN 220 is an EPC 320 as in Figure 3), the interface 212 may be an X2 interface 212. The X2 interface may be defined between two or more RAN nodes 211 (e.g., two or more eNBs and the like) that connect
25 to EPC 220, and/or between two eNBs connecting to EPC 220. In some implementations, the X2 interface may include an X2 user plane interface (X2-U) and an X2 control plane interface (X2-C). The X2-U may provide flow control mechanisms for user data packets transferred over the X2 interface, and may be used to communicate information about the delivery of user data
between eNBs. For example, the X2-U may provide specific sequence number information for
30 user data transferred from a MeNB to an SeNB; information about successful in sequence delivery of PDCP PDUs to a UE 201 from an SeNB for user data; information of PDCP PDUs

that were not delivered to a UE 201; information about a current minimum desired buffer size at the SeNB for transmitting to the UE user data; and the like. The X2-C may provide intra-LTE access mobility functionality, including context transfers from source to target eNBs, user plane transport control, etc.; load management functionality; as well as inter-cell interference
5 coordination functionality.

[0058] In some embodiments where the system 200 is a 5G or NR system (e.g., when CN 220 is an 5GC 420 as in Figure 4), the interface 212 may be an Xn interface 212. The Xn interface is defined between two or more RAN nodes 211 (e.g., two or more gNBs and the like) that connect
10 to 5GC 220, between a RAN node 211 (e.g., a gNB) connecting to 5GC 220 and an eNB, and/or between two eNBs connecting to 5GC 220. In some implementations, the Xn interface may include an Xn user plane (Xn-U) interface and an Xn control plane (Xn-C) interface. The Xn-U may provide non-guaranteed delivery of user plane PDUs and support/provide data forwarding and flow control functionality. The Xn-C may provide management and error handling
15 functionality, functionality to manage the Xn-C interface; mobility support for UE 201 in a connected mode (e.g., CM-CONNECTED) including functionality to manage the UE mobility for connected mode between one or more RAN nodes 211. The mobility support may include context transfer from an old (source) serving RAN node 211 to new (target) serving RAN node 211; and control of user plane tunnels between old (source) serving RAN node 211 to new
20 (target) serving RAN node 211. A protocol stack of the Xn-U may include a transport network layer built on Internet Protocol (IP) transport layer, and a GTP-U layer on top of a UDP and/or IP layer(s) to carry user plane PDUs. The Xn-C protocol stack may include an application layer signaling protocol (referred to as Xn Application Protocol (Xn-AP)) and a transport network layer that is built on SCTP. The SCTP may be on top of an IP layer, and may provide the
25 guaranteed delivery of application layer messages. In the transport IP layer, point-to-point transmission is used to deliver the signaling PDUs. In other implementations, the Xn-U protocol stack and/or the Xn-C protocol stack may be same or similar to the user plane and/or control plane protocol stack(s) shown and described herein.

[0059] The RAN 210 is shown to be communicatively coupled to a core network—in this
30 embodiment, core network (CN) 220. The CN 220 may comprise a plurality of network elements

222, which are configured to offer various data and telecommunications services to customers/subscribers (e.g., users of UEs 201) who are connected to the CN 220 via the RAN 210. The components of the CN 220 may be implemented in one physical node or separate physical nodes including components to read and execute instructions from a machine-readable or computer-readable medium (e.g., a non-transitory machine-readable storage medium). In some embodiments, NFV may be utilized to virtualize any or all of the above-described network node functions via executable instructions stored in one or more computer-readable storage mediums (described in further detail below). A logical instantiation of the CN 220 may be referred to as a network slice, and a logical instantiation of a portion of the CN 220 may be referred to as a network sub-slice. NFV architectures and infrastructures may be used to virtualize one or more network functions, alternatively performed by proprietary hardware, onto physical resources comprising a combination of industry-standard server hardware, storage hardware, or switches. In other words, NFV systems can be used to execute virtual or reconfigurable implementations of one or more EPC components/functions.

15

[0060] Generally, the application server 230 may be an element offering applications that use IP bearer resources with the core network (e.g., UMTS PS domain, LTE PS data services, etc.). The application server 230 can also be configured to support one or more communication services (e.g., VoIP sessions, PTT sessions, group communication sessions, social networking services, etc.) for the UEs 201 via the EPC 220.

20

[0061] In some embodiments, the CN 220 may be a 5GC (referred to as “5GC 220” or the like), and the RAN 210 may be connected with the CN 220 via an NG interface 213. In some embodiments, the NG interface 213 may be split into two parts, an NG user plane (NG-U) interface 214, which carries traffic data between the RAN nodes 211 and a UPF, and the S1 control plane (NG-C) interface 215, which is a signaling interface between the RAN nodes 211 and AMFs. Embodiments where the CN 220 is a 5GC 220 are discussed in more detail with regard to Figure 4.

25

[0062] In some embodiments, the CN 220 may be a 5G CN (referred to as “5GC 220” or the like), while in other embodiments, the CN 220 may be an EPC). Where CN 220 is an EPC (referred to as “EPC 220” or the like), the RAN 210 may be connected with the CN 220 via an

30

S1 interface 213. In some embodiments, the S1 interface 213 may be split into two parts, an S1 user plane (S1-U) interface 214, which carries traffic data between the RAN nodes 211 and the S-GW, and the S1-MME interface 215, which is a signaling interface between the RAN nodes 211 and MMEs.

5

[0063] Figure 3 illustrates an example architecture of a system 300 including a first CN 320, in accordance with various embodiments. In this example, system 300 may implement the LTE standard wherein the CN 320 is an EPC 320 that corresponds with CN 220 of Figure 2.

10 Additionally, the UE 301 may be the same or similar as the UEs 201 of Figure 2, and the E-UTRAN 310 may be a RAN that is the same or similar to the RAN 210 of Figure 2, and which may include RAN nodes 211 discussed previously. The CN 320 may comprise MMEs 321, an S-GW 322, a P-GW 323, a HSS 324, and a SGSN 325.

15 **[0064]** The MMEs 321 may be similar in function to the control plane of legacy SGSN, and may implement MM functions to keep track of the current location of a UE 301. The MMEs 321 may perform various MM procedures to manage mobility aspects in access such as gateway selection and tracking area list management. MM (also referred to as “EPS MM” or “EMM” in E-UTRAN systems) may refer to all applicable procedures, methods, data storage, etc. that are used to
20 maintain knowledge about a present location of the UE 301, provide user identity confidentiality, and/or perform other like services to users/subscribers. Each UE 301 and the MME 321 may include an MM or EMM sublayer, and an MM context may be established in the UE 301 and the MME 321 when an attach procedure is successfully completed. The MM context may be a data structure or database object that stores MM-related information of the UE 301. The MMEs 321
25 may be coupled with the HSS 324 via an S6a reference point, coupled with the SGSN 325 via an S3 reference point, and coupled with the S-GW 322 via an S11 reference point.

[0065] The SGSN 325 may be a node that serves the UE 301 by tracking the location of an individual UE 301 and performing security functions. In addition, the SGSN 325 may perform
30 Inter-EPC node signaling for mobility between 2G/3G and E-UTRAN 3GPP access networks; PDN and S-GW selection as specified by the MMEs 321; handling of UE 301 time zone

functions as specified by the MMEs 321; and MME selection for handovers to E-UTRAN 3GPP access network. The S3 reference point between the MMEs 321 and the SGSN 325 may enable user and bearer information exchange for inter-3GPP access network mobility in idle and/or active states.

5

[0066] The HSS 324 may comprise a database for network users, including subscription-related information to support the network entities' handling of communication sessions. The EPC 320 may comprise one or several HSSs 324, depending on the number of mobile subscribers, on the capacity of the equipment, on the organization of the network, etc. For example, the HSS 324 can provide support for routing/roaming, authentication, authorization, naming/addressing resolution, location dependencies, etc. An S6a reference point between the HSS 324 and the MMEs 321 may enable transfer of subscription and authentication data for authenticating/authorizing user access to the EPC 320 between HSS 324 and the MMEs 321.

10

15

[0067] The S-GW 322 may terminate the S1 interface 213 ("S1-U" in Figure 3) toward the RAN 310, and routes data packets between the RAN 310 and the EPC 320. In addition, the S-GW 322 may be a local mobility anchor point for inter-RAN node handovers and also may provide an anchor for inter-3GPP mobility. Other responsibilities may include lawful intercept, charging, and some policy enforcement. The S11 reference point between the S-GW 322 and the MMEs 321 may provide a control plane between the MMEs 321 and the S-GW 322. The S-GW 322 may be coupled with the P-GW 323 via an S5 reference point.

20

25

[0068] The P-GW 323 may terminate an SGi interface toward a PDN 330. The P-GW 323 may route data packets between the EPC 320 and external networks such as a network including the application server 230 (alternatively referred to as an "AF") via an IP interface 225 (see e.g., Figure 2). In some embodiments, the P-GW 323 may be communicatively coupled to an application server (application server 230 of Figure 2 or PDN 330 in Figure 3) via an IP communications interface 225 (see, e.g., Figure 2). The S5 reference point between the P-GW 323 and the S-GW 322 may provide user plane tunneling and tunnel management between the P-GW 323 and the S-GW 322. The S5 reference point may also be used for S-GW 322 relocation due to UE 301 mobility and if the S-GW 322 needs to connect to a non-located P-GW 323 for

30

the required PDN connectivity. The P-GW 323 may further include a node for policy enforcement and charging data collection (e.g., PCEF (not shown)). Additionally, the SGI reference point between the P-GW 323 and the packet data network (PDN) 330 may be an operator external public, a private PDN, or an intra operator packet data network, for example, for provision of IMS services. The P-GW 323 may be coupled with a PCRF 326 via a Gx reference point.

[0069] PCRF 326 is the policy and charging control element of the EPC 320. In a non-roaming scenario, there may be a single PCRF 326 in the Home Public Land Mobile Network (HPLMN) associated with a UE 301's Internet Protocol Connectivity Access Network (IP-CAN) session. In a roaming scenario with local breakout of traffic, there may be two PCRFs associated with a UE 301's IP-CAN session, a Home PCRF (H-PCRF) within an HPLMN and a Visited PCRF (V-PCRF) within a Visited Public Land Mobile Network (VPLMN). The PCRF 326 may be communicatively coupled to the application server 330 via the P-GW 323. The application server 330 may signal the PCRF 326 to indicate a new service flow and select the appropriate QoS and charging parameters. The PCRF 326 may provision this rule into a PCEF (not shown) with the appropriate TFT and QCI, which commences the QoS and charging as specified by the application server 330. The Gx reference point between the PCRF 326 and the P-GW 323 may allow for the transfer of QoS policy and charging rules from the PCRF 326 to PCEF in the P-GW 323. An Rx reference point may reside between the PDN 330 (or "AF 330") and the PCRF 326.

[0070] Figure 4 illustrates an architecture of a system 400 including a second CN 420 in accordance with various embodiments. The system 400 is shown to include a UE 401, which may be the same or similar to the UEs 201 and UE 301 discussed previously; a (R)AN 410, which may be the same or similar to the RAN 210 and RAN 310 discussed previously, and which may include RAN nodes 211 discussed previously; and a DN 403, which may be, for example, operator services, Internet access or 3rd party services; and a 5GC 420. The 5GC 420 may include an AUSF 422; an AMF 421; a SMF 424; a NEF 423; a PCF 426; a NRF 425; a UDM 427; an AF 428; a UPF 402; and a NSSF 429.

30

[0071] The UPF 402 may act as an anchor point for intra-RAT and inter-RAT mobility, an external PDU session point of interconnect to DN 403, and a branching point to support multi-homed PDU session. The UPF 402 may also perform packet routing and forwarding, perform packet inspection, enforce the user plane part of policy rules, lawfully intercept packets (UP
5 collection), perform traffic usage reporting, perform QoS handling for a user plane (e.g., packet filtering, gating, UL/DL rate enforcement), perform Uplink Traffic verification (e.g., SDF to QoS flow mapping), transport level packet marking in the uplink and downlink, and perform downlink packet buffering and downlink data notification triggering. UPF 402 may include an uplink classifier to support routing traffic flows to a data network. The DN 403 may represent
10 various network operator services, Internet access, or third party services. DN 403 may include, or be similar to, application server 230 discussed previously. The UPF 402 may interact with the SMF 424 via an N4 reference point between the SMF 424 and the UPF 402.

[0072] The AUSF 422 may store data for authentication of UE 401 and handle authentication-
15 related functionality. The AUSF 422 may facilitate a common authentication framework for various access types. The AUSF 422 may communicate with the AMF 421 via an N12 reference point between the AMF 421 and the AUSF 422; and may communicate with the UDM 427 via an N13 reference point between the UDM 427 and the AUSF 422. Additionally, the AUSF 422 may exhibit an Nausf service-based interface.

[0073] The AMF 421 may be responsible for registration management (e.g., for registering UE
20 401, etc.), connection management, reachability management, mobility management, and lawful interception of AMF-related events, and access authentication and authorization. The AMF 421 may be a termination point for the an N11 reference point between the AMF 421 and the SMF
25 424. The AMF 421 may provide transport for SM messages between the UE 401 and the SMF 424, and act as a transparent proxy for routing SM messages. AMF 421 may also provide transport for SMS messages between UE 401 and an SMSF (not shown by Figure 4). AMF 421 may act as SEAF, which may include interaction with the AUSF 422 and the UE 401, receipt of an intermediate key that was established as a result of the UE 401 authentication process. Where
30 USIM based authentication is used, the AMF 421 may retrieve the security material from the AUSF 422. AMF 421 may also include a SCM function, which receives a key from the SEA that

it uses to derive access-network specific keys. Furthermore, AMF 421 may be a termination point of a RAN CP interface, which may include or be an N2 reference point between the (R)AN 410 and the AMF 421; and the AMF 421 may be a termination point of NAS (N1) signalling, and perform NAS ciphering and integrity protection.

5

[0074] AMF 421 may also support NAS signalling with a UE 401 over an N3 IWF interface. The N3IWF may be used to provide access to untrusted entities. N3IWF may be a termination point for the N2 interface between the (R)AN 410 and the AMF 421 for the control plane, and may be a termination point for the N3 reference point between the (R)AN 410 and the UPF 402
10 for the user plane. As such, the AMF 421 may handle N2 signalling from the SMF 424 and the AMF 421 for PDU sessions and QoS, encapsulate/de-encapsulate packets for IPsec and N3 tunnelling, mark N3 user-plane packets in the uplink, and enforce QoS corresponding to N3 packet marking taking into account QoS requirements associated with such marking received over N2. N3IWF may also relay uplink and downlink control-plane NAS signalling between the
15 UE 401 and AMF 421 via an N1 reference point between the UE 401 and the AMF 421, and relay uplink and downlink user-plane packets between the UE 401 and UPF 402. The N3IWF also provides mechanisms for IPsec tunnel establishment with the UE 401. The AMF 421 may exhibit an Namf service-based interface, and may be a termination point for an N14 reference point between two AMFs 421 and an N17 reference point between the AMF 421 and a 5G-EIR
20 (not shown by Figure 4).

[0075] The UE 401 may need to register with the AMF 421 in order to receive network services. RM is used to register or deregister the UE 401 with the network (e.g., AMF 421), and establish a UE context in the network (e.g., AMF 421). The UE 401 may operate in an RM-
25 REGISTERED state or an RM-DEREGISTERED state. In the RM-DEREGISTERED state, the UE 401 is not registered with the network, and the UE context in AMF 421 holds no valid location or routing information for the UE 401 so the UE 401 is not reachable by the AMF 421. In the RM-REGISTERED state, the UE 401 is registered with the network, and the UE context in AMF 421 may hold a valid location or routing information for the UE 401 so the UE 401 is
30 reachable by the AMF 421. In the RM-REGISTERED state, the UE 401 may perform mobility Registration Update procedures, perform periodic Registration Update procedures triggered by

expiration of the periodic update timer (e.g., to notify the network that the UE 401 is still active), and perform a Registration Update procedure to update UE capability information or to re-negotiate protocol parameters with the network, among others.

5 [0076] The AMF 421 may store one or more RM contexts for the UE 401, where each RM context is associated with a specific access to the network. The RM context may be a data structure, database object, etc. that indicates or stores, inter alia, a registration state per access type and the periodic update timer. The AMF 421 may also store a 5GC MM context that may be the same or similar to the (E)MM context discussed previously. In various embodiments, the
10 AMF 421 may store a CE mode B Restriction parameter of the UE 401 in an associated MM context or RM context. The AMF 421 may also derive the value, when needed, from the UE's usage setting parameter already stored in the UE context (and/or MM/RM context).

[0077] CM may be used to establish and release a signaling connection between the UE 401 and
15 the AMF 421 over the N1 interface. The signaling connection is used to enable NAS signaling exchange between the UE 401 and the CN 420, and comprises both the signaling connection between the UE and the AN (e.g., RRC connection or UE-N3IWF connection for non-3GPP access) and the N2 connection for the UE 401 between the AN (e.g., RAN 410) and the AMF 421. The UE 401 may operate in one of two CM states, CM-IDLE mode or CM-CONNECTED
20 mode. When the UE 401 is operating in the CM-IDLE state/mode, the UE 401 may have no NAS signaling connection established with the AMF 421 over the N1 interface, and there may be (R)AN 410 signaling connection (e.g., N2 and/or N3 connections) for the UE 401. When the UE 401 is operating in the CM-CONNECTED state/mode, the UE 401 may have an established NAS signaling connection with the AMF 421 over the N1 interface, and there may be a (R)AN
25 410 signaling connection (e.g., N2 and/or N3 connections) for the UE 401. Establishment of an N2 connection between the (R)AN 410 and the AMF 421 may cause the UE 401 to transition from CM-IDLE mode to CM-CONNECTED mode, and the UE 401 may transition from the CM-CONNECTED mode to the CM-IDLE mode when N2 signaling between the (R)AN 410 and the AMF 421 is released.

30

[0078] The SMF 424 may be responsible for SM (e.g., session establishment, modify and release, including tunnel maintain between UPF and AN node); UE IP address allocation and management (including optional authorization); selection and control of UP function; configuring traffic steering at UPF to route traffic to proper destination; termination of interfaces toward policy control functions; controlling part of policy enforcement and QoS; lawful intercept (for SM events and interface to LI system); termination of SM parts of NAS messages; downlink data notification; initiating AN specific SM information, sent via AMF over N2 to AN; and determining SSC mode of a session. SM may refer to management of a PDU session, and a PDU session or “session” may refer to a PDU connectivity service that provides or enables the exchange of PDUs between a UE 401 and a data network (DN) 403 identified by a Data Network Name (DNN). PDU sessions may be established upon UE 401 request, modified upon UE 401 and 5GC 420 request, and released upon UE 401 and 5GC 420 request using NAS SM signaling exchanged over the N1 reference point between the UE 401 and the SMF 424. Upon request from an application server, the 5GC 420 may trigger a specific application in the UE 401. In response to receipt of the trigger message, the UE 401 may pass the trigger message (or relevant parts/information of the trigger message) to one or more identified applications in the UE 401. The identified application(s) in the UE 401 may establish a PDU session to a specific DNN. The SMF 424 may check whether the UE 401 requests are compliant with user subscription information associated with the UE 401. In this regard, the SMF 424 may retrieve and/or request to receive update notifications on SMF 424 level subscription data from the UDM 427.

[0079] The SMF 424 may include the following roaming functionality: handling local enforcement to apply QoS SLAs (VPLMN); charging data collection and charging interface (VPLMN); lawful intercept (in VPLMN for SM events and interface to LI system); and support for interaction with external DN for transport of signalling for PDU session authorization/authentication by external DN. An N16 reference point between two SMFs 424 may be included in the system 400, which may be between another SMF 424 in a visited network and the SMF 424 in the home network in roaming scenarios. Additionally, the SMF 424 may exhibit the Nsmf service-based interface.

30

[0080] The NEF 423 may provide means for securely exposing the services and capabilities provided by 3GPP network functions for third party, internal exposure/re-exposure, Application Functions (e.g., AF 428), edge computing or fog computing systems, etc. In such embodiments, the NEF 423 may authenticate, authorize, and/or throttle the AFs. NEF 423 may also translate information exchanged with the AF 428 and information exchanged with internal network functions. For example, the NEF 423 may translate between an AF-Service-Identifier and an internal 5GC information. NEF 423 may also receive information from other network functions (NFs) based on exposed capabilities of other network functions. This information may be stored at the NEF 423 as structured data, or at a data storage NF using standardized interfaces. The stored information can then be re-exposed by the NEF 423 to other NFs and AFs, and/or used for other purposes such as analytics. Additionally, the NEF 423 may exhibit an Nnef service-based interface.

[0081] The NRF 425 may support service discovery functions, receive NF discovery requests from NF instances, and provide the information of the discovered NF instances to the NF instances. NRF 425 also maintains information of available NF instances and their supported services. As used herein, the terms “instantiate,” “instantiation,” and the like may refer to the creation of an instance, and an “instance” may refer to a concrete occurrence of an object, which may occur, for example, during execution of program code. Additionally, the NRF 425 may exhibit the Nnrf service-based interface.

[0082] The PCF 426 may provide policy rules to control plane function(s) to enforce them, and may also support unified policy framework to govern network behaviour. The PCF 426 may also implement an FE to access subscription information relevant for policy decisions in a UDR of the UDM 427. The PCF 426 may communicate with the AMF 421 via an N15 reference point between the PCF 426 and the AMF 421, which may include a PCF 426 in a visited network and the AMF 421 in case of roaming scenarios. The PCF 426 may communicate with the AF 428 via an N5 reference point between the PCF 426 and the AF 428; and with the SMF 424 via an N7 reference point between the PCF 426 and the SMF 424. The system 400 and/or CN 420 may also include an N24 reference point between the PCF 426 (in the home network) and a PCF 426 in a visited network. Additionally, the PCF 426 may exhibit an Npcf service-based interface.

[0083] The UDM 427 may handle subscription-related information to support the network entities' handling of communication sessions, and may store subscription data of UE 401. For example, subscription data may be communicated between the UDM 427 and the AMF 421 via an N8 reference point between the UDM 427 and the AMF. The UDM 427 may include two parts, an application FE and a UDR (the FE and UDR are not shown by Figure 4). The UDR may store subscription data and policy data for the UDM 427 and the PCF 426, and/or structured data for exposure and application data (including PFDs for application detection, application request information for multiple UEs 401) for the NEF 423. The Nudr service-based interface may be exhibited by the UDR 221 to allow the UDM 427, PCF 426, and NEF 423 to access a particular set of the stored data, as well as to read, update (e.g., add, modify), delete, and subscribe to notification of relevant data changes in the UDR. The UDM may include a UDM-FE, which is in charge of processing credentials, location management, subscription management and so on. Several different front ends may serve the same user in different transactions. The UDM-FE accesses subscription information stored in the UDR and performs authentication credential processing, user identification handling, access authorization, registration/mobility management, and subscription management. The UDR may interact with the SMF 424 via an N10 reference point between the UDM 427 and the SMF 424. UDM 427 may also support SMS management, wherein an SMS-FE implements the similar application logic as discussed previously. Additionally, the UDM 427 may exhibit the Nudm service-based interface.

[0084] The AF 428 may provide application influence on traffic routing, provide access to the NCE, and interact with the policy framework for policy control. The NCE may be a mechanism that allows the 5GC 420 and AF 428 to provide information to each other via NEF 423, which may be used for edge computing implementations. In such implementations, the network operator and third party services may be hosted close to the UE 401 access point of attachment to achieve an efficient service delivery through the reduced end-to-end latency and load on the transport network. For edge computing implementations, the 5GC may select a UPF 402 close to the UE 401 and execute traffic steering from the UPF 402 to DN 403 via the N6 interface. This may be based on the UE subscription data, UE location, and information provided by the AF 428. In this way, the AF 428 may influence UPF (re)selection and traffic routing. Based on

operator deployment, when AF 428 is considered to be a trusted entity, the network operator may permit AF 428 to interact directly with relevant NFs. Additionally, the AF 428 may exhibit an Naf service-based interface.

5 [0085] The NSSF 429 may select a set of network slice instances serving the UE 401. The NSSF 429 may also determine allowed NSSAI and the mapping to the subscribed S-NSSAIs, if needed. The NSSF 429 may also determine the AMF set to be used to serve the UE 401, or a list of candidate AMF(s) 421 based on a suitable configuration and possibly by querying the NRF 425. The selection of a set of network slice instances for the UE 401 may be triggered by the AMF
10 421 with which the UE 401 is registered by interacting with the NSSF 429, which may lead to a change of AMF 421. The NSSF 429 may interact with the AMF 421 via an N22 reference point between AMF 421 and NSSF 429; and may communicate with another NSSF 429 in a visited network via an N31 reference point (not shown by Figure 4). Additionally, the NSSF 429 may exhibit an Nnssf service-based interface.

15 [0086] As discussed previously, the CN 420 may include an SMSF, which may be responsible for SMS subscription checking and verification, and relaying SM messages to/from the UE 401 to/from other entities, such as an SMS-GMSC/IWMSC/SMS-router. The SMS may also interact with AMF 421 and UDM 427 for a notification procedure that the UE 401 is available for SMS
20 transfer (e.g., set a UE not reachable flag, and notifying UDM 427 when UE 401 is available for SMS).

[0087] The CN 120 may also include other elements that are not shown by Figure 4, such as a Data Storage system/architecture, a 5G-EIR, a SEPP, and the like. The Data Storage system may
25 include a SDSF, an UDSF, and/or the like. Any NF may store and retrieve unstructured data into/from the UDSF (e.g., UE contexts), via N18 reference point between any NF and the UDSF (not shown by Figure 4). Individual NFs may share a UDSF for storing their respective unstructured data or individual NFs may each have their own UDSF located at or near the individual NFs. Additionally, the UDSF may exhibit an Nudsf service-based interface (not
30 shown by Figure 4). The 5G-EIR may be an NF that checks the status of PEI for determining whether particular equipment/entities are blacklisted from the network; and the SEPP may be a

non-transparent proxy that performs topology hiding, message filtering, and policing on inter-PLMN control plane interfaces.

[0088] Additionally, there may be many more reference points and/or service-based interfaces between the NF services in the NFs; however, these interfaces and reference points have been omitted from Figure 4 for clarity. In one example, the CN 420 may include an Nx interface, which is an inter-CN interface between the MME (e.g., MME 321) and the AMF 421 in order to enable interworking between CN 420 and CN 320. Other example interfaces/reference points may include an N5g-EIR service-based interface exhibited by a 5G-EIR, an N27 reference point between the NRF in the visited network and the NRF in the home network; and an N31 reference point between the NSSF in the visited network and the NSSF in the home network.

[0089] Figure 5 illustrates an example of infrastructure equipment 500 in accordance with various embodiments. The infrastructure equipment 500 (or “system 500”) may be implemented as a base station, radio head, RAN node such as the RAN nodes 211 and/or AP 206 shown and described previously, application server(s) 230, and/or any other element/device discussed herein. In other examples, the system 500 could be implemented in or by a UE.

[0090] The system 500 includes application circuitry 505, baseband circuitry 510, one or more radio front end modules (RFEMs) 515, memory circuitry 520, power management integrated circuitry (PMIC) 525, power tee circuitry 530, network controller circuitry 535, network interface connector 540, satellite positioning circuitry 545, and user interface 550. In some embodiments, the device 500 may include additional elements such as, for example, memory/storage, display, camera, sensor, or input/output (I/O) interface. In other embodiments, the components described below may be included in more than one device. For example, said circuitries may be separately included in more than one device for CRAN, vBBU, or other like implementations.

[0091] Application circuitry 505 includes circuitry such as, but not limited to one or more processors (or processor cores), cache memory, and one or more of low drop-out voltage regulators (LDOs), interrupt controllers, serial interfaces such as SPI, I²C or universal

programmable serial interface module, real time clock (RTC), timer-counters including interval and watchdog timers, general purpose input/output (I/O or IO), memory card controllers such as Secure Digital (SD) MultiMediaCard (MMC) or similar, Universal Serial Bus (USB) interfaces, Mobile Industry Processor Interface (MIPI) interfaces and Joint Test Access Group (JTAG) test
5 access ports. The processors (or cores) of the application circuitry 505 may be coupled with or may include memory/storage elements and may be configured to execute instructions stored in the memory/storage to enable various applications or operating systems to run on the system 500. In some implementations, the memory/storage elements may be on-chip memory circuitry, which may include any suitable volatile and/or non-volatile memory, such as DRAM, SRAM,
10 EPROM, EEPROM, Flash memory, solid-state memory, and/or any other type of memory device technology, such as those discussed herein.

[0092] The processor(s) of application circuitry 505 may include, for example, one or more processor cores (CPUs), one or more application processors, one or more graphics processing
15 units (GPUs), one or more reduced instruction set computing (RISC) processors, one or more Acorn RISC Machine (ARM) processors, one or more complex instruction set computing (CISC) processors, one or more digital signal processors (DSP), one or more FPGAs, one or more PLDs, one or more ASICs, one or more microprocessors or controllers, or any suitable combination thereof. In some embodiments, the application circuitry 505 may comprise, or may be, a special-
20 purpose processor/controller to operate according to the various embodiments herein. As examples, the processor(s) of application circuitry 505 may include one or more Intel Pentium®, Core®, or Xeon® processor(s); Advanced Micro Devices (AMD) Ryzen® processor(s), Accelerated Processing Units (APUs), or Epyc® processors; ARM-based processor(s) licensed from ARM Holdings, Ltd. such as the ARM Cortex-A family of processors and the ThunderX2®
25 provided by Cavium(TM), Inc.; a MIPS-based design from MIPS Technologies, Inc. such as MIPS Warrior P-class processors; and/or the like. In some embodiments, the system 500 may not utilize application circuitry 505, and instead may include a special-purpose processor/controller to process IP data received from an EPC or 5GC, for example.

30 **[0093]** In some implementations, the application circuitry 505 may include one or more hardware accelerators, which may be microprocessors, programmable processing devices, or the

like. The one or more hardware accelerators may include, for example, computer vision (CV) and/or deep learning (DL) accelerators. As examples, the programmable processing devices may be one or more a field-programmable devices (FPDs) such as field-programmable gate arrays (FPGAs) and the like; programmable logic devices (PLDs) such as complex PLDs (CPLDs),
5 high-capacity PLDs (HCPLDs), and the like; ASICs such as structured ASICs and the like; programmable SoCs (PSoCs); and the like. In such implementations, the circuitry of application circuitry 505 may comprise logic blocks or logic fabric, and other interconnected resources that may be programmed to perform various functions, such as the procedures, methods, functions, etc. of the various embodiments discussed herein. In such embodiments, the circuitry of
10 application circuitry 505 may include memory cells (e.g., erasable programmable read-only memory (EPROM), electrically erasable programmable read-only memory (EEPROM), flash memory, static memory (e.g., static random access memory (SRAM), anti-fuses, etc.)) used to store logic blocks, logic fabric, data, etc. in look-up-tables (LUTs) and the like.

15 **[0094]** The baseband circuitry 510 may be implemented, for example, as a solder-down substrate including one or more integrated circuits, a single packaged integrated circuit soldered to a main circuit board or a multi-chip module containing two or more integrated circuits. The various hardware electronic elements of baseband circuitry 510 are discussed infra with regard to Figure
7.

20 **[0095]** User interface circuitry 550 may include one or more user interfaces designed to enable user interaction with the system 500 or peripheral component interfaces designed to enable peripheral component interaction with the system 500. User interfaces may include, but are not
25 limited to, one or more physical or virtual buttons (e.g., a reset button), one or more indicators (e.g., light emitting diodes (LEDs)), a physical keyboard or keypad, a mouse, a touchpad, a touchscreen, speakers or other audio emitting devices, microphones, a printer, a scanner, a headset, a display screen or display device, etc. Peripheral component interfaces may include, but are not limited to, a nonvolatile memory port, a universal serial bus (USB) port, an audio
30 jack, a power supply interface, etc.

[0096] The radio front end modules (RFEMs) 515 may comprise a millimeter wave (mmWave) RFEM and one or more sub-mmWave radio frequency integrated circuits (RFICs). In some implementations, the one or more sub-mmWave RFICs may be physically separated from the mmWave RFEM. The RFICs may include connections to one or more antennas or antenna arrays (see e.g., antenna array 711 of Figure 7 infra), and the RFEM may be connected to multiple antennas. In alternative implementations, both mmWave and sub-mmWave radio functions may be implemented in the same physical RFEM 515, which incorporates both mmWave antennas and sub-mmWave.

[0097] The memory circuitry 520 may include one or more of volatile memory including dynamic random access memory (DRAM) and/or synchronous dynamic random access memory (SDRAM), and nonvolatile memory (NVM) including high-speed electrically erasable memory (commonly referred to as Flash memory), phase change random access memory (PRAM), magnetoresistive random access memory (MRAM), etc., and may incorporate the three-dimensional (3D) cross-point (XPOINT) memories from Intel® and Micron®. Memory circuitry 520 may be implemented as one or more of solder down packaged integrated circuits, socketed memory modules and plug-in memory cards.

[0098] The PMIC 525 may include voltage regulators, surge protectors, power alarm detection circuitry, and one or more backup power sources such as a battery or capacitor. The power alarm detection circuitry may detect one or more of brown out (under-voltage) and surge (over-voltage) conditions. The power tee circuitry 530 may provide for electrical power drawn from a network cable to provide both power supply and data connectivity to the infrastructure equipment 500 using a single cable.

[0099] The network controller circuitry 535 may provide connectivity to a network using a standard network interface protocol such as Ethernet, Ethernet over GRE Tunnels, Ethernet over Multiprotocol Label Switching (MPLS), or some other suitable protocol. Network connectivity may be provided to/from the infrastructure equipment 500 via network interface connector 540 using a physical connection, which may be electrical (commonly referred to as a “copper interconnect”), optical, or wireless. The network controller circuitry 535 may include one or

more dedicated processors and/or FPGAs to communicate using one or more of the aforementioned protocols. In some implementations, the network controller circuitry 535 may include multiple controllers to provide connectivity to other networks using the same or different protocols.

5

[00100] The positioning circuitry 545 includes circuitry to receive and decode signals transmitted/broadcasted by a positioning network of a global navigation satellite system (GNSS). Examples of navigation satellite constellations (or GNSS) include United States' Global Positioning System (GPS), Russia's Global Navigation System (GLONASS), the European Union's Galileo system, China's BeiDou Navigation Satellite System, a regional navigation system or GNSS augmentation system (e.g., Navigation with Indian Constellation (NAVIC), Japan's Quasi-Zenith Satellite System (QZSS), France's Doppler Orbitography and Radio-positioning Integrated by Satellite (DORIS), etc.), or the like. The positioning circuitry 545 comprises various hardware elements (e.g., including hardware devices such as switches, filters, amplifiers, antenna elements, and the like to facilitate OTA communications) to communicate with components of a positioning network, such as navigation satellite constellation nodes. In some embodiments, the positioning circuitry 545 may include a Micro-Technology for Positioning, Navigation, and Timing (Micro-PNT) IC that uses a master timing clock to perform position tracking/estimation without GNSS assistance. The positioning circuitry 545 may also be part of, or interact with, the baseband circuitry 510 and/or RFEMs 515 to communicate with the nodes and components of the positioning network. The positioning circuitry 545 may also provide position data and/or time data to the application circuitry 505, which may use the data to synchronize operations with various infrastructure (e.g., RAN nodes 211, etc.), or the like.

[00101] The components shown by Figure 5 may communicate with one another using interface circuitry, which may include any number of bus and/or interconnect (IX) technologies such as industry standard architecture (ISA), extended ISA (EISA), peripheral component interconnect (PCI), peripheral component interconnect extended (PCIx), PCI express (PCIe), or any number of other technologies. The bus/IX may be a proprietary bus, for example, used in a SoC based system. Other bus/IX systems may be included, such as an I²C interface, an SPI interface, point to point interfaces, and a power bus, among others.

30

[00102] Figure 6 illustrates an example of a platform 600 (or “device 600”) in accordance with various embodiments. In some embodiments, the computer platform 600 may be suitable for use as UEs 201, 301, 401, application servers 230, and/or any other element/device discussed
5 herein. The platform 600 may include any combinations of the components shown in the example. The components of platform 600 may be implemented as integrated circuits (ICs), portions thereof, discrete electronic devices, or other modules, logic, hardware, software, firmware, or a combination thereof adapted in the computer platform 600, or as components otherwise incorporated within a chassis of a larger system. The block diagram of Figure 6 is
10 intended to show a high level view of components of the computer platform 600. However, some of the components shown may be omitted, additional components may be present, and different arrangement of the components shown may occur in other implementations.

[00103] Application circuitry 605 includes circuitry such as, but not limited to one or more
15 processors (or processor cores), cache memory, and one or more of LDOs, interrupt controllers, serial interfaces such as SPI, I²C or universal programmable serial interface module, RTC, timer-counters including interval and watchdog timers, general purpose I/O, memory card controllers such as SD MMC or similar, USB interfaces, MIPI interfaces, and JTAG test access ports. The processors (or cores) of the application circuitry 605 may be coupled with or may include
20 memory/storage elements and may be configured to execute instructions stored in the memory/storage to enable various applications or operating systems to run on the system 600. In some implementations, the memory/storage elements may be on-chip memory circuitry, which may include any suitable volatile and/or non-volatile memory, such as DRAM, SRAM, EPROM, EEPROM, Flash memory, solid-state memory, and/or any other type of memory device
25 technology, such as those discussed herein.

[00104] The processor(s) of application circuitry 505 may include, for example, one or more processor cores, one or more application processors, one or more GPUs, one or more RISC processors, one or more ARM processors, one or more CISC processors, one or more DSP, one
30 or more FPGAs, one or more PLDs, one or more ASICs, one or more microprocessors or controllers, a multithreaded processor, an ultra-low voltage processor, an embedded processor,

some other known processing element, or any suitable combination thereof. In some embodiments, the application circuitry 505 may comprise, or may be, a special-purpose processor/controller to operate according to the various embodiments herein.

5 [00105] As examples, the processor(s) of application circuitry 605 may include an Intel® Architecture Core™ based processor, such as a Quark™, an Atom™, an i3, an i5, an i7, or an MCU-class processor, or another such processor available from Intel® Corporation, Santa Clara, CA. The processors of the application circuitry 605 may also be one or more of Advanced Micro Devices (AMD) Ryzen® processor(s) or Accelerated Processing Units (APUs); A5-A9
10 processor(s) from Apple® Inc., Snapdragon™ processor(s) from Qualcomm® Technologies, Inc., Texas Instruments, Inc.® Open Multimedia Applications Platform (OMAP)™ processor(s); a MIPS-based design from MIPS Technologies, Inc. such as MIPS Warrior M-class, Warrior I-class, and Warrior P-class processors; an ARM-based design licensed from ARM Holdings, Ltd., such as the ARM Cortex-A, Cortex-R, and Cortex-M family of processors; or the like. In some
15 implementations, the application circuitry 605 may be a part of a system on a chip (SoC) in which the application circuitry 605 and other components are formed into a single integrated circuit, or a single package, such as the Edison™ or Galileo™ SoC boards from Intel® Corporation.

20 [00106] Additionally or alternatively, application circuitry 605 may include circuitry such as, but not limited to, one or more a field-programmable devices (FPDs) such as FPGAs and the like; programmable logic devices (PLDs) such as complex PLDs (CPLDs), high-capacity PLDs (HCPLDs), and the like; ASICs such as structured ASICs and the like; programmable SoCs (PSoCs); and the like. In such embodiments, the circuitry of application circuitry 605 may
25 comprise logic blocks or logic fabric, and other interconnected resources that may be programmed to perform various functions, such as the procedures, methods, functions, etc. of the various embodiments discussed herein. In such embodiments, the circuitry of application circuitry 605 may include memory cells (e.g., erasable programmable read-only memory (EPROM), electrically erasable programmable read-only memory (EEPROM), flash memory,
30 static memory (e.g., static random access memory (SRAM), anti-fuses, etc.)) used to store logic blocks, logic fabric, data, etc. in look-up tables (LUTs) and the like.

[00107] The baseband circuitry 610 may be implemented, for example, as a solder-down substrate including one or more integrated circuits, a single packaged integrated circuit soldered to a main circuit board or a multi-chip module containing two or more integrated circuits. The various hardware electronic elements of baseband circuitry 610 are discussed infra with regard to Figure 7.

[00108] The RFEMs 615 may comprise a millimeter wave (mmWave) RFEM and one or more sub-mmWave radio frequency integrated circuits (RFICs). In some implementations, the one or more sub-mmWave RFICs may be physically separated from the mmWave RFEM. The RFICs may include connections to one or more antennas or antenna arrays (see e.g., antenna array 711 of Figure 7 infra), and the RFEM may be connected to multiple antennas. In alternative implementations, both mmWave and sub-mmWave radio functions may be implemented in the same physical RFEM 615, which incorporates both mmWave antennas and sub-mmWave.

[00109] The memory circuitry 620 may include any number and type of memory devices used to provide for a given amount of system memory. As examples, the memory circuitry 620 may include one or more of volatile memory including random access memory (RAM), dynamic RAM (DRAM) and/or synchronous dynamic RAM (SDRAM), and nonvolatile memory (NVM) including high-speed electrically erasable memory (commonly referred to as Flash memory), phase change random access memory (PRAM), magnetoresistive random access memory (MRAM), etc. The memory circuitry 620 may be developed in accordance with a Joint Electron Devices Engineering Council (JEDEC) low power double data rate (LPDDR)-based design, such as LPDDR2, LPDDR3, LPDDR4, or the like. Memory circuitry 620 may be implemented as one or more of solder down packaged integrated circuits, single die package (SDP), dual die package (DDP) or quad die package (Q17P), socketed memory modules, dual inline memory modules (DIMMs) including microDIMMs or MiniDIMMs, and/or soldered onto a motherboard via a ball grid array (BGA). In low power implementations, the memory circuitry 620 may be on-die memory or registers associated with the application circuitry 605. To provide for persistent storage of information such as data, applications, operating systems and so forth, memory circuitry 620 may include one or more mass storage devices, which may include, inter alia, a

solid state disk drive (SSDD), hard disk drive (HDD), a micro HDD, resistance change memories, phase change memories, holographic memories, or chemical memories, among others. For example, the computer platform 600 may incorporate the three-dimensional (3D) cross-point (XPOINT) memories from Intel® and Micron®.

5

[00110] Removable memory circuitry 623 may include devices, circuitry, enclosures/housings, ports or receptacles, etc. used to couple portable data storage devices with the platform 600. These portable data storage devices may be used for mass storage purposes, and may include, for example, flash memory cards (e.g., Secure Digital (SD) cards, microSD cards, xD picture cards, and the like), and USB flash drives, optical discs, external HDDs, and the like.

10

[00111] The platform 600 may also include interface circuitry (not shown) that is used to connect external devices with the platform 600. The external devices connected to the platform 600 via the interface circuitry include sensor circuitry 621 and electro-mechanical components (EMCs) 622, as well as removable memory devices coupled to removable memory circuitry 623.

15

[00112] The sensor circuitry 621 include devices, modules, or subsystems whose purpose is to detect events or changes in its environment and send the information (sensor data) about the detected events to some other a device, module, subsystem, etc. Examples of such sensors include, inter alia, inertia measurement units (IMUs) comprising accelerometers, gyroscopes, and/or magnetometers; microelectromechanical systems (MEMS) or nanoelectromechanical systems (NEMS) comprising 3-axis accelerometers, 3-axis gyroscopes, and/or magnetometers; level sensors; flow sensors; temperature sensors (e.g., thermistors); pressure sensors; barometric pressure sensors; gravimeters; altimeters; image capture devices (e.g., cameras or lensless apertures); light detection and ranging (LiDAR) sensors; proximity sensors (e.g., infrared radiation detector and the like), depth sensors, ambient light sensors, ultrasonic transceivers; microphones or other like audio capture devices; etc.

20

25

[00113] EMCs 622 include devices, modules, or subsystems whose purpose is to enable platform 600 to change its state, position, and/or orientation, or move or control a mechanism or

30

(sub)system. Additionally, EMCs 622 may be configured to generate and send messages/signalling to other components of the platform 600 to indicate a current state of the EMCs 622. Examples of the EMCs 622 include one or more power switches, relays including electromechanical relays (EMRs) and/or solid state relays (SSRs), actuators (e.g., valve actuators, etc.), an audible sound generator, a visual warning device, motors (e.g., DC motors, stepper motors, etc.), wheels, thrusters, propellers, claws, clamps, hooks, and/or other like electro-mechanical components. In some embodiments, platform 600 is configured to operate one or more EMCs 622 based on one or more captured events and/or instructions or control signals received from a service provider and/or various clients.

10

[00114] In some implementations, the interface circuitry may connect the platform 600 with positioning circuitry 645. The positioning circuitry 645 includes circuitry to receive and decode signals transmitted/broadcasted by a positioning network of a GNSS. Examples of navigation satellite constellations (or GNSS) include United States' GPS, Russia's GLONASS, the European Union's Galileo system, China's BeiDou Navigation Satellite System, a regional navigation system or GNSS augmentation system (e.g., NAVIC), Japan's QZSS, France's DORIS, etc.), or the like. The positioning circuitry 645 comprises various hardware elements (e.g., including hardware devices such as switches, filters, amplifiers, antenna elements, and the like to facilitate OTA communications) to communicate with components of a positioning network, such as navigation satellite constellation nodes. In some embodiments, the positioning circuitry 645 may include a Micro-PNT IC that uses a master timing clock to perform position tracking/estimation without GNSS assistance. The positioning circuitry 645 may also be part of, or interact with, the baseband circuitry 510 and/or RFEMs 615 to communicate with the nodes and components of the positioning network. The positioning circuitry 645 may also provide position data and/or time data to the application circuitry 605, which may use the data to synchronize operations with various infrastructure (e.g., radio base stations), for turn-by-turn navigation applications, or the like.

15

20

25

30

[00115] In some implementations, the interface circuitry may connect the platform 600 with Near-Field Communication (NFC) circuitry 640. NFC circuitry 640 is configured to provide contactless, short-range communications based on radio frequency identification (RFID)

standards, wherein magnetic field induction is used to enable communication between NFC circuitry 640 and NFC-enabled devices external to the platform 600 (e.g., an “NFC touchpoint”). NFC circuitry 640 comprises an NFC controller coupled with an antenna element and a processor coupled with the NFC controller. The NFC controller may be a chip/IC providing NFC functionalities to the NFC circuitry 640 by executing NFC controller firmware and an NFC stack. The NFC stack may be executed by the processor to control the NFC controller, and the NFC controller firmware may be executed by the NFC controller to control the antenna element to emit short-range RF signals. The RF signals may power a passive NFC tag (e.g., a microchip embedded in a sticker or wristband) to transmit stored data to the NFC circuitry 640, or initiate data transfer between the NFC circuitry 640 and another active NFC device (e.g., a smartphone or an NFC-enabled POS terminal) that is proximate to the platform 600.

[00116] The driver circuitry 646 may include software and hardware elements that operate to control particular devices that are embedded in the platform 600, attached to the platform 600, or otherwise communicatively coupled with the platform 600. The driver circuitry 646 may include individual drivers allowing other components of the platform 600 to interact with or control various input/output (I/O) devices that may be present within, or connected to, the platform 600. For example, driver circuitry 646 may include a display driver to control and allow access to a display device, a touchscreen driver to control and allow access to a touchscreen interface of the platform 600, sensor drivers to obtain sensor readings of sensor circuitry 621 and control and allow access to sensor circuitry 621, EMC drivers to obtain actuator positions of the EMCs 622 and/or control and allow access to the EMCs 622, a camera driver to control and allow access to an embedded image capture device, audio drivers to control and allow access to one or more audio devices.

[00117] The power management integrated circuitry (PMIC) 625 (also referred to as “power management circuitry 625”) may manage power provided to various components of the platform 600. In particular, with respect to the baseband circuitry 610, the PMIC 625 may control power-source selection, voltage scaling, battery charging, or DC-to-DC conversion. The PMIC 625 may often be included when the platform 600 is capable of being powered by a battery 630, for example, when the device is included in a UE 201, 301, 401.

[00118] In some embodiments, the PMIC 625 may control, or otherwise be part of, various power saving mechanisms of the platform 600. For example, if the platform 600 is in an RRC_Connected state, where it is still connected to the RAN node as it expects to receive traffic shortly, then it may enter a state known as Discontinuous Reception Mode (DRX) after a period of inactivity. During this state, the platform 600 may power down for brief intervals of time and thus save power. If there is no data traffic activity for an extended period of time, then the platform 600 may transition off to an RRC_Idle state, where it disconnects from the network and does not perform operations such as channel quality feedback, handover, etc. The platform 600 goes into a very low power state and it performs paging where again it periodically wakes up to listen to the network and then powers down again. The platform 600 may not receive data in this state; in order to receive data, it must transition back to RRC_Connected state. An additional power saving mode may allow a device to be unavailable to the network for periods longer than a paging interval (ranging from seconds to a few hours). During this time, the device is totally unreachable to the network and may power down completely. Any data sent during this time incurs a large delay and it is assumed the delay is acceptable.

[00119] A battery 630 may power the platform 600, although in some examples the platform 600 may be mounted deployed in a fixed location, and may have a power supply coupled to an electrical grid. The battery 630 may be a lithium ion battery, a metal-air battery, such as a zinc-air battery, an aluminum-air battery, a lithium-air battery, and the like. In some implementations, such as in V2X applications, the battery 630 may be a typical lead-acid automotive battery.

[00120] In some implementations, the battery 630 may be a “smart battery,” which includes or is coupled with a Battery Management System (BMS) or battery monitoring integrated circuitry. The BMS may be included in the platform 600 to track the state of charge (SoCh) of the battery 630. The BMS may be used to monitor other parameters of the battery 630 to provide failure predictions, such as the state of health (SoH) and the state of function (SoF) of the battery 630. The BMS may communicate the information of the battery 630 to the application circuitry 605 or other components of the platform 600. The BMS may also include an analog-to-

digital (ADC) convertor that allows the application circuitry 605 to directly monitor the voltage of the battery 630 or the current flow from the battery 630. The battery parameters may be used to determine actions that the platform 600 may perform, such as transmission frequency, network operation, sensing frequency, and the like.

5

[00121] A power block, or other power supply coupled to an electrical grid may be coupled with the BMS to charge the battery 630. In some examples, the power block XS30 may be replaced with a wireless power receiver to obtain the power wirelessly, for example, through a loop antenna in the computer platform 600. In these examples, a wireless battery charging circuit may be included in the BMS. The specific charging circuits chosen may depend on the size of the battery 630, and thus, the current required. The charging may be performed using the Airfuel standard promulgated by the Airfuel Alliance, the Qi wireless charging standard promulgated by the Wireless Power Consortium, or the Rezence charging standard promulgated by the Alliance for Wireless Power, among others.

15

[00122] User interface circuitry 650 includes various input/output (I/O) devices present within, or connected to, the platform 600, and includes one or more user interfaces designed to enable user interaction with the platform 600 and/or peripheral component interfaces designed to enable peripheral component interaction with the platform 600. The user interface circuitry 650 includes input device circuitry and output device circuitry. Input device circuitry includes any physical or virtual means for accepting an input including, inter alia, one or more physical or virtual buttons (e.g., a reset button), a physical keyboard, keypad, mouse, touchpad, touchscreen, microphones, scanner, headset, and/or the like. The output device circuitry includes any physical or virtual means for showing information or otherwise conveying information, such as sensor readings, actuator position(s), or other like information. Output device circuitry may include any number and/or combinations of audio or visual display, including, inter alia, one or more simple visual outputs/indicators (e.g., binary status indicators (e.g., light emitting diodes (LEDs)) and multi-character visual outputs, or more complex outputs such as display devices or touchscreens (e.g., Liquid Chrystal Displays (LCD), LED displays, quantum dot displays, projectors, etc.), with the output of characters, graphics, multimedia objects, and the like being generated or produced from the operation of the platform 600. The output device circuitry may also include

25
30

speakers or other audio emitting devices, printer(s), and/or the like. In some embodiments, the sensor circuitry 621 may be used as the input device circuitry (e.g., an image capture device, motion capture device, or the like) and one or more EMCs may be used as the output device circuitry (e.g., an actuator to provide haptic feedback or the like). In another example, NFC circuitry comprising an NFC controller coupled with an antenna element and a processing device
5 may be included to read electronic tags and/or connect with another NFC-enabled device. Peripheral component interfaces may include, but are not limited to, a non-volatile memory port, a USB port, an audio jack, a power supply interface, etc.

10 **[00123]** Although not shown, the components of platform 600 may communicate with one another using a suitable bus or interconnect (IX) technology, which may include any number of technologies, including ISA, EISA, PCI, PCIx, PCIe, a Time-Trigger Protocol (TTP) system, a FlexRay system, or any number of other technologies. The bus/IX may be a proprietary bus/IX, for example, used in a SoC based system. Other bus/IX systems may be included, such as an I²C
15 interface, an SPI interface, point-to-point interfaces, and a power bus, among others.

[00124] Figure 7 illustrates example components of baseband circuitry 710 and radio front end modules (RFEM) 715 in accordance with various embodiments. The baseband circuitry 710 corresponds to the baseband circuitry 510 and 610 of Figures 5 and 6, respectively. The RFEM
20 715 corresponds to the RFEM 515 and 615 of Figures 5 and 6, respectively. As shown, the RFEMs 715 may include Radio Frequency (RF) circuitry 706, front-end module (FEM) circuitry 708, antenna array 711 coupled together at least as shown.

[00125] The baseband circuitry 710 includes circuitry and/or control logic configured to
25 carry out various radio/network protocol and radio control functions that enable communication with one or more radio networks via the RF circuitry 706. The radio control functions may include, but are not limited to, signal modulation/demodulation, encoding/decoding, radio frequency shifting, etc. In some embodiments, modulation/demodulation circuitry of the baseband circuitry 710 may include Fast-Fourier Transform (FFT), precoding, or constellation
30 mapping/demapping functionality. In some embodiments, encoding/decoding circuitry of the baseband circuitry 710 may include convolution, tail-biting convolution, turbo, Viterbi, or Low

Density Parity Check (LDPC) encoder/decoder functionality. Embodiments of modulation/demodulation and encoder/decoder functionality are not limited to these examples and may include other suitable functionality in other embodiments. The baseband circuitry 710 is configured to process baseband signals received from a receive signal path of the RF circuitry 706 and to generate baseband signals for a transmit signal path of the RF circuitry 706. The baseband circuitry 710 is configured to interface with application circuitry 505/605 (see Figures 5 and 6) for generation and processing of the baseband signals and for controlling operations of the RF circuitry 706. The baseband circuitry 710 may handle various radio control functions.

10 [00126] The aforementioned circuitry and/or control logic of the baseband circuitry 710 may include one or more single or multi-core processors. For example, the one or more processors may include a 3G baseband processor 704A, a 4G/LTE baseband processor 704B, a 5G/NR baseband processor 704C, or some other baseband processor(s) 704D for other existing generations, generations in development or to be developed in the future (e.g., sixth generation 15 (6G), etc.). In other embodiments, some or all of the functionality of baseband processors 704A-D may be included in modules stored in the memory 704G and executed via a Central Processing Unit (CPU) 704E. In other embodiments, some or all of the functionality of baseband processors 704A-D may be provided as hardware accelerators (e.g., FPGAs, ASICs, etc.) loaded with the appropriate bit streams or logic blocks stored in respective memory cells. In various 20 embodiments, the memory 704G may store program code of a real-time OS (RTOS), which when executed by the CPU 704E (or other baseband processor), is to cause the CPU 704E (or other baseband processor) to manage resources of the baseband circuitry 710, schedule tasks, etc. Examples of the RTOS may include Operating System Embedded (OSE)[™] provided by Enea®, Nucleus RTOS[™] provided by Mentor Graphics®, Versatile Real-Time Executive (VRTX) 25 provided by Mentor Graphics®, ThreadX[™] provided by Express Logic®, FreeRTOS, REX OS provided by Qualcomm®, OKL4 provided by Open Kernel (OK) Labs®, or any other suitable RTOS, such as those discussed herein. In addition, the baseband circuitry 710 includes one or more audio digital signal processor(s) (DSP) 704F. The audio DSP(s) 704F include elements for compression/decompression and echo cancellation and may include other suitable processing 30 elements in other embodiments.

[00127] In some embodiments, each of the processors 704A-704D include respective memory interfaces to send/receive data to/from the memory 704G. The baseband circuitry 710 may further include one or more interfaces to communicatively couple to other circuitries/devices, such as an interface to send/receive data to/from memory external to the baseband circuitry 710; an application circuitry interface to send/receive data to/from the application circuitry 505/605 of FIGS. 5-7); an RF circuitry interface to send/receive data to/from RF circuitry 706 of Figure 7; a wireless hardware connectivity interface to send/receive data to/from one or more wireless hardware elements (e.g., Near Field Communication (NFC) components, Bluetooth®/ Bluetooth® Low Energy components, Wi-Fi® components, and/or the like); and a power management interface to send/receive power or control signals to/from the PMIC 625.

[00128] In alternate embodiments (which may be combined with the above described embodiments), baseband circuitry 710 comprises one or more digital baseband systems, which are coupled with one another via an interconnect subsystem and to a CPU subsystem, an audio subsystem, and an interface subsystem. The digital baseband subsystems may also be coupled to a digital baseband interface and a mixed-signal baseband subsystem via another interconnect subsystem. Each of the interconnect subsystems may include a bus system, point-to-point connections, network-on-chip (NOC) structures, and/or some other suitable bus or interconnect technology, such as those discussed herein. The audio subsystem may include DSP circuitry, buffer memory, program memory, speech processing accelerator circuitry, data converter circuitry such as analog-to-digital and digital-to-analog converter circuitry, analog circuitry including one or more of amplifiers and filters, and/or other like components. In an aspect of the present disclosure, baseband circuitry 710 may include protocol processing circuitry with one or more instances of control circuitry (not shown) to provide control functions for the digital baseband circuitry and/or radio frequency circuitry (e.g., the radio front end modules 715).

[00129] Although not shown by Figure 7, in some embodiments, the baseband circuitry 710 includes individual processing device(s) to operate one or more wireless communication protocols (e.g., a “multi-protocol baseband processor” or “protocol processing circuitry”) and individual processing device(s) to implement PHY layer functions. In these embodiments, the

PHY layer functions include the aforementioned radio control functions. In these embodiments, the protocol processing circuitry operates or implements various protocol layers/entities of one or more wireless communication protocols. In a first example, the protocol processing circuitry may operate LTE protocol entities and/or 5G/NR protocol entities when the baseband circuitry 710 and/or RF circuitry 706 are part of mmWave communication circuitry or some other suitable cellular communication circuitry. In the first example, the protocol processing circuitry would operate MAC, RLC, PDCP, SDAP, RRC, and NAS functions. In a second example, the protocol processing circuitry may operate one or more IEEE-based protocols when the baseband circuitry 710 and/or RF circuitry 706 are part of a Wi-Fi communication system. In the second example, the protocol processing circuitry would operate Wi-Fi MAC and logical link control (LLC) functions. The protocol processing circuitry may include one or more memory structures (e.g., 704G) to store program code and data for operating the protocol functions, as well as one or more processing cores to execute the program code and perform various operations using the data. The baseband circuitry 710 may also support radio communications for more than one wireless protocol.

[00130] The various hardware elements of the baseband circuitry 710 discussed herein may be implemented, for example, as a solder-down substrate including one or more integrated circuits (ICs), a single packaged IC soldered to a main circuit board or a multi-chip module containing two or more ICs. In one example, the components of the baseband circuitry 710 may be suitably combined in a single chip or chipset, or disposed on a same circuit board. In another example, some or all of the constituent components of the baseband circuitry 710 and RF circuitry 706 may be implemented together such as, for example, a system on a chip (SoC) or System-in-Package (SiP). In another example, some or all of the constituent components of the baseband circuitry 710 may be implemented as a separate SoC that is communicatively coupled with and RF circuitry 706 (or multiple instances of RF circuitry 706). In yet another example, some or all of the constituent components of the baseband circuitry 710 and the application circuitry 505/605 may be implemented together as individual SoCs mounted to a same circuit board (e.g., a “multi-chip package”).

30

[00131] In some embodiments, the baseband circuitry 710 may provide for communication compatible with one or more radio technologies. For example, in some embodiments, the baseband circuitry 710 may support communication with an E-UTRAN or other WMAN, a WLAN, a WPAN. Embodiments in which the baseband circuitry 710 is
5 configured to support radio communications of more than one wireless protocol may be referred to as multi-mode baseband circuitry.

[00132] RF circuitry 706 may enable communication with wireless networks using
10 modulated electromagnetic radiation through a non-solid medium. In various embodiments, the RF circuitry 706 may include switches, filters, amplifiers, etc. to facilitate the communication with the wireless network. RF circuitry 706 may include a receive signal path, which may include circuitry to down-convert RF signals received from the FEM circuitry 708 and provide baseband signals to the baseband circuitry 710. RF circuitry 706 may also include a transmit
15 signal path, which may include circuitry to up-convert baseband signals provided by the baseband circuitry 710 and provide RF output signals to the FEM circuitry 708 for transmission.

[00133] In some embodiments, the receive signal path of the RF circuitry 706 may include mixer circuitry 706a, amplifier circuitry 706b and filter circuitry 706c. In some embodiments, the
20 transmit signal path of the RF circuitry 706 may include filter circuitry 706c and mixer circuitry 706a. RF circuitry 706 may also include synthesizer circuitry 706d for synthesizing a frequency for use by the mixer circuitry 706a of the receive signal path and the transmit signal path. In some embodiments, the mixer circuitry 706a of the receive signal path may be configured to down-convert RF signals received from the FEM circuitry 708 based on the synthesized
25 frequency provided by synthesizer circuitry 706d. The amplifier circuitry 706b may be configured to amplify the down-converted signals and the filter circuitry 706c may be a low-pass filter (LPF) or band-pass filter (BPF) configured to remove unwanted signals from the down-converted signals to generate output baseband signals. Output baseband signals may be provided to the baseband circuitry 710 for further processing. In some embodiments, the output baseband
30 signals may be zero-frequency baseband signals, although this is not a requirement. In some

embodiments, mixer circuitry 706a of the receive signal path may comprise passive mixers, although the scope of the embodiments is not limited in this respect.

[00134] In some embodiments, the mixer circuitry 706a of the transmit signal path may be configured to up-convert input baseband signals based on the synthesized frequency provided by the synthesizer circuitry 706d to generate RF output signals for the FEM circuitry 708. The baseband signals may be provided by the baseband circuitry 710 and may be filtered by filter circuitry 706c.

[00135] In some embodiments, the mixer circuitry 706a of the receive signal path and the mixer circuitry 706a of the transmit signal path may include two or more mixers and may be arranged for quadrature downconversion and upconversion, respectively. In some embodiments, the mixer circuitry 706a of the receive signal path and the mixer circuitry 706a of the transmit signal path may include two or more mixers and may be arranged for image rejection (e.g., Hartley image rejection). In some embodiments, the mixer circuitry 706a of the receive signal path and the mixer circuitry 706a of the transmit signal path may be arranged for direct downconversion and direct upconversion, respectively. In some embodiments, the mixer circuitry 706a of the receive signal path and the mixer circuitry 706a of the transmit signal path may be configured for super-heterodyne operation.

[00136] In some embodiments, the output baseband signals and the input baseband signals may be analog baseband signals, although the scope of the embodiments is not limited in this respect. In some alternate embodiments, the output baseband signals and the input baseband signals may be digital baseband signals. In these alternate embodiments, the RF circuitry 706 may include analog-to-digital converter (ADC) and digital-to-analog converter (DAC) circuitry and the baseband circuitry 710 may include a digital baseband interface to communicate with the RF circuitry 706.

[00137] In some dual-mode embodiments, a separate radio IC circuitry may be provided for processing signals for each spectrum, although the scope of the embodiments is not limited in this respect.

[00138] In some embodiments, the synthesizer circuitry 706d may be a fractional-N synthesizer or a fractional $N/N+1$ synthesizer, although the scope of the embodiments is not limited in this respect as other types of frequency synthesizers may be suitable. For example, synthesizer circuitry 706d may be a delta-sigma synthesizer, a frequency multiplier, or a synthesizer comprising a phase-locked loop with a frequency divider.

[00139] The synthesizer circuitry 706d may be configured to synthesize an output frequency for use by the mixer circuitry 706a of the RF circuitry 706 based on a frequency input and a divider control input. In some embodiments, the synthesizer circuitry 706d may be a fractional $N/N+1$ synthesizer.

[00140] In some embodiments, frequency input may be provided by a voltage controlled oscillator (VCO), although that is not a requirement. Divider control input may be provided by either the baseband circuitry 710 or the application circuitry 505/605 depending on the desired output frequency. In some embodiments, a divider control input (e.g., N) may be determined from a look-up table based on a channel indicated by the application circuitry 505/605.

[00141] Synthesizer circuitry 706d of the RF circuitry 706 may include a divider, a delay-locked loop (DLL), a multiplexer and a phase accumulator. In some embodiments, the divider may be a dual modulus divider (DMD) and the phase accumulator may be a digital phase accumulator (DPA). In some embodiments, the DMD may be configured to divide the input signal by either N or $N+1$ (e.g., based on a carry out) to provide a fractional division ratio. In some example embodiments, the DLL may include a set of cascaded, tunable, delay elements, a phase detector, a charge pump and a D-type flip-flop. In these embodiments, the delay elements may be configured to break a VCO period up into N_d equal packets of phase, where N_d is the number of delay elements in the delay line. In this way, the DLL provides negative feedback to help ensure that the total delay through the delay line is one VCO cycle.

[00142] In some embodiments, synthesizer circuitry 706d may be configured to generate a carrier frequency as the output frequency, while in other embodiments, the output frequency may

be a multiple of the carrier frequency (e.g., twice the carrier frequency, four times the carrier frequency) and used in conjunction with quadrature generator and divider circuitry to generate multiple signals at the carrier frequency with multiple different phases with respect to each other. In some embodiments, the output frequency may be a LO frequency (f_{LO}). In some
5 embodiments, the RF circuitry 706 may include an IQ/polar converter.

[00143] FEM circuitry 708 may include a receive signal path, which may include circuitry configured to operate on RF signals received from antenna array 711, amplify the received signals and provide the amplified versions of the received signals to the RF circuitry 706 for
10 further processing. FEM circuitry 708 may also include a transmit signal path, which may include circuitry configured to amplify signals for transmission provided by the RF circuitry 706 for transmission by one or more of antenna elements of antenna array 711. In various embodiments, the amplification through the transmit or receive signal paths may be done solely in the RF circuitry 706, solely in the FEM circuitry 708, or in both the RF circuitry 706 and the
15 FEM circuitry 708.

[00144] In some embodiments, the FEM circuitry 708 may include a TX/RX switch to switch between transmit mode and receive mode operation. The FEM circuitry 708 may include a receive signal path and a transmit signal path. The receive signal path of the FEM circuitry 708
20 may include an LNA to amplify received RF signals and provide the amplified received RF signals as an output (e.g., to the RF circuitry 706). The transmit signal path of the FEM circuitry 708 may include a power amplifier (PA) to amplify input RF signals (e.g., provided by RF circuitry 706), and one or more filters to generate RF signals for subsequent transmission by one or more antenna elements of the antenna array 711.

25
[00145] The antenna array 711 comprises one or more antenna elements, each of which is configured convert electrical signals into radio waves to travel through the air and to convert received radio waves into electrical signals. For example, digital baseband signals provided by the baseband circuitry 710 is converted into analog RF signals (e.g., modulated waveform) that
30 will be amplified and transmitted via the antenna elements of the antenna array 711 including one or more antenna elements (not shown). The antenna elements may be omnidirectional,

direction, or a combination thereof. The antenna elements may be formed in a multitude of
arranges as are known and/or discussed herein. The antenna array 711 may comprise microstrip
antennas or printed antennas that are fabricated on the surface of one or more printed circuit
boards. The antenna array 711 may be formed in as a patch of metal foil (e.g., a patch antenna) in
5 a variety of shapes, and may be coupled with the RF circuitry 706 and/or FEM circuitry 708
using metal transmission lines or the like.

[00146] Processors of the application circuitry 505/605 and processors of the baseband
circuitry 710 may be used to execute elements of one or more instances of a protocol stack. For
10 example, processors of the baseband circuitry 710, alone or in combination, may be used execute
Layer 3, Layer 2, or Layer 1 functionality, while processors of the application circuitry 505/605
may utilize data (e.g., packet data) received from these layers and further execute Layer 4
functionality (e.g., TCP and UDP layers). As referred to herein, Layer 3 may comprise a RRC
layer, described in further detail below. As referred to herein, Layer 2 may comprise a MAC
15 layer, an RLC layer, and a PDCP layer, described in further detail below. As referred to herein,
Layer 1 may comprise a PHY layer of a UE/RAN node, described in further detail below.

[00147] Figure 8 illustrates components of a core network (e.g., CN 320) in accordance
with various embodiments. The components of the CN 320 may be implemented in one physical
20 node or separate physical nodes including components to read and execute instructions from a
machine-readable or computer-readable medium (e.g., a non-transitory machine-readable storage
medium). In some embodiments, the components of CN 420 may be implemented in a same or
similar manner as discussed herein with regard to the components of CN 320. In some
embodiments, NFV is utilized to virtualize any or all of the above-described network node
25 functions via executable instructions stored in one or more computer-readable storage mediums
(described in further detail below). A logical instantiation of the CN 320 may be referred to as a
network slice 801, and individual logical instantiations of the CN 320 may provide specific
network capabilities and network characteristics. A logical instantiation of a portion of the CN
320 may be referred to as a network sub-slice 802 (e.g., the network sub-slice 802 is shown to
30 include the P-GW 323 and the PCRF 326).

[00148] As used herein, the terms “instantiate,” “instantiation,” and the like may refer to the creation of an instance, and an “instance” may refer to a concrete occurrence of an object, which may occur, for example, during execution of program code. A network instance may refer to information identifying a domain, which may be used for traffic detection and routing in case of different IP domains or overlapping IP addresses. A network slice instance may refer to a set of network functions (NFs) instances and the resources (e.g., compute, storage, and networking resources) required to deploy the network slice.

[00149] With respect to 5G systems (see, e.g., Figure 4), a network slice comprises a RAN part and a CN part. The support of network slicing relies on the principle that traffic for different slices is handled by different PDU sessions. The network can realize the different network slices by scheduling and also by providing different L1/L2 configurations. The UE 401 provides assistance information for network slice selection in an appropriate RRC message, if it has been provided by NAS. While the network can support large number of slices, the UE need not support more than 8 slices simultaneously.

[00150] A network slice may include the CN 420 control plane and user plane NFs, NG-RANs 410 in a serving PLMN, and a N3IWF functions in the serving PLMN. Individual network slices may have different S-NSSAI and/or may have different SSTs. NSSAI includes one or more S-NSSAIs, and each network slice is uniquely identified by an S-NSSAI. Network slices may differ for supported features and network functions optimizations, and/or multiple network slice instances may deliver the same service/features but for different groups of UEs 401 (e.g., enterprise users). For example, individual network slices may deliver different committed service(s) and/or may be dedicated to a particular customer or enterprise. In this example, each network slice may have different S-NSSAIs with the same SST but with different slice differentiators. Additionally, a single UE may be served with one or more network slice instances simultaneously via a 5G AN and associated with eight different S-NSSAIs. Moreover, an AMF 421 instance serving an individual UE 401 may belong to each of the network slice instances serving that UE.

30

[00151] Network Slicing in the NG-RAN 410 involves RAN slice awareness. RAN slice awareness includes differentiated handling of traffic for different network slices, which have been pre-configured. Slice awareness in the NG-RAN 410 is introduced at the PDU session level by indicating the S-NSSAI corresponding to a PDU session in all signaling that includes PDU session resource information. How the NG-RAN 410 supports the slice enabling in terms of NG-RAN functions (e.g., the set of network functions that comprise each slice) is implementation dependent. The NG-RAN 410 selects the RAN part of the network slice using assistance information provided by the UE 401 or the 5GC 420, which unambiguously identifies one or more of the pre-configured network slices in the PLMN. The NG-RAN 410 also supports resource management and policy enforcement between slices as per SLAs. A single NG-RAN node may support multiple slices, and the NG-RAN 410 may also apply an appropriate RRM policy for the SLA in place to each supported slice. The NG-RAN 410 may also support QoS differentiation within a slice.

15 [00152] The NG-RAN 410 may also use the UE assistance information for the selection of an AMF 421 during an initial attach, if available. The NG-RAN 410 uses the assistance information for routing the initial NAS to an AMF 421. If the NG-RAN 410 is unable to select an AMF 421 using the assistance information, or the UE 401 does not provide any such information, the NG-RAN 410 sends the NAS signaling to a default AMF 421, which may be among a pool of AMFs 421. For subsequent accesses, the UE 401 provides a temp ID, which is assigned to the UE 401 by the 5GC 420, to enable the NG-RAN 410 to route the NAS message to the appropriate AMF 421 as long as the temp ID is valid. The NG-RAN 410 is aware of, and can reach, the AMF 421 that is associated with the temp ID. Otherwise, the method for initial attach applies.

25 [00153] The NG-RAN 410 supports resource isolation between slices. NG-RAN 410 resource isolation may be achieved by means of RRM policies and protection mechanisms that should avoid that shortage of shared resources if one slice breaks the service level agreement for another slice. In some implementations, it is possible to fully dedicate NG-RAN 410 resources to a certain slice. How NG-RAN 410 supports resource isolation is implementation dependent.

30

[00154] Some slices may be available only in part of the network. Awareness in the NG-RAN 410 of the slices supported in the cells of its neighbors may be beneficial for inter-frequency mobility in connected mode. The slice availability may not change within the UE's registration area. The NG-RAN 410 and the 5GC 420 are responsible to handle a service request
5 for a slice that may or may not be available in a given area. Admission or rejection of access to a slice may depend on factors such as support for the slice, availability of resources, support of the requested service by NG-RAN 410.

[00155] The UE 401 may be associated with multiple network slices simultaneously. In
10 case the UE 401 is associated with multiple slices simultaneously, only one signaling connection is maintained, and for intra-frequency cell reselection, the UE 401 tries to camp on the best cell. For inter-frequency cell reselection, dedicated priorities can be used to control the frequency on which the UE 401 camps. The 5GC 420 is to validate that the UE 401 has the rights to access a network slice. Prior to receiving an Initial Context Setup Request message, the NG-RAN 410
15 may be allowed to apply some provisional/local policies, based on awareness of a particular slice that the UE 401 is requesting to access. During the initial context setup, the NG-RAN 410 is informed of the slice for which resources are being requested.

[00156] NFV architectures and infrastructures may be used to virtualize one or more NFs,
20 alternatively performed by proprietary hardware, onto physical resources comprising a combination of industry-standard server hardware, storage hardware, or switches. In other words, NFV systems can be used to execute virtual or reconfigurable implementations of one or more EPC components/functions.

[00157] Figure 9 is a block diagram illustrating components, according to some example
25 embodiments, of a system 900 to support NFV. The system 900 is illustrated as including a VIM 902, an NFVI 904, an VNFM 906, VNFs 908, an EM 910, an NFVO 912, and a NM 914.

[00158] The VIM 902 manages the resources of the NFVI 904. The NFVI 904 can include
30 physical or virtual resources and applications (including hypervisors) used to execute the system 900. The VIM 902 may manage the life cycle of virtual resources with the NFVI 904 (e.g.,

creation, maintenance, and tear down of VMs associated with one or more physical resources), track VM instances, track performance, fault and security of VM instances and associated physical resources, and expose VM instances and associated physical resources to other management systems.

5

[00159] The VNFM 906 may manage the VNFs 908. The VNFs 908 may be used to execute EPC components/functions. The VNFM 906 may manage the life cycle of the VNFs 908 and track performance, fault and security of the virtual aspects of VNFs 908. The EM 910 may track the performance, fault and security of the functional aspects of VNFs 908. The tracking data from the VNFM 906 and the EM 910 may comprise, for example, PM data used by the VIM 902 or the NFVI 904. Both the VNFM 906 and the EM 910 can scale up/down the quantity of VNFs of the system 900.

10

[00160] The NFVO 912 may coordinate, authorize, release and engage resources of the NFVI 904 in order to provide the requested service (e.g., to execute an EPC function, component, or slice). The NM 914 may provide a package of end-user functions with the responsibility for the management of a network, which may include network elements with VNFs, non-virtualized network functions, or both (management of the VNFs may occur via the EM 910).

20

[00161] Figure 10 is a block diagram illustrating components, according to some example embodiments, able to read instructions from a machine-readable or computer-readable medium (e.g., a non-transitory machine-readable storage medium) and perform any one or more of the methodologies discussed herein. Specifically, Figure 10 shows a diagrammatic representation of hardware resources 1000 including one or more processors (or processor cores) 1010, one or more memory/storage devices 1020, and one or more communication resources 1030, each of which may be communicatively coupled via a bus 1040. For embodiments where node virtualization (e.g., NFV) is utilized, a hypervisor 1002 may be executed to provide an execution environment for one or more network slices/sub-slices to utilize the hardware resources 1000.

30

[00162] The processors 1010 may include, for example, a processor 1012 and a processor 1014. The processor(s) 1010 may be, for example, a central processing unit (CPU), a reduced instruction set computing (RISC) processor, a complex instruction set computing (CISC) processor, a graphics processing unit (GPU), a DSP such as a baseband processor, an ASIC, an FPGA, a radio-frequency integrated circuit (RFIC), another processor (including those discussed herein), or any suitable combination thereof.

[00163] The memory/storage devices 1020 may include main memory, disk storage, or any suitable combination thereof. The memory/storage devices 1020 may include, but are not limited to, any type of volatile or nonvolatile memory such as dynamic random access memory (DRAM), static random access memory (SRAM), erasable programmable read-only memory (EPROM), electrically erasable programmable read-only memory (EEPROM), Flash memory, solid-state storage, etc.

[00164] The communication resources 1030 may include interconnection or network interface components or other suitable devices to communicate with one or more peripheral devices 1004 or one or more databases 1006 via a network 1008. For example, the communication resources 1030 may include wired communication components (e.g., for coupling via USB), cellular communication components, NFC components, Bluetooth® (or Bluetooth® Low Energy) components, Wi-Fi® components, and other communication components.

[00165] Instructions 1050 may comprise software, a program, an application, an applet, an app, or other executable code for causing at least any of the processors 1010 to perform any one or more of the methodologies discussed herein. The instructions 1050 may reside, completely or partially, within at least one of the processors 1010 (e.g., within the processor's cache memory), the memory/storage devices 1020, or any suitable combination thereof. Furthermore, any portion of the instructions 1050 may be transferred to the hardware resources 1000 from any combination of the peripheral devices 1004 or the databases 1006. Accordingly, the memory of processors 1010, the memory/storage devices 1020, the peripheral devices 1004, and the databases 1006 are examples of computer-readable and machine-readable media.

[00166] Figure 11 illustrates various protocol functions that may be implemented in a wireless communication device according to various embodiments. In particular, Figure 11 includes an arrangement 1100 showing interconnections between various protocol layers/entities. The following description of Figure 11 is provided for various protocol layers/entities that operate in conjunction with the 5G/NR system standards and LTE system standards, but some or all of the aspects of Figure 11 may be applicable to other wireless communication network systems as well.

[00167] The protocol layers of arrangement 1100 may include one or more of PHY 1110, MAC 1120, RLC 1130, PDCP 1140, SDAP 1147, RRC 1155, and NAS layer 1157, in addition to other higher layer functions not illustrated. The protocol layers may include one or more service access points (e.g., items 1159, 1156, 1150, 1149, 1145, 1135, 1125, and 1115 in Figure 11) that may provide communication between two or more protocol layers.

[00168] The PHY 1110 may transmit and receive physical layer signals 1105 that may be received from or transmitted to one or more other communication devices. The physical layer signals 1105 may comprise one or more physical channels, such as those discussed herein. The PHY 1110 may further perform link adaptation or adaptive modulation and coding (AMC), power control, cell search (e.g., for initial synchronization and handover purposes), and other measurements used by higher layers, such as the RRC 1155. The PHY 1110 may still further perform error detection on the transport channels, forward error correction (FEC) coding/decoding of the transport channels, modulation/demodulation of physical channels, interleaving, rate matching, mapping onto physical channels, and MIMO antenna processing. In some embodiments, an instance of PHY 1110 may process requests from and provide indications to an instance of MAC 1120 via one or more PHY-SAP 1115. According to some embodiments, requests and indications communicated via PHY-SAP 1115 may comprise one or more transport channels.

[00169] Instance(s) of MAC 1120 may process requests from, and provide indications to, an instance of RLC 1130 via one or more MAC-SAPs 1125. These requests and indications

communicated via the MAC-SAP 1125 may comprise one or more logical channels. The MAC 1120 may perform mapping between the logical channels and transport channels, multiplexing of MAC SDUs from one or more logical channels onto TBs to be delivered to PHY 1110 via the transport channels, de-multiplexing MAC SDUs to one or more logical channels from TBs delivered from the PHY 1110 via transport channels, multiplexing MAC SDUs onto TBs, scheduling information reporting, error correction through HARQ, and logical channel prioritization.

[00170] Instance(s) of RLC 1130 may process requests from and provide indications to an instance of PDCP 1140 via one or more radio link control service access points (RLC-SAP) 1135. These requests and indications communicated via RLC-SAP 1135 may comprise one or more RLC channels. The RLC 1130 may operate in a plurality of modes of operation, including: Transparent Mode (TM), Unacknowledged Mode (UM), and Acknowledged Mode (AM). The RLC 1130 may execute transfer of upper layer protocol data units (PDUs), error correction through automatic repeat request (ARQ) for AM data transfers, and concatenation, segmentation and reassembly of RLC SDUs for UM and AM data transfers. The RLC 1130 may also execute re-segmentation of RLC data PDUs for AM data transfers, reorder RLC data PDUs for UM and AM data transfers, detect duplicate data for UM and AM data transfers, discard RLC SDUs for UM and AM data transfers, detect protocol errors for AM data transfers, and perform RLC re-establishment.

[00171] Instance(s) of PDCP 1140 may process requests from and provide indications to instance(s) of RRC 1155 and/or instance(s) of SDAP 1147 via one or more packet data convergence protocol service access points (PDCP-SAP) 1145. These requests and indications communicated via PDCP-SAP 1145 may comprise one or more radio bearers. The PDCP 1140 may execute header compression and decompression of IP data, maintain PDCP Sequence Numbers (SNs), perform in-sequence delivery of upper layer PDUs at re-establishment of lower layers, eliminate duplicates of lower layer SDUs at re-establishment of lower layers for radio bearers mapped on RLC AM, cipher and decipher control plane data, perform integrity protection and integrity verification of control plane data, control timer-based discard of data,

and perform security operations (e.g., ciphering, deciphering, integrity protection, integrity verification, etc.).

[00172] Instance(s) of SDAP 1147 may process requests from and provide indications to
5 one or more higher layer protocol entities via one or more SDAP-SAP 1149. These requests and
indications communicated via SDAP-SAP 1149 may comprise one or more QoS flows. The
SDAP 1147 may map QoS flows to DRBs, and vice versa, and may also mark QFIs in DL and
UL packets. A single SDAP entity 1147 may be configured for an individual PDU session. In the
10 UL direction, the NG-RAN 210 may control the mapping of QoS Flows to DRB(s) in two
different ways, reflective mapping or explicit mapping. For reflective mapping, the SDAP 1147
of a UE 201 may monitor the QFIs of the DL packets for each DRB, and may apply the same
mapping for packets flowing in the UL direction. For a DRB, the SDAP 1147 of the UE 201 may
map the UL packets belonging to the QoS flows(s) corresponding to the QoS flow ID(s) and
15 PDU session observed in the DL packets for that DRB. To enable reflective mapping, the NG-
RAN 410 may mark DL packets over the Uu interface with a QoS flow ID. The explicit mapping
may involve the RRC 1155 configuring the SDAP 1147 with an explicit QoS flow to DRB
mapping rule, which may be stored and followed by the SDAP 1147. In some embodiments, the
SDAP 1147 may only be used in NR implementations and may not be used in LTE
20 implementations.

[00173] The RRC 1155 may configure, via one or more management service access points
(M-SAP), aspects of one or more protocol layers, which may include one or more instances of
PHY 1110, MAC 1120, RLC 1130, PDCP 1140 and SDAP 1147. In some embodiments, an
instance of RRC 1155 may process requests from and provide indications to one or more NAS
25 entities 1157 via one or more RRC-SAPs 1156. The main services and functions of the RRC
1155 may include broadcast of system information (e.g., included in MIBs or SIBs related to the
NAS), broadcast of system information related to the access stratum (AS), paging, establishment,
maintenance and release of an RRC connection between the UE 201 and RAN 210 (e.g., RRC
connection paging, RRC connection establishment, RRC connection modification, and RRC
30 connection release), establishment, configuration, maintenance and release of point to point
Radio Bearers, security functions including key management, inter-RAT mobility, and

measurement configuration for UE measurement reporting. The MIBs and SIBs may comprise one or more IEs, which may each comprise individual data fields or data structures.

[00174] The NAS 1157 may form the highest stratum of the control plane between the UE 201 and the AMF 421. The NAS 1157 may support the mobility of the UEs 201 and the session management procedures to establish and maintain IP connectivity between the UE 201 and a P-GW in LTE systems.

[00175] According to various embodiments, one or more protocol entities of arrangement 1100 may be implemented in UEs 201, RAN nodes 211, AMF 421 in NR implementations or MME 321 in LTE implementations, UPF 402 in NR implementations or S-GW 322 and P-GW 323 in LTE implementations, or the like to be used for control plane or user plane communications protocol stack between the aforementioned devices. In such embodiments, one or more protocol entities that may be implemented in one or more of UE 201, gNB 211, AMF 421, etc. may communicate with a respective peer protocol entity that may be implemented in or on another device using the services of respective lower layer protocol entities to perform such communication. In some embodiments, a gNB-CU of the gNB 211 may host the RRC 1155, SDAP 1147, and PDCP 1140 of the gNB that controls the operation of one or more gNB-DUs, and the gNB-DUs of the gNB 211 may each host the RLC 1130, MAC 1120, and PHY 1110 of the gNB 211.

[00176] In a first example, a control plane protocol stack may comprise, in order from highest layer to lowest layer, NAS 1157, RRC 1155, PDCP 1140, RLC 1130, MAC 1120, and PHY 1110. In this example, upper layers 1160 may be built on top of the NAS 1157, which includes an IP layer 1161, an SCTP 1162, and an application layer signaling protocol (AP) 1163.

[00177] In NR implementations, the AP 1163 may be an NG application protocol layer (NGAP or NG-AP) 1163 for the NG interface 213 defined between the NG-RAN node 211 and the AMF 421, or the AP 1163 may be an Xn application protocol layer (XnAP or Xn-AP) 1163 for the Xn interface 212 that is defined between two or more RAN nodes 211.

[00178] The NG-AP 1163 may support the functions of the NG interface 213 and may comprise Elementary Procedures (EPs). An NG-AP EP may be a unit of interaction between the NG-RAN node 211 and the AMF 421. The NG-AP 1163 services may comprise two groups: UE-associated services (e.g., services related to a UE 201) and non-UE-associated services (e.g., services related to the whole NG interface instance between the NG-RAN node 211 and AMF 421). These services may include functions including, but not limited to: a paging function for the sending of paging requests to NG-RAN nodes 211 involved in a particular paging area; a UE context management function for allowing the AMF 421 to establish, modify, and/or release a UE context in the AMF 421 and the NG-RAN node 211; a mobility function for UEs 201 in ECM-CONNECTED mode for intra-system HOs to support mobility within NG-RAN and inter-system HOs to support mobility from/to EPS systems; a NAS Signaling Transport function for transporting or rerouting NAS messages between UE 201 and AMF 421; a NAS node selection function for determining an association between the AMF 421 and the UE 201; NG interface management function(s) for setting up the NG interface and monitoring for errors over the NG interface; a warning message transmission function for providing means to transfer warning messages via NG interface or cancel ongoing broadcast of warning messages; a Configuration Transfer function for requesting and transferring of RAN configuration information (e.g., SON information, performance measurement (PM) data, etc.) between two RAN nodes 211 via CN 220; and/or other like functions.

20

[00179] The XnAP 1163 may support the functions of the Xn interface 212 and may comprise XnAP basic mobility procedures and XnAP global procedures. The XnAP basic mobility procedures may comprise procedures used to handle UE mobility within the 5G NR RAN 211 (or E-UTRAN 310), such as handover preparation and cancellation procedures, SN Status Transfer procedures, UE context retrieval and UE context release procedures, RAN paging procedures, dual connectivity related procedures, and the like. The XnAP global procedures may comprise procedures that are not related to a specific UE 201, such as Xn interface setup and reset procedures, NG-RAN update procedures, cell activation procedures, and the like.

30

[00180] In LTE implementations, the AP 1163 may be an S1 Application Protocol layer (S1-AP) 1163 for the S1 interface 213 defined between an E-UTRAN node 211 and an MME, or the AP 1163 may be an X2 application protocol layer (X2AP or X2-AP) 1163 for the X2 interface 212 that is defined between two or more E-UTRAN nodes 211.

5

[00181] The S1 Application Protocol layer (S1-AP) 1163 may support the functions of the S1 interface, and similar to the NG-AP discussed previously, the S1-AP may comprise S1-AP EPs. An S1-AP EP may be a unit of interaction between the E-UTRAN node 211 and an MME 321 within an LTE CN 220. The S1-AP 1163 services may comprise two groups: UE-associated services and non UE-associated services. These services perform functions including, but not limited to: E-UTRAN Radio Access Bearer (E-RAB) management, UE capability indication, mobility, NAS signaling transport, RAN Information Management (RIM), and configuration transfer.

10

15

[00182] The X2AP 1163 may support the functions of the X2 interface 212 and may comprise X2AP basic mobility procedures and X2AP global procedures. The X2AP basic mobility procedures may comprise procedures used to handle UE mobility within the E-UTRAN 220, such as handover preparation and cancellation procedures, SN Status Transfer procedures, UE context retrieval and UE context release procedures, RAN paging procedures, dual connectivity related procedures, and the like. The X2AP global procedures may comprise procedures that are not related to a specific UE 201, such as X2 interface setup and reset procedures, load indication procedures, error indication procedures, cell activation procedures, and the like.

20

25

[00183] The SCTP layer (alternatively referred to as the SCTP/IP layer) 1162 may provide guaranteed delivery of application layer messages (e.g., NGAP or XnAP messages in NR implementations, or S1-AP or X2AP messages in LTE implementations). The SCTP 1162 may ensure reliable delivery of signaling messages between the RAN node 211 and the AMF 421/MME 321 based, in part, on the IP protocol, supported by the IP 1161. The Internet Protocol layer (IP) 1161 may be used to perform packet addressing and routing functionality. In some

30

implementations the IP layer 1161 may use point-to-point transmission to deliver and convey PDUs. In this regard, the RAN node 211 may comprise L2 and L1 layer communication links (e.g., wired or wireless) with the MME/AMF to exchange information.

5 [00184] In a second example, a user plane protocol stack may comprise, in order from highest layer to lowest layer, SDAP 1147, PDCP 1140, RLC 1130, MAC 1120, and PHY 1110. The user plane protocol stack may be used for communication between the UE 201, the RAN node 211, and UPF 402 in NR implementations or an S-GW 322 and P-GW 323 in LTE implementations. In this example, upper layers 1151 may be built on top of the SDAP 1147, and
10 may include a user datagram protocol (UDP) and IP security layer (UDP/IP) 1152, a General Packet Radio Service (GPRS) Tunneling Protocol for the user plane layer (GTP-U) 1153, and a User Plane PDU layer (UP PDU) 1163.

[00185] The transport network layer 1154 (also referred to as a “transport layer”) may be
15 built on IP transport, and the GTP-U 1153 may be used on top of the UDP/IP layer 1152 (comprising a UDP layer and IP layer) to carry user plane PDUs (UP-PDUs). The IP layer (also referred to as the “Internet layer”) may be used to perform packet addressing and routing functionality. The IP layer may assign IP addresses to user data packets in any of IPv4, IPv6, or PPP formats, for example.

20

[00186] The GTP-U 1153 may be used for carrying user data within the GPRS core network and between the radio access network and the core network. The user data transported can be packets in any of IPv4, IPv6, or PPP formats, for example. The UDP/IP 1152 may provide checksums for data integrity, port numbers for addressing different functions at the
25 source and destination, and encryption and authentication on the selected data flows. The RAN node 211 and the S-GW 322 may utilize an S1-U interface to exchange user plane data via a protocol stack comprising an L1 layer (e.g., PHY 1110), an L2 layer (e.g., MAC 1120, RLC 1130, PDCP 1140, and/or SDAP 1147), the UDP/IP layer 1152, and the GTP-U 1153. The S-GW 322 and the P-GW 323 may utilize an S5/S8a interface to exchange user plane data via a
30 protocol stack comprising an L1 layer, an L2 layer, the UDP/IP layer 1152, and the GTP-U 1153. As discussed previously, NAS protocols may support the mobility of the UE 201 and the session

management procedures to establish and maintain IP connectivity between the UE 201 and the P-GW 323.

5 [00187] Moreover, although not shown by Figure 11, an application layer may be present above the AP 1163 and/or the transport network layer 1154. The application layer may be a layer in which a user of the UE 201, RAN node 211, or other network element interacts with software applications being executed, for example, by application circuitry 505 or application circuitry 605, respectively. The application layer may also provide one or more interfaces for software applications to interact with communications systems of the UE 201 or RAN node 211, such as 10 the baseband circuitry 710. In some implementations the IP layer and/or the application layer may provide the same or similar functionality as layers 5-7, or portions thereof, of the Open Systems Interconnection (OSI) model (e.g., OSI Layer 7 – the application layer, OSI Layer 6 – the presentation layer, and OSI Layer 5 – the session layer).

15 [00188] Figure 12 is a signaling diagram illustrating the flow of information for enabling application clients to experience service continuity while switching application servers when a change in Edge Data Network is performed according to various exemplary embodiments. In some embodiments, the Application Client (AC) 1250 and the Application Client Handler (ACH) 1252 reside on the UE (e.g., UEs 201, 301, 401) and the remainder of the components are 20 located within the network. The AC 1250 and the ACH 1252 may, for example, be a set of instructions on the memory circuitry 620 whose functions are performed by the application circuitry 602 of the UE. In some embodiments, the application server handlers may be a set of instructions stored on the memory circuitry 520 of an application server 230 and performed by the application circuitry 505. For example, in the following description, the original ASH 1256 25 may be a set of instructions store on and performed by the original AS 1258. Similarly, the new ASH 1260 may be a set of instructions stored on and performed by the new AS 1262. In some embodiments, the application server handlers may alternatively be stored remotely, such as, for example, on one or more of the plurality of network elements 222 of the CN 220 and performed by the application servers 230 (e.g., AS 1258, 1262 in the following description).

30 [00189] At 1201, the ACH 1252 of the UE connects to the corresponding Application Server Handler (ASH) 1256 in the designated Edge Data Network (DN). The UE-ID is provided

to enable the ASH 1256 to associate future AC-IDs with the UE-ID (see 1203). This operation may occur a single time, during the attachment of the UE to the network. At 1202, the AC 1250 that requires Edge Mobility service, registers with the ACH 1252 to receive future mobility event triggers. The AC 1250 provides the ID of the Application Server (AS) with which it will interact.

5 This allows for future detection of which Application Servers may perform context mirroring as a result of a mobility event. In this exemplary message flow, one AC 1250 registration is described, but there may be several ACs that register at different times.

[00190] At 1203, the ACH 1252 updates the ASH 1256 of the new registration, providing
10 the AC-ID of the new client. This is to identify the AC's 1250 context to be mirrored when a mobility event occurs. At 1204, the ACH 1252 acknowledges the successful registration. At 1205, the AC 1250 connects to the serving Application Server (AS) 1258 which is deployed in designated Edge DN. At 1206, a Mobility Event Occurs. As a result of the UE moving to a
15 different point of attachment which is better served by a different Edge DN, the new Edge DN identified by a target DNAI is assigned. An Early (or Late) notification (as specified in 3GPP TS 23.501) may be generated by the 5G Core Network 1254 and sent to the original ASH 1256 with the DNAI of the new ASH 1260 to trigger the transition. At 1207, the original ASH 1256
collects the AS-IDs of all Application Servers (e.g., AS 1258) that serve Application Clients
(e.g., 1250) in the moving UE (provided in 1202) and issues a transition request to each of those
20 servers. The original ASH 1256 provides the AC-ID so that the original AS 1258 knows which context to transfer.

[00191] At 1208, the original ASH 1256 sends a Transition Request to the new ASH 1260
in the new Edge DN and provides the UE-ID along with the AS-IDs of all participating
25 Application Servers (e.g., AS 1258) to trigger the mirroring process. Each original AS (e.g., AS 1258) will issue the AC-ID of the client whose context is mirrored to the corresponding new AS 1262. At 1209, the new ASH 1260 issues transition requests to all new Application Servers (e.g., AS 1262) that should perform mirroring. The old AS-ID (oAS-ID) is provided to each new AS
(e.g., AS 1262), along with the UE-ID, to enable the new AS 1262 to connect to its counterpart
30 (e.g., AS 1258) in the old Edge DN. At 1210, the new Application Servers (e.g., new AS 1262) start mirroring. At 1211, the original Application Servers (e.g., AS 1258) indicate to the original ASH 1256 that mirroring has begun. At 1212, since all mirroring processes have begun, the

original ASH 1256 sends an acknowledgement of the mobility event to the 5G Core Network 1254. At 1213, the original ASH 1256 sends a Mobility Event notification to the ACH 1252 and provides the new ASH-ID and the list of new AS-IDs. At 1214, the ACH 1252 connects to the new ASH 1260 and provides the list of AS-IDs and AC-IDs corresponding to the servers, to
5 enable future mobility support. This is a repeat of 1201 and multiple 1203s.

[00192] At 1215, the Application Clients 1250 are notified of the mobility event and each receives the IP address of the AS (e.g., new AS 1262) to which it should connect. At 1216, each AC 1250 disconnects from the original AS 1258 and connects to the new AS 1262 (this is
10 implementation-specific). In some UE implementations 1215 and 1216 may be skipped, provided that the ACH 1252 is able to hide the mobility event from the application client. At 1217, each new AS (e.g., new AS 1262) informs the new ASH 1260 of the completion of the mirroring process. The process with the corresponding original AS 1258 is also terminated. At 1218, the new ASH 1260 informs the original ASH 1256 of the transition completion. At 1219,
15 the original ASH 1256 informs the 5G Core Network 1254 that the transition has completed.

Examples

[00193] Example 1 may include the Application Client Enabler registers to the AS
20 Handler for the Mobility Event notification by including the UE ID.

[00194] Example 2 may include the method of example 1 or some other example herein, when receiving the notification message (e.g. from the 5G System) including target DNAI and User Identifier, the old AS Handler determines the new AS Handler based on the target DNAI
25 and sends a Transition Request to the new AS Handler by including the old AS ID and UE ID.

[00195] Example 3 may include the method of example 2 or some other example herein, wherein the new AS Handler further sends a Transition Request to the new AS by including the UE ID and the old AS-ID.
30

[00196] Example 4 may include the method of example 3 or some other example herein, wherein after receiving the Transition Response, the old AS Handler notifies the Application Client Handler about the identifier of the new Application Server(s) and the identifier of the new AS Handler.

5

[00197] Example 5 may include the method of example 4 or some other example herein, wherein the Application Client Handler further notifies the Application Client about the identifier of the new AS and the UE ID.

10 [00198] Example 6 may include the method of example 1 or some other example herein, wherein the UE ID is a GPSI.

[00199] Example 7 may include the method of example 1 or some other example herein, the UE ID is an external identifier.

15

[00200] Example 8 may include the method of example 2 or some other example herein, wherein the identifier of the old AS is a FQDN.

[00201] Example 9 may include the method of example 2 or some other example herein, 20 wherein the identifier of the old AS is an IP Address.

[00202] Example 10 may include the method of example 2 or some other example herein, wherein the identifier of the old AS is other format of identifier.

25 [00203] Example 11 may include the method of example 4 or some other example herein, wherein the identifier of the new Application Server and the new AS Handler is a FQDN.

[00204] Example 12 may include the method of example 4 or some other example herein, wherein the identifier of the new Application Server and the new AS Handler is an IP address.

30

[00205] Example 13 may include the method of example 4 or some other example herein, wherein the identifier of the new Application Server and the new AS Handler is other format of identifier.

5 [00206] Example 14 may include the method of example 4 or some other example herein, wherein the Client Handler registers to the new AS Handler by including UE ID.

[00207] Example 15 may include the method of example 14 or some other example herein, wherein the new AS Handler sends a Transition Complete to the old AS Handler by
10 including UE ID.

[00208] Example 16 may include the method of example 15 or some other example herein, wherein the old AS Handler triggers release the Session Context in the old AS.

15 [00209] Example 17 may include a method comprising: receiving an application ID (AC-ID) associated with an application client for a UE; receiving a mobility event notification including a UE ID of the UE and a target DNAI to indicate a target Edge data network to which a transition of a data connection for the application client is to be performed; encoding an outgoing transition request for transmission to a source application server to indicate the transition of the
20 data connection from the source application server; and encoding an incoming transition request for transmission to a target application server handler (ASH) of the target Edge data network to indicate the transition of the data connection to the target Edge data network.

[00210] Example 18 may include the method of example 17 or another example herein,
25 wherein the outgoing transition request includes the AC-ID.

[00211] Example 19 may include the method of example 17-18 or another example herein, wherein the incoming transition request includes an application server ID (AS-ID) of the source application server and the UE-ID.

30

[00212] Example 20 may include the method of example 17-19 or another example herein, wherein the mobility event notification is received from a 5G core network.

[00213] Example 21 may include the method of example 17-20 or another example herein,
5 wherein the AC-ID is received from a client handler of the UE.

[00214] Example 22 may include the method of example 17-21 or another example herein, further comprising receiving a notification that the transition has been started.

10 [00215] Example 23 may include the method of example 22 or another example herein, wherein the notification is received from the source application server.

[00216] Example 24 may include the method of example 22-23 or another example herein, further comprising encoding for transmission to a 5G core network an acknowledgement of the
15 mobility event notification responsive to receive of the notification that the transition has been started.

[00217] Example 25 may include the method of example 17-24 or another example herein, further comprising encoding for transmission to a client handler of the UE an indication of a
20 target application server handler (ASH) of the target Edge data network.

[00218] Example 26 may include the method of example 17-25 or another example herein, further comprising receiving an indication from the target application server handler that the
25 transition has been completed.

[00219] Example 27 may include the method of example 26 or another example herein, further comprising encoding for transmission to the 5G core network an indication that the transition is completed.

[00220] Example 28 may include the method of example 17-27 or another example herein, wherein the AC-ID is included in an app usage notification that further includes an application server ID of the source application server.

5 [00221] Example 29 may include the method of example 17-28 or another example herein, wherein the method is performed by a source application server handler associated with the source Edge data network, or a portion thereof.

[00222] Example 30 may include a method comprising: receiving an outgoing transition request from a source application server handler (ASH) of a source Edge data network to indicate a transition of a data connection for an application run by a UE from the source Edge data network to a target Edge data network, wherein the outgoing transition request includes an application ID (AC-ID) of the application; and performing, based on the outgoing transition request, context mirroring with a target application server of the target application network to provide UE context information associated with the application to the target application network.

10
15

[00223] Example 31 may include the method of example 30 or another example herein, further comprising encoding for transmission to the source ASH, a notification to indicate that the transition has started.

20 [00224] Example 32 may include the method of example 31 or another example herein, wherein the notification is transmitted after performance of the context mirroring.

[00225] Example 33 may include the method of example 30-32 or another example herein, wherein the method is performed by a source application server of the source Edge data network, or a portion thereof.

25

[00226] Example 34 may include an apparatus comprising means to perform one or more elements of a method described in or related to any of examples 1-33, or any other method or process described herein.

30

[00227] Example 35 may include one or more non-transitory computer-readable media comprising instructions to cause an electronic device, upon execution of the instructions by one or more processors of the electronic device, to perform one or more elements of a method described in or related to any of examples 1-33, or any other method or process described herein.

5

[00228] Example 36 may include an apparatus comprising logic, modules, or circuitry to perform one or more elements of a method described in or related to any of examples 1-33, or any other method or process described herein.

10 [00229] Example 37 may include a method, technique, or process as described in or related to any of examples 1-33, or portions or parts thereof.

[00230] Example 38 may include an apparatus comprising: one or more processors and one or more computer-readable media comprising instructions that, when executed by the one or
15 more processors, cause the one or more processors to perform the method, techniques, or process as described in or related to any of examples 1-33, or portions thereof.

[00231] Example 39 may include a signal as described in or related to any of examples 1-
20 33, or portions or parts thereof.

20

[00232] Example 40 may include a datagram, packet, frame, segment, protocol data unit (PDU), or message as described in or related to any of examples 1-33, or portions or parts thereof, or otherwise described in the present disclosure.

25 [00233] Example 41 may include a signal encoded with data as described in or related to any of examples 1-33, or portions or parts thereof, or otherwise described in the present disclosure.

[00234] Example 42 may include a signal encoded with a datagram, packet, frame,
30 segment, protocol data unit (PDU), or message as described in or related to any of examples 1-33, or portions or parts thereof, or otherwise described in the present disclosure.

[00235] Example 43 may include an electromagnetic signal carrying computer-readable instructions, wherein execution of the computer-readable instructions by one or more processors is to cause the one or more processors to perform the method, techniques, or process as described in or related to any of examples 1-33, or portions thereof.

[00236] Example 44 may include a computer program comprising instructions, wherein execution of the program by a processing element is to cause the processing element to carry out the method, techniques, or process as described in or related to any of examples 1-33, or portions thereof.

[00237] Example 45 may include a signal in a wireless network as shown and described herein.

[00238] Example 46 may include a method of communicating in a wireless network as shown and described herein.

[00239] Example 47 may include a system for providing wireless communication as shown and described herein.

[00240] Example 48 may include a device for providing wireless communication as shown and described herein.

[00241] Any of the above-described examples may be combined with any other example (or combination of examples), unless explicitly stated otherwise. The foregoing description of one or more implementations provides illustration and description but is not intended to be exhaustive or to limit the scope of embodiments to the precise form disclosed. Modifications and variations are possible in light of the above teachings or may be acquired from practice of various embodiments.

[00242] Those skilled in the art will understand that the above-described exemplary embodiments may be implemented in any suitable software or hardware configuration or combination thereof. An exemplary hardware platform for implementing the exemplary embodiments may include, for example, an Intel x86 based platform with compatible operating system, a Windows OS, a Mac platform and MAC OS, a mobile device having an operating system such as iOS, Android, etc. In a further example, the exemplary embodiments of the above described method may be embodied as a program containing lines of code stored on a non-transitory computer readable storage medium that, when compiled, may be executed on a processor or microprocessor.

10

[00243] It is well understood that the use of personally identifiable information should follow privacy policies and practices that are generally recognized as meeting or exceeding industry or governmental requirements for maintaining the privacy of users. In particular, personally identifiable information data should be managed and handled so as to minimize risks of unintentional or unauthorized access or use, and the nature of authorized use should be clearly indicated to users.

15

[00244] It will be apparent to those skilled in the art that various modifications may be made in the present disclosure, without departing from the spirit or the scope of the disclosure. Thus, it is intended that the present disclosure cover modifications and variations of this disclosure provided they come within the scope of the appended claims and their equivalent.

20

Claims

1. A method, comprising:
 - receiving an application ID (AC-ID) associated with an application client for a user
5 equipment (UE);
 - receiving a mobility event notification including a UE ID of the UE and a target data
network access identifier (DNAI) to indicate a target edge data network to which a transition of a
data connection for the application client is to be performed;
 - encoding an outgoing transition request for transmission to a source application server to
10 indicate the transition of the data connection from the source application server; and
 - encoding an incoming transition request for transmission to a target application server
handler (ASH) of the target edge data network to indicate the transition of the data connection to
the target edge data network.
- 15 2. The method of claim 1, wherein the outgoing transition request includes the AC-ID.
3. The method of claim 1, wherein the incoming transition request includes an application
server ID (AS-ID) for the source application server and the UE-ID.
- 20 4. The method of claim 1, wherein the mobility event notification is received from a 5G
core network.
5. The method of claim 1, wherein the AC-ID is received from a client handler of the UE.
- 25 6. The method of claim 1, further comprising:
 - receiving a notification that the transition has started.
7. The method of claim 6, wherein the notification is received from the source application
server.

30

8. The method of claim 6, further comprising:
encoding for transmission to a 5G core network an acknowledgement of the mobility event notification responsive to receipt of the notification that the transition has started.
- 5 9. The method of claim 6, further comprising:
encoding for transmission to a client handler of the UE an indication of a target application server handler (ASH) of the target edge data network.
10. The method of claim 1, further comprising:
10 receiving an indication from the target application server handler that the transition has been completed.
11. The method of claim 10, further comprising:
encoding for transmission to the 5G core network an indication that the transition is
15 completed.
12. The method of claim 1, wherein the AC-ID is included in an application usage notification that further includes an application server ID of the source application server.
- 20 13. The method of claim 1, wherein the method is performed by a source application server handler associated with the source Edge data network, or a portion thereof.
14. An apparatus that is implemented in or employed by a server and configured to perform any of the methods of claims 1-13.
- 25 15. A method, comprising:
receiving an outgoing transition request from a source application server handler (ASH) of a source Edge data network to indicate a transition of a data connection for an application run by a UE from the source Edge data network to a target Edge data network, wherein the outgoing
30 transition request includes an application ID (AC-ID) of the application; and

performing, based on the outgoing transition request, context mirroring with a target application server of the target application network to provide the UE context information associated with the application to the target application network.

- 5 16. The method of claim 15, further comprising:
encoding for transmission to the source ASH, a notification to indicate that the transition
has started.
17. The method of claim 16, wherein the notification is transmitted after performance of the
10 context mirroring.
18. The method of claim 15, wherein the method is performed by a source application server
of the source edge data network.
- 15 19. An apparatus that is implemented in or employed by a server and configured to perform
any of the methods of claims 15-18.

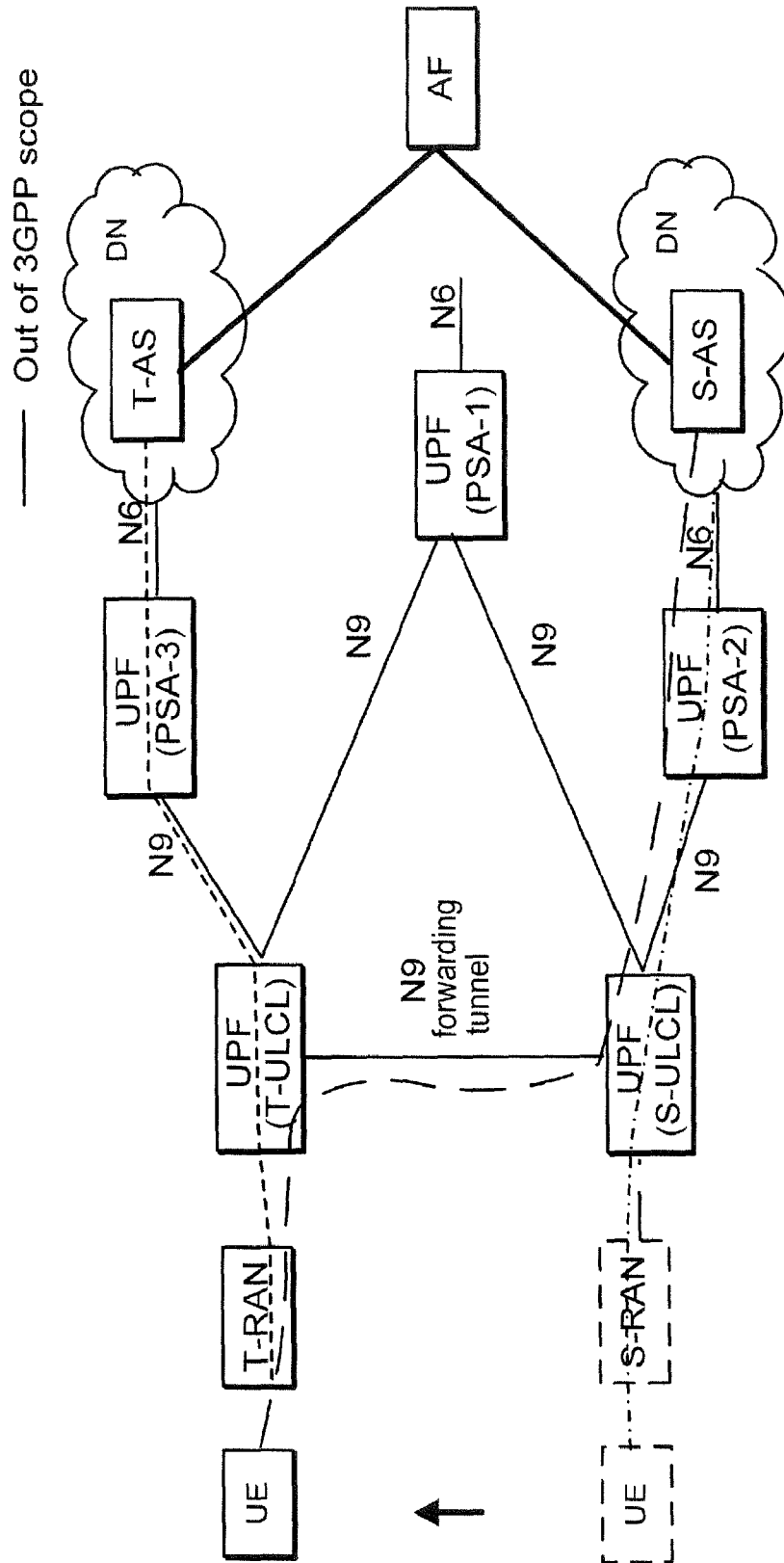

Fig. 1 (Prior Art)

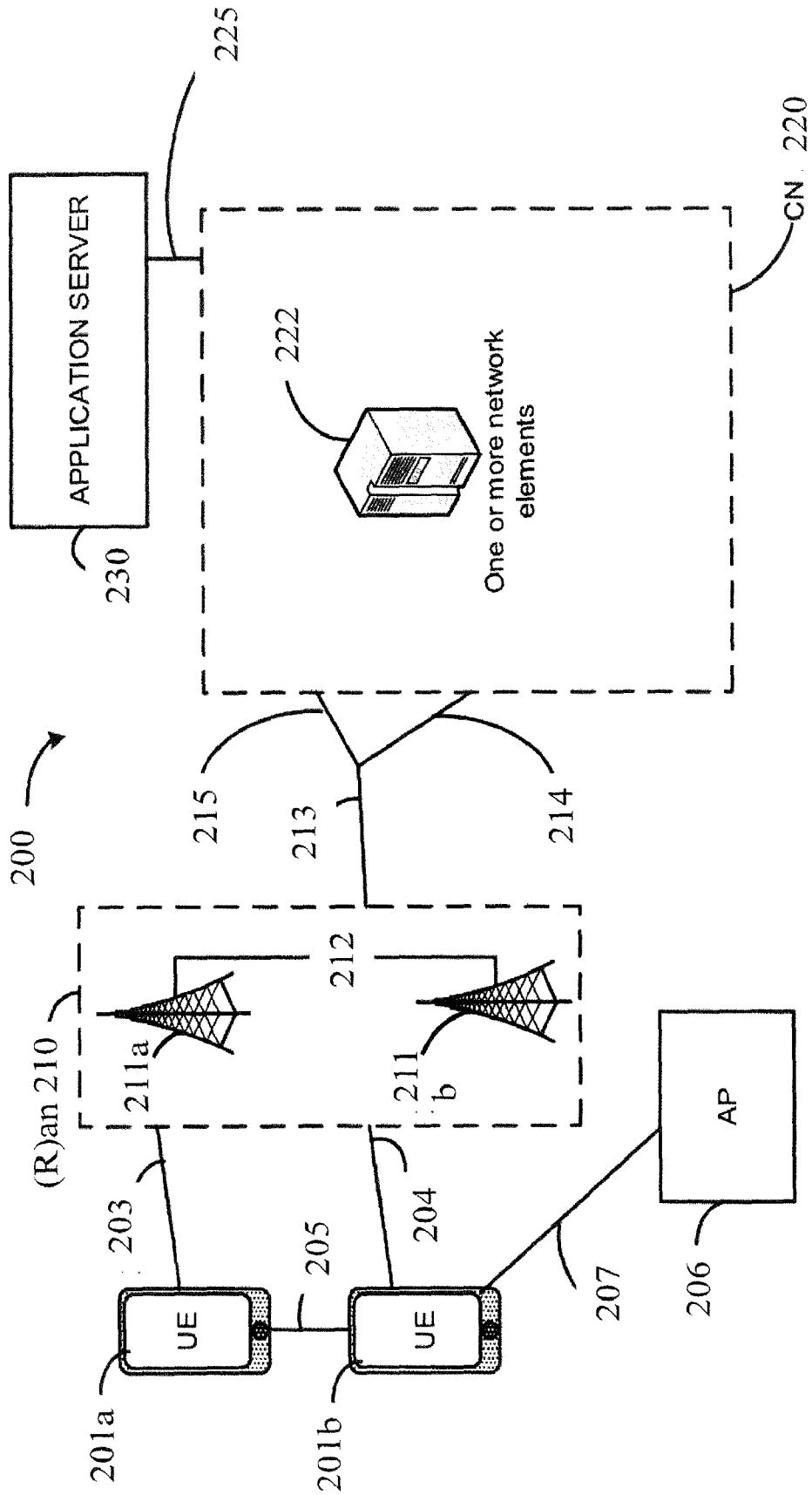

Fig. 2

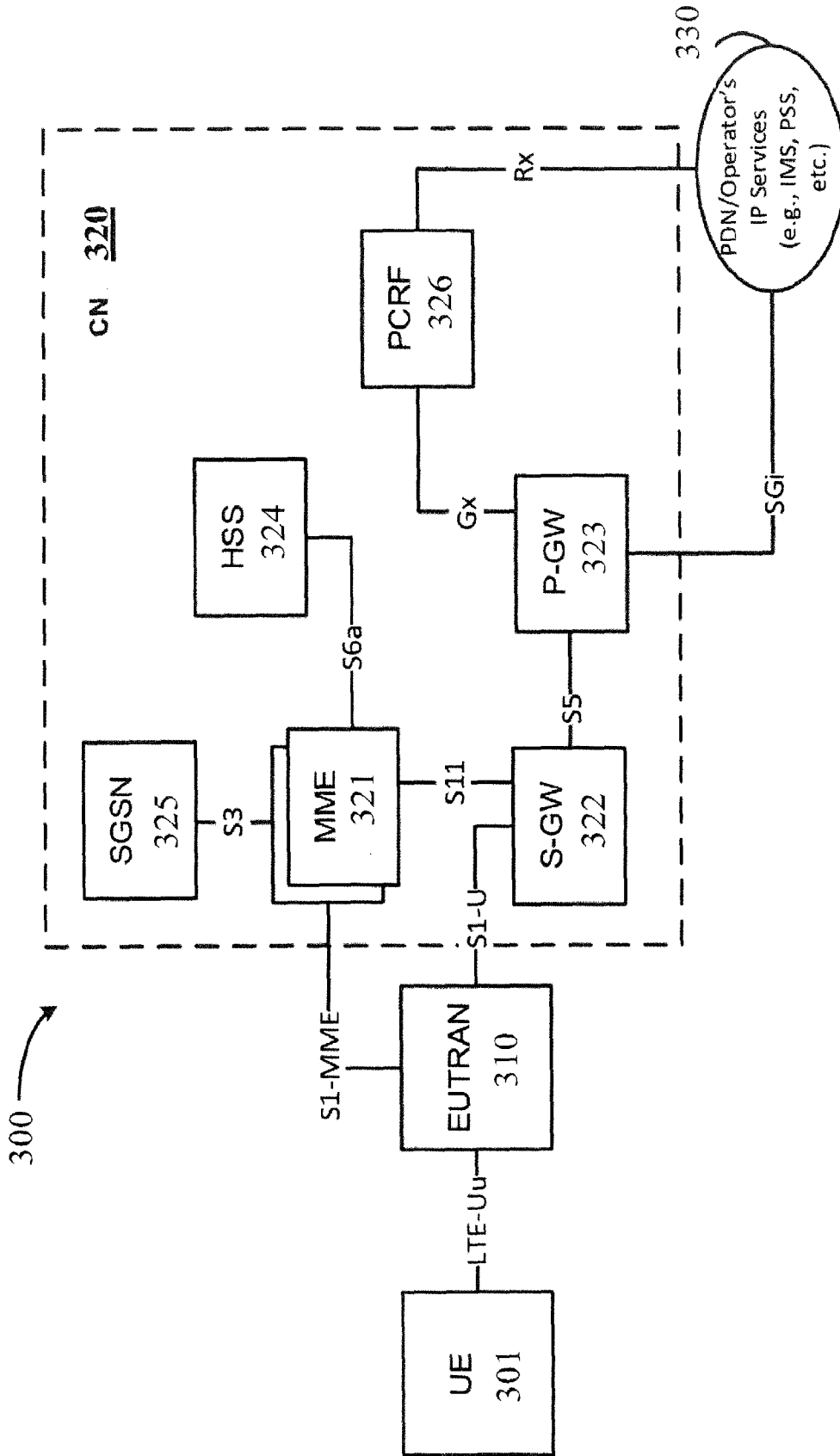

Fig. 3

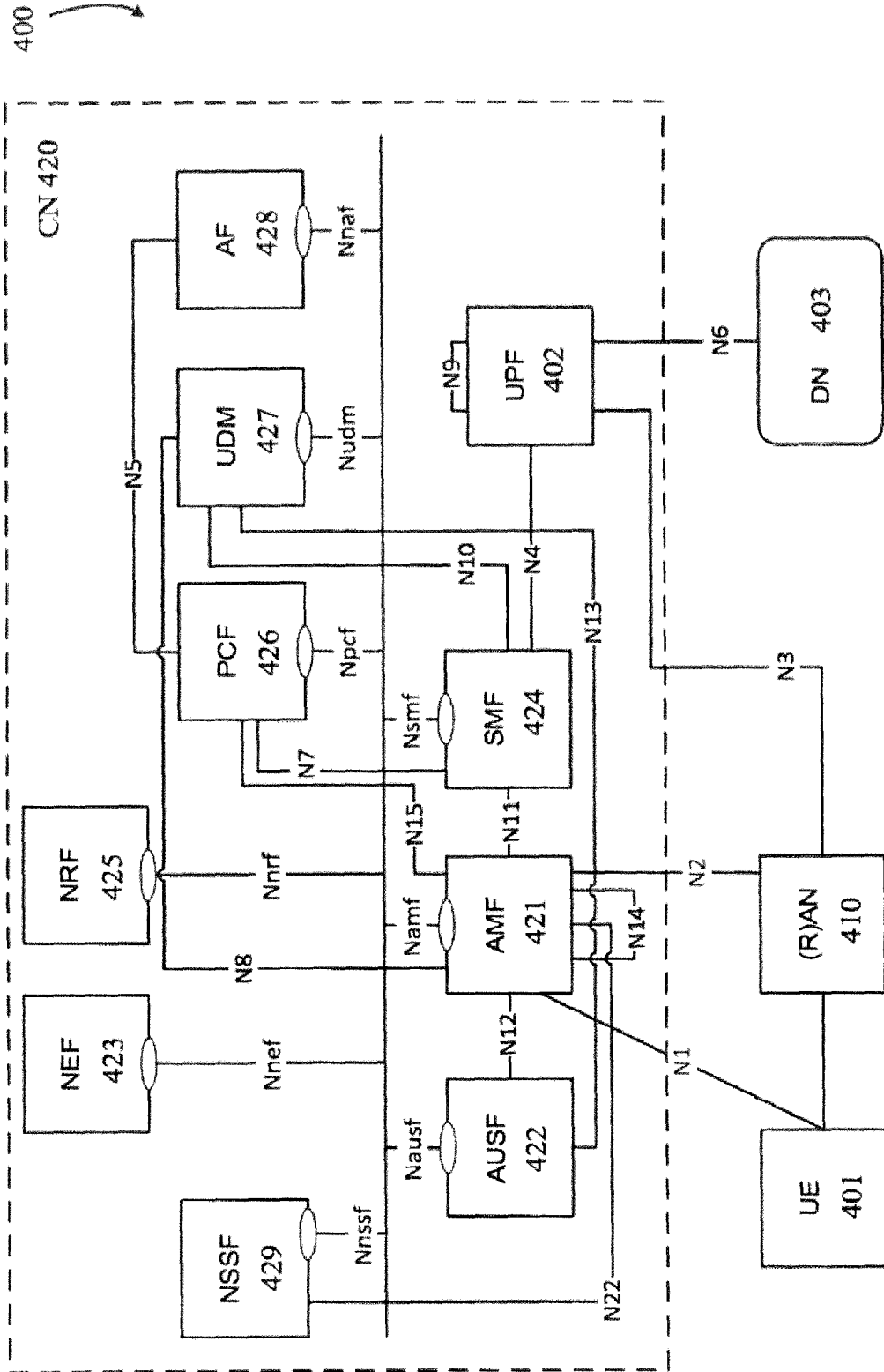

Fig. 4

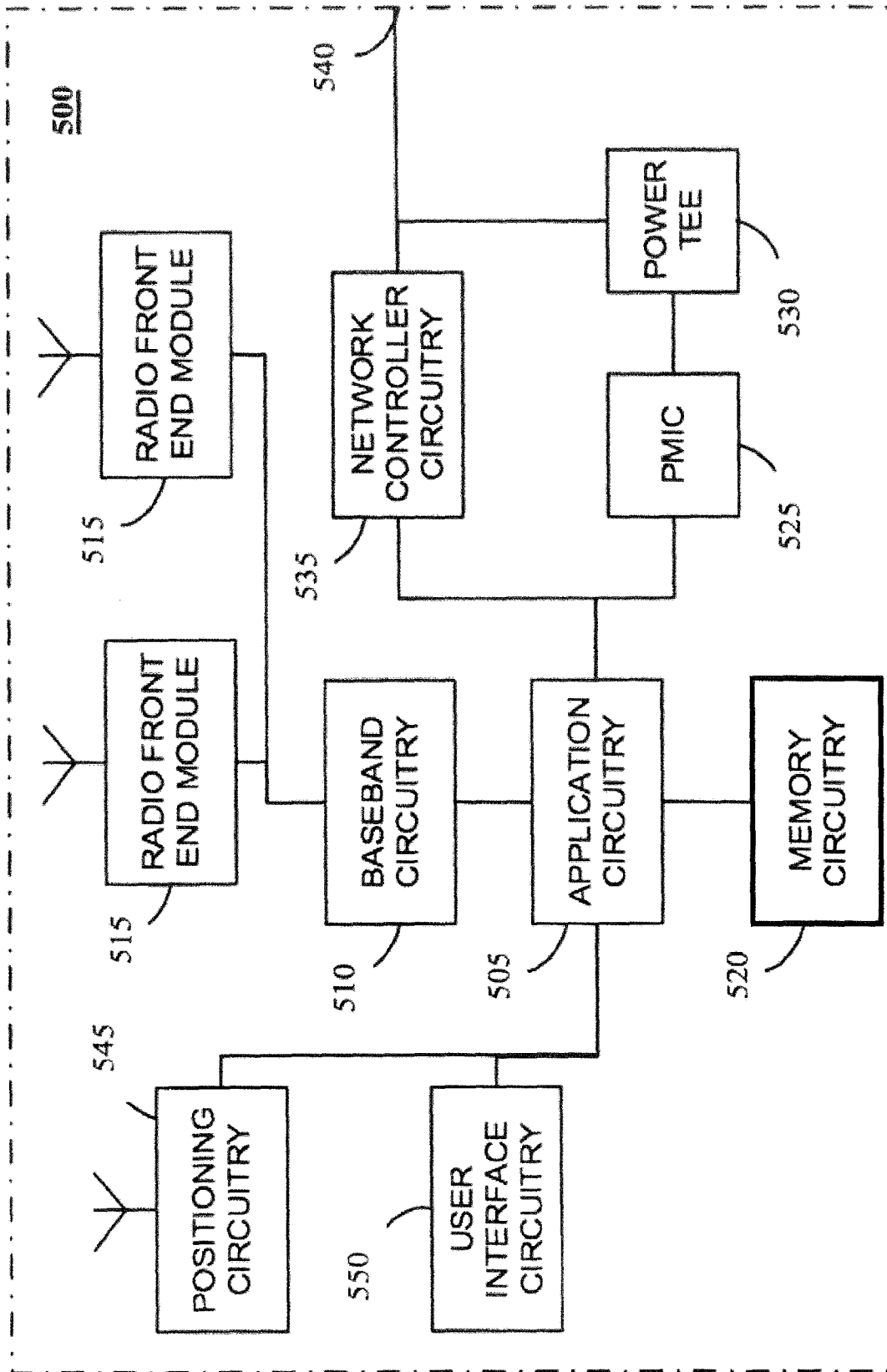

Fig. 5

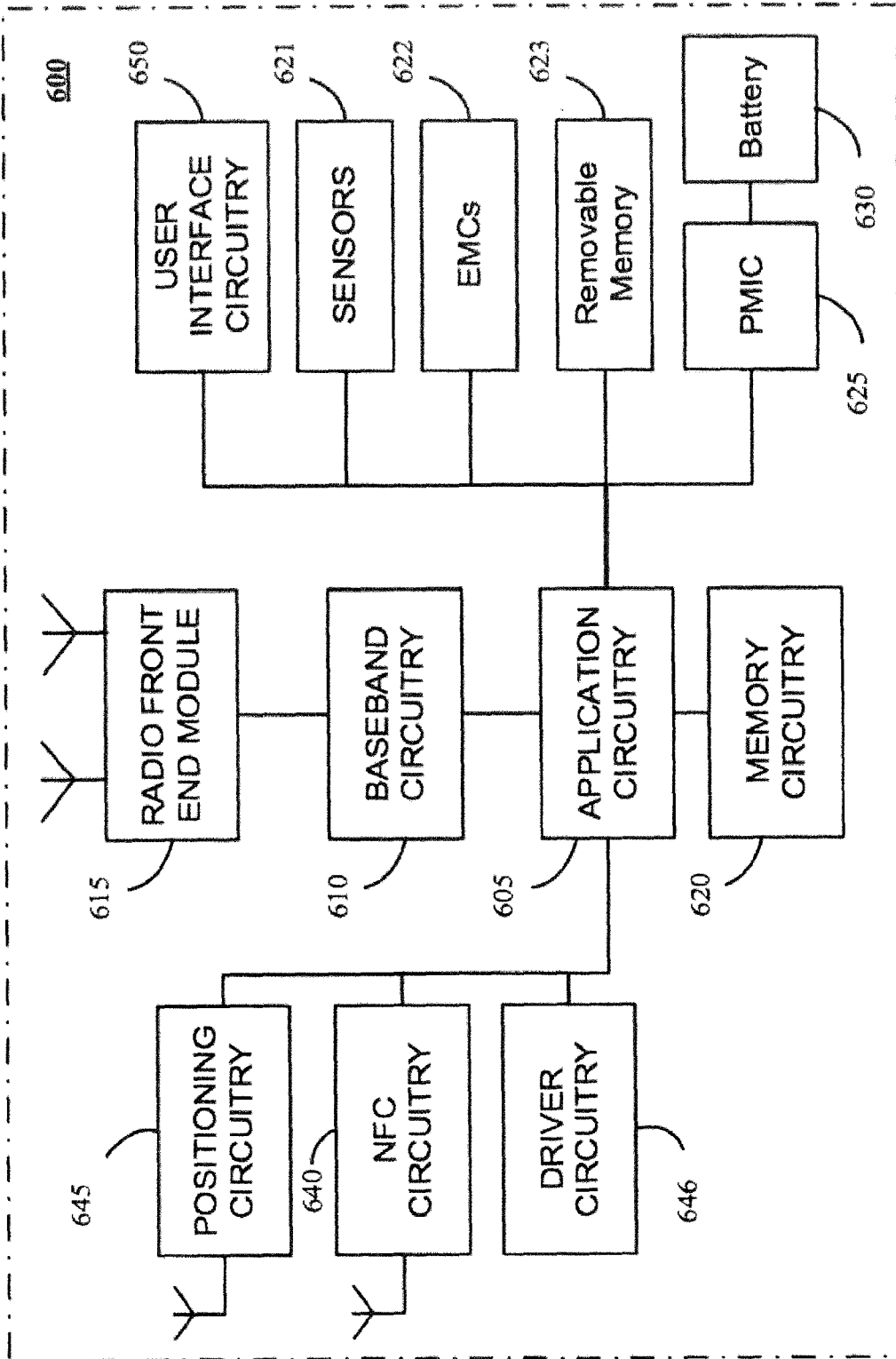

Fig. 6

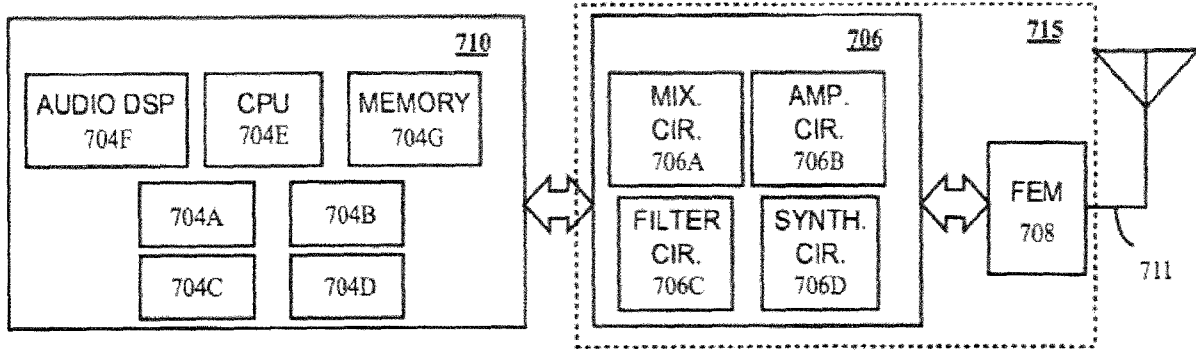

Fig. 7

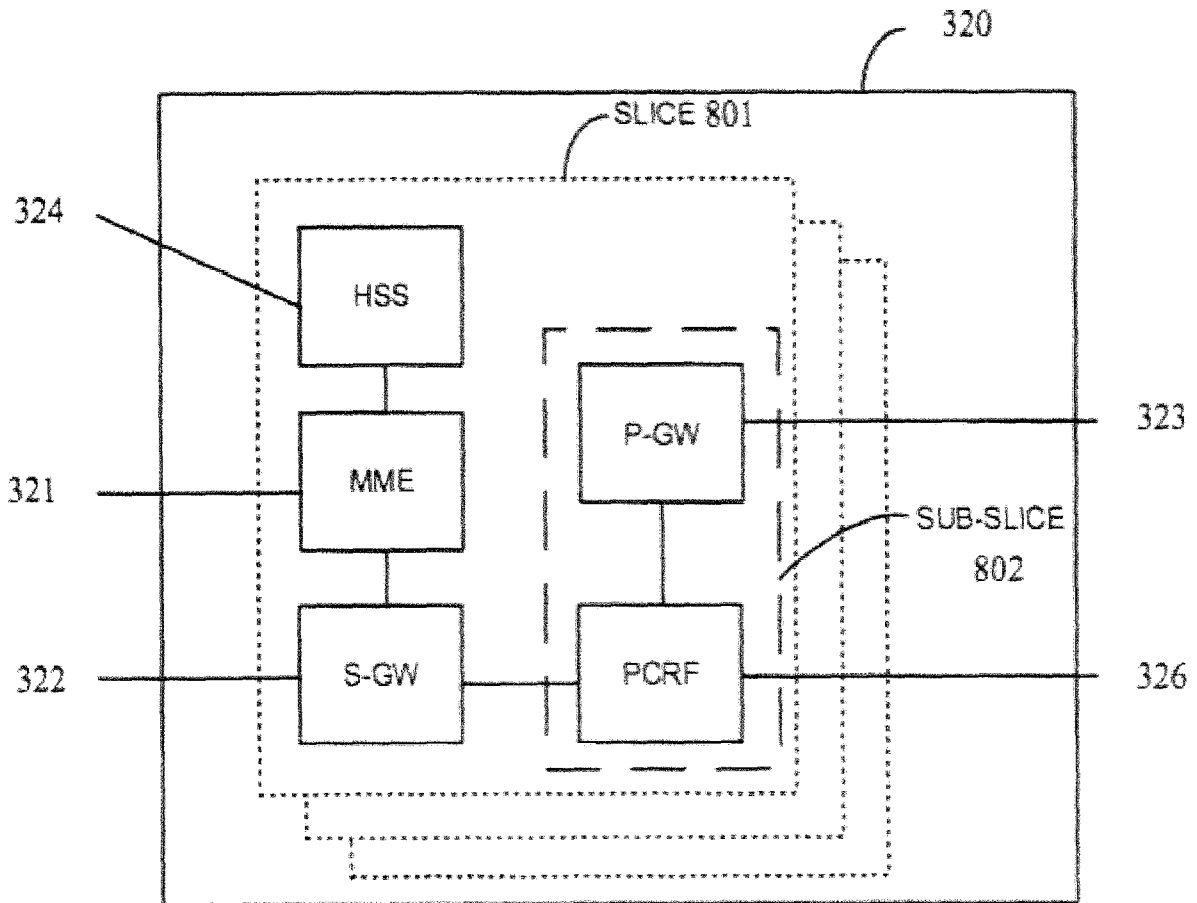

Fig. 8

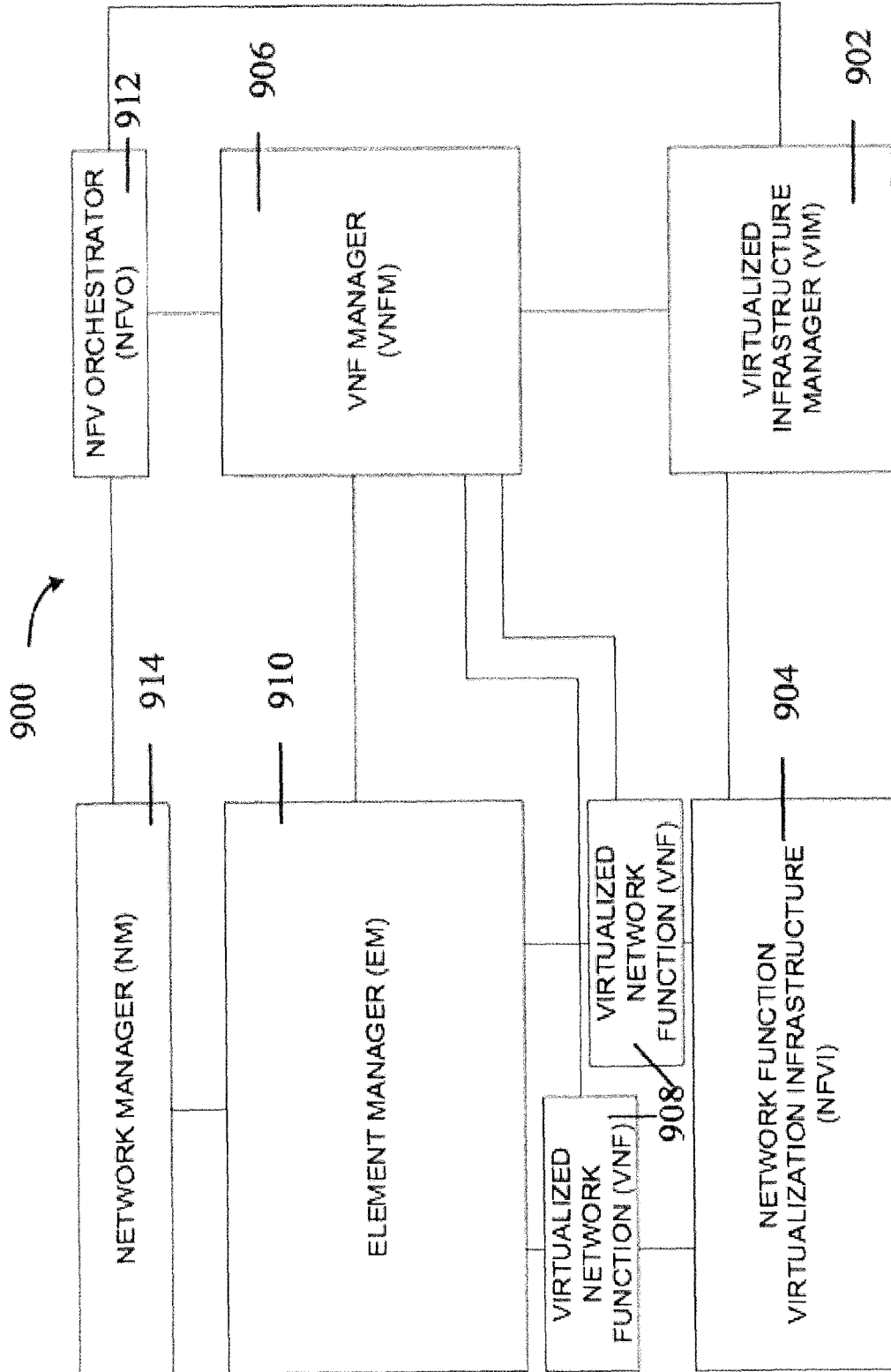

Fig. 9

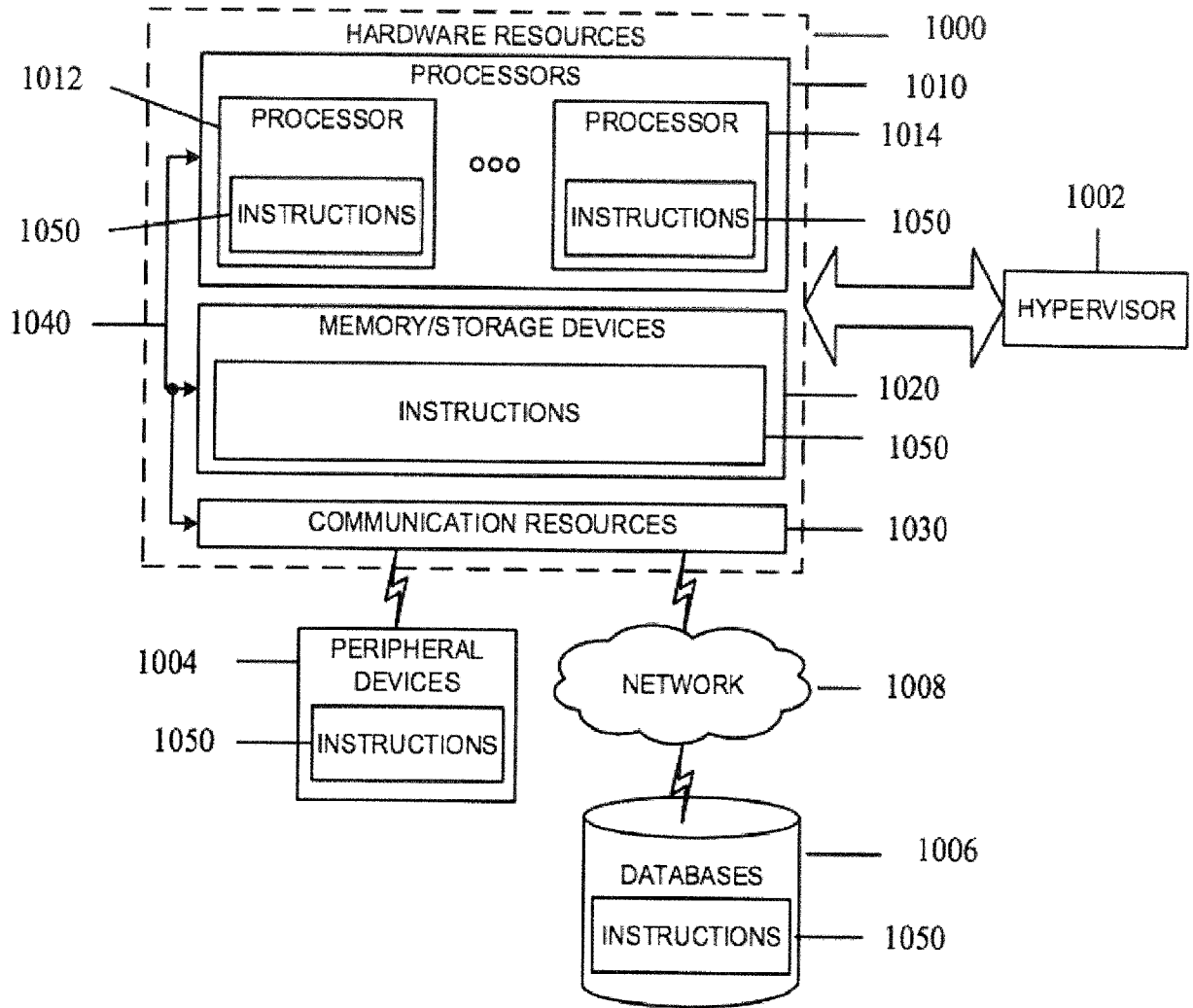

Fig. 10

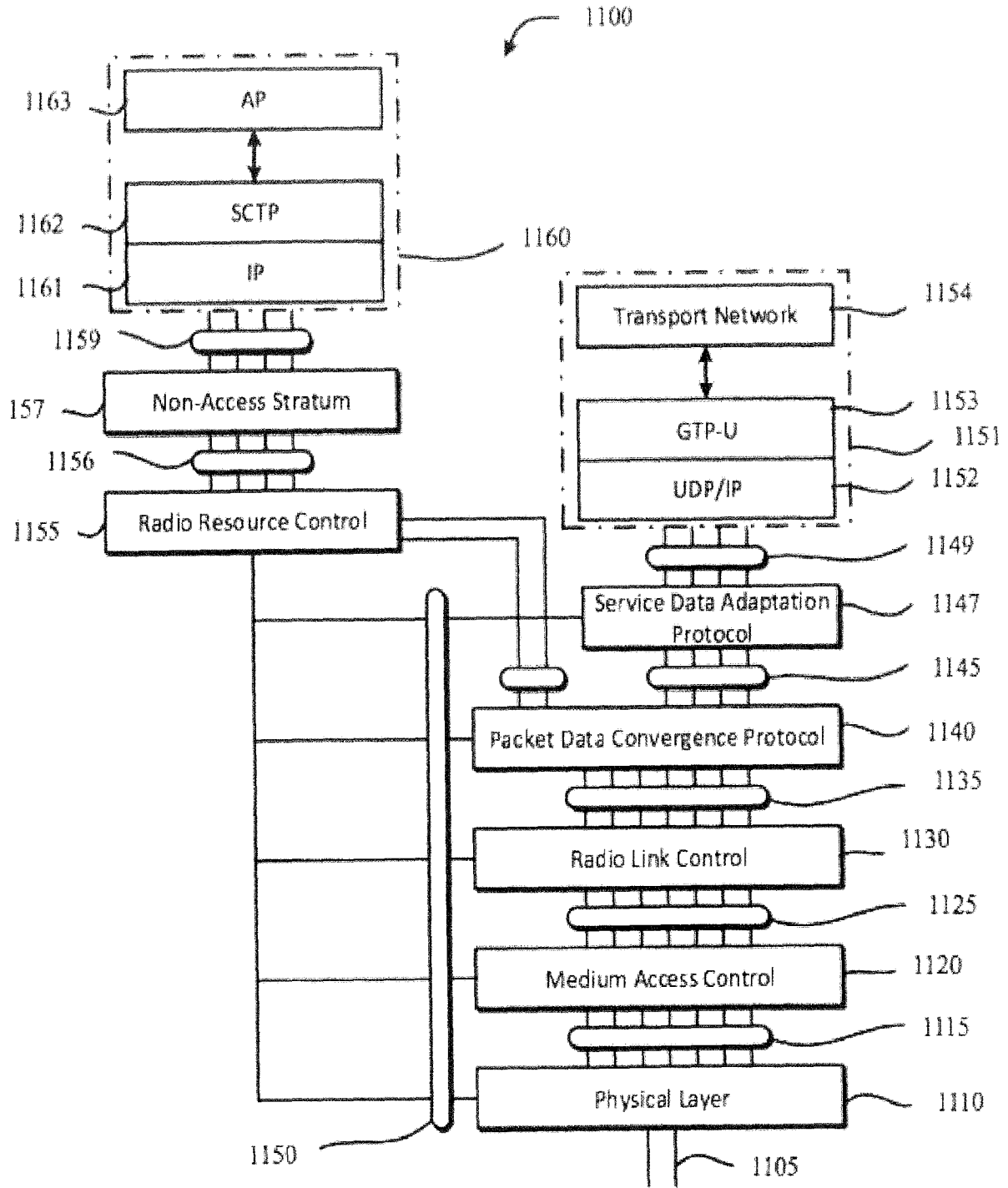

Fig. 11

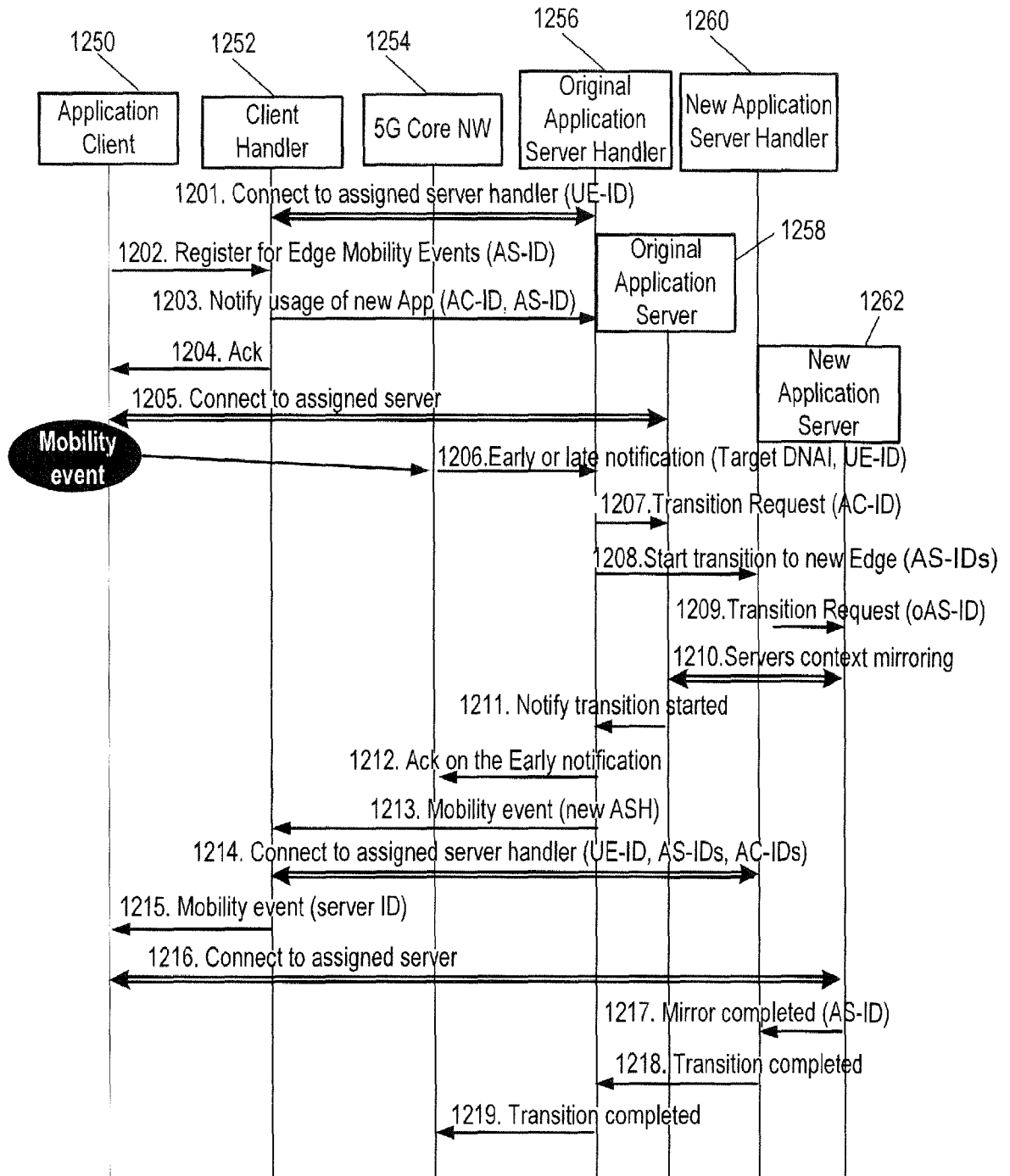

Fig. 12

INTERNATIONAL SEARCH REPORT

International application No PCT/US2020/030495

A. CLASSIFICATION OF SUBJECT MATTER INV. H04W4/50 H04W36/00 ADD.				
According to International Patent Classification (IPC) or to both national classification and IPC				
B. FIELDS SEARCHED				
Minimum documentation searched (classification system followed by classification symbols) H04W				
Documentation searched other than minimum documentation to the extent that such documents are included in the fields searched				
Electronic data base consulted during the international search (name of data base and, where practicable, search terms used) EPO-Internal, WPI Data				
C. DOCUMENTS CONSIDERED TO BE RELEVANT				
Category*	Citation of document, with indication, where appropriate, of the relevant passages	Relevant to claim No.		
X	WO 2018/041337 A1 (SONY MOBILE COMMUNICATIONS INC [JP]; SONY MOBILE COMM AB [SE]) 8 March 2018 (2018-03-08) page 1, line 1 - page 5, line 30 page 11, line 20 - page 18, line 4; figures 4,5 <div style="text-align: center; margin-top: 10px;"> ----- -/-- </div>	1-19		
<input checked="" type="checkbox"/> Further documents are listed in the continuation of Box C. <input checked="" type="checkbox"/> See patent family annex.				
* Special categories of cited documents : <table style="width: 100%; border: none;"> <tr> <td style="width: 50%; border: none; vertical-align: top;"> "A" document defining the general state of the art which is not considered to be of particular relevance "E" earlier application or patent but published on or after the international filing date "L" document which may throw doubts on priority claim(s) or which is cited to establish the publication date of another citation or other special reason (as specified) "O" document referring to an oral disclosure, use, exhibition or other means "P" document published prior to the international filing date but later than the priority date claimed </td> <td style="width: 50%; border: none; vertical-align: top;"> "T" later document published after the international filing date or priority date and not in conflict with the application but cited to understand the principle or theory underlying the invention "X" document of particular relevance; the claimed invention cannot be considered novel or cannot be considered to involve an inventive step when the document is taken alone "Y" document of particular relevance; the claimed invention cannot be considered to involve an inventive step when the document is combined with one or more other such documents, such combination being obvious to a person skilled in the art "&" document member of the same patent family </td> </tr> </table>			"A" document defining the general state of the art which is not considered to be of particular relevance "E" earlier application or patent but published on or after the international filing date "L" document which may throw doubts on priority claim(s) or which is cited to establish the publication date of another citation or other special reason (as specified) "O" document referring to an oral disclosure, use, exhibition or other means "P" document published prior to the international filing date but later than the priority date claimed	"T" later document published after the international filing date or priority date and not in conflict with the application but cited to understand the principle or theory underlying the invention "X" document of particular relevance; the claimed invention cannot be considered novel or cannot be considered to involve an inventive step when the document is taken alone "Y" document of particular relevance; the claimed invention cannot be considered to involve an inventive step when the document is combined with one or more other such documents, such combination being obvious to a person skilled in the art "&" document member of the same patent family
"A" document defining the general state of the art which is not considered to be of particular relevance "E" earlier application or patent but published on or after the international filing date "L" document which may throw doubts on priority claim(s) or which is cited to establish the publication date of another citation or other special reason (as specified) "O" document referring to an oral disclosure, use, exhibition or other means "P" document published prior to the international filing date but later than the priority date claimed	"T" later document published after the international filing date or priority date and not in conflict with the application but cited to understand the principle or theory underlying the invention "X" document of particular relevance; the claimed invention cannot be considered novel or cannot be considered to involve an inventive step when the document is taken alone "Y" document of particular relevance; the claimed invention cannot be considered to involve an inventive step when the document is combined with one or more other such documents, such combination being obvious to a person skilled in the art "&" document member of the same patent family			
Date of the actual completion of the international search 30 June 2020		Date of mailing of the international search report 15/09/2020		
Name and mailing address of the ISA/ European Patent Office, P.B. 5818 Patentlaan 2 NL - 2280 HV Rijswijk Tel. (+31-70) 340-2040, Fax: (+31-70) 340-3016		Authorized officer Wuillème, Cédric		

INTERNATIONAL SEARCH REPORT

International application No
PCT/US2020/030495

C(Continuation). DOCUMENTS CONSIDERED TO BE RELEVANT

Category*	Citation of document, with indication, where appropriate, of the relevant passages	Relevant to claim No.
A	<p>HUAWEI ET AL: "Support new services such as Routing optimization when server changes", 3GPP DRAFT; S1-152437 WAS 2098 USE CASE FOR OPTIMIZING ROUTING PATH WHEN SERVER CHANGES-R6, 3RD GENERATION PARTNERSHIP PROJECT (3GPP), MOBILE COMPETENCE CENTRE ; 650, ROUTE DES LUCIOLES ; F-06921 SOPH , vol. SA WG1, no. Belgrade, Serbia; 20150817 - 20150821 24 August 2015 (2015-08-24), XP051033575, Retrieved from the Internet: URL:http://www.3gpp.org/ftp/tsg_sa/WG1_Ser v/TSGS1_71_Belgrade/Docs/ [retrieved on 2015-08-24] the whole document</p>	1-19
A	<p>----- HUAWEI INTEL: "Discussion on SA2 Edge computing study", 3GPP DRAFT; S2-1901832 DISCUSSION ON ENHANCEMENT OF SUPPORT FOR EC IN 5GC V1.5, 3RD GENERATION PARTNERSHIP PROJECT (3GPP), MOBILE COMPETENCE CENTRE ; 650, ROUTE DES LUCIOLES ; F-06921 SOPHIA-ANTIPOLIS , 19 February 2019 (2019-02-19), XP051610423, Retrieved from the Internet: URL:http://www.3gpp.org/ftp/tsg%5Fsa/WG2%5FArch/TSGS2%5F131%5FTenerife/Docs/S2%2D1901832%2Ezip [retrieved on 2019-02-19] page 7 - page 7</p> <p>-----</p>	1-19

INTERNATIONAL SEARCH REPORT

Information on patent family members

International application No
PCT/US2020/030495

Patent document cited in search report	Publication date	Patent family member(s)	Publication date
WO 2018041337 A1	08-03-2018	CN 109691147 A	26-04-2019
		EP 3508002 A1	10-07-2019
		US 2019191341 A1	20-06-2019
		WO 2018041337 A1	08-03-2018
