

No. 659,668.

Patented Oct. 16, 1900.

A. E. HARTEL.
HYDROCARBON BURNER.

(Application filed July 3, 1900.)

(No Model.)

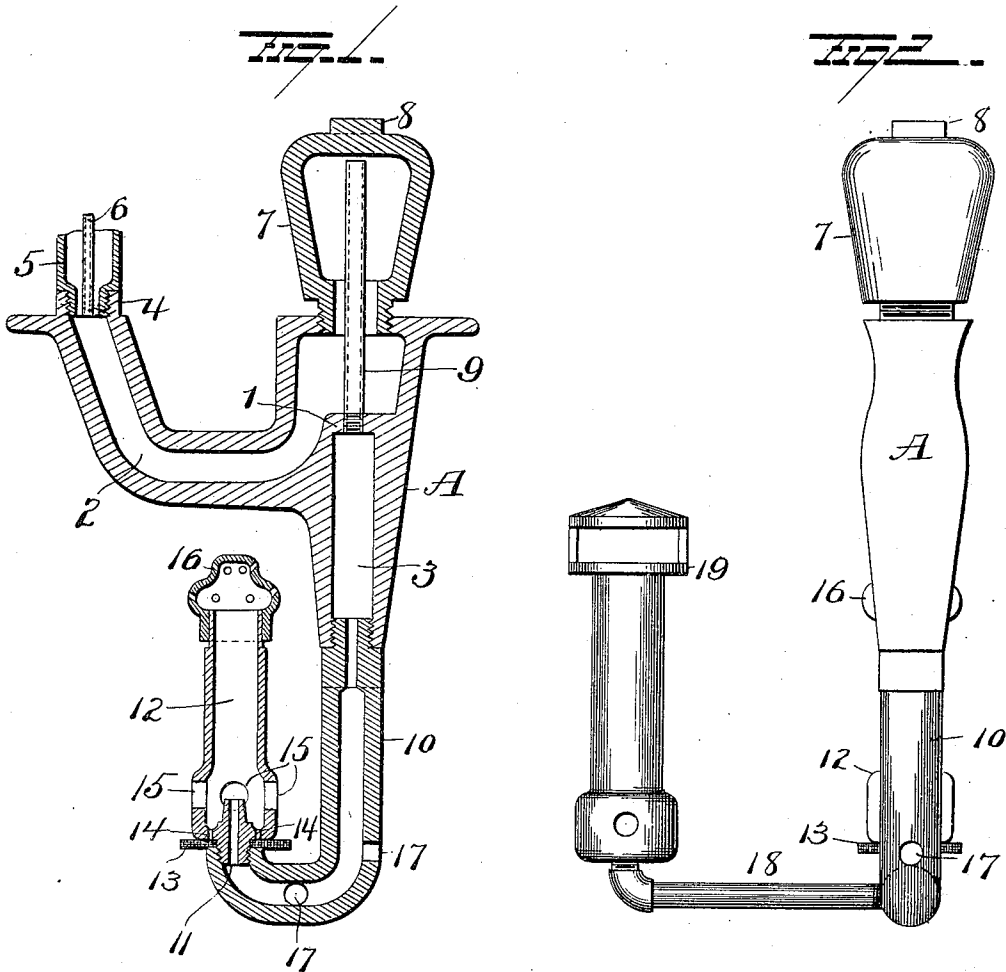

WITNESSES
E. D. Nottingham
G. J. Downing

INVENTOR
A. E. Hartel
By H. A. Seymour
Attorney

UNITED STATES PATENT OFFICE.

ALBERT E. HARTEL, OF PHILADELPHIA, PENNSYLVANIA, ASSIGNOR OF TWO-THIRDS TO GORDON H. MULLIN AND PERCY B. METZGER, OF SAME PLACE.

HYDROCARBON-BURNER.

SPECIFICATION forming part of Letters Patent No. 659,668, dated October 16, 1900.

Application filed July 3, 1900. Serial No. 22,443. (No model.)

To all whom it may concern:

Be it known that I, ALBERT E. HARTEL, a resident of Philadelphia, in the county of Philadelphia and State of Pennsylvania, have invented certain new and useful Improvements in Hydrocarbon - Burners; and I do hereby declare the following to be a full, clear, and exact description of the invention, such as will enable others skilled in the art to which it appertains to make and use the same.

My invention relates to an improvement in hydrocarbon-burners, one object of the invention being to provide a device of the above-mentioned character which will preclude any possibility of unvaporized hydrocarbon passing to the burner.

A further object is to provide an improved hydrocarbon-burner which will prevent the transmission of heat to the hydrocarbon-supply.

A further object is to provide improved means for starting vaporization in the retort or vaporizer.

With these objects in view the invention consists in certain novel features of construction and combinations and arrangements of parts, as will be more fully hereinafter described, and pointed out in the claims.

In the accompanying drawings, Figure 1 is a view in section illustrating my improvements, and Fig. 2 is a view in elevation taken at right angles to Fig. 1.

A represents a casting provided internally with a partition 1, forming two compartments—namely, the vaporizing chamber or retort 2 and a chamber 3, to which the vapor is supplied. The vaporizing chamber or retort 2 is approximately U-shape in side view and is provided at its inlet end with an internally-screw-threaded collar 4, into which is screwed the end of an air-supply pipe 5, inclosing or surrounding the hydrocarbon-supply pipe 6. The other end of the vaporizing-chamber is made with a threaded hole, into which is screwed the threaded contracted end of an inverted conical dome 7, which latter is provided on its top with an angular enlargement 8 for the reception of a wrench to facilitate screwing the same into proper position.

A pipe 9 is screwed into an opening in the

partition 1, so as to communicate with the chamber 3, and extends up through the contracted lower end of dome 7 and terminates near the top thereof.

A pipe 10 is screwed into the lower end of chamber 3 and is curved at its lower end and internally screw-threaded, into which is screwed a nipple 11 on the lower end of a commingling-chamber 12, said nipple having a contracted opening therein to permit but the proper flow of vapor into the commingling-chamber, and an asbestos disk 13 is held in position at the bottom of the commingling-chamber by the latter being screwed down onto the pipe 10, and perforations 14 are made in the bottom of the commingling-chamber to permit the passage of oil therethrough to the disk to saturate the latter for preliminary heating of the vaporizing-chamber, as will be more fully hereinafter explained.

Air-inlet openings 15 are provided in the side walls of the commingling-chamber near its lower end, for the admission of air to be mixed with the vapor and be burned at the burner 16, screwed onto the upper end of the commingling-chamber to direct the flame against the vaporizing chamber or retort.

The pipe 10 is provided in its rear and side walls with openings 17, adapted to communicate with vapor-pipes 18 for supplying vapor to additional burners 19, one of which latter is shown in Fig. 2.

The operation of my improvements is as follows: To start the burner, oil is poured through the openings 15 in the commingling-chamber 12 and will pass through perforations 14 and saturate the asbestos disk 13, which latter is ignited, and the flame will pass up through the perforations 14 and burner 16 and around the outside of the commingling-chamber 12 to heat the vaporizing chamber or retort 2, into which hydrocarbon is supplied by pipe 6 and air under pressure by pipe 5, and the heat of the burning oil on the disk 13 will vaporize the hydrocarbon in the retort 2 and the same will pass up into dome 7 and down through pipe 9, chamber 3, pipe 10, and into the commingling-chamber 12, where it will be thoroughly mixed with air entering through openings 15 and the mixed air and vapor fed to the burner 16, which

will be ignited by the flame from the burning-disk 13 and the operation of vaporization maintained by the burner 16 after the flame from the disk has been extinguished. The
5 vapor will also be supplied to the pipes 18 and burners 19, as heretofore explained.

It will be seen that by employing the dome 7 any possibility of hydrocarbon unvaporized passing through pipe 9 is prevented, as the
10 contracted lower end of the dome serves as a shield to stop the passage of hydrocarbon into the dome, and even though a very small quantity should escape through the contracted end of the dome the inverted conical
15 shape of the interior of the latter will direct the same back into the retort and absolutely prevent its entrance into pipe 9, and it will also be seen that by inclosing the hydrocarbon-inlet pipe 6 in the air-supply pipe 5 the
20 former is always surrounded by a current of air and the heat of the retort cannot be communicated thereto. Hence the danger of overheating the hydrocarbon-supply is entirely obviated.

25 Various slight changes might be resorted to in the general form and arrangement of the several parts described without departing from the spirit and scope of my invention, and hence I would have it understood that I
30 do not wish to limit myself to the precise details set forth, but consider myself at liberty to make such slight changes and alterations as fairly fall within the spirit and scope of my invention.

35 Having fully described my invention, what I claim as new, and desire to secure by Letters Patent, is—

1. A hydrocarbon-burner comprising a retort, a dome supported upon and communicating therewith by a contracted opening, a
40 vapor-pipe communicating with the upper portion of the dome, a burner under the retort and means for conducting vapor from said vapor-pipe to the burner.

45 2. A hydrocarbon-burner comprising a retort, a dome in communication therewith, a vapor-pipe communicating with the upper portion of said dome, and a burner arranged to discharge against said retort, said dome be-

ing situated in the path of the products of 50 combustion from the burner.

3. A hydrocarbon-burner comprising a retort, a dome in communication therewith, a vapor-pipe communicating with the upper portion of said dome, and a burner arranged
55 to discharge in the direction of the retort and the dome, said retort being situated between the burner and the dome.

4. A hydrocarbon-burner, comprising a retort, a dome located over and communicating
60 therewith by a contracted opening and a vapor-pipe communicating with the upper portion of the dome and passing through said contracted opening and the retort.

5. In a hydrocarbon-burner, the combination 65 with a retort, of a hydrocarbon-supply pipe communicating with said retort and inclosed in an air-supply pipe, an inverted conical dome communicating with the retort, a vapor-pipe communicating with the upper
70 portion of the dome and passing through the retort and adapted to supply vapor to a burner for heating the retort.

6. A hydrocarbon-burner, comprising a casting, a partition therein forming a vaporizing-chamber and an outlet-chamber for vapor, a dome communicating with the vaporizing-chamber and a pipe passing through the vapor-outlet chamber and connecting the
80 vapor-outlet chamber with the upper portion of the dome.

7. In a hydrocarbon-burner, the combination with a retort and a pipe communicating therewith, of a commingling-chamber screwed
85 into said pipe, a disk of incombustible fibrous material held between the commingling-chamber and pipe, and the commingling-chamber provided with perforations through which oil is poured to saturate the disk, which latter, when ignited, is adapted to heat the retort
90 and start vaporization therein.

In testimony whereof I have signed this specification in the presence of two subscribing witnesses.

ALBERT E. HARTEL.

Witnesses:

S. W. FOSTER,
R. S. FERGUSON.