



INTERNATIONAL APPLICATION PUBLISHED UNDER THE PATENT COOPERATION TREATY (PCT)

(51) International Patent Classification ⁵ : G09B 19/00	A1	(11) International Publication Number: WO 96/00432 (43) International Publication Date: 4 January 1996 (04.01.96)
(21) International Application Number: PCT/US94/07214 (22) International Filing Date: 27 June 1994 (27.06.94) (71) Applicant: SEKIGUCHI, Yoshi [JP/US]; 437 Marshman, Highland Park, IL 60035 (US). (74) Agent: TOLPIN, Thomas, W.; 444 Dell Lane, Highland Park, IL 60035 (US).	(81) Designated States: AU, BR, CA, CN, JP, KR, European patent (AT, BE, CH, DE, DK, ES, FR, GB, GR, IE, IT, LU, MC, NL, PT, SE). Published <i>With international search report.</i>	

(54) Title: PROCESS AND DISPLAY WITH MOVEABLE IMAGES

(57) Abstract

An efficient economical process is provided to produce an intricate impressive display (12), (1200) with outstanding marketing and advertising appeal. In the process, multiple images (420), (422), (1218) are formed, such as on a central processing unit (200), the images are masked and striped (300), and portions thereof are superimposed. The superimposed masked images can be printed on an underlying back or rearward web (1214). Transparent rods (900), a plate lens, a cluster of anamorphic lenses (800), or a grid (160), (1414), can be placed in front of the back web to provide a special display which has the illusion of animation as the angle of sight changes. The special display can be used to provide an attractive container (1010), cup, glass, mug (1060), bottle, package, box (500), lampshade (1110), magazine (1210), comic book, paper back book, hard bound book (1552), cover (502), page, envelope (1202), greeting card (1302), compact disc case (1412), laser disc case (1502), brochure, or pamphlet.

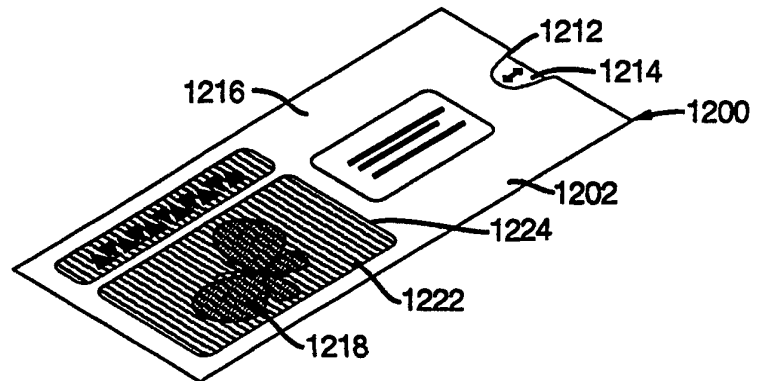

FOR THE PURPOSES OF INFORMATION ONLY

Codes used to identify States party to the PCT on the front pages of pamphlets publishing international applications under the PCT.

AT	Austria	GB	United Kingdom	MR	Mauritania
AU	Australia	GE	Georgia	MW	Malawi
BB	Barbados	GN	Guinea	NE	Niger
BE	Belgium	GR	Greece	NL	Netherlands
BF	Burkina Faso	HU	Hungary	NO	Norway
BG	Bulgaria	IE	Ireland	NZ	New Zealand
BJ	Benin	IT	Italy	PL	Poland
BR	Brazil	JP	Japan	PT	Portugal
BY	Belarus	KE	Kenya	RO	Romania
CA	Canada	KG	Kyrgystan	RU	Russian Federation
CF	Central African Republic	KP	Democratic People's Republic of Korea	SD	Sudan
CG	Congo	KR	Republic of Korea	SE	Sweden
CH	Switzerland	KZ	Kazakhstan	SI	Slovenia
CI	Côte d'Ivoire	LI	Liechtenstein	SK	Slovakia
CM	Cameroon	LK	Sri Lanka	SN	Senegal
CN	China	LU	Luxembourg	TD	Chad
CS	Czechoslovakia	LV	Latvia	TG	Togo
CZ	Czech Republic	MC	Monaco	TJ	Tajikistan
DE	Germany	MD	Republic of Moldova	TT	Trinidad and Tobago
DK	Denmark	MG	Madagascar	UA	Ukraine
ES	Spain	ML	Mali	US	United States of America
FI	Finland	MN	Mongolia	UZ	Uzbekistan
FR	France			VN	Viet Nam
GA	Gabon				

PROCESS AND DISPLAY WITH MOVEABLE IMAGES**BACKGROUND OF THE INVENTION**

This invention pertains to displays and, more particularly, to advertising and educational displays.

5 Conventional print advertising and packaging is accomplished by printing stationary non-moveable information and pictures on magazines, newspapers, brochures, flyers, posters, billboards, signs, wrapper, boxes, etc. While many conventional print advertisement
10 and packages (trade dress) are interesting, most are not. A primary purpose of a good advertisement and trade dress (package) is to attract the attention of the reader (customer) and convey the desired information. Unfortunately, many print advertisements and packages do
15 not attract the attention of customers.

In an effort to attract the customer's attention, various types of electrical signs have been installed, such as illuminated signs, including neon signs, billboard illuminated with flood lights and spot lights, marquees
20 with moving messages, blinking lights, etc. Electrical signs, however, are often very costly, bulky, and difficult to repair. Electrical signs are also not practical for packages, magazines, newspapers, etc. nor for educational games for small children.

25 Over the years, many types of toys and gadgets have been developed or suggested with moveable, non-electrical powered pictures, such as: kaleidoscopes, zoetropes, praxinoscopes, kinetoscopes, viewmaster devices with rotating discs, manual and crankable flip cards, laminated
30 plastic keychains, and sheets with moveable overlays to illustrate rotating wheels and smoke billowing from locomotives. Many of the toys and gadgets are interesting but are not useful in billboards, signs, educational games, wrappers, boxes and other packages.

35 It is, therefore, desirable to provide an improved display which overcomes most, if not all, of the preceding problems.

SUMMARY OF THE INVENTION

An improved process is provided for producing an attractive, aesthetic display with superb marketing and advertising appeal. Advantageously, the novel process is efficient, effective, and economical. Desirably, the high quality display is easy-to-use, impressive to view and pleasing to see and readily and accurately conveys the information being displayed. The display can also feature moveable messages and high quality images which move without the need and cost of expensive electrical equipment.

To this end, the process comprises generating at least two images (objects) with a computer or other central processing unit (CPU). The first image can be produced either creating original illustration/design or other graphic elements or by optically scanning or electronically reading the desired image (indicia) from a photograph, magazine, brochure, document, or other media and transmitting the image to a monitor or display screen of the CPU. The second image can be generated by electronically copying and subsequently altering and modifying the first image on the monitor. At least one and preferably all the images are then masked, electrically revised and striped on the CPU by electronically removing erasing, canceling, or otherwise deleting a symmetrical pattern of spaces on the images to form masked images with a spaced array of stripes comprising viewable opaque portions with spaces positioned between and separating the stripes.

After masking, part or all of the portions of the masked images are overlaid, superimposed, and combined upon each other in offset relationship so that the viewable stripes of one image are positioned in the spaces (spacer portions) of another image. The superimposed images or illustrations are printed on an underlying web or rearward web, such as on coated backing paper. If desired, the web can be made of other materials, such as wood, metal, glass,

composites, paper, paperboard, or cardboard, preferably or substantially planar or flat, flexible sheets.

The images also can be printed in black and white or in different colors, if desired. The images can be words, letters, photographs, pictures, portraits, or be of different configurations and designs and can have indicia thereon, if desired.

A set, series, or array of transparent rods, a plate lens, or a cluster of lenses, preferably anamorphic lenses, can be spaced in front of the superimposed images of the rearward web so that only one of the images can be viewed from one angle of observation and a different image can be viewed from other angles of observation. The angles of observation can be changed if the observer moves, if the rearward web moves, or upon moving the transparent rods or lens(es). The space between the rearward web and the lens(es) or transparent rods can be empty (void) or occupied with transparent material or spacers. One or both sides or surfaces of each lens or transparent rod can be convex, concave, curved, conical, rectangular, cylindrical, planar, or flat. Lines or bars can also be etched or otherwise placed upon each lens or transparent rods. These lines or bars can be horizontal, vertical, diagonal, angular, curved, parallel, skewed, radiant or radial from points within or outside the lens or rod. The lens(es) and rods magnify the images and provide animation and the appearance of movement of the images to the observer as the observer's angle of sight changes.

A grid or grid-like pattern or sleeve can also be placed in front of the superimposed images of the rearward web in lieu of or along with the lens(es) or transparent rods. The grid can be printed on a front web, preferably initially on a plastic sheet of film, to provide an overlay (grid overlay), mask, and screen. The grid has a special arrangement of transparent void spaces which provide a series of windows to view one of the viewable portions of one of the images while the other images are blocked from

view by opaque bars (rules) between the windows. One or both of the webs can be moved in a longitudinal, lateral, lateral, and/or arcuate direction or can pivot. The stripes of the images can have a lesser or greater spacing or thickness than the bars of the grid to attain reverse or concurrent movement in the direction of the front web (grid) or underlying (back) web.

The rearward web can also be stationary, such as for use in a sign or billboard. The sign or billboard has a frame surrounding and secured to the webs and posts, columns, stands, hooks or wall fasteners to elevate the frame above the floor or ground. Desirably, the images change or move in the sign when the observer moves.

The display can also be in the form of an educational game and toy with a housing to peripherally enclose a stationary front webs (grid). The rearward web can comprise a scroll connected to cylindrical roller which are rotated by knobs, cranks, handles, or other manually grippable controls. The game can further be constructed to receive interchangeable cassette or cartridges containing one or both of the webs and different images thereon. The images change or move when the scroll is rotated clockwise or counterclockwise. In some circumstances, it may also be desirable to have an educational game and toy with a moveable front web.

The display can also be in the form of a package, such as for a candy bar wrapper, box of candy or carton. The novel package has a cover which comprises a transparent outer sleeve. The transparent sleeve partially encloses and slides upon the wrapper or box. In the package, the top of the wrapper or box comprises the rearward web. The top of the cover comprises the front web. When the cover is slid off or moved along the box or wrapper, the images change or move.

The display can further comprise a rotatable display or book with a stationary front web having a radial grid and a rotatable disc or wheel providing a rotatable

rearward web with radial superimposed images thereon. In some circumstances, it may be desirable that the front web comprise a rotatable disc or wheel while the rearward web can be stationary or also rotate.

5 The display can also be in the form of a container assembly. The container assembly can comprise a display container, such as a cup, glass, mug, or bottle. The container comprises the rearward web with superimposed (combined) images thereon. The container assembly has a
10 cover which comprises a transparent outer sleeve. The transparent sleeve partially encloses, slides and rotates upon the container. When the sleeve is rotated, slid or moved along the container, the images change or move. If desired, the sleeve can comprise stationary transparent
15 outer shell (cup) providing a grid, such as for a thermal mug. Furthermore, the sleeve can comprise stationary lenses or rods which magnify the images of the container and provide animation and the appearance of movement of the images to the observer as the observer's angle of sight
20 changes.

 The container assembly can also comprise a bottle with superimposed images on the backside and a grid on the front side. When water or other transparent liquid is placed in the bottle to a height above the images, the liquid
25 functions as a lens to magnify the images.

 The display can also comprise an information display for use as part of the cover or inside of a book, magazine, pamphlet, brochure, greeting card, envelope, compact disc cover (packaging), laser disc cover (packaging), or game.
30 The information display provides an assembly with a pocket having a transparent outer sleeve comprising a grid. The transparent sleeve covers the front web with superimposed (combined) images thereon. The transparent web can be stationary and the sleeve can moveable so that it can be
35 pulled, rotated or otherwise slide in the pocket. When the web slides or moves along the pocket, the images on the information display change or move. If desired, the web

can be stationary and the sleeve can move. Also, lenses or rods can be used in lieu of the grid. Pop up grids for greeting cards can also be used.

The display can further be in the form of a lampshade assembly. The lampshade assembly can have a truncated, frustroconical, or cylindrically shaped lampshade and has a cover which comprises a transparent outer sleeve. The lampshade comprises the rearward web. The transparent sleeve can partially enclose, slide and rotates upon the lampshade. The sleeve provides a grid which comprises the front web. When the sleeve is rotated, slid or moved along the lampshade, the images change or move. If desired, the sleeve can comprise stationary transparent rods or lenses as described above. The lenses and rods magnify the images of the lampshade and provide animation and the appearance of movement of the images to the observer as the observer's angle of sight changes.

The display also can be used in or form part of other articles of manufacture and are useful to display advertising, marketing, promotional, educational, government, and safety material, messages, and other information.

As used in this Patent Application, the term "striping" means forming an image with substantially parallel stripes.

The term "striped" as used in this Patent Application, means an image comprising substantially parallel stripes, radial stripes, or dotted lines.

The term "superimposed" as used in this Patent Application, means that portions of the images are combined and placed upon each other.

The terms "image" and "images" as used in this Patent Application mean printed, painted, or written information, photographs, pictures, illustrations, designs, symbols, objects, words, and/or letters.

A more detailed explanation of the invention is provided in the following description and claims taken in

conjunction with the accompanying drawings.

BRIEF DESCRIPTION OF THE DRAWINGS

Figure 1 is a perspective view of a central processing unit and optical scanner for producing a display in accordance with principles of the present invention;

Figure 2 is a perspective view of a display sign;

Figure 3 is a front view of the rearward web, providing a backing sheet with underlying images, of the display sign;

Figure 4 is a front view of the front web (overlay) of the displays sign;

Figure 5 is a front view of the display sign, with the front web placed in front of the rearward web, and illustrating the first image;

Figure 6 is a front view of the display sign, with the front web placed in front of the rearward web, and illustrating the second image;

Figure 7 is a masked image (object) of an A;

Figure 8 is a masked image (object) of a B;

Figure 9 illustrates superimposed (combined) masked images A and B;

Figure 10 illustrates a grid placed over the superimposed (combined) masked images A and B so as to only display the first image comprising the letter A;

Figure 11 illustrates the grid moved by half of one grid (bar) unit over the superimposed masked images A and B;

Figure 12 illustrates the grid placed over the superimposed (combined) masked images A and B so as to only display the second image comprising the letter B;

Figure 13 is an image (object) of an A;

Figure 14 is a front view of a mask (grid);

Figure 15 is a masked image of an A produced by masking the grid of Figure 14 on the image of Figure 13;

Figure 16 is an image comprising a grid pattern;

Figure 17 is a mask of an outline (stencil) of the letter A;

Figure 18 is a masked image of an A produced by masking the mask of Figure 17 on the image of Figure 16;

Figure 19 illustrates two solid intermediate dolphin images;

5 Figure 20 illustrates two masked striped dolphin images;

Figure 21 illustrates two superimposed (combined) dolphin images;

10 Figure 22 illustrates a front web (overlay) comprising a radial grid;

Figure 23 illustrates the radial grid of Figure 22 placed over the superimposed (combined) dolphin images so as to only display the first image, and showing in dotted line part of the rear wheel comprising the rearward web;

15 Figure 24 illustrates the radial grid placed over the superimposed (combined) dolphin images so as to only display the second image, and showing in dotted line part of the rear wheel comprising the rearward web;

20 Figure 25 is a perspective view of a wrapper of a composite candy bar display package in accordance with principles of the present invention;

Figure 26 is a perspective view of a cover of the composite candy bar display package:

25 Figure 27 is a perspective view of the composite candy bar display package with the cover about the wrapper so as to only display the first image;

Figure 28 is a perspective view of the composite candy bar display package with the cover about the wrapper so as to only display the second image;

30 Figures 29 and 30 illustrate images appearing to move in the same and opposite directions as the underlying rearward web;

Figures 31-33 illustrate a three image display;

Figures 34-37 illustrate a four image display;

35 Figure 38 is a perspective view of an educational display game with the underlying web positioned to only display the first images;

Figure 39 is a perspective view of the educational display game of Figure 38 with the underlying web positioned to only display the second images;

Figure 40 is a perspective view of an educational display game with a removable cassette;

Figure 41 is a perspective view of a lens positioned in front of an underlying web with superimposed images;

Figure 42 is an end view of transparent rods positioned in front of an underlying web with superimposed images;

Figure 43a is a perspective view of a cup with superimposed (combined) butterfly images;

Figure 43b is a perspective view of a sleeve, which provides a grid that slides over and rotates upon the cup of Figure 43a;

Figure 43c is a perspective view of a container assembly with the sleeve of Figure 43b slid over the cup of Figure 43a so as to display only one of the images;

Figure 43d is a perspective view of a container assembly similar to Figure 43c but with the sleeve rotated so as to only display another of the images;

Figure 44 is a perspective view of a thermal cup container assembly comprising an inner cup (core) with superimposed (combined) butterfly images and an outer transparent cup (shell) with a grid thereon;

Figure 45 is a perspective view of another container assembly comprising an inner cup with superimposed (combined) butterfly images and an outer lenticular lens placed over the images;

Figure 46 is a perspective view of a lampshade assembly comprising an inner lampshade with superimposed (combined) butterfly images and an outer grid thereon;

Figure 47 is a perspective view of a further container assembly comprising an empty bottle with superimposed (combined) butterfly images on the back side wall and a grid on the opposite front side wall;

Figure 48 is a perspective view of the container

assembly of Figure 47 but with the bottle partially filled with a transparent liquid;

Figure 49 is a perspective view of an information display assembly comprising an envelope with a pocket having a rear web wall with superimposed (combined) butterfly images thereon and a front web wall comprising a slidable grid placed in a position so as to display only one of the images;

Figure 50 is a perspective view of the information display assembly of Figure 49 but with the grid pulled slightly to the right to display a different one of the images;

Figure 51 is a perspective view of another information display assembly comprising a cover or interior page of a magazine or book with a pocket having a rear wall with superimposed (combined) butterfly images thereon and a front wall comprising a slidable grid placed in a position so as to display only one of the images;

Figure 52 is a perspective view of the information display assembly of Figure 51 but with the grid pulled slightly to the right to display a different one of the images;

Figure 53 is a perspective view of a further information display assembly comprising a cover or interior page of a magazine or book having a rear web wall with superimposed (combined) butterfly images thereon and a front web wall comprising a lenticular lens viewed from one angle of view so as to display only one of the images;

Figure 54 is a perspective view of the information display assembly of Figure 53 but viewed from a different angle of view so as to display a different one of the images;

Figure 55 is a perspective view of still another information display assembly comprising a greeting card having a rear web wall with superimposed (combined) butterfly images thereon and a pop up front web wall comprising a grid viewed from one angle of view so as to

display only one of the images;

Figure 56 is a perspective view of the information display assembly of Figure 55 but viewed from a different angle of view so as to display a different one of the
5 images;

Figure 57 is a perspective view of a further information display assembly comprising a greeting card having a rear web wall with superimposed (combined) butterfly images thereon and a front web wall comprising a
10 grid having its left edge glued or otherwise fastened to the facing page (back of the cover) and with the grid in a position so as to display only one of the images;

Figure 58 is a perspective view of information display assembly of Figure 57 but with the grid pulled slightly to
15 the left to display a different one of the images;

Figure 59 is an assembly perspective view of an information display assembly comprising a display card for a compact disc case providing a rear wall with superimposed (combined) butterfly images thereon and an outer cover for
20 the compact disc having a front wall comprising a grid;

Figure 60 is a perspective view of information display assembly of Figure 59 but with the display card inserted inside the cover and the grid positioned at an angle of view to display only one of the images;

Figure 61 is a perspective view of still another information display assembly comprising a rotatable display card for a laser disc, game or advertising brochure providing a rear wall with superimposed (combined) butterfly images thereon and a pocket with outer cover
30 providing a front wall having an arcuate window comprising a grid displaying only one of the images;

Figure 62 is a perspective view of information display assembly of Figure 61 but with the display card rotated to a different position so as to display another one of the
35 images;

Figure 63 is a perspective view of a further information display book assembly comprising a rotatable

cover and pages (rearward web) with superimposed (combined) images thereon and a rotatable arcuate front web wall comprising a grid placed in a position to display some of the images on the cover and pages;

5 Figure 64 is a perspective view of information display assembly of Figure 61 but with the grid rotated to a different position so as to display some of the other images on the cover and pages.

DETAILED DESCRIPTION OF THE PREFERRED EMBODIMENTS

10 An efficient accurate timesaving process is provided to produce an attractive quality display 100-118 of Figures 2-40 with moveable images 120-154 providing a graphic display device and assembly comprising moveable pictures, words, letters, symbols, designs, or other indicia or
15 information. In the process an overlying grid-like pattern 160-176 providing a grid and at least two images 120-154, including intermediate, unscreened, unmasked, non-striped (unstriped), substantially solid images, generated, electrically created, produced, and formed on a central
20 processing unit (CPU) 200 (Figure 1) comprising a computer 202 and displayed, projected, and viewed on a monitor 204 comprising a screen of the central processing unit 200. The grids (grid-like patterns) and images illustrated in the drawings of this patent application, as well as other
25 grids and images, were generated on an Apple MacIntosh (Mac II) computer with Adobe Illustrator 88 1.9.3 software. Other computers and art and graphic software, such as Aldus FreeHand software, can be used, if desired.

30 The grid (grid-like pattern) 160-176 comprises a matrix and mask with a set, series, and array of aliquot evenly spaced, uniform, elongated opaque bars 300-316 comprising stripes or rules and a set, series, and array of aliquot, evenly spaced, uniform slit-like void spaces or
35 slits providing elongated windows 320-336 or striped slit-like port holes between the bars. Preferably, all the bars in a grid have the same thickness, are uniformly spaced from each other, and have a similar shape and size. The

bars can comprise radial bars 306 with radial portions that extend radially as shown in Figures 22-24, or can comprise curved bars with curved arcuate portions, or can comprise horizontal bars, diagonal bars, or preferably vertical bars 300-304 and 308-316 with parallel, straight vertical striped portions. Desirably, all the windows in a grid have a similar size and shape. The size, shape, and spacing of the grid can be modified by the operator or designer via the control keys (buttons) 206 (Figure 1) of the computer.

When the mask (grid) is generated on the CPU with an Adobe Illustrator 88 1.9.3 software program, the ends of the bars can be connected outside of the area which is used to mask and cover the underlying images; the mask appears in black and white when the program is in an artwork and template mode; and the mask appears transparent when the program is in the preview illustration mode, such as during masking and to preview superimposed (combined) images preparatory to printing.

The first intermediate, unscreened, unmasked, non-striped (unstriped), image can be created, originated, and generated by the designer on the computer 202 and monitor 204, or can be produced by initially optically scanning and electrically reading the desired image 400 on an optical scanner 208 (Figure 1) from a sheet of paper 402, such as from a magazine, newspaper, brochure, etc. During testing, numerous images were scanned on a Dest PC Scan Plus scanner with Publish Pac 1.11 scanning software. Other types of scanners and software scanning programs can be used, if desired.

The scanned image 400 (Figure 1) is transmitted to the monitor 204 via a cable wire 210 and moved to a position on the screen 204 away from the grid. The first intermediate image can be enlarged and reduced, expanded or contracted, in whole or in part, by the operator or designer via the computer control keys 206 of the CPU 200. The interior portions of the first intermediate image (pattern), which

can be bounded and enclosed by the periphery and outline of the image, can be generated and electrically painted in a selected solid color, such as with the Adobe Illustrator 88 1.9.3 software program, if desired, by the operator or
5 designer via the computer control keys 206 of the CPU 200.

The second image can be substantially or entirely different than the first image, such as the second image 124 of Figure 8. The second intermediate, unscreened, unmasked, non-striped (unstriped) image can be created,
10 originated generated, and produced, in whole or in part, in a manner similar to the method described above for the first intermediate image. Preferably, however, the second intermediate, unscreened, unmasked, non-striped is produced by electrically copying the first intermediate image, such
15 as the first intermediate, unscreened, unmasked, non-striped, solid dolphin image 404 of Figure 19, to form a copied, duplicate intermediate second image. The second intermediate image can be moved or otherwise placed on the screen 204 of the CPU 200 at a different location than the
20 first intermediate image or vice versa. In some circumstances, it may be desirable that the copied, unmasked, second intermediate image be identical to the first intermediate image and merely positioned at a different location or electrically painted in a different color. It
25 is usually preferred, however, to subsequently alter, revise, and modify at least a part of the overall design, appearance, and shape of the copied intermediate image until the desired intermediate image is attained, such as the revised, second intermediate, unmasked, unscreened,
30 non-striped, solid dolphin image 406 of Figure 19 with a raised tail and lowered fin, so that a substantial portion of the second intermediate image is different than the first intermediate image. This can be accomplished by the operator or designer via the computer control keys 206
35 (Figure 1) of the CPU 200.

Additional intermediate and final images, such as a third image 137 (Figure 33) and 141 (Figure 36), fourth

image 142 (Figure 37), etc., can be formed by following a sequence of steps similar to that described above for producing (generating) the second image.

In order to form the final, completed striped images, such as the striped image 123 of Figure 15, each of the intermediate images are electrically masked, screened, stenciled, and striped. This is accomplished by sequentially moving and overlaying the grid (mask) or duplicate grids, such as the grid 164 of Figure 14, on the intermediate images, such as the intermediate solid image 408 of Figure 13, and electrically deleting, erasing, and removing portions of the intermediate image behind the bars 304 (Figure 14) of the grid 164, via the computer control keys 206 (Figure 1) of the CPU 200. With the mask (grid) is generated on the CPU with Adobe Illustrator 88 1.9.3 software program, the grid is transparent in the preview illustration mode and need not be moved from the masked image. With other programs, it may be desirable that the grid be returned to its original location or moved to another location on the monitor of the CPU.

While the above method is preferred for best results, in some circumstances it may be desirable that the first intermediate image comprise stripes 410 (Figure 16), that the mask or grid comprise an outline, such or outline 412 (Figure 17), and that during masking, the exterior extraneous portions of the intermediate striped image 410 (Figure 16) located outside of the outline 412, be deleted to form the final striped image 423 (Figure 18).

Each of the completed striped, masked, screened final images has a set, series, and array of aliquot, evenly spaced, uniform stripes 421-454 comprising elongated viewable opaque portions or dotted lines and a set, series, and array of aliquot, evenly spaced, uniform spacer portion or spaces 460-466 between the stripes. Preferably, the stripes of all the images in each display are uniformly spaced from each other and have a similar size and shape. The stripes can comprise radial stripes, such as radial

stripes 426 and 427 (Figure 20) with radial portions that extend radially, as illustrated in the first and second striped, masked, screened, dolphin images 426 and 427 of Figure 20. The stripes can also comprise curved stripes or curved dotted lines, such as 421 and 422 of Figure 3, or stripes with curved portions, such as 431 and 432 of Figure 25. Furthermore, the stripes can comprise horizontal stripes, diagonal stripes, or preferable vertical stripes, such as 423 and 424 (Figures 7 and 8) with striped portions. Desirably, all the spacer portions between the stripes in an image are of a similar size and shape.

During masking, screening, and striping, the viewable stripes are positioned behind the windows of the grid and the spacer portions are obstructed and blocked from view behind the bars of the grid. The width of the strips (stripes) generally correspond to the width to the windows of the grid.

Preferably, the images are electrically formed, masked, and striped in accordance with the following formula:

$$B_w = O_w - I_1$$

wherein

B_w = width of the opaque bars of the grid or grid-like pattern;

O_w = overall combined width of the stripes of all the images;

I_1 = combined width of the stripes of the first image.

After masking and striping, the masked images are moved, superimposed, combined, and aligned in offset relationship to each other, via the computer control keys 206 (Figure 1) of the CPU 200 so that at least a portion of the stripes of the image are aligned in registration with and superimposed upon part of the spacer portions of the adjacent image(s) and vice versa, such as shown in superimposed images 120 (Figure 3), 125 (Figure 9), 128 (Figure 21), 130 (Figure 25), and 452 (Figures 39 and 39).

The grid can be printed on first elongated front web,

preferably a transparent plastic web comprising transparent semi-rigid shape-sustaining portions, to provide an overlay (overlay grid), screen, and mask. The superimposed images (illustrations) can be printed on a second elongated rearward back web, such as on an elongated paper web, a flexible plastic, or some other backing sheet, to provide the underlying illustrations and information. Printing can be accomplished with Linotronic model 300 printer and printed with four color separation on film as a negative or positive. Proofs can be developed with chromaline four piece laminated film or with progressive proofs bonded together or by short run proof printing, and subsequently printed on the desired paper, paperboard, plastic coated paper, or web. The print can be enlarged for billboards with a Mega Print printer. Other types of printers can be used.

The display comprises the front and rearward webs, which are preferably positioned parallel to each other. When the rearward web is placed behind the front web, the stripes of only one of the images can be viewed through the windows of the grid while the bars of the grid block and obstruct the view of the stripes of the other images, until one of the webs is moved or the observer changes positions and the stripes of another image become viewable through the windows of the grid, etc. creating the illusion of movement. The grid overlay is preferably at least as large as the moveable portions of the superimposed underlying images.

For best results for a two image display, the relationship of the width of the bars of the overlay (overlying) grid, the width of the stripes of the superimposed images, and the distance and spacing between the front web (overlay) and the rear web comprising the underlying images, to the focal point of the observer, are in accordance with the following formulas:

$$\begin{aligned} S &= B - D && \text{and} \\ A/B &= C/D \end{aligned}$$

- wherein S = the spacing (distance) between the front web (overlay) and the rearward web comprising the underlying images
- 5 B = the distance between the rearward web and the focal point (location) of the observer
- D = the distance between the front web (overlay) and the focal point (location) of the observer
- 10 A = maximum width of any stripe of the underlying superimposed images
- C = maximum width of any bar of the grid overlay

Therefore, if the overlay (front web) is placed against the rearward web, such as in the illustrated candy bar composite package of figures 27 and 28,, the maximum width of the bars of the grid should be equal to the maximum width of the stripes of the superimposed underlying images. If the overlay (front web) is spaced in front of the rearward web, such as in the illustrated display sign of Figure 2 and the educational display game of Figures 38-40, the maximum width of the bars of the grid can be smaller than the maximum width of the stripes of the superimposed underlying images, to accommodate perspective phenomena.

25 When the overlay (front web) is placed against the rearward web, each bar of the grid is at least as wide as a corresponding stripe of any image in the display. The bars of the grid are each wider than the corresponding stripes of the images in the display when more than two images are depicted in the display. For a two image display, i.e. a display with only two images, such as shown in Figures 7-12, each bar 302 of the grid 162 preferably has the same width as any one stripe 423 or 424 of the images 123 and 124. For a three image display, i.e. a display with only three images on a rearward web 477, such as shown in Figures 31-33, each bar 310 of the grid 170 has a width about equal to the combined width of two stripes of

the images 135-137. The three image display 108 of Figures 31-33 has a three step, 6 point rule with three point spaces. For a four image display 110, i.e. a display with only four images on a rearward web 479, such as shown in
5 Figures 34-37, each bar 312 of the grid 172 has a width about equal to the combined width of three stripes of the images 139-142, etc.

As shown in Figures 29 and 30, by varying (enlarging or decreasing) the spacing of the stripes of the images
10 relative to the bars of the grid and laterally moving the front web 480 and/or the rearward web 482, the images can appear to move concurrently in the same direction as the rearward web or the front web (grid) or countercurrent in the reverse direction of the rearward web or front web
15 (grid). For example, the 90 % image in the left of Figures 29 and 30 has vertical stripes which are smaller in width than the vertical bars of the 100 % grid so that the stripes of the left image appear to move in the same direction of the underlying rearward web 482 when the rearward web is moved laterally (sideways) in a direction
20 perpendicular or transverse to the vertical stripes and bar. The 110 % image on the right of Figures 29 and 30 has vertical stripes which are larger (broader) in width than the vertical bars of the 100 % grid so that the stripes of the right image appear to move in the same direction as the
25 rearward web 482 when the rearward web is moved laterally in a direction perpendicular and transverse to the vertical stripes and bars.

The composite display packaging 106 of Figures 27 and
30 28 comprises a package, box, carton, or flexible wrapper 500 (Figure 25) and a slidable open ended, tubular cover 502 (Figure 26). The package, box, carton, or wrapper 500 can be made of paper and coated with a glossy material, such as silicone. The wrapper 500 provides an inner
35 containment member and shell to wrap and enclose one or more items, such as a candy bar or pieces of candy. When folded and wrapped around the candy, the wrapper has an

elongated rectangular, top surface 504 (Figure 25), an elongated rectangular, bottom surface 506, rectangular sides 508 and 510, and rectangular ends 512 and 514. A semi-rigid box or carton can be used in lieu of the wrapper to enclose more candy or items, or to enclose larger items. The open ended tubular cover 502 can be made of flexible and semi-rigid transparent plastic, such as polyethylene or polypropylene. The cover 502 provide an outer sleeve which snugly fits around, peripherally encloses, and can laterally slide upon the top and bottom surfaces 504 and 506 and sides 508 and 510 of the inner containment member (wrapper) 500. The open ended outer sleeve 502 (Figure 26) has an elongated rectangular top 512, an elongated rectangular bottom (underside) 514, and rectangular sides 516 and 518.

The top 512 of the outer sleeve and cover 502 (Figure 26) provides a front web. The front web 502 has a grid-like pattern or grid 168 with vertical bars 308 (as view from above the top) and spaces providing transparent windows 328 between the bars 308. The sides 516 and 518 of the cover can optionally have upright bars and windows.

The top surface 504 of the inner containment member (wrapper) 500 (Figure 25) provides a rearward back web with superimposed images 130 thereon, including a first Good Stuff image 131 with vertical stripes 431 as viewed from above the top and a second Good Stuff image 132 with vertical stripes 432. The grid 168 (Figure 26) and images 130-132 are preferable made in the manner previously described. When the cover (sleeve) 502 is slid along the inner containment member (wrapper) 500, such as when the cover is being removed, to unwrap the wrapper, the images 131 and 132 have the illusion of moving. For example, in the first image 131 of Figure 27, the left O is down and the right O is up. In the second image 132 of Figure 28, the left O is up and the right O is down, so that the double OO has the appearance of googily eyes.

The rotatable display 104 of Figures 23 and 24 has a

stationary transparent plastic front web 520 and a rotatable disc or wheel 522 providing a rotatable rearward (back) web. The front web 520 (Figures 22-24) has a radial grid 166 with radial bars 306 and radial spaces providing transparent windows 326 between the bars 306. The rearward web 522 has superimposed dolphin images 128 (Figure 21). The superimposed images 128 can include a first radially striped, dolphin image 126 as shown in Figure 20 with radial stripes 426 and radial spaces 464 between the stripes 426 and a second radially striped, dolphin image 127 as shown in Figure 20, with radial stripes 427 and radial spaces 466 between the stripes. A substantial portion of the stripes 426 of the first image 126 are aligned in registration and positioned in spaces 466 of the second image 127, and a substantial portion of the stripes 427 of the second image 127 are aligned in registration and positioned in spaces 464 of the first image 126 in the superimposed image 128 of Figure 21. The grid and images are preferably made in the manner previously described. When the disc or wheel comprising the rearward web 522 (Figures 23 and 24) is rotated or pivoted, the images 126 and 127 have the illusion of moving. For example, in the first image 126 of Figure 23, the tail of the dolphin is pointed down and the front lower flipper is pointed rearwardly. In the second image 127 of Figure 24, the tail of the dolphin is moved upwardly and the front lower flipper is pointed downwardly.

The advertising display sign 100 of Figure 2 comprises a sign assembly and billboard 600 with a rectangular frame assembly 602. The display sign 100 is useful to display and convey advertising, marketing, promotional, educational, or governmental information. The frame assembly 602 can include a rectangular front frame 604 which peripherally surrounds and is fixedly secured to the front, planar or flat, rectangular, rigid, stationary web 606 of the billboard 600. The frame assembly 602 can also include a rectangular rearward back frame 608 which periph-

erally surrounds and is fixedly secured to the rearward, planar or flat, rectangular, rigid, stationary underlying back web 610 of the billboard 600. Each frame can have a top elongated longitudinal horizontal beam 612, a bottom elongated longitudinal horizontal beam 614, a left upright side strut 616, and a right upright side strut 618. The upright struts 616 and 618 extend vertically between and connect the horizontal beams 612 and 614. One or more upright posts 620 and 622 or vertical columns are connected to the bottom beam 614 and provide a stand to elevate the billboard above the ground. Upright side walls 624 and 626 providing connecting members can extend between and connect the front and rear frames 604 and 608. In some circumstances, it may be desirable for the display sign to have a platform, scaffolding, braces, and/or back lit flood lights, as well as omit part or all of the back frame and side wall connecting members. If a single post is desired, it can be connected to the middle portion of the lower horizontal beam or cantilevered to a side section of the lower horizontal beam. Only one front web and one rear web is required, if the sign is mounted parallel to the traffic flow. If it is desired that the sign be positioned perpendicular or transverse to the traffic flow and that the sign display information in both opposing direction of traffic, then dual opposing front and rear webs can be used such as with a V-shaped frame assembly.

As shown in Figures 2 and 4, the front web 606 of the display sign 100 has a grid-like pattern providing a grid 160 with vertical bars 300 and slit-like spaces providing vertical transparent windows 320 between the bars. If solid rigid metal bars are preferred, the side struts of the front frame may be omitted, if desired. As best shown in Figure 3, the rearward web 604 of the display sign 100 has offset superimposed images 120 including a first image 121 with stripes 421 and spaces 460, between the stripes 421, and a second image 122 with stripes 422 with spaces 461, between the stripes 422. The illustrated images are

of a cowboy, a rope providing a lasso or lariat, and horses. A substantial portion of the stripes 422 of the first image are aligned in registration and positioned in spaces 461 of the second image 122, and a substantial portion of the stripes 422 of the second image 122 are aligned in registration and positioned in spaces 460 of the first image 121, in the superimposed image 120. The grid 160 and images 120-122 are preferably made in the manner previously described.

In use, when a pedestrian or other observer moves his head or changes locations, the images of the display sign 100 have the illusion of moving. For example, in Figure 5, the cowboy's upright arm and lasso is cocked or tilted towards his head. In Figure 6, the cowboy's upright arm and lasso have moved left and laterally outwardly away from the cowboy's head, the head of the horse the cowboy is riding is lower and the bigger horse's tail is higher than in Figure 5, and the feet of the smaller horses in the background have changed position, to give the illusion of galloping horses.

The educational display game and toy 116 of Figures 38 and 39 has a rectangular frame assembly 700 providing a housing 702 which peripherally surrounds and is fixedly secured to a stationary front rectangular web 704. The housing 702 has front wall portions 706 providing the front of the housing which comprises a generally rectangular, removable front frame 708. The front frame 708 has horizontal (longitudinal) and vertical (lateral) sections 710-713 as viewed from above the front of the educational display game. The housing 702 has a back 714 which provides the back of the housing. The housing 702 also has transverse rectangular walls including horizontal side walls 716 and 718 and vertical end walls 720 and 722, which extend between and connect and are perpendicular to the back wall 714 and front 706 of the housing 702. Sets of latches 724 and 726 are connected to the side walls 716 and 718 to latch and detachably secure the side walls to the

front 706 of the housing 702.

Manually grippable rotatable, control knobs 728 and 730 extend outwardly and downwardly from the lower bottom end wall 718 of the housing 702, as shown in Figures 38 and 39. Scrolls 732 and 734 comprising elongated parallel upright, tubular cylindrical rollers, cylindrical bars or cylinders 736 and 738 can be provided with slots or fasteners to securely grasp and hold a rearward rotatable, scrollable, flexible, moveable, back web 740. The scrolls 732 and 734 have slots or slotted teeth 742 and 744 which receive, are operatively connected to, and driven by drive teeth or lugs 746 and 748 of the control knobs 728 and 730, respectively. The scrolls (rollers) 732 and 734 and knobs 728 and 730 provide a scroll assembly, which operatively connected to the housing 702, to rotatively move the rearward web 726. The scrolls 732 and 734 are positioned within the interior of the housing 702.

In operation one of the scrolls, such 723, of the educational display game 116 (Figures 38 and 39) provides a lead roller or lead scroll and its associated knob, such as 728, provides a lead advance mechanism, while the other scroll, such as 734, provides a trailing roller or trailing scroll and its associated knob, such as 730, provides a trailing mechanism, or vice versa. When the lead mechanism (knob) 728 is rotated in one direction, such as counterclockwise, the lead roller 732 rotates in the same direction and rotatively moves, advances, and winds the rearward web 740. The trailing mechanism (knob) 730 and trailing roller 734 can move (follow) in the same direction as the lead mechanism (knob) 728 and lead roller 732. When the trailing roller (scroll) 734 rotates in the same direction as the trailing knob 728, to rotatively move, retract, and crank the rearward web 740 in the same clockwise direction. The other knob 728 and scroll 732 can follow (move) in the same clockwise direction. In some circumstances, it may be desirable to use cranks or other types of handles instead of knobs or it may be desirable to

position the game horizontally or at an angle of inclination instead of vertically.

As shown in Figures 38 and 39, the front web 704 of the educational display game 116 has a grid-like pattern providing a grid 76 with vertical bars 316, as viewed from above the top of the display game, and slit-like spaces providing vertical transparent windows 336 between the bars. The rearward (back) web 740 has offset superimposed images 152 including first images 153 with stripes 453 and spaces, between the stripes 453, and second images 154 with stripes 454 and spaces between the stripes 454. The illustrated images are of a banana, balloon, and butterfly. The stripes 453 of the first images 153 are aligned in registration and positioned in the spaces of the second images 154, and the stripes 454 of the second images 154 are aligned in registration and positioned in the spaces of the first images 153, in the superimposed images 152. The grid 176 and images 152-154 are preferably made in the manner previously described.

In use, when the knobs 728 and 730 are turned, pivoted, or rotated, either clockwise or counter-clockwise, the rear web 740 will move behind the stationary front web 704, and the images have the illusion of moving. For example, in Figure 38, the head (banana peel) of the banana is open, the left arm is stretched general horizontally, and the wings of the butterfly are fully open. In Figure 39, the head (banana peel) of the banana is closed, the left arm is raised, the wings of the butterfly are almost closed, and the balloon has moved higher and closer to the banana than in the other Figure 38.

The educational display game and toy 118 of Figure 40 is functionally and structurally similar to the educational game and toy 116 of Figures 38 and 39, except that the scrolls 732 and 734 and rearward web 74026 are housed, enclosed, and contained in a removable cassette or cartridge 750, the upper side 716 is open to define a rectangular slot 751 to slidably receive the cassette 750,

and the knobs 752 and 754 extend outwardly from the frame 708. The front 706 of the housing 702 has a rectangular opening 755 for viewing of the grid 176 of the front web 706 as well as the rearward back web 740. The inner
5 (inwardly facing) ends of the knobs 728 and 730 can have teeth 756 and 758 or comprise level gears to engage and drive corresponding teeth 760 and 762 or gears connected to the lower ends of the scrolls 722 and 724 when the cassette 750 is properly positioned in the slot 752. The cassette
10 (cartridge) can be replaced with other cassettes (cartridges) having different images or stories: thereon, so that many different images and stories can be displayed.

The display devices produced by the described process, provide an animation system in which animations appear as
15 a result of movement of the overlay grid (front web), patterns or images (rearward web), and/or the observer. The display system comprises one or more grid overlays positioned upon, against, over, or partially attached to the rearward web comprising the underlying artwork,
20 message, etc. Animation will occur, when the grid overlay is positioned against or very close to the rearward web comprising the underlying artwork (illustrations or other images) and the grid overlay or artwork is moved. Animation will also occur, when the overlay is placed
25 apart, or partially attached to underlying artwork, and the grid, underlying artwork, or eye position of the observer is moved. Animation is caused by the overlay hiding and obstructing all or part of the view of the underlying art work or message.

30 For repeated or stepped action, two or more artworks (images) can be sliced into pieces by means of hand work, conventional stripping, and/or preferably by the described computer technology. When one or more overlays are placed over the underlying combined images, the overlay(s) covers
35 at least part of the underlying images, allowing for the viewer to see only one of the two or more segments of the combined superimposed images. By moving the overlays or

underlying graphics (images), or combination of the two, the viewer can see the next segment (image), while the previous segment (image) is hidden by the overlay, thereby creating an illusion of repeated, stepped action and animation.

In order to attain the illusion of movement, such as horizontal, vertical, rotating, radial, or irregular movement, the patterns (images) comprising the underlying artwork or message is interfered by from different directions, thus creating optical illusions known as moire. When the overlay (front web) and underlying images (rearward web) are placed without any space or very little space therebetween, the spacing between the stripes and bars have to correspond to cause repeated or stepped animation. Patterns on both need not be identical to create optical illusion or moire. In such situations, movement(s) of overlay(s) or underlying element(s) or combination of both will cause animation, but movement of viewer's eye position alone can not create animation.

Grids can be vertical, horizontal, and/or at any angle. Lines can be straight, curved, and/or irregular. Preferably, the lines of the grids are evenly spaced in case the movement of any images is straight (linear). When the movement is not straight (linear), such as curved or rotating, the lines of the grid may not be parallel to each other and the spacing may be uneven. The grid can be of different sizes, spacing, or at different angles, and movements can be forward, backward, upward, downward, or in any direction, as desired by the designer. At any given pattern, the lines of the grid are substantially parallel to each other and at equal intervals and spacing when the movement is straight. Generally, the overlay grid precisely covers at least one combined pattern at a time.

When different formulations on either overlays or the underlying images are not identical to each other, many movements will be created, such as vertical, horizontal, angular, rotating, radial, curved, etc. Movement of the

images is controlled by the direction, speed, and angle of movement of the webs and by the thickness, spacing, shape, and angle of the bars on the grid.

Overlays and underlying back webs are preferably flat or planar, but they can be bent, curved, cylindrical or any combination of the above.

When the overlay (front web) and underlying element (rearward web) are spaced apart from each other, or partially attached to each other, the physical size of the overlay grid should be smaller than that of the underlying elements (superimposed images), since the overlay is closer to the viewer and overlaps and show one element (image) at a time to cause repeated and stepped animation. In this case, movement of the front web, rearward web, and/or viewer's position. The display sign of this invention can create the illusion of movement and animation without any moving parts, by varying the viewer's position.

For complex objects created which contain many colors, different drawing techniques such as masking, blending, patterning, can be used. The mask can have the appearance of a comb or a brush, and enables the designer or operator to mask out and eliminate parts of the objects (image) which are located in the void spaces of the masking pattern, thereby creating masked images which are spliced and spaced into pieces. Masking pattern can be in any shape, such as curved and/or, straight, as long as the lines conform and correspond to the the patterns on the overlay which will affect movement.

For a simple object with few colors, the designer can achieve the same results by first creating objects which conform the pattern on the overlay, then masking the object with the pattern which has an outline shape of the finished masked object. In this case, the splicing has already been done, so by masking with the pattern, any object outside of the pattern will be eliminated, thereby forming the masked objects.

Two masked objects can be overlapped, one right over

the other very precisely, in a position so that one masked object is located in the void areas of the other object. The combined objects comprise two or more images in which the image alternate by one unit of the grid pattern.

5 The grid pattern placed on the combined objects (superimposed images), hides one object while showing the other object. Moving the overlay grid and/or underlying web, will create illusion of repeated and/or directional animation.

10 It is possible to create images combining three or more objects to perform three or more stepped motions. For three step animation, three objects are combined in the same manner described above, except void parts of a masked objects (images) are twice as wide, so two other images
15 will be positioned into these void spaces. In such circumstances, the overlaying grid has lines (bars) twice as thick as the spaces between them, exposing one image at a time while hiding the other two images.

20 Four or more stepped movements are possible by increasing the numbers of objects (images) and thickness of the lines (bars) on the overlay grids.

25 When the grid is placed over the combined superimposed offset image, it hides all but one of the underlying images. By moving the grid, graphic or eye by one unit, the other unit of the graphic will appear while hiding the other images at the same time. The combined graphics can provide one or more repeated motions.

30 The overlay grid can be placed right on the graphic. In this case, the shape and spacing of the grid pattern on both the graphic and overlay exactly match. In such circumstances, animation is caused by either movement of the graphic, overlay, or combinations of the above, and movement of viewpoint alone typically will not cause animation.

35 When the overlay grid is placed away from the graphic, movement of either the graphic, overlay grid, location (viewpoint) of the observer, or any combination of the

above, will cause animation. Even when the graphic and overlay grid are placed against each other, movement of the viewpoint will cause animation. Such animation will also occur, when the display is placed on moving vehicles and objects, such as buses, trains, elevators, etc.

Spacing of the pattern lines on the overlay grid should be smaller than that of the graphic because the overlay grid is closer to the observer (viewpoint). The distance between the overlay grid and the graphic (rearward web) can be dependent upon the distance to the observer (viewpoint) or focal point.

If desired, the space between the graphic (rearward web) and the overlay grid (front web) can be filled with transparent materials, such as transparent acrylic or other plastic, glass, etc.

By increasing the number of units of the grid line width compared to the space (3, 4, 5, etc.), animation steps can be increased (3, 4, 5, etc.). The more animation steps desired, however, the more portions of the graphic will be obstructed during viewing of other portions of the graphic.

A plate lens or cluster of anamorphic lenses 800 (Figure 41) or elongated transparent rods or bars 900 (Figure 42) can comprise or be used in lieu of the described grids for the previously described displays, in order to provide a lens display system or a transparent rod display system. Each lens or rod can be made of glass or impact-resistant plastic and is placed (spaced) in front of the superimposed images 802 or 902 on the underlying or rearward web 804 or 904. The space between the lens or rods and the rearward web can be void or fully or partially filled with transparent spacer material. One or both sides or surfaces of each lens or transparent rod can be convex, concave, curved, conical, rectangular, cylindrical, planar or flat. The lens(es) or transparent rods advantageously magnify and enlarge the superimposed images 802 or 902 on the underlying or rearward web 804 or 904 and cooperate

with the web 804 or 904 of superimposed images to provide the appearance of movement and animation of the images as the angle of observation changes, e.g. the observer moves his head or changes his location.

5 The lens(es) 800 (figure 41) or transparent rods 900 (Fig. 42) can also have a grid-like pattern (grid) of lines or bars thereon, similar to the grids previously shown and described. These lines or bars can be horizontal, vertical, diagonal, angular, curved, parallel, skewed, radiant or
10 radial from points within or outside the lens or rod.

 Animation systems utilizing opaque bars display only one image through its windows at any given time, while one or more images are hidden (blocked) by the opaque bars. One of two or more images are viewed progressively to
15 create an optical illusion of animation.

 An animation system or display with a plate lens or cluster of anamorphic lenses, which when placed vertically, can enlarge images horizontally while retaining the vertical scale. Each lens enlarges at least part of one
20 image to fill up one grid's width, so that the other images are hidden from view. The viewing angle from the observer to the lens determines which image is seen. Different images appear as the angle of sight changes.

 A vertical series, set, array, and matrix of
25 transparent rods can function and be used in lieu of anamorphic lenses to enlarge the images, such as more the 600% in a perpendicular or horizontal direction, while retaining the height (vertical scale). By lining the transparent rods in side-by-side relationship to form a
30 planar set of rods, the rods function similar to a sheet lens and can display as many as six images progressively. Transparent rods are particularly useful for large posters and billboards since manufacturing, constructing, installing, and assembling a large sheet lens or cluster of
35 lenses for a large poster or billboard may be cumbersome, difficult, and/or expensive. The transparent rods can be spaced in front of the rearward web or can be placed in

contact against the rearward web.

Preferably, the number of images should not exceed more than the rate of magnification of the lens(es). Six different images can be used with a plate lens or series
5 (cluster) of lenses to magnify the images, such as more than 600%. Preferably, the width of the set of combined images should be about equal or less than one lens unit. For such use, the set of images should be aligned in registration to a corresponding lens unit. Two to six step
10 motions can be used with the same graphic material. In such cases, the width of a set of any number of combined images should be equal or less than a lens unit. Because of its nature, opaque bars system may make some images appear darker, especially when two or more images
15 are combined. The lens and rods display system solves this problem since opaque bars or a grid are not required to hide parts of the images. Because less spacing is required between rearward web and the lens(es) or transparent rods than a grid, a lens or rod display system can be more
20 compact than a grid display system. Manufacturing and cleaning and other maintenance expenses are generally similar for the lens, rod, and grid display systems.

The information displaying container assembly 1000 of Figures 43a-43d is generally functional similar to the
25 package assembly shown in Figures 25-28, except as described below. The container assembly 1000 has a beverage container 1010, such as a cup, glass, or mug. The container 1010 provides a display container with a front surface 1012 comprising a stationary arcuate rearward web
30 1014 with superimposed (combined) first and second striped images 1016-1018 thereon as described above. The images 1016-1018 on the rearward web 1014 of the container 1010 are formed in a manner similar to the images described above. The container 1010 can have tapered, slanted or
35 upright walls 1020.

The container assembly 1000 has a tubular annular sleeve 1022 with a circular cross section. The sleeve

1022 complements the shape of the container 1010 and slides upon and rotates about the container walls 1020. The sleeve 1022 comprises a front web spaced in front of and substantially parallel to the rearward web 1014 on the container 1010. Rotation, sliding or other movement of the sleeve 1022 will vary the image being viewed to give an animation effect. The front web (sleeve) comprises a substantially transparent viewable portion with a set of aliquot slit-like spaces 1024 providing a series of substantially rectangular transparent windows for viewing only the first superimposed images from first angular position and for viewing only the second superimposed images from a second angular position.

As shown in Figure 43b, the sleeve has a grid-like pattern with a set of aliquot spaced opaque bars 1030 with substantially rectangular portions positioned between the rectangular windows for blocking the view of the second superimposed image from the first angular position and for blocking the view of the first superimposed image from the second angular position. The first spacer portions span a width less than said bars and are obstructed and blocked from view by the bars in the first angular position. The second spacer portions span a width less than the bars and are obstructed and blocked from view by the bars in the second angular position.

The beverage and display container assembly 1050 of Figure 44 is similar to the beverage and container assembly 1000 of Figures 43a-43d, except the container comprises a thermal mug 1060 with a transparent outer shell and cup 1062 having a grid thereon.

The beverage and display container assembly 1070 of Figure 45 is similar to the beverage and container assembly 1000 of Figures 43a-43d, except the container comprises a thermal mug 1080 and the tubular transparent sleeve 1090 comprises a magnifying web 1092 for enlarging the appearance of the images and for facilitating viewing of the images on the back web of the container as the angle of

view changes. The magnifying web can comprise an array of substantially transparent rods, plate lens, a cluster of anamorphic lenses, which function similar to those described in Figures 41 and 42.

5 The information displaying lampshade assembly 1100 of Figures 46 is generally structurally and functionally similar to the container assembly shown in Figures 43a-43d, except as described below. The lampshade assembly 1100 has a lampshade 1110 made of light transmissive material for
10 permitting passage of light while minimizing glare. The lampshade can be a truncated lampshade, a frustroconical lampshade, or cylindrically shaped lampshade. Other shaped lampshades can also be used.

 The lampshade 1110 comprises stationary arcuate
15 rearward web 1114 with superimposed (combined) first and second striped images 1116-1118 thereon as described above. The images 1116-1118 on the rearward web 1014 of the lampshade 1110 are formed in a manner similar to the images described above. The lampshade 1110 can have tapered,
20 slanted or upright walls 1120.

 The lampshade assembly 1100 has a tubular annular sleeve 1122 with a circular cross section. The sleeve 1122 complements the shape of the lampshade 1110 and slides upon and rotates about the lampshade walls 1120. Rotation,
25 sliding or other movement of the sleeve 1122 will vary the image being viewed to give an animation effect. The sleeve 1122 comprises a front web spaced in front of and substantially parallel to the rearward web 1114 on the container 1110. The front web (sleeve) comprises a
30 substantially transparent viewable portion with a set of aliquot slit-like spaces 1124 providing a series of substantially rectangular transparent windows for viewing only said first superimposed images from first angular position and for viewing only said second superimposed
35 images from a second angular position. The sleeve 1122 has a grid-like pattern with a set of aliquot spaced opaque bars 1130 with substantially rectangular portions

positioned between the rectangular windows for blocking the view of the second superimposed image from the first angular position and for blocking the view of the first superimposed image from the second angular position. The first spacer portions span a width less than said bars and are obstructed and blocked from view by the bars in the first angular position. The second spacer portions span a width less than the bars and are obstructed and blocked from view by the bars in the second angular position.

10 The lampshade assembly can have a tubular transparent sleeve comprising a magnifying web for enlarging the appearance of the images and for facilitating viewing of the images on the back web of the container as the angle of view changes. The magnifying web can comprise an array of
15 substantially transparent rods, plate lens, a cluster of anamorphic lenses, which function similar to those described in Figures 41 and 42.

The container display assembly 1150 of Figures 47 and 48 comprises a bottle 1160 with a rearward arcuate backwall or web 1162 having superimposed (combined) images 1164 and
20 1166 thereon. The front arcuate wall or web 1170 of the bottle 1160 has a grid 1180 thereon aligned diametrically opposite the images 1164 and 1166. When water or other transparent liquid is placed in the bottle above the height
25 of the images as shown in Figure 48, the water or liquid serves to magnify the images 1164 and 1166. The grid functions as described above with respect to Figure 4. The images change as the angle of view of the viewer changes,

The information display assembly 1200 of Figures 49-52
30 is generally functional similar to the package assembly of Figures 25-28 and to the displays of Figures 20-37, except as described below. The display assembly has an envelope 1202 (Figures 49-50) or other information viewing display 1210 (Figures 51-52), such as a magazine, comic book, paper
35 back book, hard back book, book cover, page, brochure, or pamphlet. The information display has a pocket 1212 with a substantially flat or planar rearward web 1214 and a

substantially planar flat or planar front web 1216 spaced in front of and substantially parallel to the rearward web 1214. At least one of the webs, e.g. the rearward web 1214, is moveable relative to the other web, e.g. stationary front web 1216. Pulling, pushing, sliding or other movement of the rearward (back) web 1214 will vary the image being viewed through the front web 1216 to give an animation effect. While the described arrangement is preferred, in some circumstances, it may be desirable to have a moveable front web and a stationary rearward web to produce an animation effect.

The rearward web 1214 has superimposed (combined) striped images 1218-1220 thereon which are formed in a manner similar to the images described above.

The front web 1216 comprises a sleeve with a transparent viewable portion. The front web has a set of aliquot slit-like spaces 1222 which provide a series of substantially rectangular transparent windows for viewing only the first superimposed images from a first angular position and for viewing only the second superimposed images from a second angular position. The front web 1216 has a grid-like pattern 1224, similar to that previously described, comprising a set of aliquot spaced opaque bars with substantially rectangular portions positioned between the rectangular windows for substantially blocking the view of the second superimposed image from the first angular position and for substantially blocking the view of the first superimposed image from the second angular position.

As described previously, the relationship of the width of the bars of the grid, the width of the stripes of the superimposed images, and the spacing between the front web and the rearward web, to a focal point of an observer, are in accordance with the following formulas:

$$S = B - D \quad \text{and}$$

$$A/B = C/D$$

wherein S = the spacing between the front web

and the rearward web

B = the distance between the rearward
and a focal point of the observer

D = the distance between the front web
and focal point of the observer

A = maximum width of any stripe of
the images

C = maximum width of any bar of the
grid.

5
10 The information display assembly 1250 of Figures 53-54
is generally functional similar to the information display
assembly of Figures 51-52 except that the rearward web 1252
with the superimposed images 1254 and 1256 is stationary
and the sleeve (grid) comprises a magnifying web 1260 for
15 enlarging the appearance of the images and for facilitating
viewing of the images on the back web as the angle of view
changes. The magnifying web can comprise an array of
substantially transparent rods, plate lens, a cluster of
anamorphic lenses, which function similar to those
20 described in Figures 41 and 42.

The information display assembly 1300 of Figures 55-56
is generally functional similar to the sign of Figures 3-6,
except as described below. The display assembly 1300
comprises a greeting card 1302 with a back web 1304 having
25 superimposed (combined) images 1306 and 1308 thereon. A
pop up rectangular frame 1310, made of paperboard or
plastic, secures holds a rectangular front web 1312
comprising a grid 1314. When the folded cover 1316 of the
greeting card 1302 is opened, the pop up frame 1310 expands
30 towards the viewer. Viewing of the images changes as the
angle of view of the viewer changes. When the greeting
card 1302 is closed, the frame 1310 is in a compressed
contracted closed position.

The information display assembly 1350 of Figures 57-58
35 is generally functional similar to the information display
assembly of Figures 51-52, except as described below. The
display assembly 1350 comprises a greeting card 1352 with

a back web 1354 having superimposed (combined) images 1356 and 1358 thereon. The front web 1360 comprises a moveable grid 1362. The left edge 1364 of the front web 1360 is glued, bonded or otherwise secured to the inside page 1366
5 of the cover 1368 of the greeting card 1352. When the cover 1368 of the greeting card 1352 is opened, the grid is pulled to the left so that the images change.

The information display assembly 1400 of Figures 59-60 is generally functional similar to the information display
10 assembly 1300 of Figures 55-56, except as described below. The display assembly 1400 comprises a compact disc (CD) case and package assembly 1402. An insert 1404 comprises a back web 1406 having superimposed (combined) images 1408 and 1410 thereon. A transparent plastic compact disc cover
15 1412 has a grid 1414 thereon. Viewing of the images changes as the angle of view of the viewer changes. The cover 1412 can be etched or scratched to provide a magnifying web for enlarging the appearance of the images and for facilitating viewing of the images on the back web
20 of the container as the angle of view changes. The magnifying web can also comprise an array of substantially transparent rods, plate lens, a cluster of anamorphic lenses, which function similar to those described in Figures 41 and 42.

25 The information display assembly 1500 of Figures 61-62 is generally functional similar to the display assembly of Figures 19-24, except as described below. The display assembly 1500 comprises a laser disc case and package assembly 1502 with a pocket 1504. A rotatable wheel or
30 disc 1506 is positioned in the pocket 1504. The wheel 1506 comprises a back web 1508 having superimposed (combined) images 1510 and 1512 thereon. The stationary front cover 1514 of the laser disc case 1502 has a window 1516 with an arcuate radial grid 1518 therein. Viewing of the images
35 changes as the wheel 1506 is rotated.

The information display assembly 1550 of Figures 63-64 is generally functional similar to the display assembly of

Figures 61-62, except as described below. The display assembly 1550 comprises a book 1552 with a rotatable cover 1554 and pages 1556. The cover 1554 and pages 1556 comprises rearward webs with superimposed (combined) images 1560 and 1562 thereon. A rotatable arcuate front web 1570 comprises a radial grid 1572. The front web 1570, cover 1554, and pages 1556 can be held by a screw-type fastener 1580. Viewing of the images changes as the grid is rotated or when the cover or pages are turned (rotated).

The display can be used in display signs, paintings, sculptures, back lit transparencies, advertisements, countertop displays, beverage containers, lampshades, packaging, billboards, posters, toys, educational games, books, magazines, book covers, envelopes, stationery, brochures, pamphlets, promotional publications, compact disc covers, laser covers, murals, stores, and other applications where animations are effective or desirable.

It is to be understood, that images comprising other letters, words, symbols, pictures, designs, logos, and illustrations, can be used in lieu of the images illustrated in the Figures.

Among the many advantages of the novel display and process are: (1) Outstanding marketing, advertising, and promotional appeals; (2) Excellent ability to interestingly disseminate educational, safety, medical, and government information; (3) Superior product; (4) Superb quality; (5) Impressive; (6) Cost effective; (7) Simple to install; (8) Easy to use; (9) Economical; (10) Attractive; (11) Efficient; and (12) Effective.

Although embodiments of the invention have been shown and described, it is to be understood that various modifications and substitutions, as well as rearrangements of parts, components, and process steps, can be made by those skilled in the art without departing from the novel spirit and scope of this invention.

What is claimed is:

1. A display, comprising:

a rearward web having at least two superimposed images thereon, said rearward web comprising at least a portion of a member selected from the group consisting of a container, cup, glass, mug, bottle, package, box, carton, wrapper, lampshade, magazine, comic book, paper back book, hard back book, cover, page, envelope, greeting card, compact disc cover, laser disc cover, brochure, and pamphlet,;

a front second web positioned in front of said rearward web, said front web defining transparent window portions for viewing said images;

each of said images comprising a viewable opaque portions and non-viewable spacer portions, said viewable opaque portions comprising an array of spaced opaque stripes; and

at least a portion of said opaque stripes of said first image being positioned in at least a portion of said spacer portions of said second image, and at least a portion of said opaque stripes of said second image being positioned in at least a portion of said spacer portions of said first image.

2. A display in accordance with Claim 1 said transparent window portions permit viewing of said images as the angle of view changes, said stripes having a width not greater than the width of one the window portions for alignment and viewing through said window portions, said viewable opaque portions comprising an array of spaced opaque stripes, said front web comprises magnifying means for enlarging the appearance of said images, said magnifying means selected from the group consisting of an array of substantially transparent rods, plate lens, a cluster of anamorphic lenses, and a grid-like pattern.

3. A display in accordance with Claim 1 wherein said front web comprises a sleeve having a grid-like pattern defining transparent spaces providing a series of windows

for viewing one of said images and having opaque bars between said windows for blocking the view of the other images, and one of said webs being moveable relative to the other web to facilitate viewing of the images.

5 4. A display, comprising:

 a container assembly for displaying information;
 said container assembly comprising a display
 container and a sleeve;

 said display container selected from the group
10 consisting of a container, cup, glass, mug, bottle, box,
 carton, wrapper, and package, said container comprising a
 stationary rearward web, said rearward web having first and
 second superimposed striped images thereon;

 said sleeve comprising a front web spaced in
15 front of said rearward web, said front web comprising a
 substantially transparent viewable portion with a set of
 aliquot slit-like spaces providing a series of
 substantially rectangular transparent windows for viewing
 only said first superimposed images from first angular
20 position and for viewing only said second superimposed
 images from a second angular position;

 said first superimposed image on said rearward
 web having viewable first opaque portions and substantially
 rectangular obstructed invisible first spacer portions,
25 said viewable first opaque portions comprising an array of
 aliquot spaced substantially rectangular first strips with
 first indicia thereon comprising some of said information,
 said first strips having a width less than said windows and
 being aligned in registration with said windows for viewing
30 in said first angular position;

 said second superimposed image on said rearward
 web having viewable second opaque portions and
 substantially rectangular obstructed second spacer
 portions, said viewable second opaque portions comprising
35 an array of aliquot spaced substantially rectangular second
 strips with second indicia thereon comprising some of said
 information, said second strips having a width less than

said windows and being aligned in registration with said windows for viewing in said second angular position; and

at least a portion said first opaque strips of said first superimposed image being positioned in at least a part of said second spacer portions of said second superimposed image on said rearward web, and at least a part of said second opaque strips of said second superimposed image being positioned in said at least a part of said first spacer portions of said first superimposed image or said rearward web.

5. A display in accordance with Claim 4 wherein:

said sleeve comprises a tubular sleeve having a grid-like pattern with a set of aliquot spaced opaque bars with substantially rectangular portions positioned between said rectangular windows for substantially blocking the view of said second superimposed image from said first angular position and for substantially blocking the view of said first superimposed image from said second angular position;

said first spacer portions spanning a width less than said bars and being substantially obstructed and blocked from view by said bars in said first angular position; and

said second spacer portions spanning a width less than said bars and being substantially obstructed and blocked from view by said bars in said second angular position.

6. A display in accordance with Claim 4 wherein said front web comprises magnifying means for enlarging the appearance of said images and for facilitating viewing of said images as the angle of view changes, said magnifying means selected from the group consisting of an array of substantially transparent rods, plate lens, a cluster of anamorphic lenses.

7. A display in accordance with Claim 4 wherein said web comprises an arcuate web, said sleeve has a substantially circular cross section, and said display

container is selected from the group consisting of a cup, glass, mug, and bottle.

8. A display, comprising:

a lampshade assembly for displaying information;

5 said container assembly comprising a lampshade container and a sleeve;

said lampshade being selected from the group consisting of a truncated lampshade, a frustroconical lampshade, and cylindrically shaped lampshade, said
10 lampshade comprising a stationary rearward web, said rearward web having first and second superimposed striped images thereon;

said sleeve comprising a front web spaced in front of and substantially parallel to said rearward web,
15 said front web comprising a substantially transparent viewable portion with a set of aliquot slit-like spaces providing a series of substantially rectangular transparent windows for viewing only said first superimposed images from first angular position and for viewing only said
20 second superimposed images from a second angular position;

said first superimposed image on said rearward web having viewable first opaque portions and substantially rectangular obstructed invisible first spacer portions,
25 said viewable first opaque portions comprising an array of aliquot spaced substantially rectangular first strips with first indicia thereon comprising some of said information, said first strips having a width less than said windows and being aligned in registration with said windows for viewing in said first angular position;

30 said second superimposed image on said rearward web having viewable second opaque portions and substantially rectangular obstructed second spacer portions, said viewable second opaque portions comprising an array of aliquot spaced substantially rectangular second
35 strips with second indicia thereon comprising some of said information, said second strips having a width less than said windows and being aligned in registration with said

windows for viewing in said second angular position; and
at least a portion said first opaque strips of
said first superimposed image being positioned in at least
a part of said second spacer portions of said second
superimposed image on said rearward web, and at least a
part of said second opaque strips of said second
superimposed image being positioned in said at least a part
of said first spacer portions of said first superimposed
image or said rearward web.

9. A display in accordance with Claim 10 wherein:
said sleeve comprises a tubular sleeve having a
grid-like pattern with a set of aliquot spaced opaque bars
with substantially rectangular portions positioned between
said rectangular windows for substantially blocking the
view of said second superimposed image from said first
angular position and for substantially blocking the view of
said first superimposed image from said second angular
position;

said first spacer portions spanning a width less
than said bars and being substantially obstructed and
blocked from view by said bars in said first angular
position; and

said second spacer portions spanning a width less
than said bars and being substantially obstructed and
blocked from view by said bars in said second angular
position.

10. A display in accordance with Claim 8 wherein said
front web comprises magnifying means for enlarging the
appearance of said images and for facilitating viewing of
said images as the angle of view changes, said magnifying
means selected from the group consisting of an array of
substantially transparent rods, plate lens, a cluster of
anamorphic lenses.

11. A display, comprising:
an information display assembly for displaying
information;

said information display assembly having an

information display selected from the group consisting of a magazine, comic book, paper back book, hard back book, book cover, page, envelope, greeting card, compact disc case, laser disc case, brochure, and pamphlet, said
5 information display having a pocket with a substantially planar rearward web and a substantially planar front web spaced in front of and substantially parallel to said rearward web, at least one of said webs being moveable relative to the other of said webs;

10 said rearward web having first and second superimposed striped images thereon;

 said front web comprising a substantially transparent viewable portion with a set of aliquot slit-like spaces providing a series of substantially rectangular
15 transparent windows for viewing only said first superimposed images from first angular position and for viewing only said second superimposed images from a second angular position, and said grid-like pattern comprising a set of aliquot spaced opaque bars with substantially
20 rectangular portions positioned between said rectangular windows for substantially blocking the view of said second superimposed image from said first angular position and for substantially blocking the view of said first superimposed image from said second angular position;

25 said first superimposed image on said rearward web having viewable first opaque portions and substantially rectangular obstructed invisible first spacer portions, said viewable first opaque portions comprising an array of aliquot spaced substantially rectangular first strips with
30 first indicia thereon comprising some of said information, said first strips having a width less than said windows and being aligned in registration with said windows for viewing in said first angular position, and said first spacer portions spanning a width less than said bars and being
35 substantially obstructed and blocked from view by said bars in said first angular position;

 said second superimposed image on said rearward

web having viewable second opaque portions and substantially rectangular obstructed second spacer portions, said viewable second opaque portions comprising an array of aliquot spaced substantially rectangular second strips with second indicia thereon comprising some of said information, said second strips having a width less than said windows and being aligned in registration with said windows for viewing in said second angular position, and said second spacer portions spanning a width less than said bars and being substantially obstructed and blocked from view by said bars in said second angular position; and

at least a portion said first opaque strips of said first superimposed image being positioned in at least a part of said second spacer portions of said second superimposed image on said rearward web, and at least a part of said second opaque strips of said second superimposed image being positioned in said at least a part of said first spacer portions of said first superimposed image or said rearward web.

12. A display in accordance with Claim 11 wherein said rearward web comprises a moveable web, and the relationship of the width of the bars of the grid, the width of the stripes of the superimposed images, and the spacing between the front web and the rearward web, to a focal point of an observer, are in accordance with the following formulas:

$$S = B - D \quad \text{and}$$

$$A/B = C/D$$

wherein

S = the spacing between the front web and the rearward web

B = the distance between the rearward and a focal point of the observer

D = the distance between the front web and focal point of the observer

A = maximum width of any stripe of the images

C = maximum width of any bar of the

grid.

13. A process for producing a display, comprising the steps of:

5 generating a first intermediate image with a central processing unit;

displaying said first intermediate image on a display screen of said central processing unit;

10 generating a second intermediate image on said central processing unit by electronically copying said first intermediate image, moving said copied image to a different location on said screen than said first intermediate image, and electronically altering and modifying at least part of the overall appearance and shape of said copied second intermediate image so that a
15 substantial portion of said second intermediate image is substantially different than said first intermediate image;

masking and striping said first intermediate image by substantially removing and deleting portions of said first intermediate image to form a striped first image
20 having an array of aliquot spaced obstructed first spacer portions defining a first set of spaces and an array of aliquot spaced first stripes comprising first opaque portions;

masking and striping said second intermediate
25 image by substantially removing and deleting portions of said second intermediate image to form a striped second image having an array of aliquot spaced obstructed second spacer portions defining a second set of spaces and an array of aliquot spaced second stripes comprising second
30 opaque portions;

superimposing, aligning, and moving said second striped image in offset relationship upon said first striped image so that at least part of said first opaque portions of said first striped image are aligned in
35 registration with and superimposed upon part of said spacer portions of said second striped image and at least part of said first spacer portions of said first striped image are

aligned in registration with and superimposed upon part of said second opaque portions of said second striped image;

printing said superimposed images on a rearward web comprising a member selected from the group consisting of a container, cup, glass, mug, bottle, box, package, wrapper, carton, greeting card, compact disc case, laser disc case, and lampshade; and

placing an array of substantially transparent rods in front of said superimposed images on said rearward web so that only one of said images can be viewed from a first angle of observation and a different one of said images can be viewed from another angle of observation.

14. A process in accordance with Claim 13 wherein said generating said first image includes optically scanning said first image with an optical reader and transmitting said scanned image to said screen.

15. A process in accordance with Claim 13 including generating from one to four additional intermediate images on said central processing unit by electronically copying one of said intermediate images, moving said copied additional images to a different location on said screen than the other image, and electronically altering and modifying at least part of the overall appearance and shape of said copied additional intermediate images so that said additional intermediate images are substantially different than said other images; masking and striping said additional intermediate images by screening, substantially removing, and deleting portions of said additional intermediate images to form striped additional images having an array of aliquot spaced obstructed spacer portions defining a set of spaces and an array of aliquot spaced stripes comprising opaque portions; and

superimposing, aligning, and moving said additional striped images in offset relationship upon said other striped images so that at least part of said opaque portions of said striped additional images are aligned in

registration with and superimposed upon part of said spacer portions of said other striped images and at least part of said spacer portions of said striped additional images are aligned in registration with and superimposed upon part of
5 said opaque portions of said other striped images.

16. A process for producing a display, comprising the steps of:

generating an overlying grid-like pattern with a central processing unit, said grid-like pattern having a
10 set of aliquot spaced substantially uniform opaque bars and a set of aliquot substantially uniform slit-like spaces providing windows between said bars;

displaying said grid-like pattern on a monitor comprising a display screen of said central processing
15 unit;

generating a first intermediate image said central processing unit, said first intermediate image being smaller than said grid-like pattern;

displaying said first intermediate image on said
20 screen at a different location than said pattern;

generating a second intermediate image on said central processing unit by electronically copying said first intermediate image, moving said copied image to a different location on said screen than said first
25 intermediate image and said pattern, and electronically altering and modifying at least part of the overall appearance and shape of said copied second intermediate image so that a substantial portion of said second intermediate image is substantially different than said
30 first intermediate image;

masking and striping said first intermediate image by moving and overlaying said grid-like pattern on said first image and screening, substantially removing, and deleting portions of said first intermediate image behind
35 said bars to form a striped first image having an array of aliquot spaced obstructed first spacer portions defining a first set of spaces behind said bars and an array of

aliquot spaced first stripes comprising first opaque portions behind and substantially corresponding to the width of said windows;

masking and striping said second intermediate image by moving and overlaying said grid-like pattern on said second intermediate image and screening, substantially removing, and deleting portions of said second intermediate image behind said bars to form a striped second image having an array of aliquot spaced obstructed second spacer portions defining a second set of spaces behind said bars and an array of aliquot spaced second stripes comprising second opaque portions behind and substantially corresponding to the width of said windows;

said images being formed substantially in accordance with the following formula

$$B_w = O_w - I_1$$

wherein

B_w = width of the opaque bars of the grid or grid-like pattern;

O_w = overall combined width of the stripes of all the images;

I_1 = combined width of the stripes of the first image

superimposing, aligning, and moving said second striped image in offset relationship upon said first striped image so that at least part of said first opaque portions of said first striped image are aligned in registration with and superimposed upon part of said spacer portions of said second striped image and at least part of said first spacer portions of said first striped image are aligned in registration with and superimposed upon part of said second opaque portions of said second striped image;

printing said grid-like pattern on a first web comprising a substantially transparent semi-rigid sleeve; and

printing said superimposed images on a rearward web comprising at least part of a member selected from the group consisting of a container, cup, glass, mug, bottle,

package, wrapper, carton, box, lampshade, magazine, comic book, page, envelope, greeting card, game, compact disc case, laser disc case, brochure, and pamphlet.

17. A process in accordance with Claim 16 wherein
5 said generating said first image includes optically scanning said first image with an optical reader and transmitting said scanned image to said screen.

18. A process in accordance with Claim 16 including
generating a third intermediate image on said
10 central processing unit by electronically copying said first intermediate image, moving said copied third intermediate image to a different location on said screen than said first image and said pattern, and electronically altering and modifying at least part of the overall
15 appearance and shape of said copied third intermediate image so that said third intermediate image is substantially different than said first and second intermediate images;

masking and striping said third intermediate
20 image by moving and overlaying said grid-like pattern on said third intermediate image and screening, substantially removing, and deleting portions of said third intermediate image behind said bars to form a striped third image having an array of aliquot spaced obstructed third spacer portions
25 defining a third set of spaces behind said bars and an array of aliquot spaced third stripes comprising third opaque portions behind and substantially corresponding to the width of said windows, and moving said grid-like pattern away from said third striped image to another
30 position on said screen; and

superimposing, aligning, and moving said third striped image in offset relationship upon said second striped image so that at least part of said second opaque portions of said second striped image are aligned in
35 registration with and superimposed upon part of said spacer portions of said third striped image and at least part of said second spacer portions of said second striped image

are aligned in registration with and superimposed upon part of said second opaque portions of said third striped image.

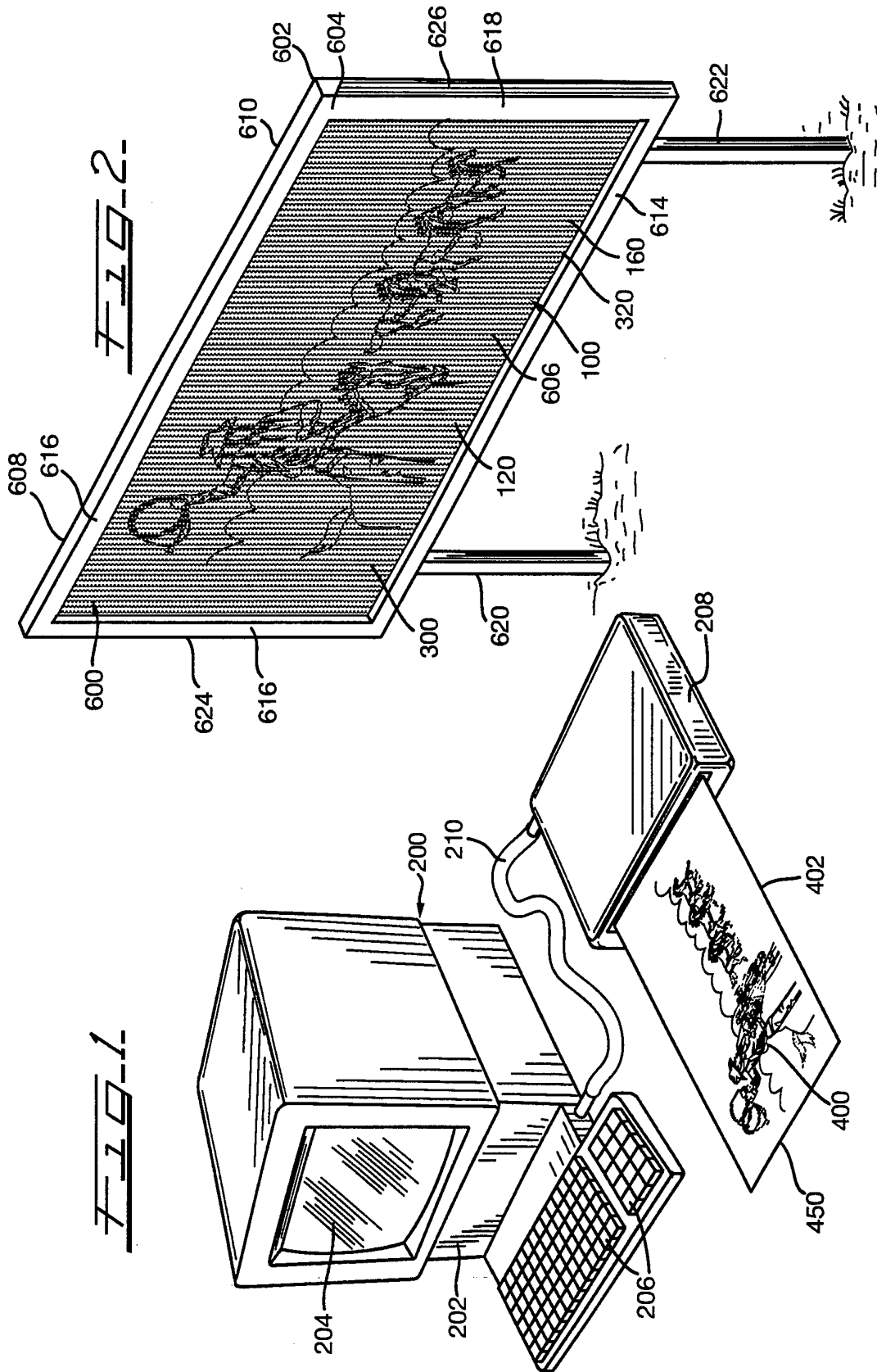

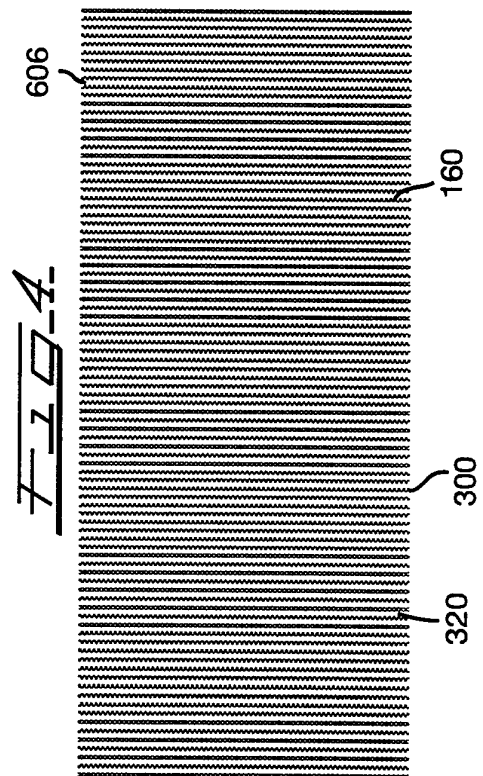
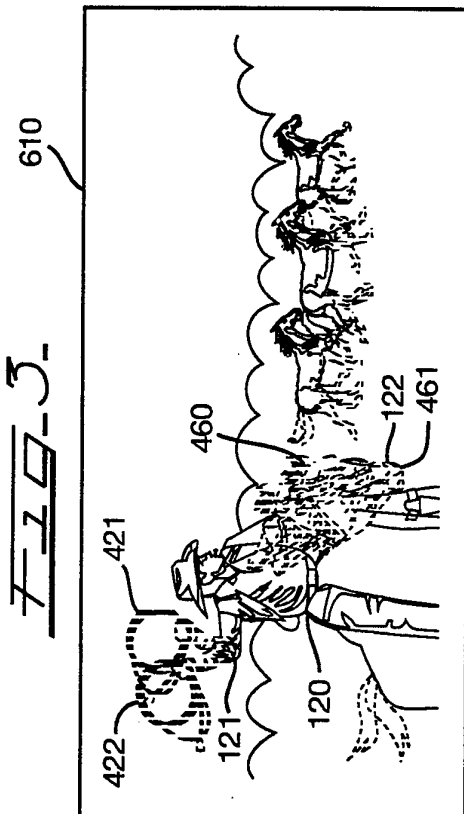
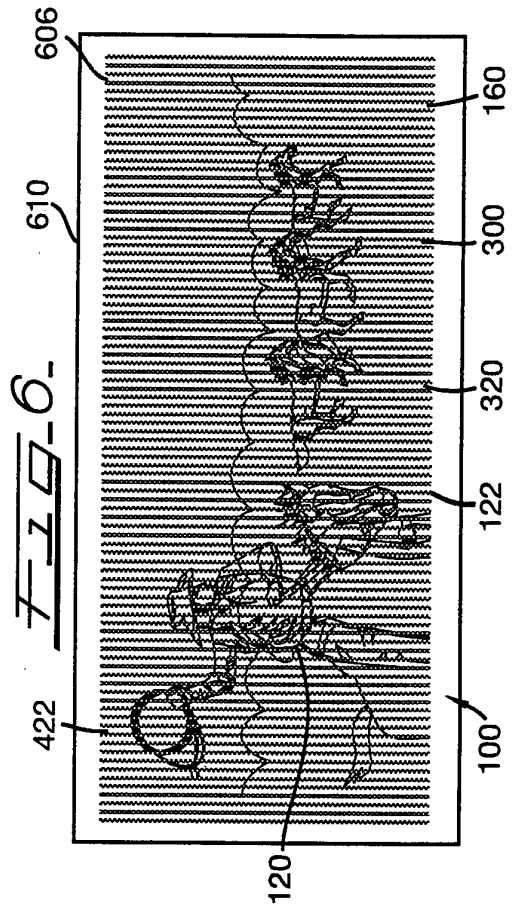
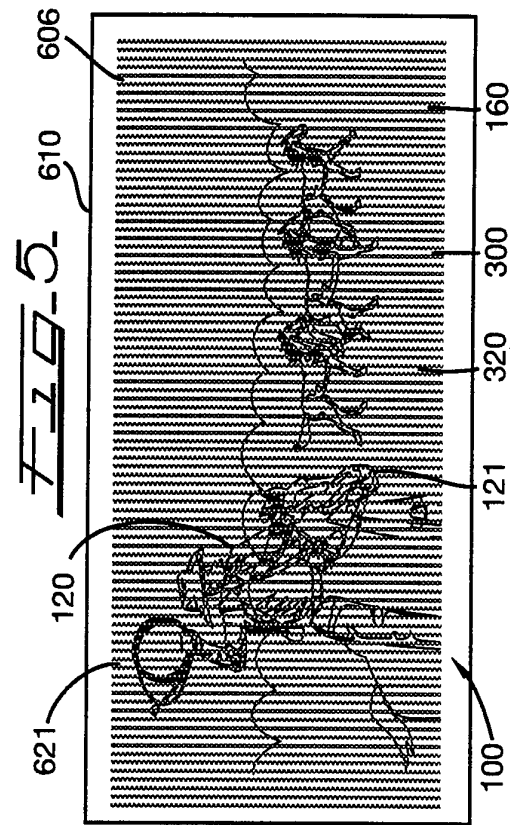

FIG-7

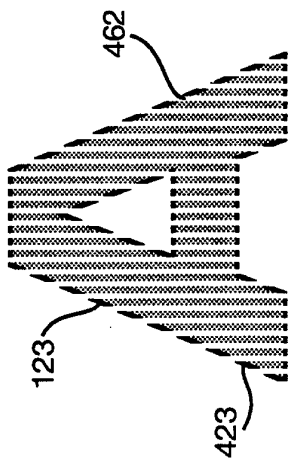

FIG-8

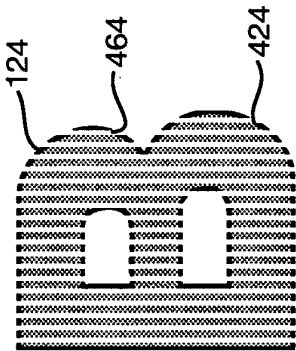

FIG-9

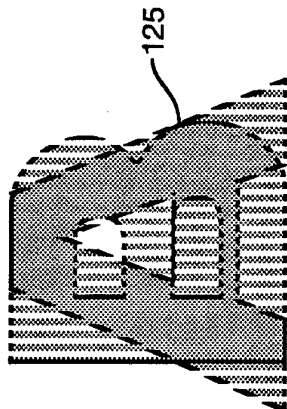

FIG-10

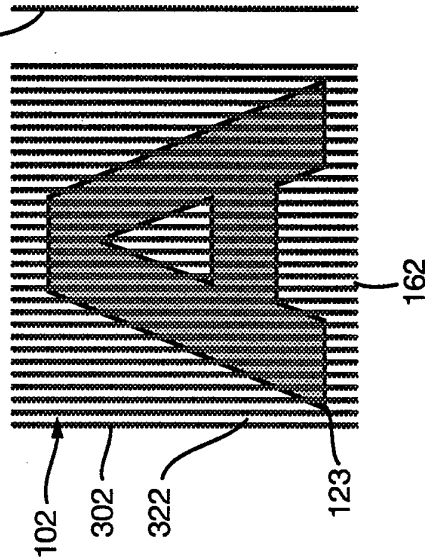

FIG-11

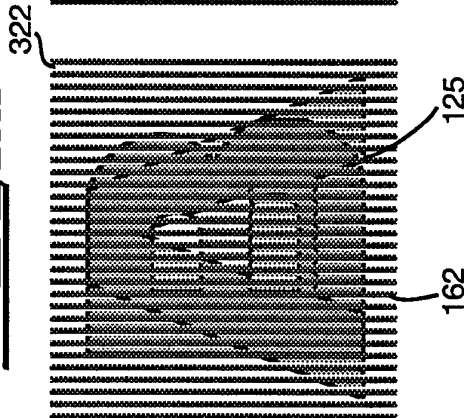

FIG-12

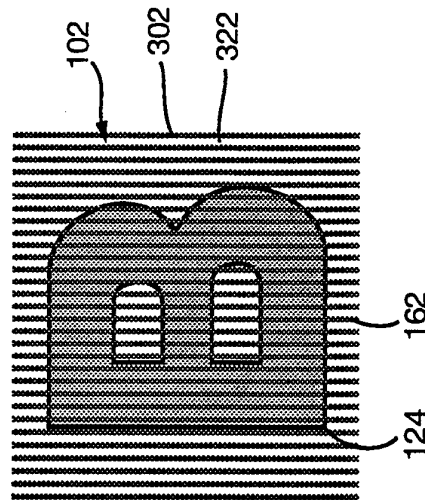

FIG-13

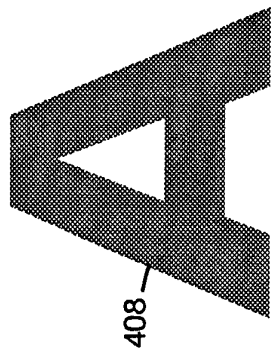

FIG-14

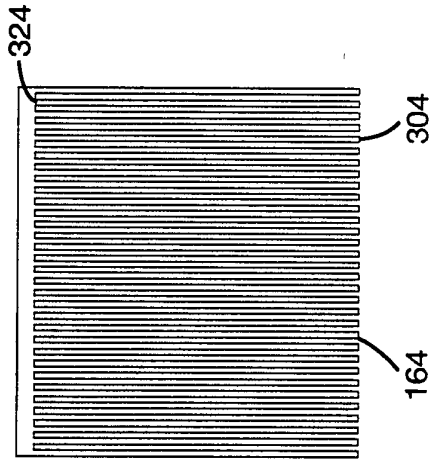

FIG-15

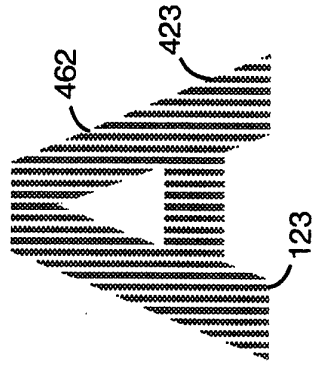

FIG-16

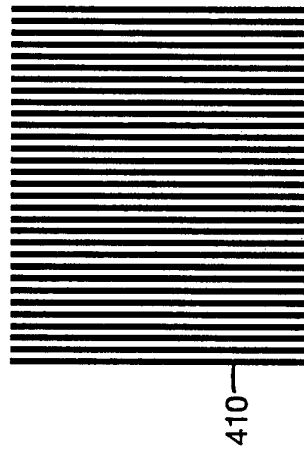

FIG-17

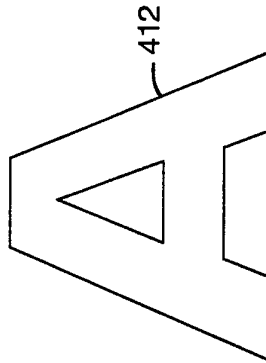

FIG-18

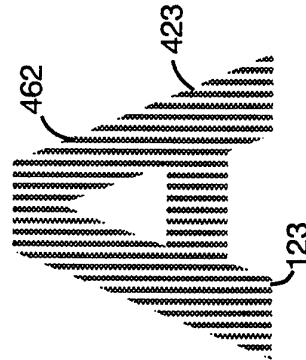

FIG-19

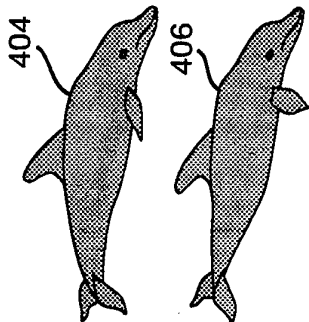

FIG-20

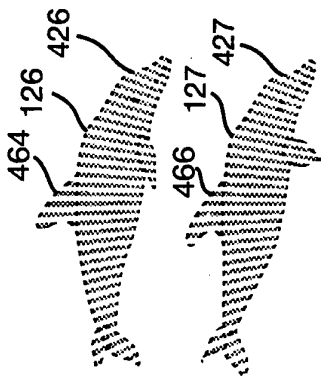

FIG-21

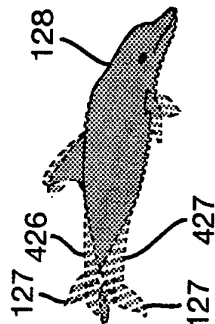

FIG-22

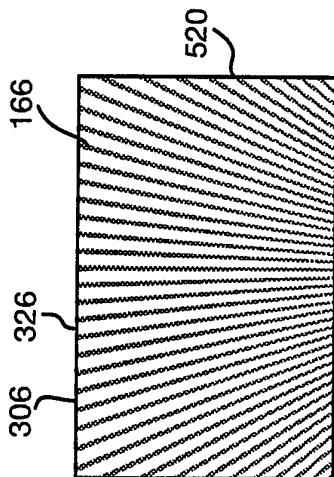

FIG-23

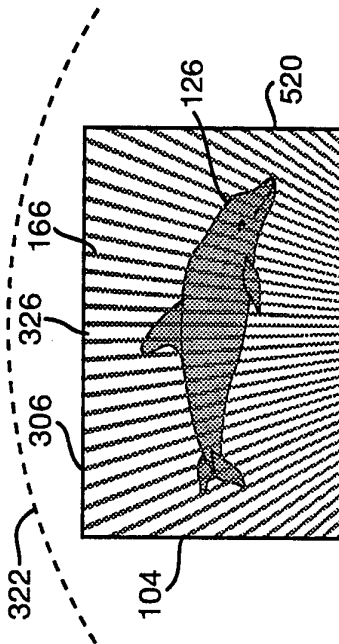
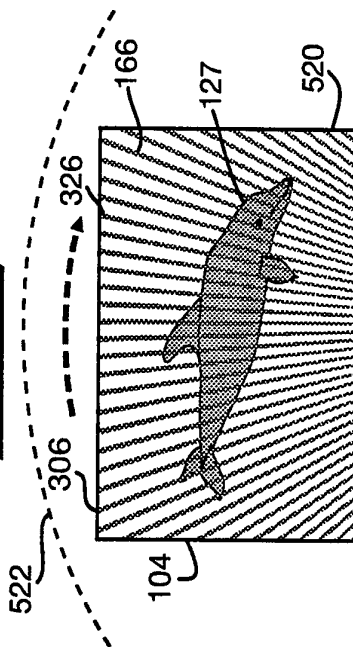
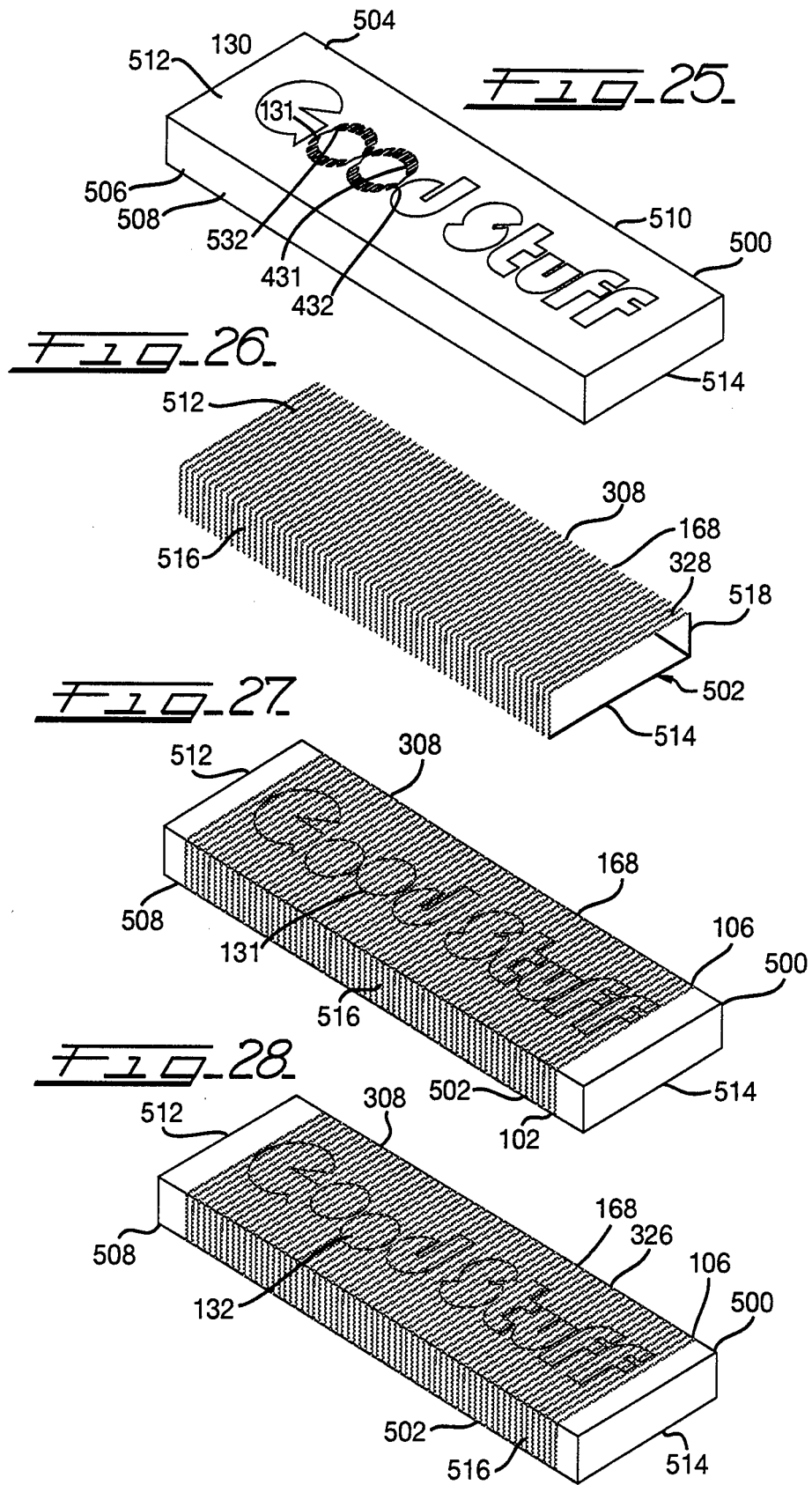
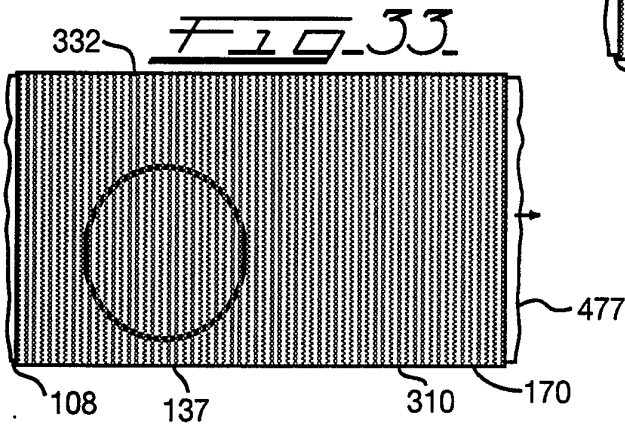
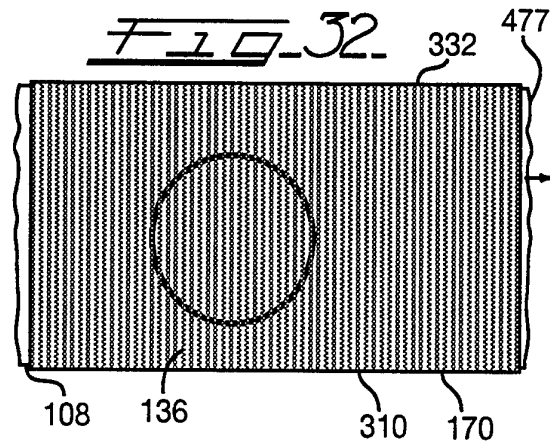
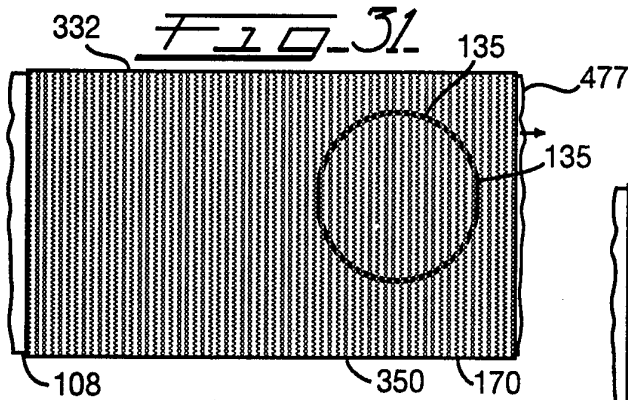
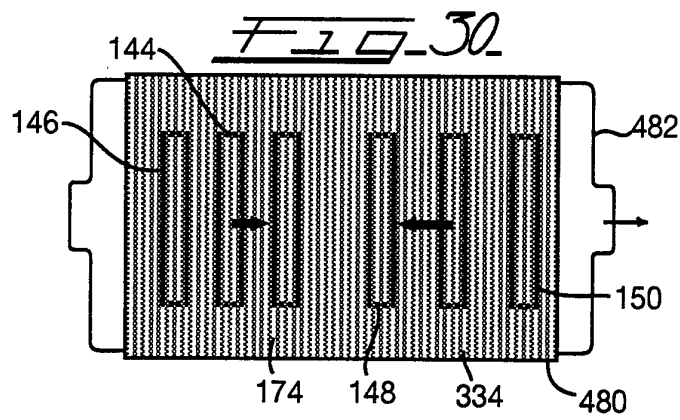
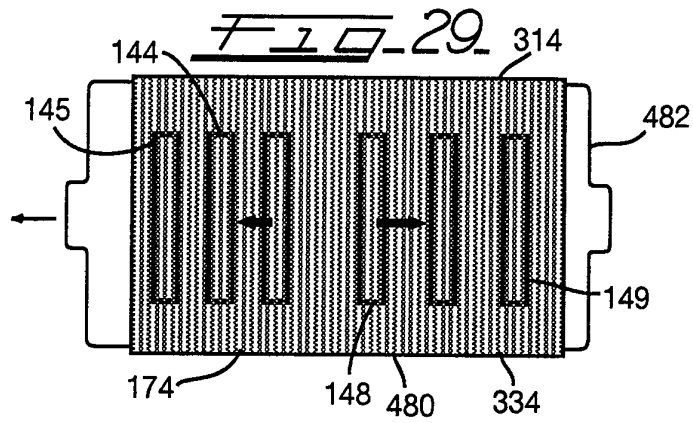

FIG-24



6/16





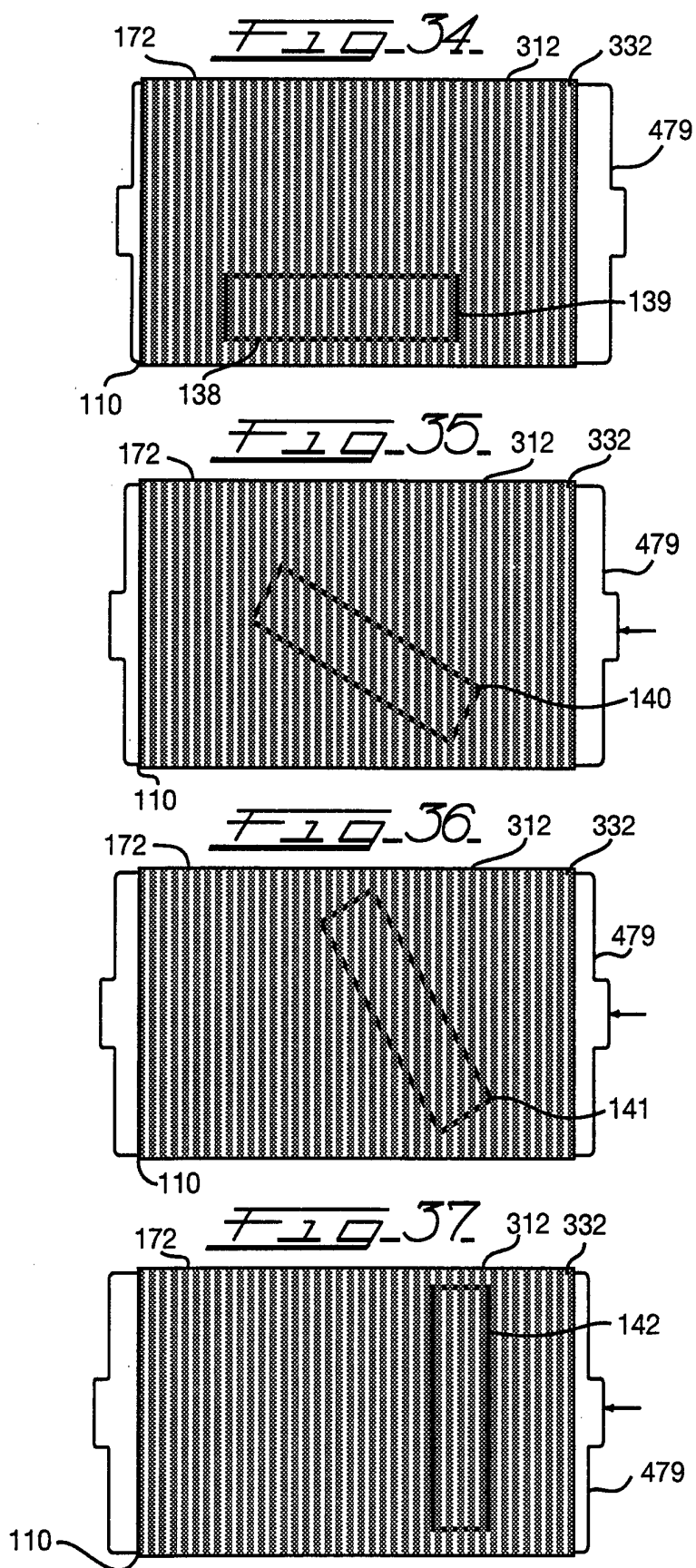

9/16

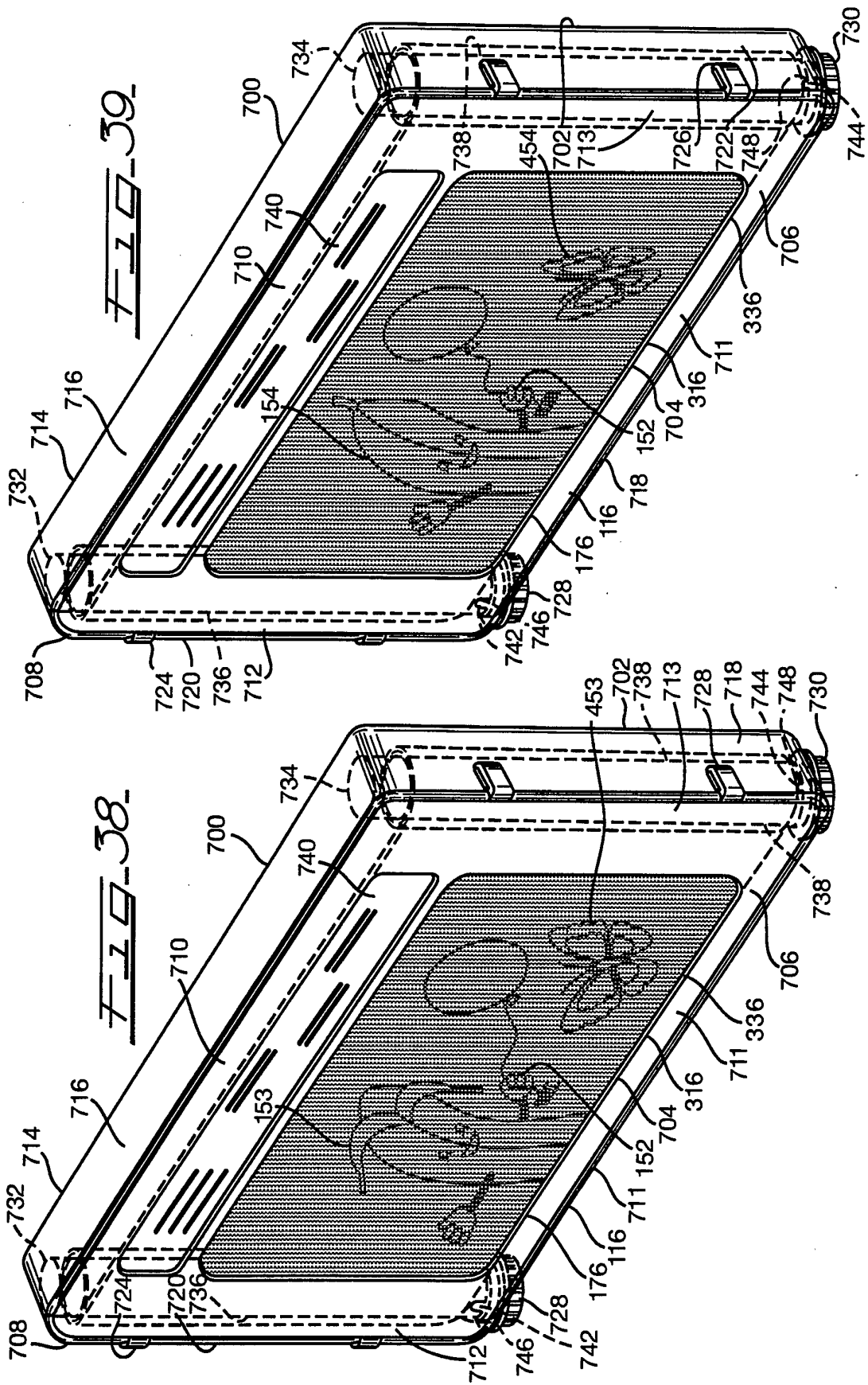

FIG. 40

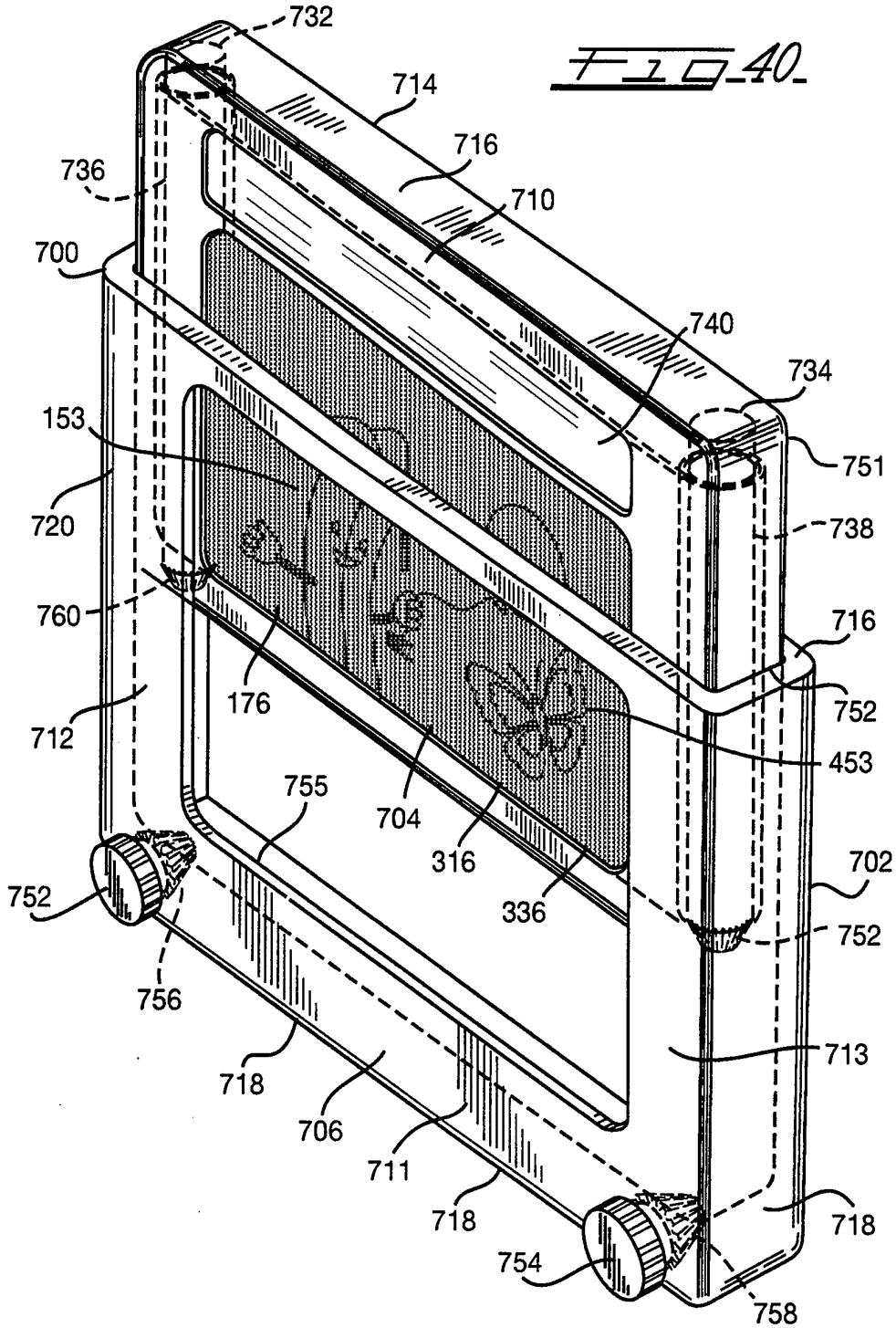

FIG. 41

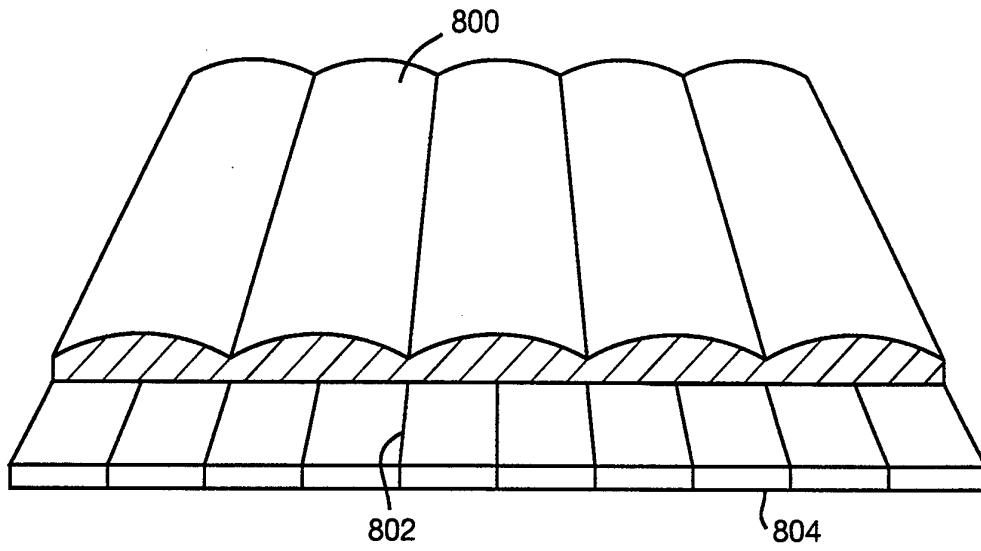

FIG. 42

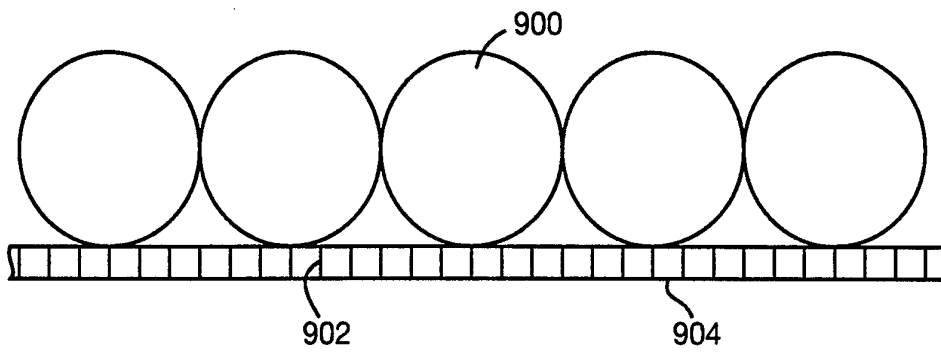

FIG-43a-

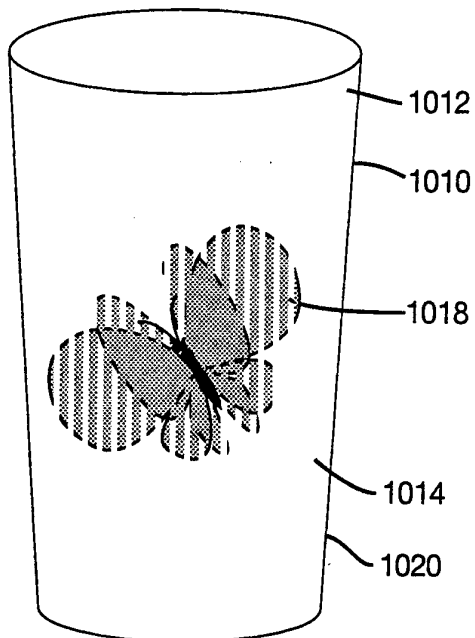

FIG-43b-

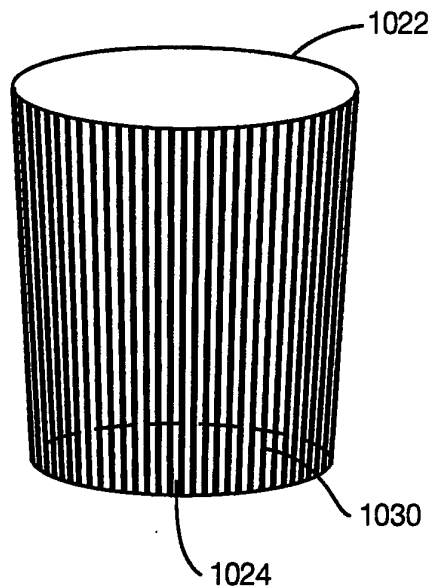

FIG-43c-

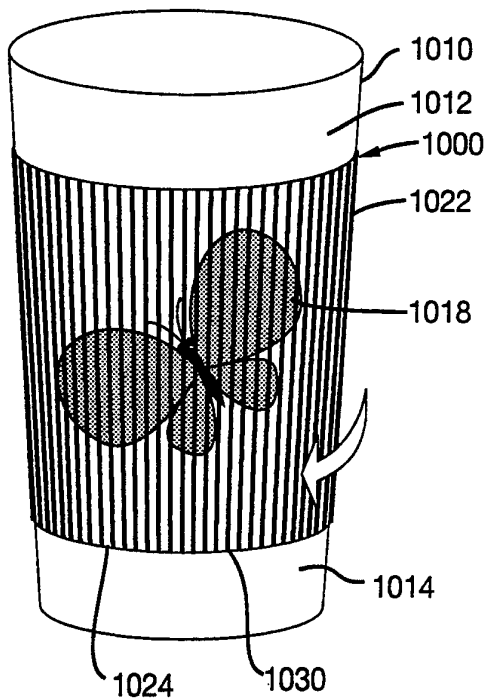

FIG-43d-

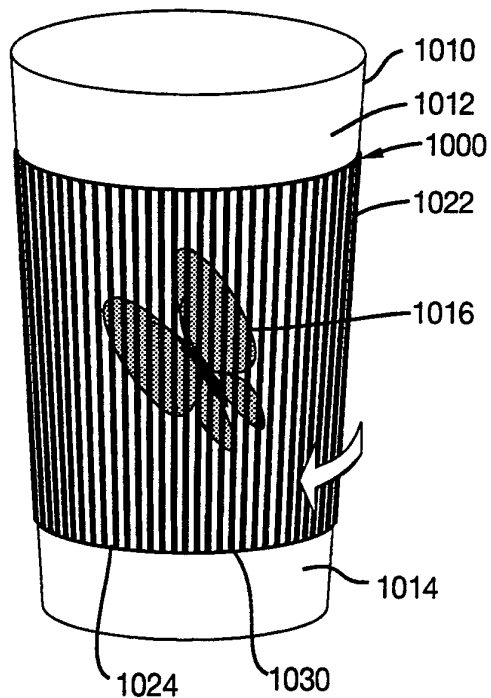

FIG. 43c.

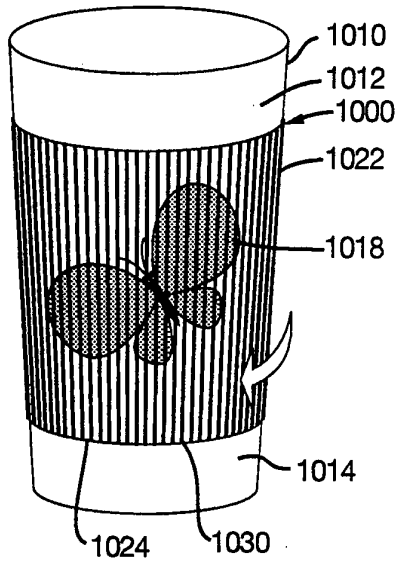

FIG. 44.

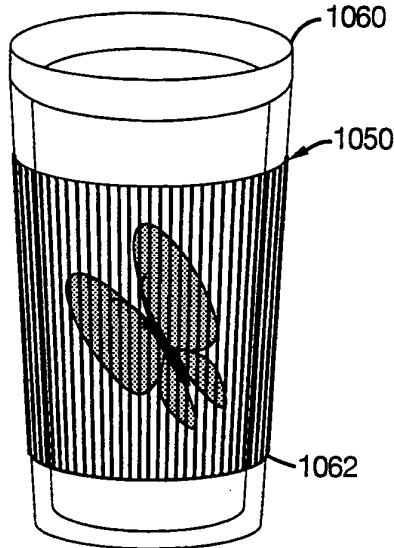

FIG. 45.

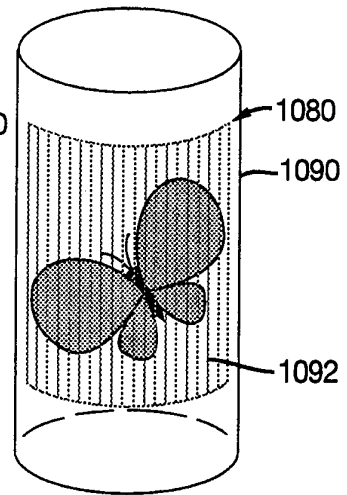

FIG. 46.

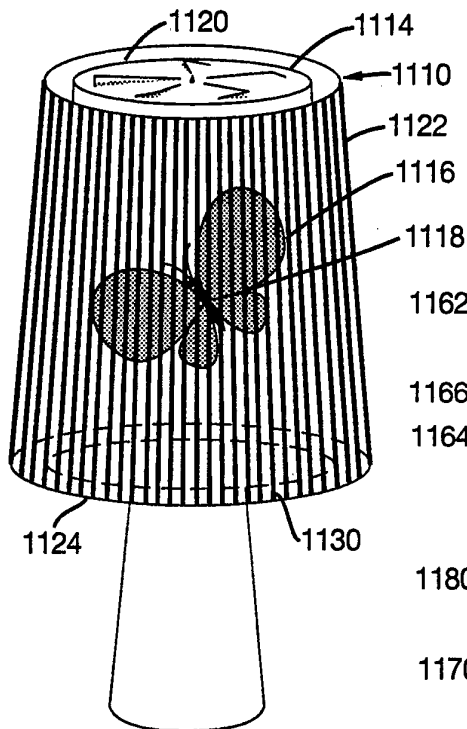

FIG. 47.

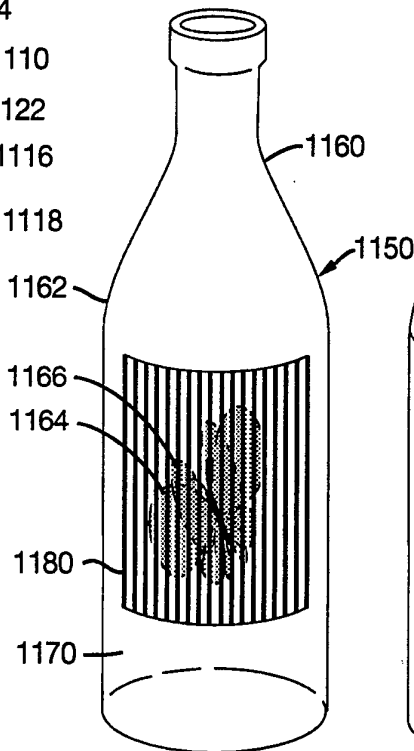
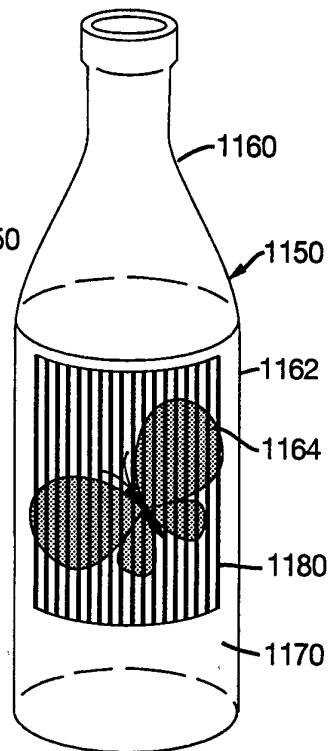

FIG. 48.



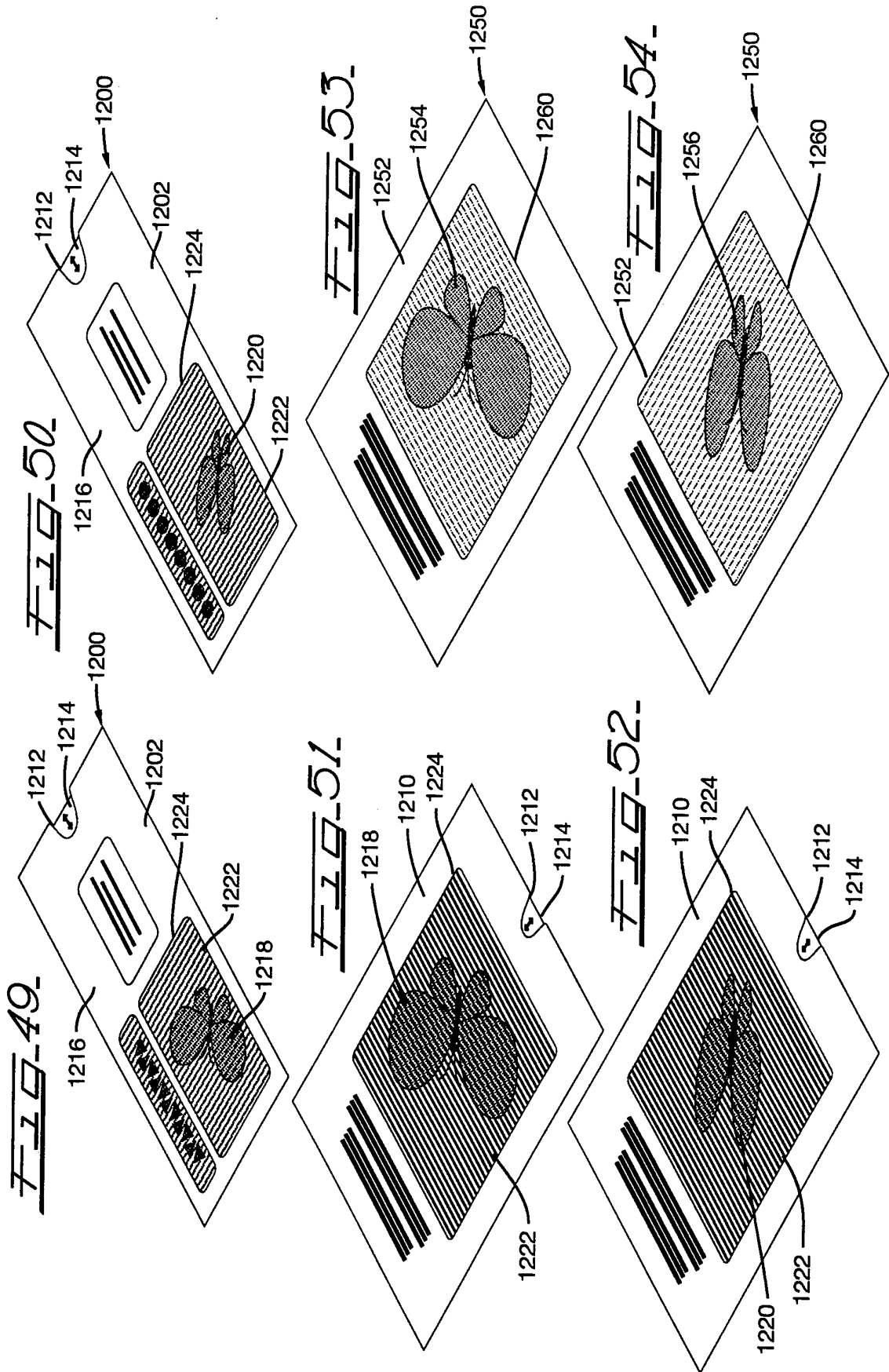

FIG. 55.

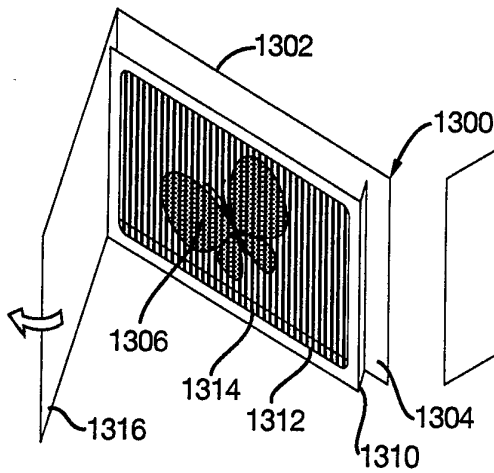

FIG. 56.

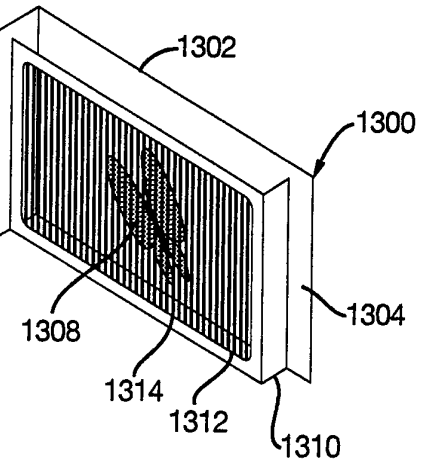

FIG. 57.

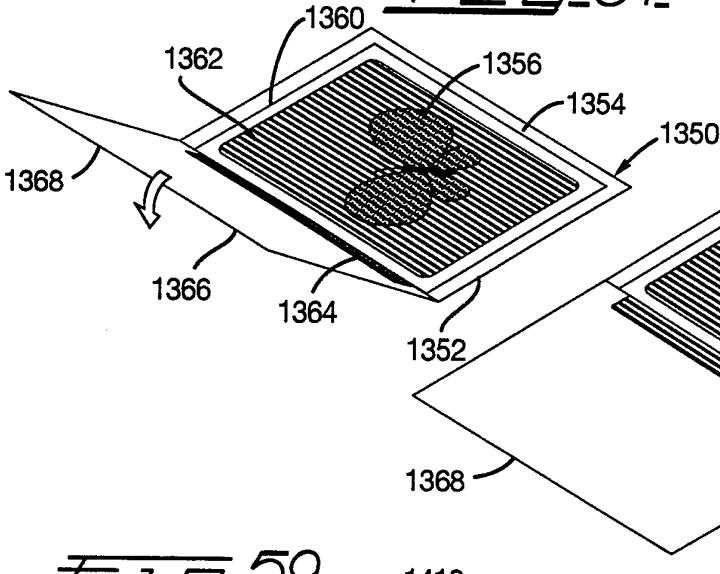

FIG. 58.

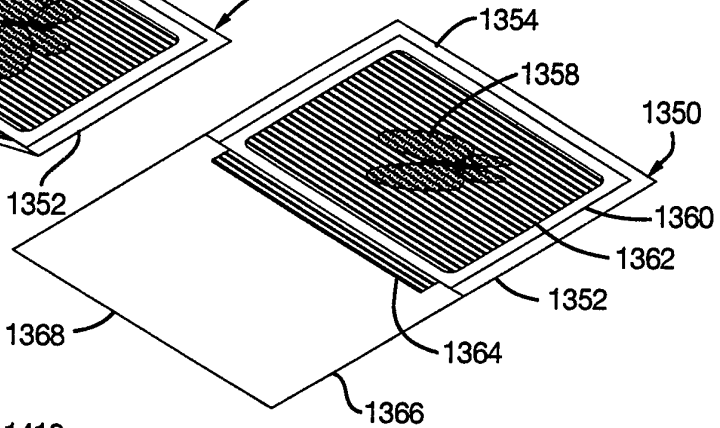

FIG. 59.

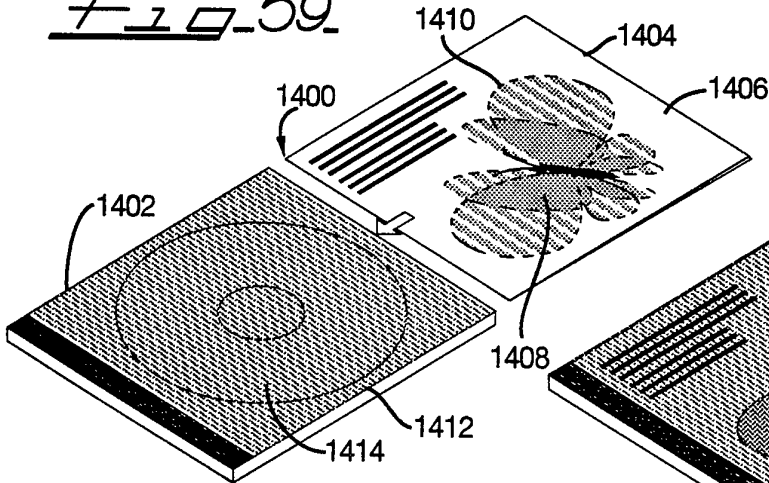
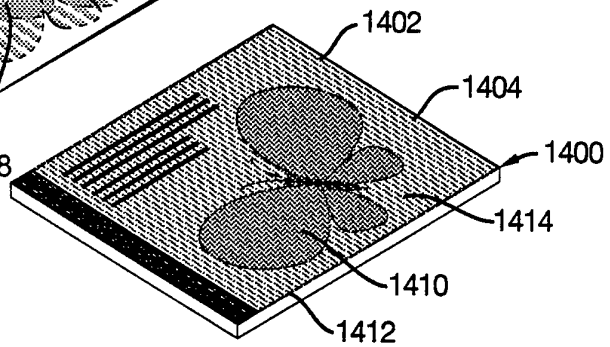
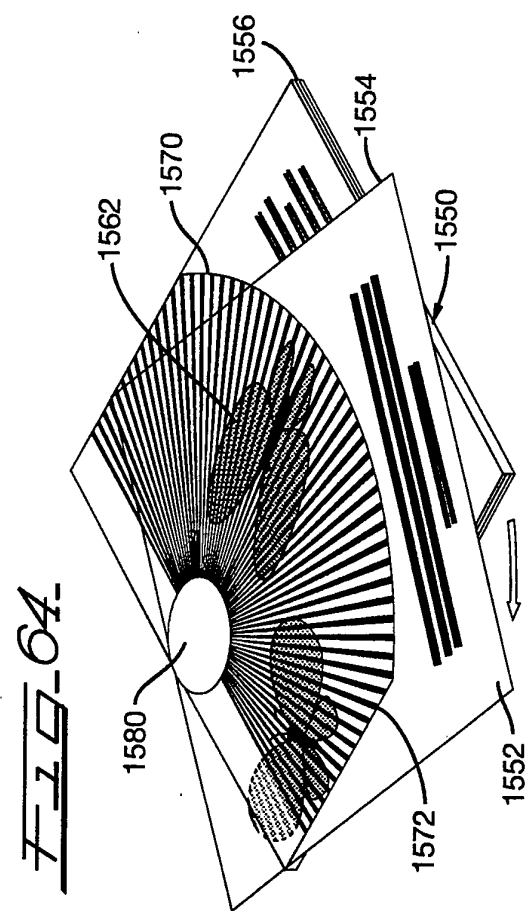
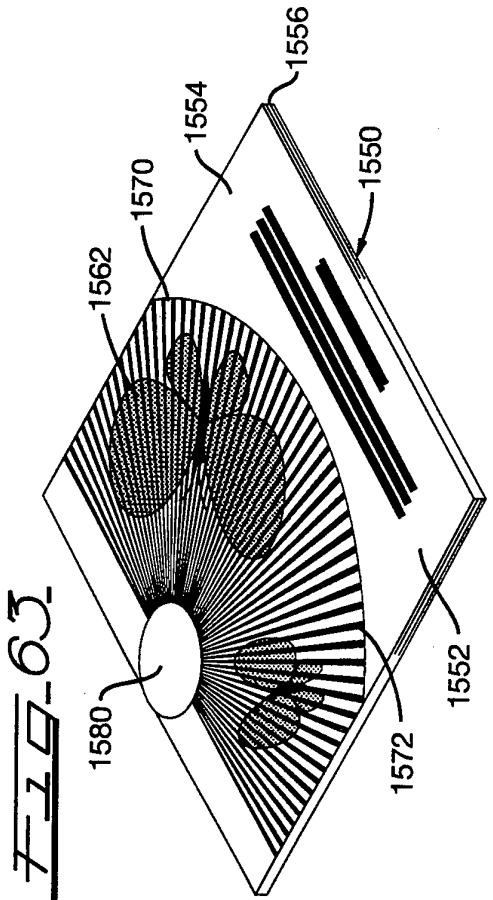
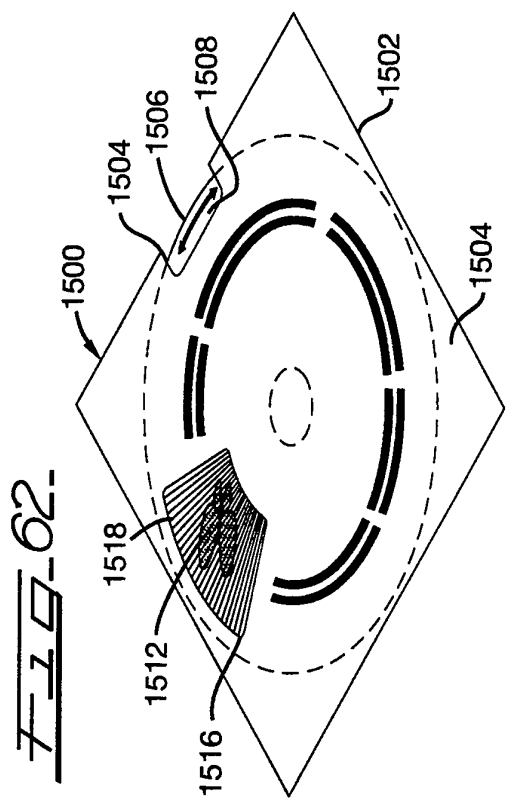
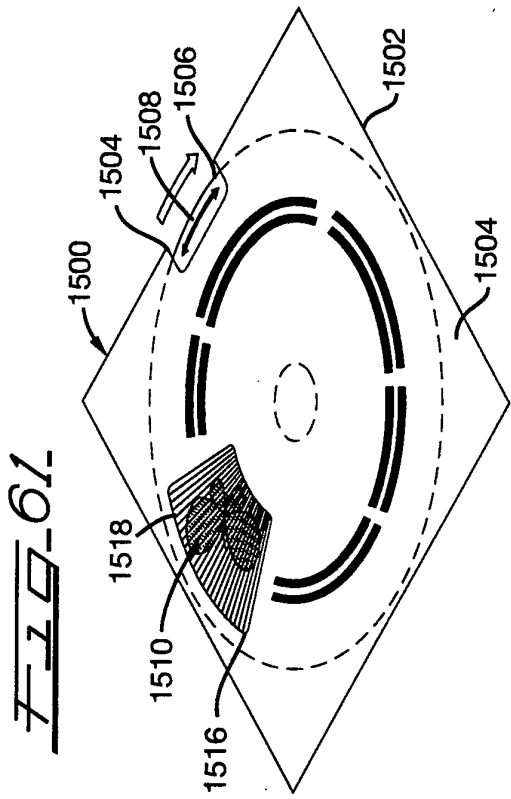

FIG. 60.





INTERNATIONAL SEARCH REPORT

International application No.
PCT/US94/07214

A. CLASSIFICATION OF SUBJECT MATTER IPC(5) :G09B 19/00 US CL :40/436, 453; 434/81, 365, 426 According to International Patent Classification (IPC) or to both national classification and IPC		
B. FIELDS SEARCHED Minimum documentation searched (classification system followed by classification symbols) U.S. : 40/436, 437, 442, 451-454; 434/81, 90, 96, 97, 365, 426, 428 Documentation searched other than minimum documentation to the extent that such documents are included in the fields searched NONE Electronic data base consulted during the international search (name of data base and, where practicable, search terms used) NONE		
C. DOCUMENTS CONSIDERED TO BE RELEVANT		
Category*	Citation of document, with indication, where appropriate, of the relevant passages	Relevant to claim No.
A	US, A, 4,897,802 (ATKINSON ET AL.), 30 January 1990. See entire document.	1-18
A	US, A, 4,263,737, (SIMON), 28 April 1991. See entire document.	1-18
A	US, A, 4,208,811, (JUNOWICZ), 24 June 1980. See entire document.	1-18
<input type="checkbox"/> Further documents are listed in the continuation of Box C. <input type="checkbox"/> See patent family annex.		
* Special categories of cited documents:	"T"	later document published after the international filing date or priority date and not in conflict with the application but cited to understand the principle or theory underlying the invention
"A" document defining the general state of the art which is not considered to be part of particular relevance	"X"	document of particular relevance; the claimed invention cannot be considered novel or cannot be considered to involve an inventive step when the document is taken alone
"E" earlier document published on or after the international filing date	"Y"	document of particular relevance; the claimed invention cannot be considered to involve an inventive step when the document is combined with one or more other such documents, such combination being obvious to a person skilled in the art
"L" document which may throw doubts on priority claim(s) or which is cited to establish the publication date of another citation or other special reason (as specified)	"&"	document member of the same patent family
"O" document referring to an oral disclosure, use, exhibition or other means		
"P" document published prior to the international filing date but later than the priority date claimed		
Date of the actual completion of the international search 03 NOVEMBER 1994	Date of mailing of the international search report DEC 06 1994	
Name and mailing address of the ISA/US Commissioner of Patents and Trademarks Box PCT Washington, D.C. 20231 Facsimile No. (703) 305-3230	Authorized officer GLENN RICHMAN Telephone No. (703) 308-3170	