



US009033818B2

(12) **United States Patent**  
**Myrhum et al.**

(10) **Patent No.:** **US 9,033,818 B2**

(45) **Date of Patent:** **May 19, 2015**

(54) **GOLF CLUB HEAD HAVING A MULTI-MATERIAL FACE**

USPC ..... 473/324-350, 287-292  
See application file for complete search history.

(75) Inventors: **Mark C. Myrhum**, Del Mar, CA (US);  
**Uday V. Deshmukh**, Carlsbad, CA (US)

(56) **References Cited**

U.S. PATENT DOCUMENTS

(73) Assignee: **Acushnet Company**, Fairhaven, MA (US)

700,946	A *	5/1902	Kempshall	473/329
819,900	A *	5/1906	Martin	473/329
4,681,322	A	7/1987	Straza et al.	
5,058,895	A	10/1991	Igarashi	
5,163,682	A	11/1992	Schmidt et al.	
5,238,529	A	8/1993	Douglas	
5,310,185	A	5/1994	Viollaz et al.	
5,346,216	A *	9/1994	Aizawa	473/329
5,358,249	A	10/1994	Mendralla	
5,362,055	A	11/1994	Rennie	
5,403,007	A	4/1995	Chen	
5,405,136	A	4/1995	Hardman	
5,425,538	A	6/1995	Vincent et al.	
5,524,331	A	6/1996	Pond	
5,720,673	A	2/1998	Anderson	
5,743,813	A	4/1998	Chen et al.	
5,827,131	A *	10/1998	Mahaffey et al.	473/342

(\* ) Notice: Subject to any disclaimer, the term of this patent is extended or adjusted under 35 U.S.C. 154(b) by 169 days.

(21) Appl. No.: **13/558,421**

(22) Filed: **Jul. 26, 2012**

(65) **Prior Publication Data**

US 2012/0289363 A1 Nov. 15, 2012

**Related U.S. Application Data**

(63) Continuation-in-part of application No. 12/916,760, filed on Nov. 1, 2010, now Pat. No. 8,517,859, which is a continuation-in-part of application No. 12/832,461, filed on Jul. 8, 2010, now Pat. No. 8,221,261.

FOREIGN PATENT DOCUMENTS

JP H05-7261 2/1993

OTHER PUBLICATIONS

The Royal and Ancient Golf Club of St. Andrews and USGA, Technical Description of the Pendulum Test revised version, Nov. 2003.

(51) **Int. Cl.**  
**A63B 53/04** (2006.01)

*Primary Examiner* — Sebastiano Passaniti

(52) **U.S. Cl.**  
CPC ..... **A63B 53/0466** (2013.01); **A63B 2053/0433** (2013.01); **A63B 2053/0458** (2013.01); **A63B 2209/02** (2013.01); **A63B 2053/0408** (2013.01); **A63B 2053/042** (2013.01); **A63B 2053/0462** (2013.01)

(74) *Attorney, Agent, or Firm* — Mandi B. Milbank

(57) **ABSTRACT**

(58) **Field of Classification Search**  
CPC ..... A63B 53/0466; A63B 2053/0433; A63B 2053/0458; A63B 2209/02; A63B 2053/0408; A63B 2053/042; A63B 2053/0462

A golf club head with a multi-material face is disclosed herein. The layers of the multi-material face are preferably attached to the club head using adhesive and mechanical methods.

**6 Claims, 26 Drawing Sheets**

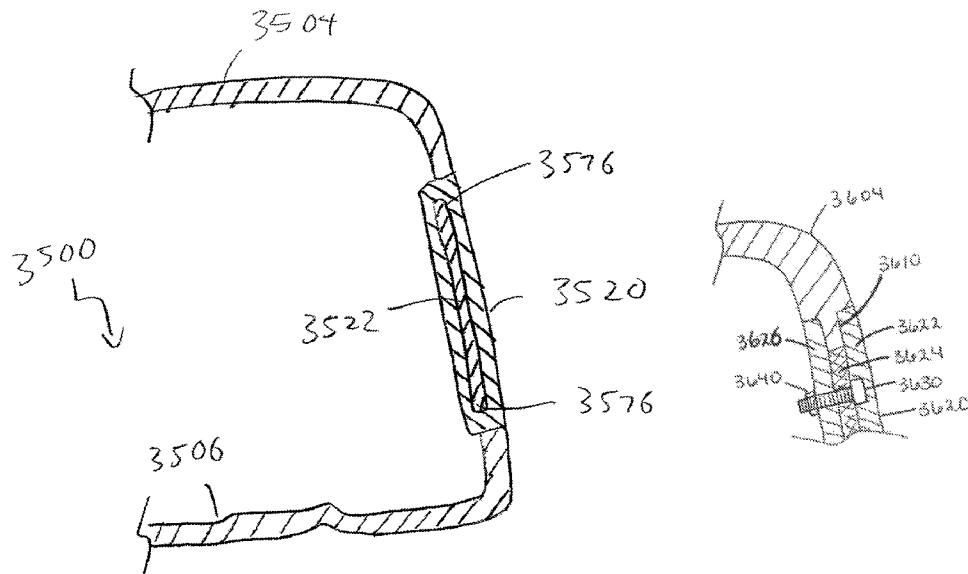

(56)

References Cited

U.S. PATENT DOCUMENTS

5,967,903 A	10/1999	Cheng		7,267,620 B2	9/2007	Chao et al.	
6,074,309 A *	6/2000	Mahaffey .....	473/342	7,281,994 B2	10/2007	De Shiell et al.	
6,364,789 B1 *	4/2002	Kosmatka .....	473/329	7,331,877 B2	2/2008	Yamaguchi et al.	
6,440,008 B2	8/2002	Murphy et al.		7,384,348 B2 *	6/2008	Lin et al. ....	473/332
6,623,543 B1	9/2003	Zeller et al.		7,399,238 B2	7/2008	Hocknell et al.	
6,672,975 B1 *	1/2004	Galloway .....	473/342	7,628,712 B2	12/2009	Chao et al.	
6,837,094 B2	1/2005	Pringle et al.		2001/0051549 A1	12/2001	Inoue et al.	
6,986,715 B2 *	1/2006	Mahaffey .....	473/305	2006/0229141 A1	10/2006	Galloway	
7,140,974 B2	11/2006	Chao et al.		2008/0004131 A1 *	1/2008	Lin et al. ....	473/342
				2008/0293511 A1 *	11/2008	Gilbert .....	473/331
				2008/0300068 A1	12/2008	Chao	

\* cited by examiner

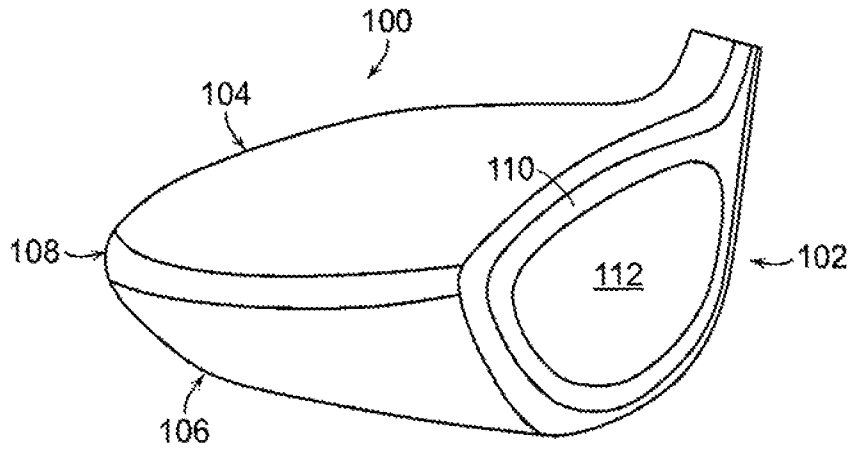

FIG. 1

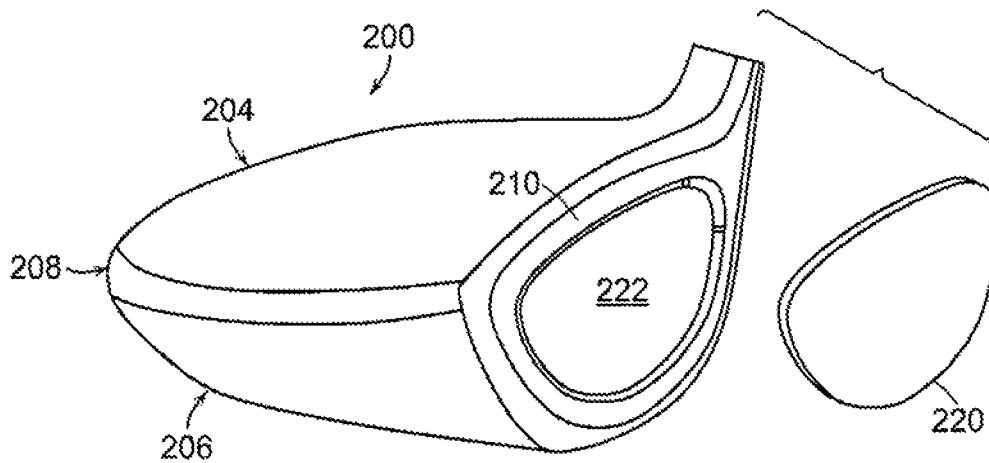

FIG. 2

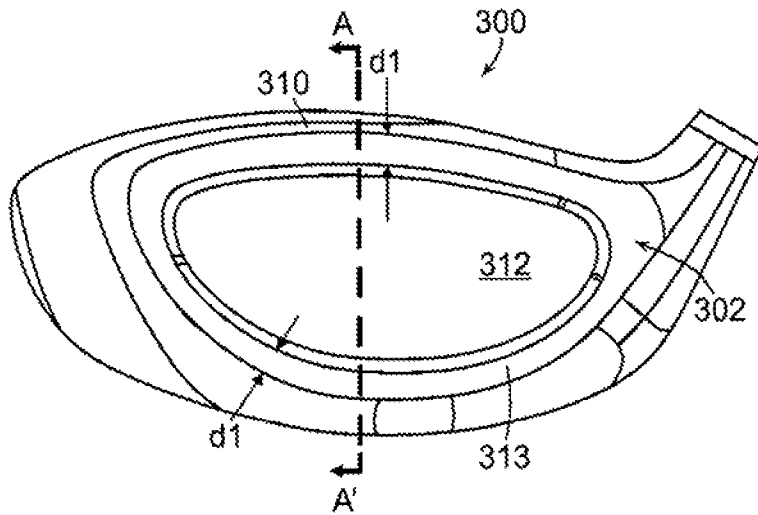

FIG. 3

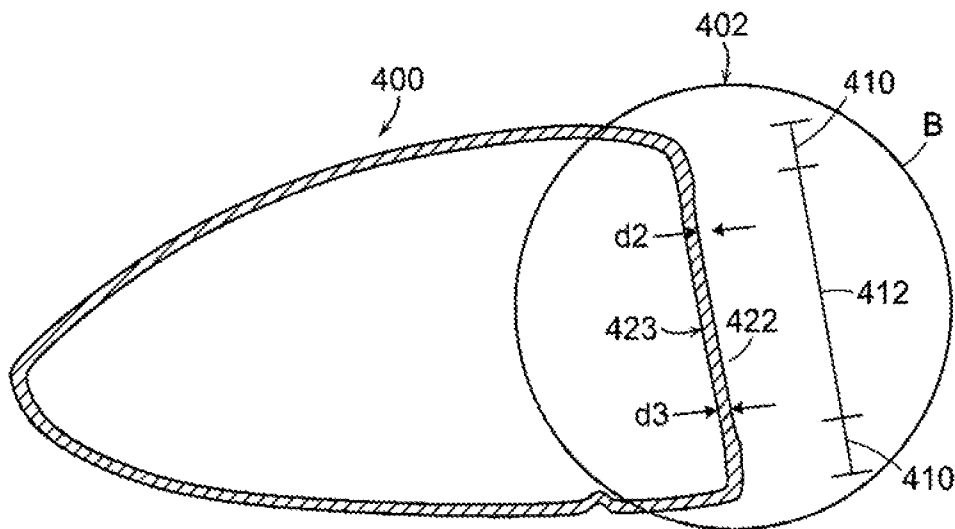

FIG. 4

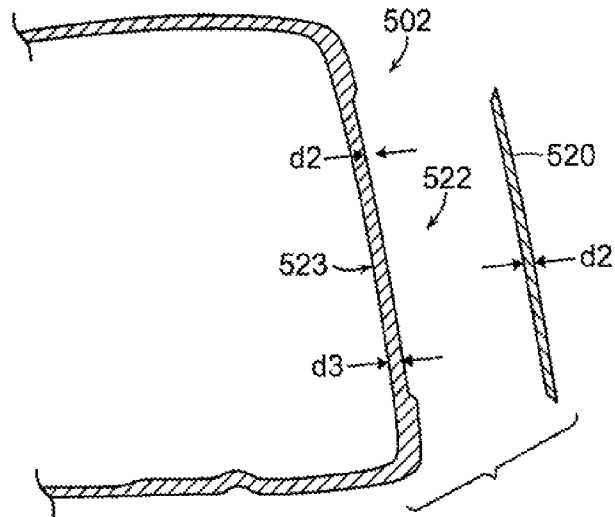

FIG. 5

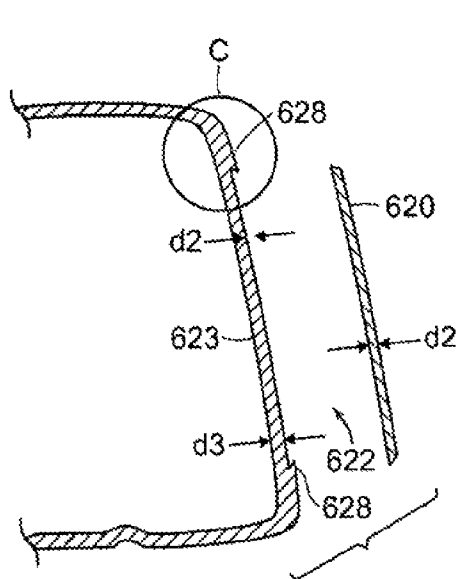

FIG. 6

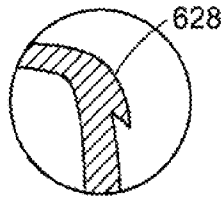

FIG. 6A

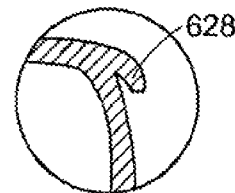

FIG. 6B

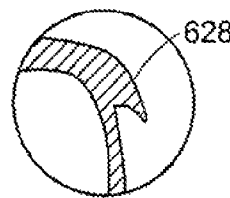

FIG. 6C

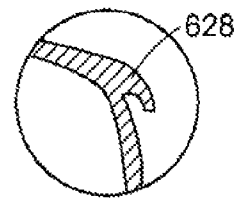

FIG. 6D

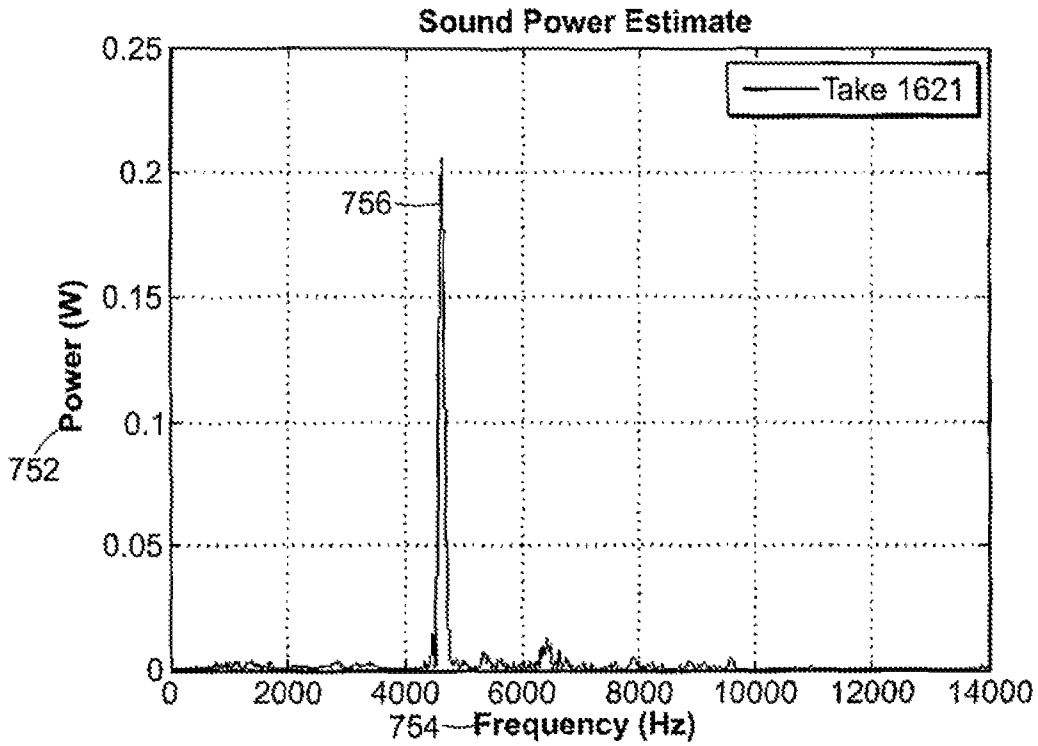

FIG. 7 (Prior Art)

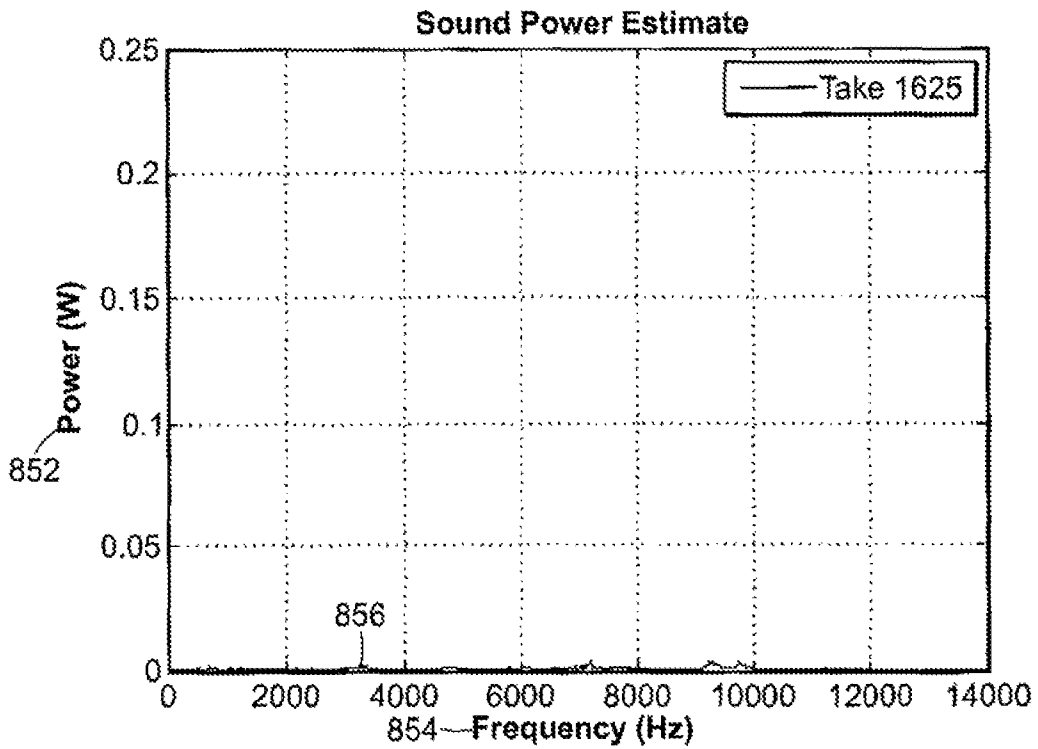

FIG. 8 (Prior Art)

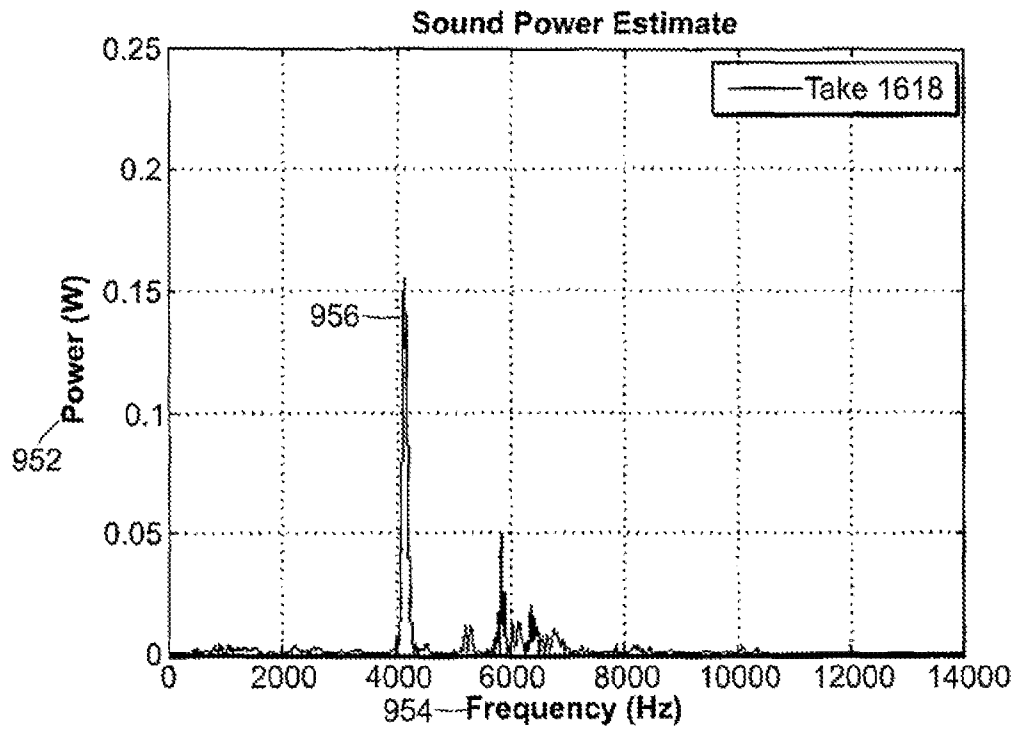

FIG. 9

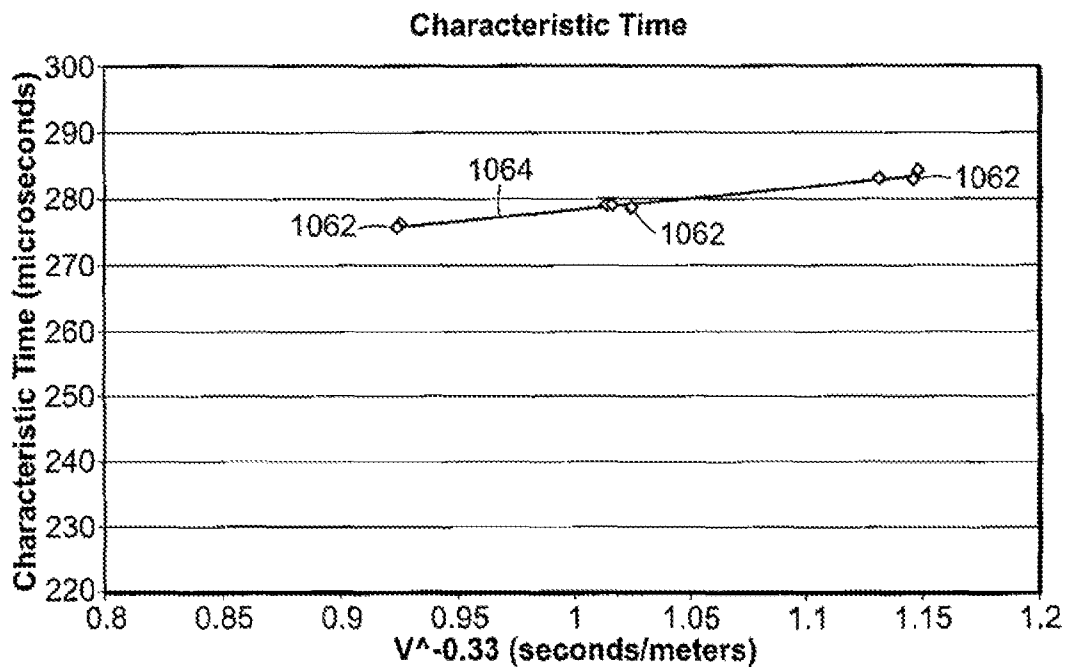

FIG. 10

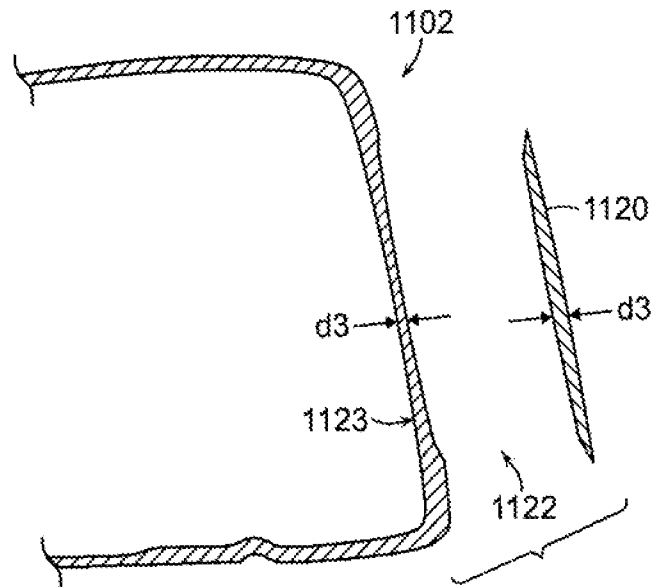

FIG. 11

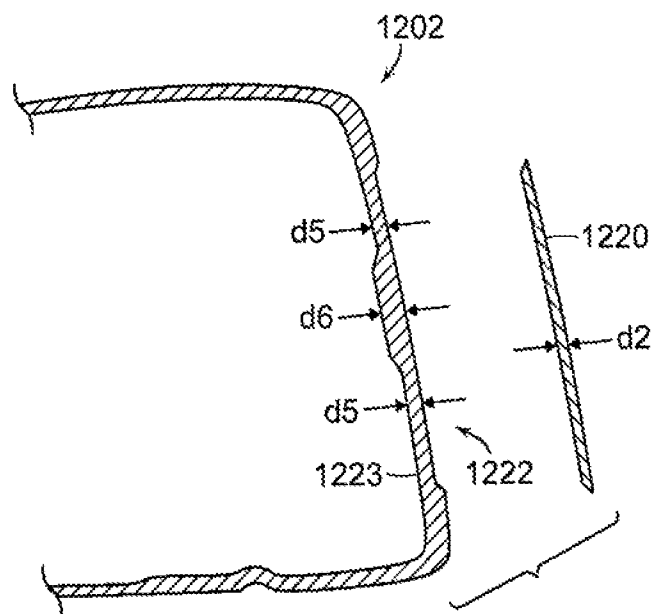

FIG. 12



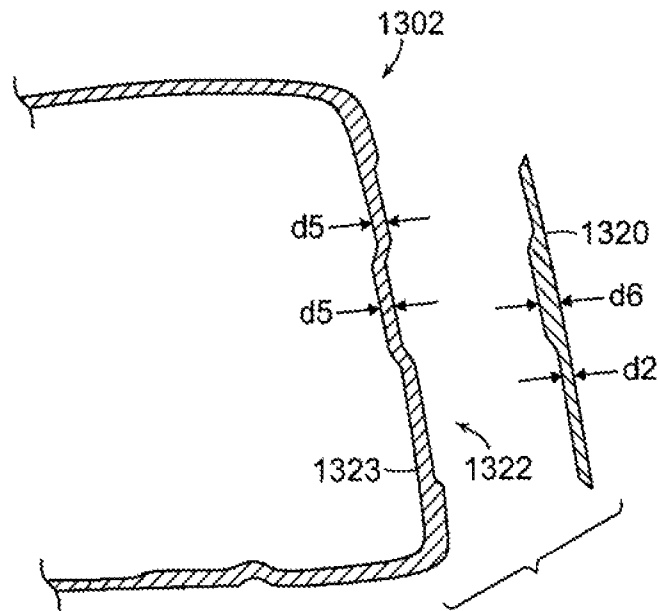

FIG. 13

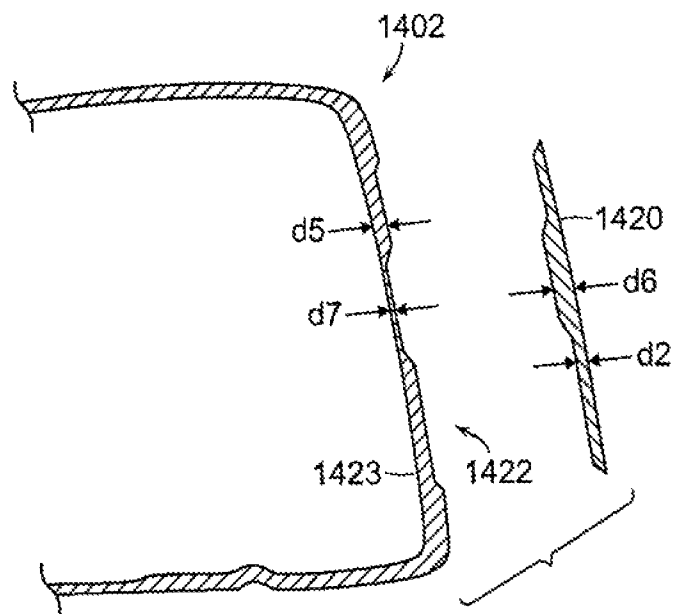

FIG. 14

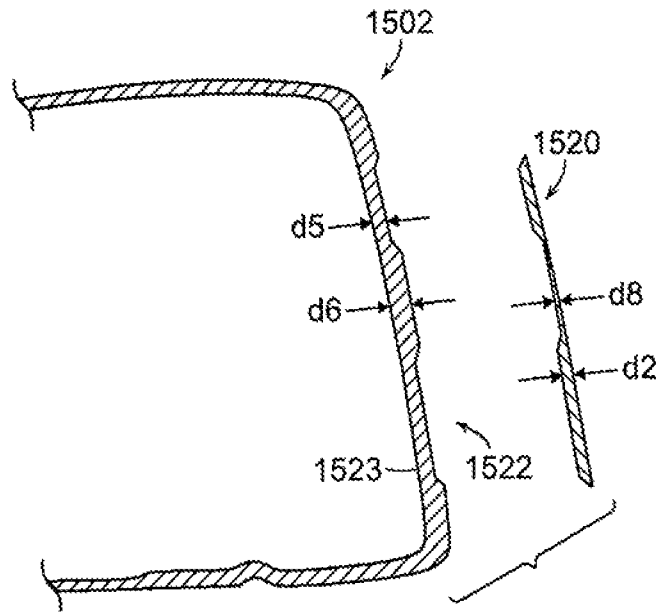

FIG. 15

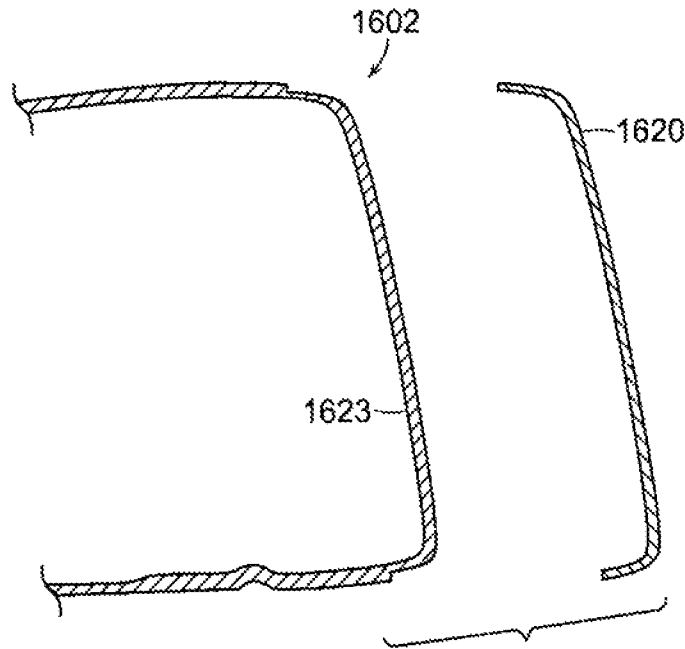

FIG. 16

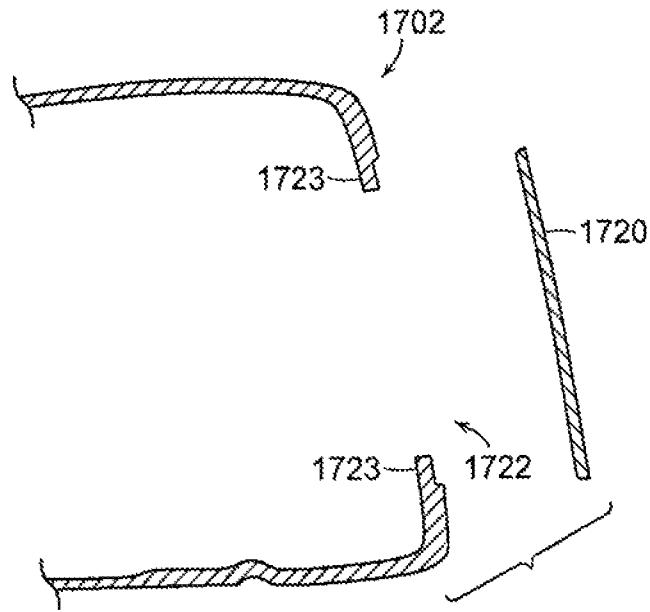

FIG. 17

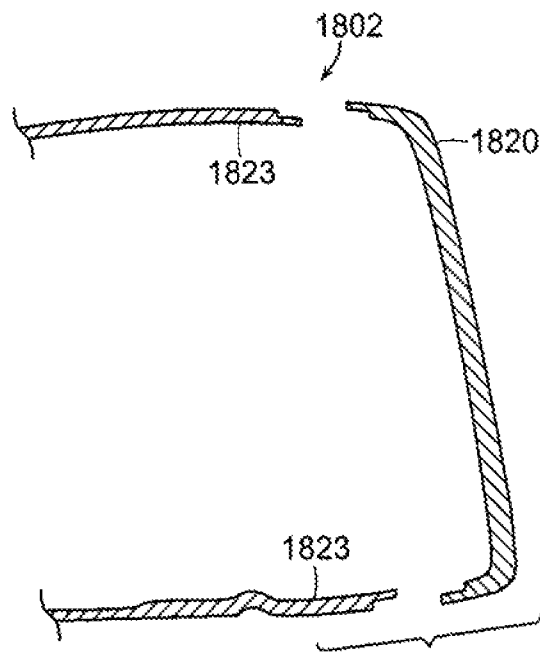

FIG. 18

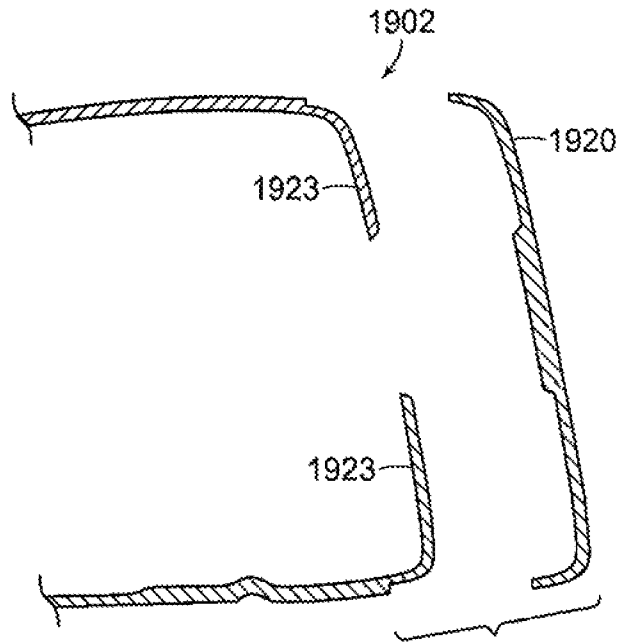

FIG. 19

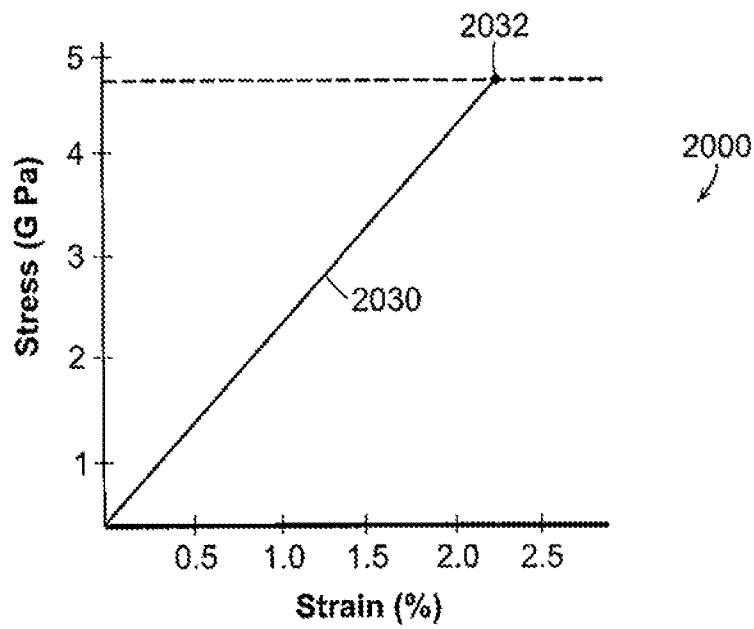

FIG. 20

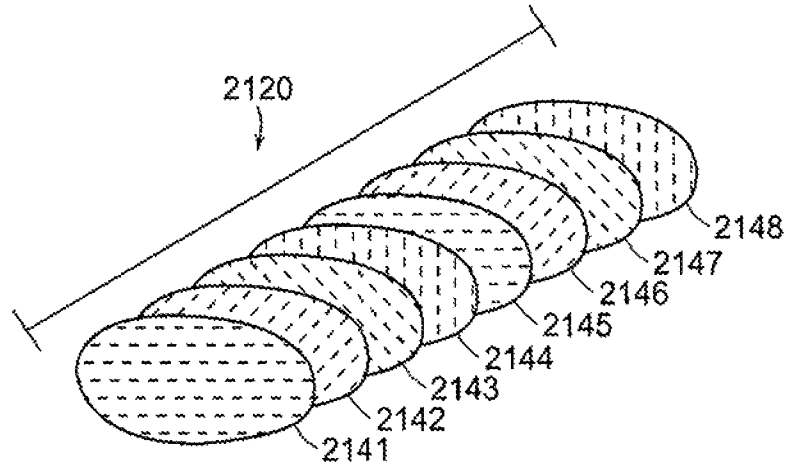

FIG. 21

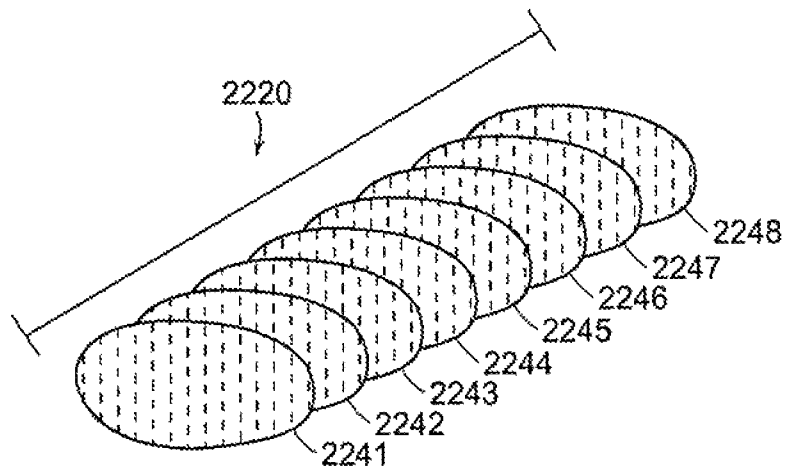

FIG. 22

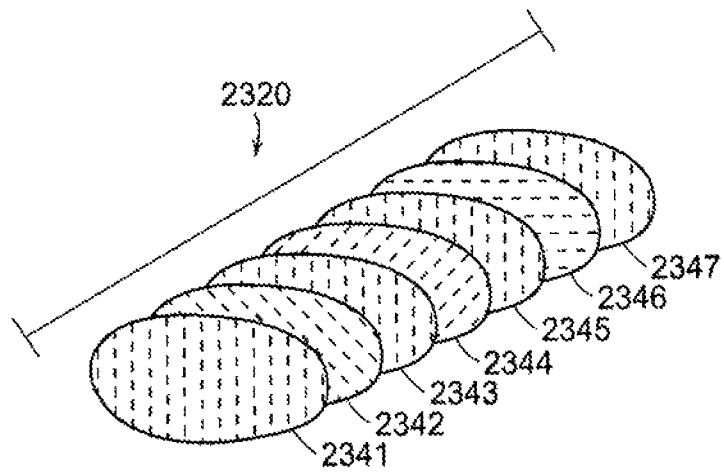

FIG. 23

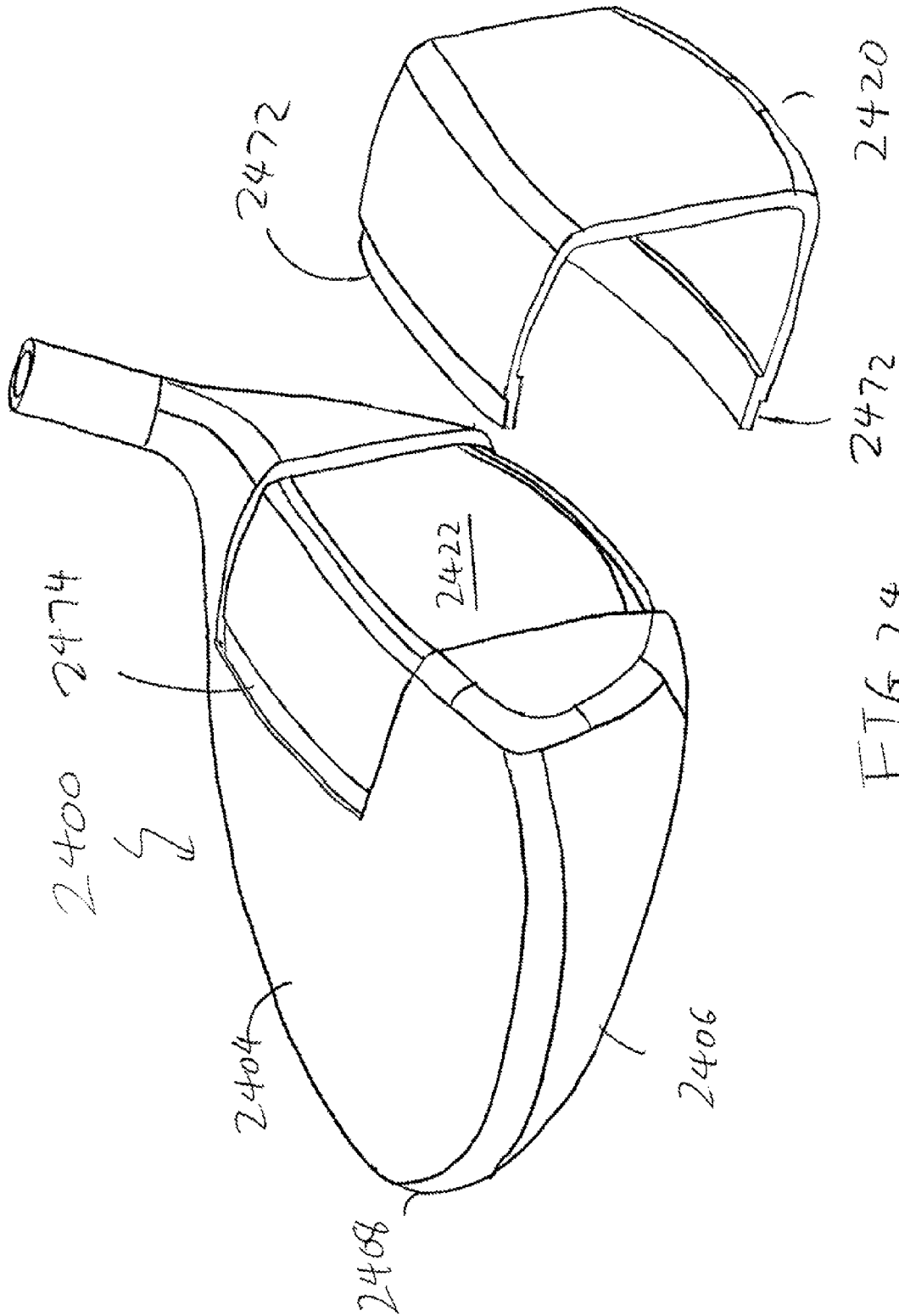

FIG. 24

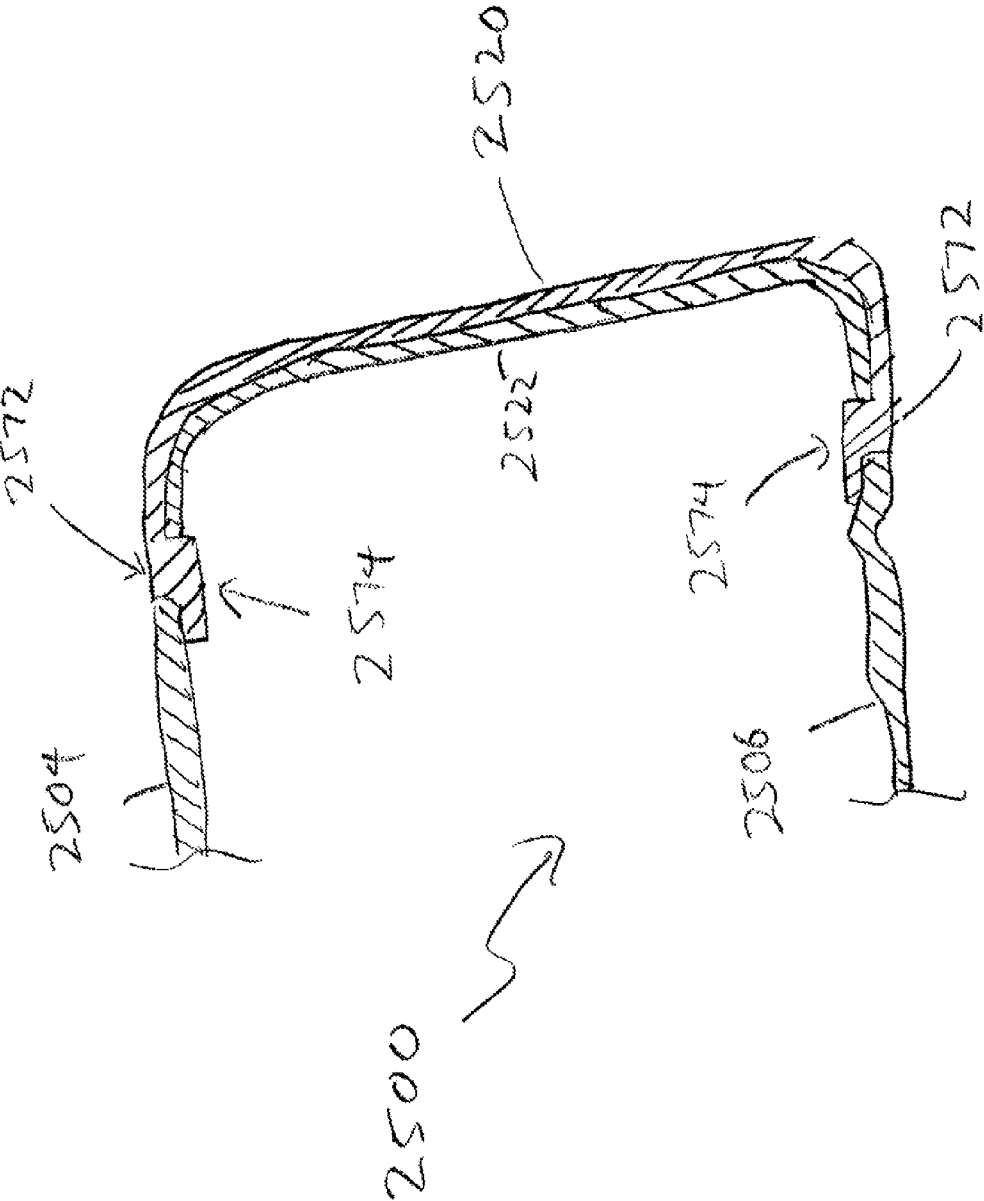

FIG. 25



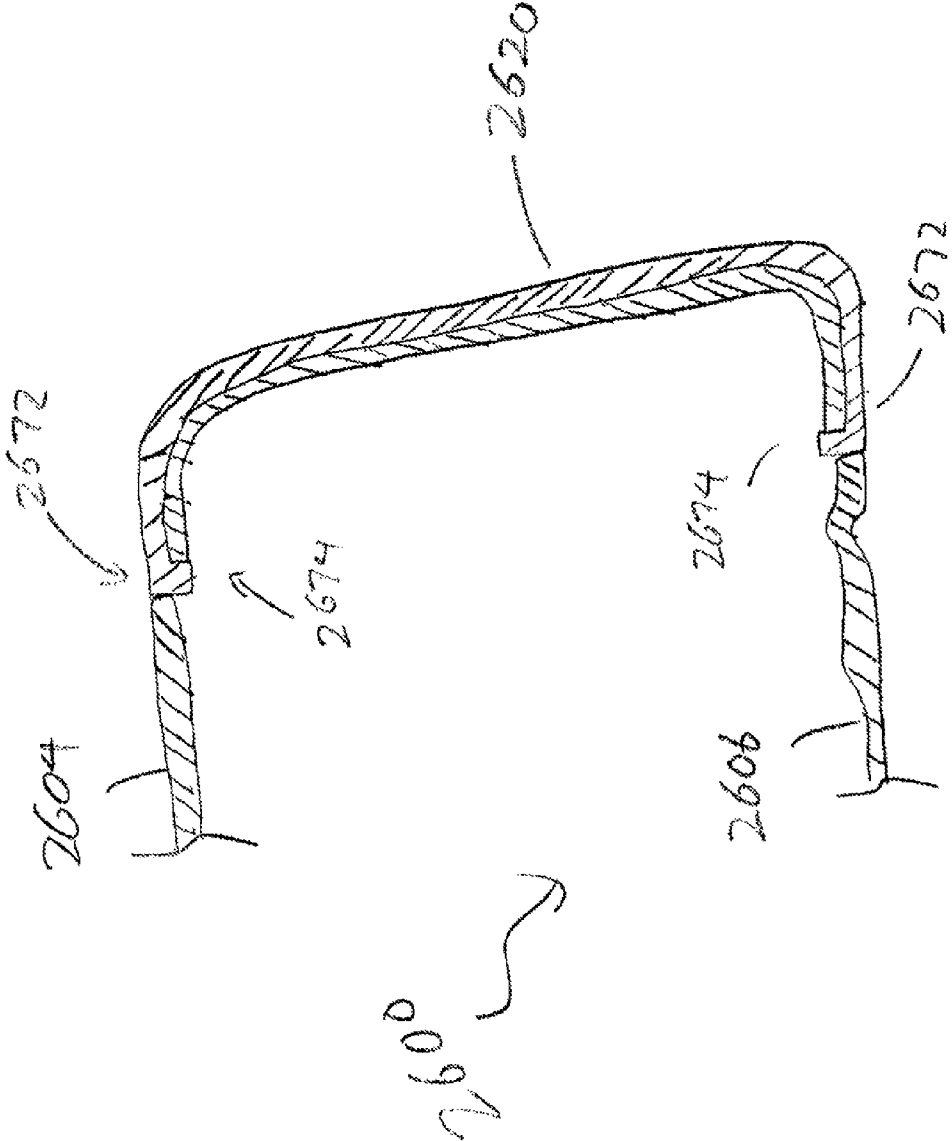

FIG 26

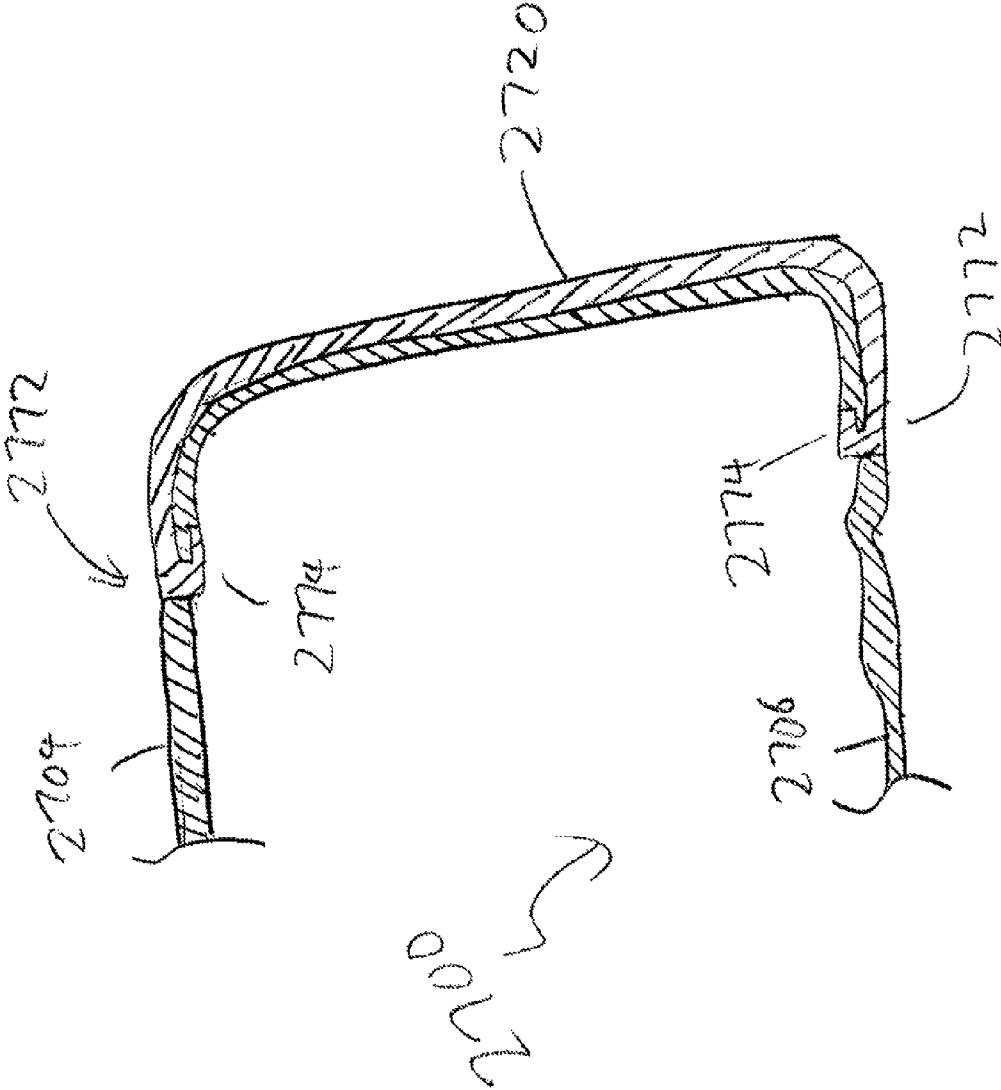

FIG. 27

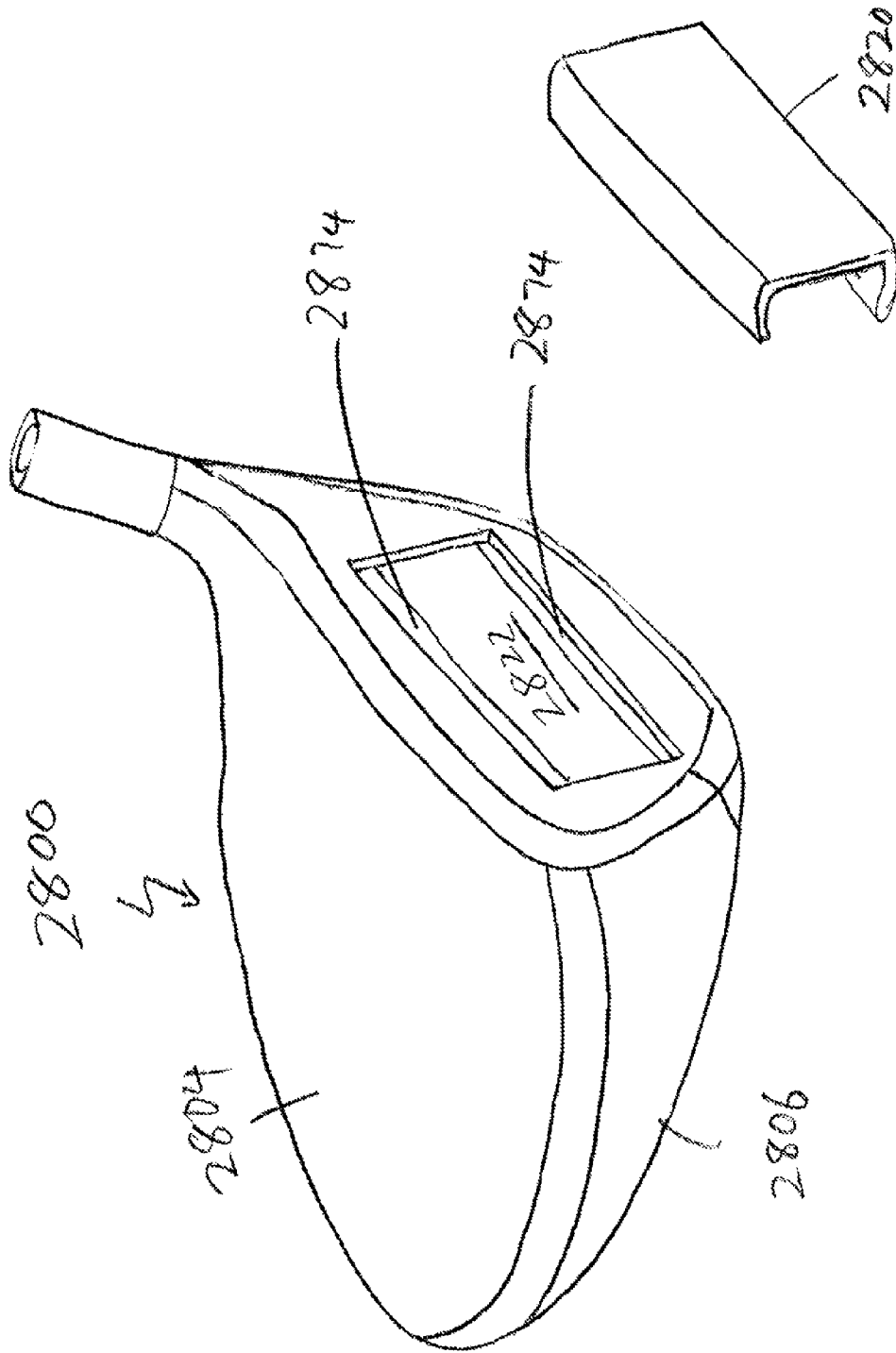

FIG. 28

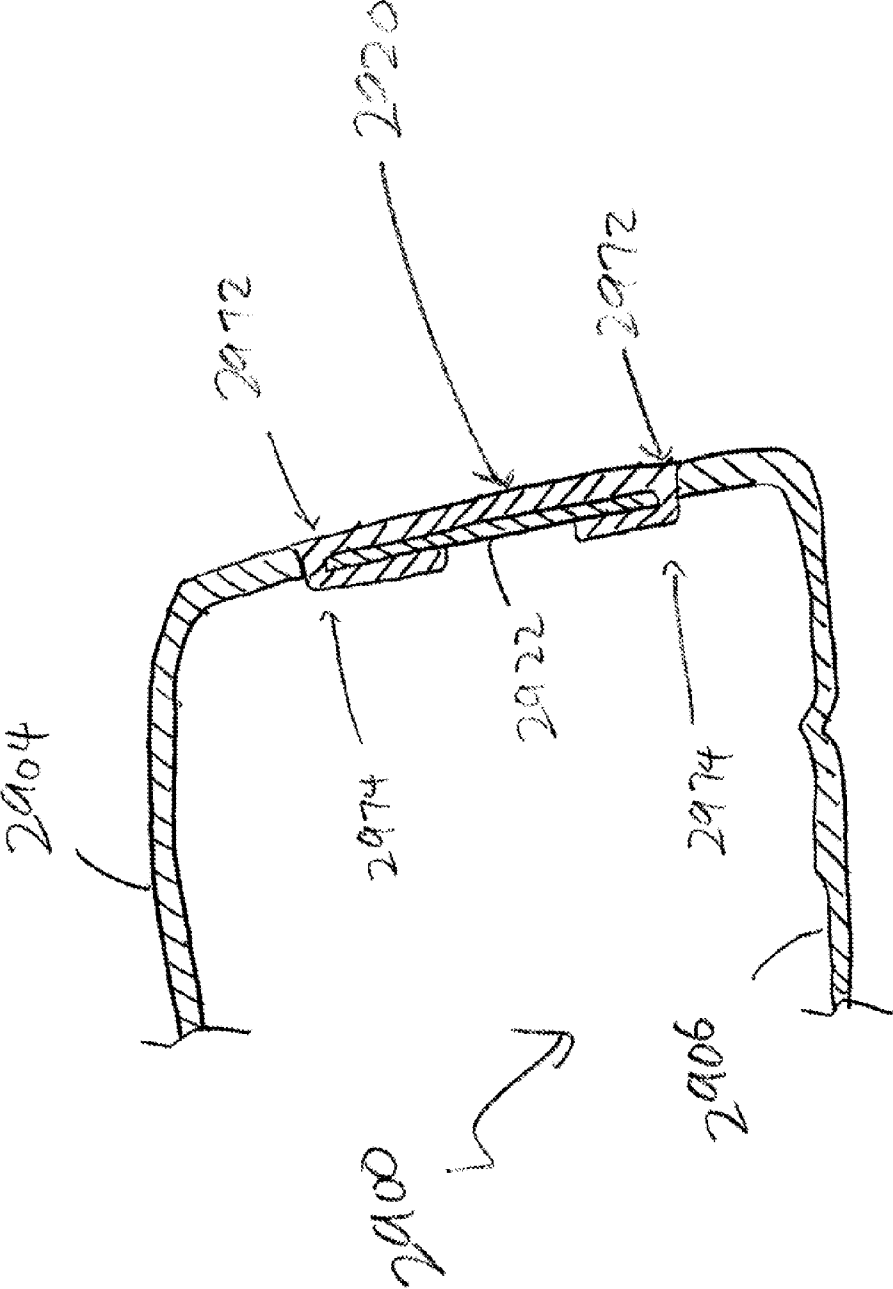

FIG. 29



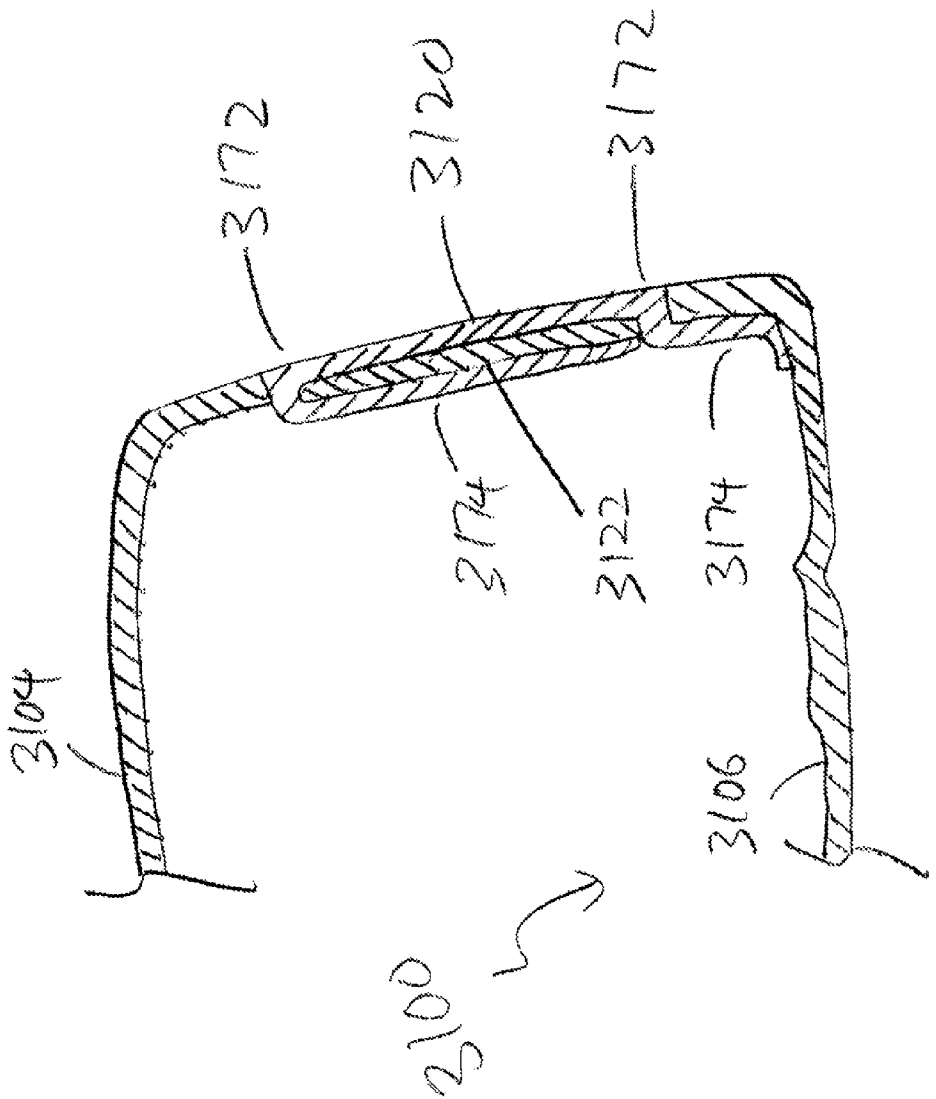

FIG. 31

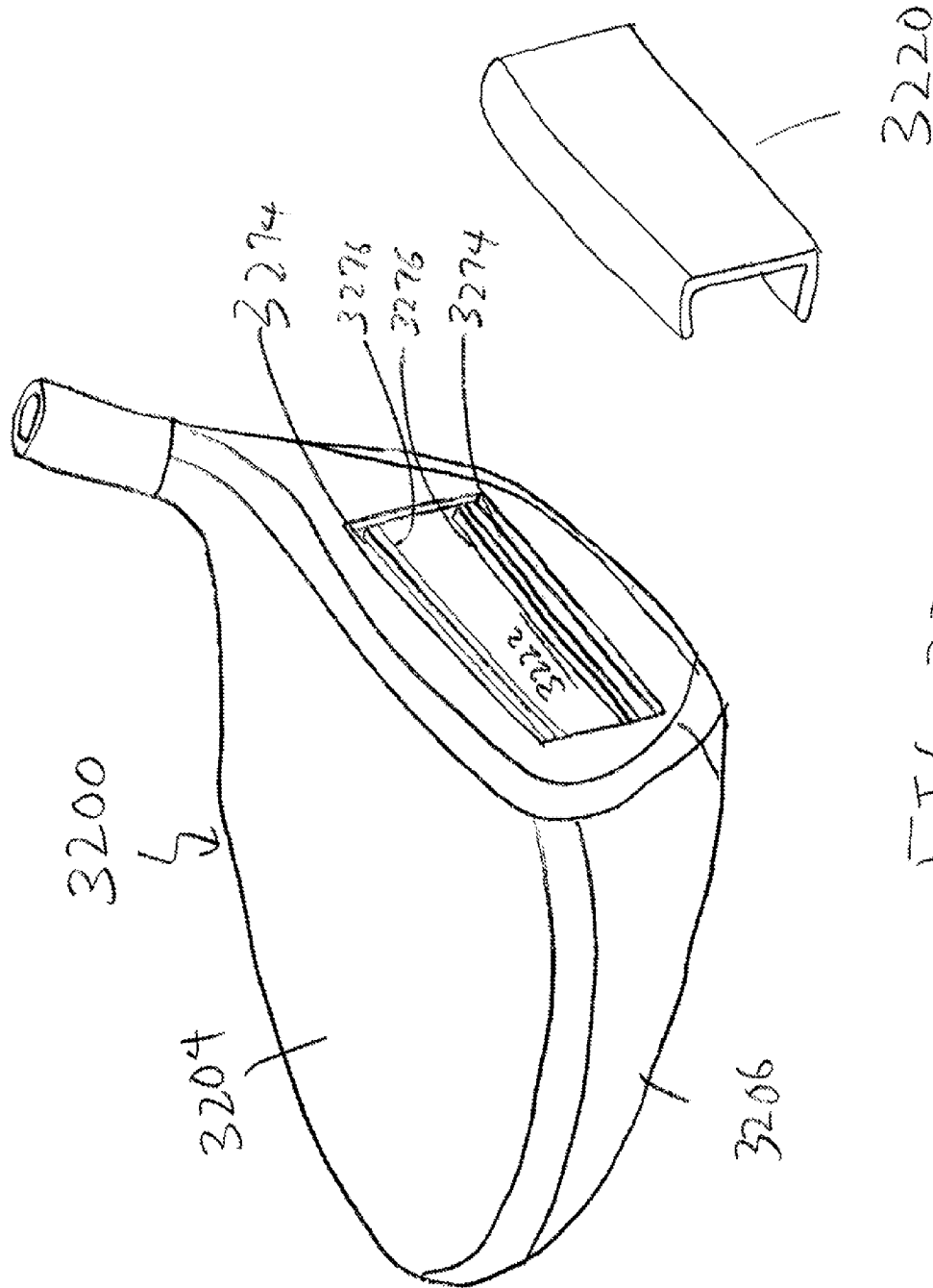

FIG. 32

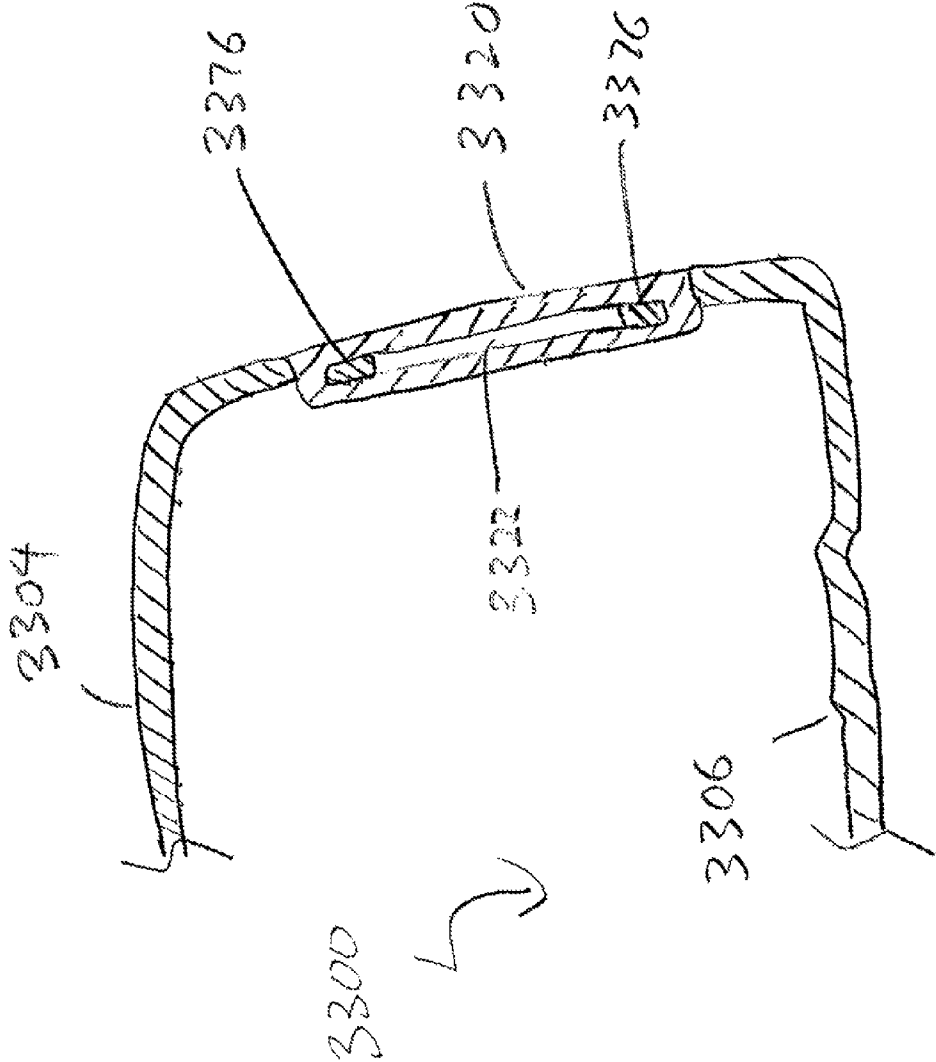

FIG. 33



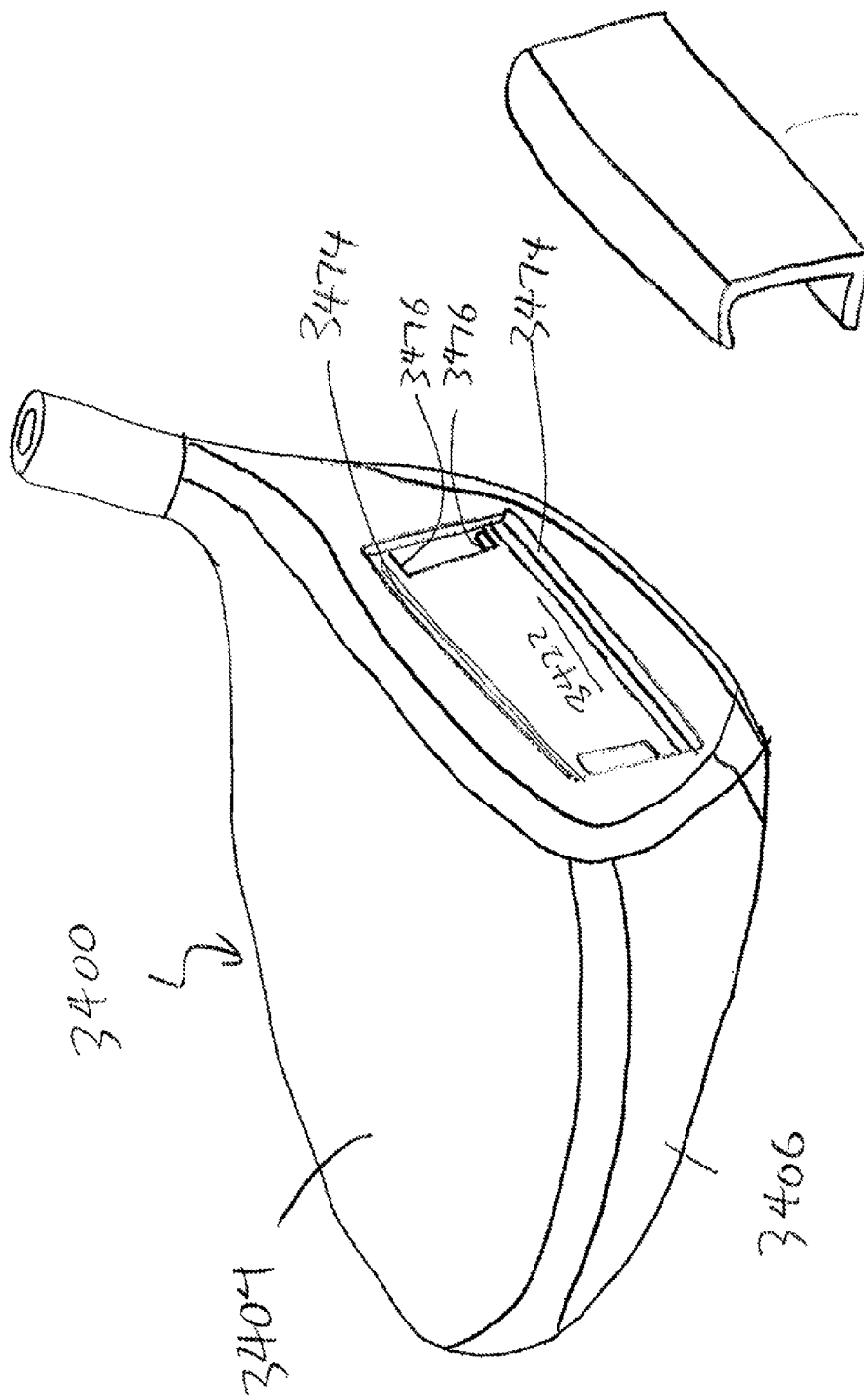

FIG. 34

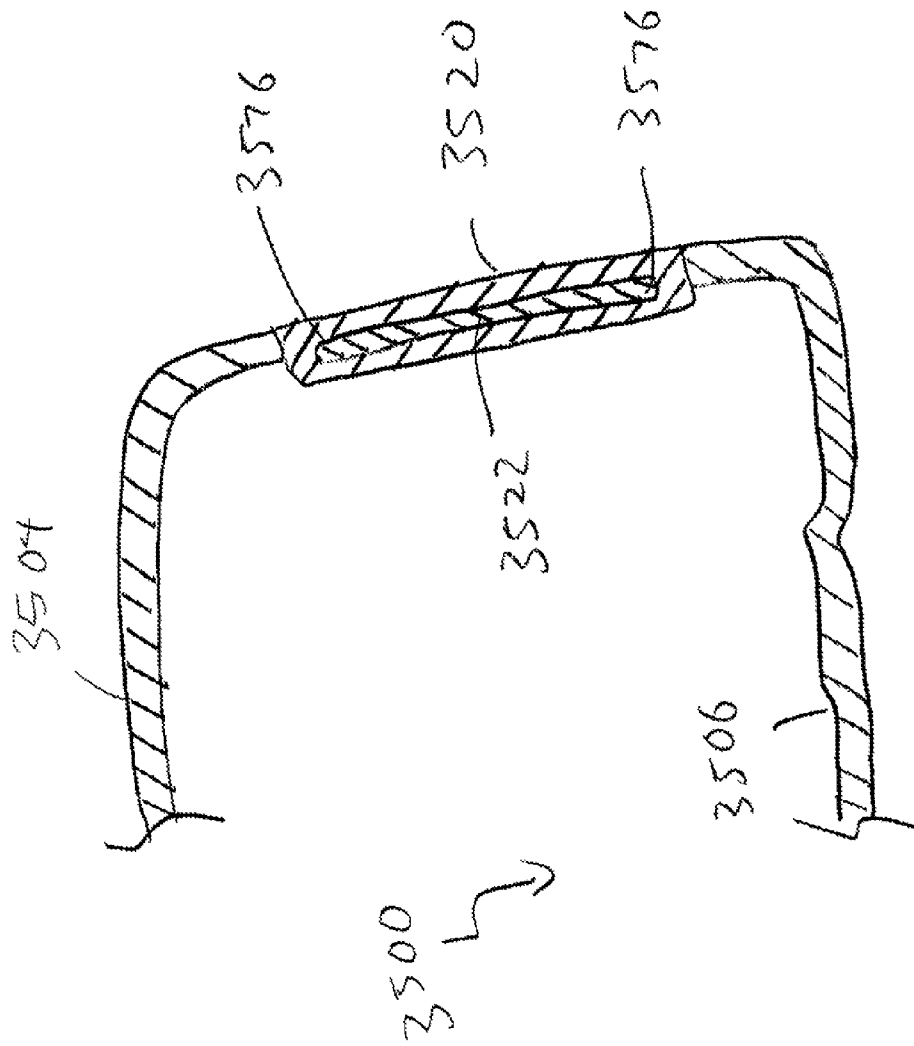

FIG. 35

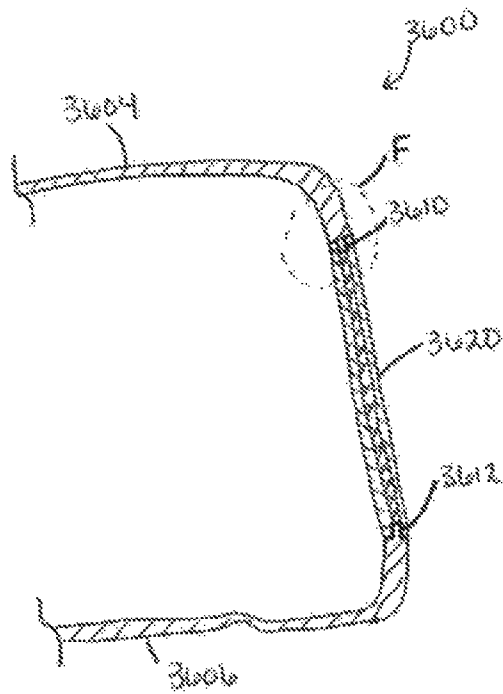

FIG. 36A

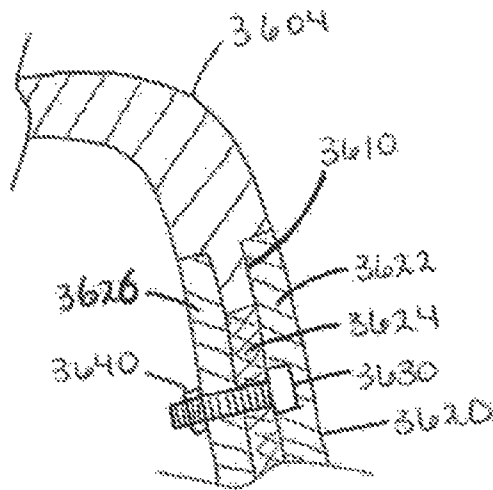

FIG. 36B

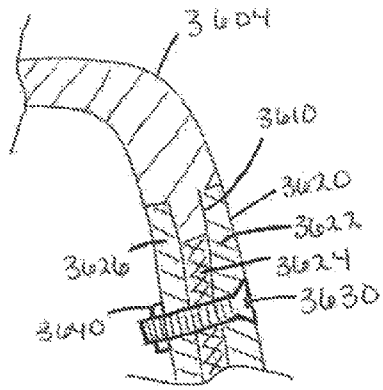

FIG. 36C

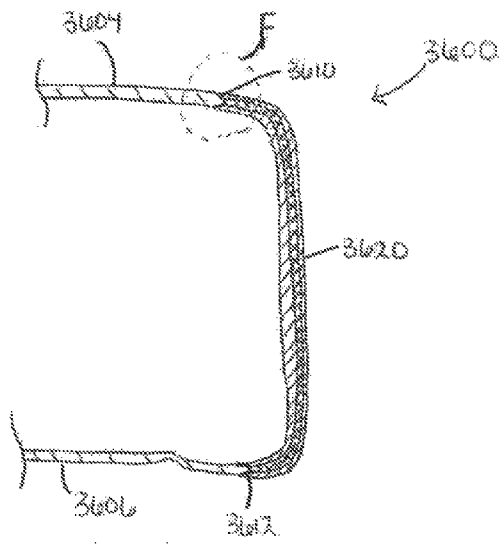

FIG. 36D

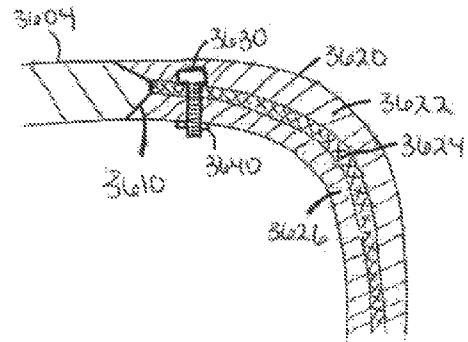

FIG. 36E

## GOLF CLUB HEAD HAVING A MULTI-MATERIAL FACE

### CROSS-REFERENCE TO RELATED APPLICATIONS

This application is a continuation-in-part of U.S. patent application Ser. No. 12/916,760, filed Nov. 1, 2010, now U.S. Pat. No. 8,517,859, which is a continuation-in-part of U.S. patent application Ser. No. 12/832,461, filed Jul. 8, 2010, now U.S. Pat. No. 8,221,261, the entire disclosures of which are hereby incorporated herein by reference.

### FIELD OF THE INVENTION

The present invention relates generally to a golf club head having a multi-material face, and to a method of attaching the multi-material face to the golf club head. More specifically, the present invention relates to a golf club head with a striking face having a pocket at the frontal portion of the striking face. The pocket at the frontal portion of the striking face may be filled with a material having a different density than the material used to form the remainder of the striking face. The multi-material striking face in accordance with the present invention may utilize a lighter second material having a second density to fill in the pocket created by the striking face, while the remainder of the striking face utilizes a heavier first material that has a first density. The golf club head created by this multi-material striking face may have a Characteristic Time (CT) slope of greater than about 5 and less than about 50 measured in accordance with the United States Golf Association's (USGA's) Characteristic Time (CT) test.

### BACKGROUND OF THE INVENTION

In order to improve the performance of a golf club, golf club designers have constantly struggled with finding different ways to hit a golf ball longer and straighter. Designing a golf club that hits a golf ball longer may generally require an improvement in the ability of the golf club head to effectively transfer the energy generated by the golfer onto a golf ball via the golf club. Hitting a golf ball straighter, on the other hand, will generally require an improvement in the ability of the golf club to keep the golf ball on a relatively straight path even if the golf ball is struck off-center; as a golf ball that is struck at the center of the golf club head will generally maintain a relatively straight flight path.

Effectively transferring the energy generated by the golfer onto a golf ball in order to hit a golf ball further may be largely related to the Coefficient of Restitution (COR) between the golf club and the golf ball. The COR between a golf club and a golf ball may generally relate to a fractional value representing the ratio of velocities of the objects before and after they impact each other. U.S. Pat. No. 7,281,994 to De Shiell et al. provides one good example that explains this COR concept by discussing how a golf club head utilizing a thinner striking face may deflect more when impacting a golf ball to result in a higher COR; which results in greater travel distance.

Being able to hit a golf ball relatively straight even when the club strikes a golf ball at a location that is offset from the center of the striking face may generally involve the ability of the golf club to resist rotational twisting; a phenomenon that occurs naturally during off-center hits. U.S. Pat. No. 5,058,895 to Igarashi goes into more detail on this concept by discussing the advantages of creating a golf club with a higher Moment of Inertia (MOI), which is a way to quantify the

ability of a golf club to resist rotational twisting when it strikes a golf ball at a location that is offset from the geometric center of the golf club head. More specifically, U.S. Pat. No. 5,058,895 to Igarashi utilizes weights at the rear toe, rear center, and rear heel portion of the golf club head as one of the ways to increase the MOI of the golf club head, which in turn allows the golf club to hit a golf ball straighter. It should be noted that although the additional weights around the rear perimeter of the golf club head may increase the MOI of the golf club, these weights can not be added freely without concern for the overall weight of the golf club head. Because it may be undesirable to add to the overall weight of the golf club head, adding weight to the rear portion of the golf club head will generally require that same amount of weight to be eliminated from other areas of the golf club head.

Based on the two above examples, it can be seen that removing weight from the striking face of the golf club head not only allows the golf club head to have a thinner face with a higher COR, the weight removed can be placed at a more optimal location to increase the MOI of the golf club head. One of the earlier attempts to remove unnecessary weight from the striking face of a golf club can be seen in U.S. Pat. No. 5,163,682 to Schmidt et al. wherein the striking face of a golf club head has a variable thickness by making the part of the striking face that is not subjected to the direct impact thinner.

U.S. Pat. No. 5,425,538 to Vincent et al. shows an alternative way to remove unnecessary weight from the striking face of a golf club by utilizing a fiber-based composite material. Because fiber-based composite materials may generally have a density that is less than the density of traditional metals such as steel or titanium, the simple substitute of this fiber-based composite material alone will generate a significant amount of discretionary weight that can be used to improve the MOI of a golf club. Fiber-based composite materials, because of their relatively lightweight characteristics, tend to be desirable removing weight from various portions of the golf club head. However, because the durability of such a lightweight fiber-based composite material can be inferior compared to a metallic type material, completely replacing the striking face of a golf club with the lightweight fiber-based composite material could sacrifice the durability of the golf club head.

U.S. Pat. No. 7,628,712 to Chao et al. discloses one way to improve the durability of striking face made out of a fiber-based composite material by using a metallic cap to encompass the fiber-based composite material used to construct the striking plate of the golf club head. The metallic cap aids in resisting wear of the striking face that results from repeated impacts with a golf ball, while the rim around the side edges of the metallic ring further protects the composite from peeling and delaminating. The utilization of a metallic cap, although helps improve the durability of the striking face of the golf club head, may not be a viable solution, as severe impact could dislodge the fiber-based composite from the cap.

In addition to the durability concerns of the fiber resin matrix itself, utilizing composite materials to form the striking face of a golf club offers additional challenges. More specifically, one of the major design hurdles arises when a designer attempts to bond a fiber-based composite material to a metallic material, especially at a location that is subjected to high stress levels normally generated when a golf club hits a golf ball. Finally, the usage of composite type materials to form the striking face portion of the golf club head may also be undesirable because it alters the sound and feel of a golf club away from what a golfer are accustomed to, deterring a golfer from such a product.

Ultimately, despite all of the attempt to improve the performance of a golf club head by experimenting with alternative face materials, the prior art lacks a way to create a striking face that saves weight, improves COR, and is sufficiently durable without sacrificing the sound and feel of the golf club head. Hence, as it can be seen from above, there is a need in the field for a golf club head having a striking face that can save weight, improve the COR of the golf club head, and can endure the high stress levels created by the impact with a golf ball, all without sacrificing the sound and feel of the golf club head.

#### BRIEF SUMMARY OF THE INVENTION

One aspect of the present invention is a golf club head comprising a striking face and a body portion. The striking face is located near a forward portion of the golf club head while the body portion is connected to an aft portion of the striking face. The striking face further comprising a perimeter portion made out of a first material having a first density around a border of the striking face and a central portion near a center of the striking face surrounded by the perimeter portion; wherein the central portion defines a pocket in the center of the striking face. The body portion further comprises a crown, a sole, and a skirt. The pocket formed at the central portion of the striking face is filled with a face insert that is made out of a second material having a second density; wherein the second density is less than the first density. Finally, the striking face disclosed above has a characteristic time slope of greater than about 5 and less than about 50.

In another aspect of the present invention, a golf club head is provided comprising a body made out of a first material having a first density having a front portion defining a pocket therein, and a face insert made out of a second material having a second density disposed within said pocket; wherein the second density is less than the first density. The striking face has a characteristic time slope of greater than about 5 and less than about 50, and the golf club head has a first peak frequency to volume ratio of greater than about 7.0 hertz/cc, the first peak frequency to volume ratio is defined as a first peak frequency of a signal power diagram of the sound of the golf club head as it impacts a golf ball divided by a volume of the golf club head.

In another aspect of the present invention, a golf club head is provided comprising a striking face made out of a first material having a first density located near a forward portion of the golf club head, said striking face defining a pocket at a center of the striking face, and a face insert made out of a second material having a second density positioned within the pocket; wherein the second density is less than the first density. The striking face disclosed here also comprises an undercut around a perimeter of the pocket.

In yet another aspect of the present invention, a golf club head is provided comprising a face and a body portion. The face comprises an outer layer including a plurality of male fasteners projecting from an inner surface thereof; a lightweight layer penetrated by the male fasteners; and a plurality of female fasteners, each of which is affixed to one of the male fasteners.

These and other features, aspects and advantages of the present invention will become better understood with reference to the following drawings, description and claims.

#### BRIEF DESCRIPTION OF THE DRAWINGS

The foregoing and other features and advantages of the invention will be apparent from the following description of

the invention as illustrated in the accompanying drawings. The accompanying drawings, which are incorporated herein and form a part of the specification, further serve to explain the principles of the invention and to enable a person skilled in the pertinent art to make and use the invention.

FIG. 1 shows a perspective view of a golf club head in accordance with an exemplary embodiment of the present invention;

FIG. 2 shows an exploded perspective view of a golf club head with the face insert detached from its pocket within the golf club head in accordance with an exemplary embodiment of the present invention;

FIG. 3 shows a frontal view of the golf club head in accordance with an exemplary embodiment of the present invention;

FIG. 4 shows a cross-sectional view of the golf club head taken along cross-sectional line A-A' shown in FIG. 3 in accordance with an exemplary embodiment of the present invention;

FIG. 5 shows an enlarged cross-sectional view of the golf club head focusing on the striking face portion of the golf club head in accordance with one exemplary embodiment of the present invention;

FIG. 6 shows an enlarged cross-sectional view of the golf club head focusing on the striking face portion of the golf club head in accordance with a further exemplary embodiment of the present invention;

FIG. 6A shows a further enlarged cross-sectional view of the golf club head focusing on the perimeter of the pocket in accordance with a further exemplary embodiment of the present invention;

FIG. 6B shows a further enlarged cross-sectional view of the golf club head focusing on the perimeter of the pocket in accordance with a further exemplary embodiment of the present invention;

FIG. 6C shows a further enlarged cross-sectional view of the golf club head focusing on the perimeter of the pocket in accordance with a further exemplary embodiment of the present invention;

FIG. 6D shows a further enlarged cross-sectional view of the golf club head focusing on the perimeter of the pocket in accordance with a further exemplary embodiment of the present invention;

FIG. 7 shows a signal power diagram of a prior art golf club head quantifying the sound of the prior art golf club head;

FIG. 8 shows a signal power diagram of a different prior art golf club head quantifying the sound of the different prior art golf club head;

FIG. 9 shows a signal power diagram of an exemplary embodiment of the present invention that quantifies the sound of the current exemplary golf club head;

FIG. 10 shows characteristic time plots of the various data collected from an exemplary inventive golf club head in accordance with the USGA CT test;

FIG. 11 shows an enlarged cross-sectional view of the golf club head focusing on the striking face portion of the golf club head in accordance with a further alternative exemplary embodiment of the present invention;

FIG. 12 shows an enlarged cross-sectional view of the golf club head focusing on the striking face portion of the golf club head in accordance with a further alternative exemplary embodiment of the present invention;

FIG. 13 shows an enlarged cross-sectional view of the golf club head focusing on the striking face portion of the golf club head in accordance with a further alternative exemplary embodiment of the present invention;

5

FIG. 14 shows an enlarged cross-sectional view of the golf club head focusing on the striking face portion of the golf club head in accordance with a further alternative exemplary embodiment of the present invention;

FIG. 15 shows an enlarged cross-sectional view of the golf club head focusing on the striking face portion of the golf club head in accordance with a further alternative exemplary embodiment of the present invention;

FIG. 16 shows an enlarged cross-sectional view of the golf club head focusing on the striking face portion of the golf club head in accordance with a further alternative exemplary embodiment of the present invention;

FIG. 17 shows an enlarged cross-sectional view of the golf club head focusing on the striking face portion of the golf club head in accordance with a further alternative exemplary embodiment of the present invention;

FIG. 18 shows an enlarged cross-sectional view of the golf club head focusing on the striking face portion of the golf club head in accordance with a further alternative exemplary embodiment of the present invention;

FIG. 19 shows an enlarged cross-sectional view of the golf club head focusing on the striking face portion of the golf club head in accordance with a further alternative exemplary embodiment of the present invention;

FIG. 20 shows a stress and strain diagram of the fiber within the composite material used to make the face insert in accordance with an exemplary embodiment of the present invention;

FIG. 21 shows an exploded perspective view of a particular type of fiber orientation used to construct the face insert in accordance with an exemplary embodiment of the present invention;

FIG. 22 shows an exploded perspective view of a different type of fiber orientation used to construct the face insert in accordance with a different exemplary embodiment of the present invention;

FIG. 23 shows an exploded perspective view of a different type of fiber orientation used to construct the face insert in accordance with a different exemplary embodiment of the present invention;

FIG. 24 shows an exploded perspective view of a golf club head in accordance with an alternative embodiment of the present invention;

FIG. 25 shows a cross-sectional view of a golf club head in accordance with an alternative embodiment of the present invention;

FIG. 26 shows a cross-sectional view of a golf club head in accordance with an alternative embodiment of the present invention;

FIG. 27 shows a cross-sectional view of a golf club head in accordance with an alternative embodiment of the present invention;

FIG. 28 shows a an exploded perspective view of a golf club head in accordance with an alternative embodiment of the present invention;

FIG. 29 shows a cross-sectional view of a golf club head in accordance with an alternative embodiment of the present invention;

FIG. 30 shows a cross-se a cross-sectional view of a golf club head in accordance with an alternative embodiment of the present invention;

FIG. 31 shows a cross-sectional view of a golf club head in accordance with an alternative embodiment of the present invention;

FIG. 32 shows an exploded perspective view of a golf club head in accordance with an alternative embodiment of the present invention;

6

FIG. 33 shows a cross-sectional view of a golf club head in accordance with an alternative embodiment of the present invention;

FIG. 34 shows an exploded perspective view of a golf club head in accordance with an alternative embodiment of the present invention;

FIG. 35 shows a cross-sectional view of a golf club head in accordance with an alternative embodiment of the present invention;

FIG. 36A shows a cross-sectional view of a golf club head in accordance with an alternative embodiment of the present invention;

FIG. 36B shows a cross-sectional view of detail F, shown in FIG. 36A, in accordance with an alternative embodiment of the present invention;

FIG. 36C shows a cross-sectional view of detail F, shown in FIG. 36A, in accordance with an alternative embodiment of the present invention;

FIG. 36D shows a cross-sectional view of a golf club head in accordance with an alternative embodiment of the present invention; and

FIG. 36E shows a cross-sectional view of detail F, shown in FIG. 36D, in accordance with an alternative embodiment of the present invention.

#### DETAILED DESCRIPTION OF THE INVENTION

The following detailed description describes the best currently contemplated modes of carrying out the invention. The description is not to be taken in a limiting sense, but is made merely for the purpose of illustrating the general principles of the invention, since the scope of the invention is best defined by the appended claims.

Various inventive features are described below and each can be used independently of one another or in combination with other features. However, any single inventive feature may not address any or all of the problems discussed above or may only address one of the problems discussed above. Further, one or more of the problems discussed above may not be fully addressed by any of the features described below.

FIG. 1 of the accompanying drawings shows a perspective view of a golf club head **100** in accordance with an exemplary embodiment of the present invention. More specifically, FIG. 1 shows a golf club head **100** with a striking face **102** located at a forward portion of the golf club head **100** with a body portion connected to an aft portion of the striking face **102**. The aft body portion of the golf club head **100**, in this current exemplary embodiment, may generally be comprised of a crown **104**, a sole **106**, and a skirt **108**. The striking face **102** described in this current exemplary embodiment of the present invention may generally have a perimeter portion **110** around the external border of the striking face **102** and a central portion **112** at the central region of the striking face **102**. This distinction between the perimeter portion **110** and the central portion **112** of the striking face **102** is important in this current exemplary embodiment of the present invention because a different material could be used to construct the central portion **112** of the striking face **102** than what is used to for the remainder of the golf club head **100**, including the perimeter portion **110**. Despite the above, perimeter portion **110** could also be constructed out of a different material than the remainder of the golf club head **100** as well as the striking face **102** to further improve the performance of the golf club head **100** without departing from the scope and content of the present invention.

In one exemplary embodiment of the present invention the perimeter portion **110** of the striking face **102** may generally

be constructed out of a first material that may generally be metallic with a relatively high first density; for example, titanium or steel. These materials, although typically strong enough to withstand the impact forces between a golf club head **100** and a golf ball, tend to be on the heavy side. More specifically, steel, being the heavier of the two materials mentioned above, may generally have a density of between about 5.0 g/cm<sup>3</sup> and 8.00 g/cm<sup>3</sup>. Titanium, on the other hand, may generally be less dense than steel, with a density of about 4.00 g/cm<sup>3</sup> to about 5.00 g/cm<sup>3</sup>.

With discretionary weight within a golf club at such a premium, any amount of weight that can be saved from any portion of the golf club head **100** can be helpful in improving the Center of Gravity (CG) location and the Moment Of Inertia (MOI) of the golf club head **100**. Hence, in an attempt to save weight from the striking face **102** of the golf club head **100**, the current exemplary embodiment of the present invention shown in FIG. **1** may utilize a second material with a relatively low second density to construct the central portion **112** of the striking face **102**. More specifically, the central portion **112** of the striking face **102** may be constructed using an aluminum material with a density of about 2.7 g/cm<sup>3</sup>, a magnesium material with a density of about 1.738 g/cm<sup>3</sup>, a composite type material with a density of about 1.70 g/cm<sup>3</sup>, or any other material having a lower density than the density of the first material all without departing from the present invention. Due to the lighter second density of the second material used to construct the central portion **112**, the total weight of the entire striking face **112** may be significantly less and in the range of about 15 to about 25 grams; especially when compared to a striking face **102** that is constructed completely out of a denser material such as titanium. This weight savings may generally be calculated based on a striking face **112** that is about 60 mm to 80 mm wide, about 25 mm to 50 mm high, and about 2.0 mm to 3.5 mm thick. It is worth noting that utilizing a second material with a lower second density to construct the central portion **112** of the striking face **102** may come with certain design challenges, as materials having a lower density may not be sufficiently strong enough to withstand the impact forces between a golf club head **100** and a golf ball.

The current invention, in order to address the durability issue above, may utilize a dual layered central portion **112** comprised out of two different materials that could offer up a combination of both the lightweight benefits of the second material in conjunction with the strength and durability benefits of the first material. FIG. **2** of the accompanying drawings showing an exploded perspective view of a golf club head **200** gives a better illustration of the dual layered central portion **212** in accordance with an exemplary embodiment of the present invention. More specifically, the exploded view of golf club head **200** allows the face insert **220** and the pocket **222** to be shown. Because the pocket **222** shown in the current exemplary embodiment of the present invention is not designed to completely penetrate the entire thickness of the central portion of the striking face **210**, it leaves a layer of metallic first material to serve as a backing to the lightweight second material used for the face insert **220**. The face insert **220**, as discussed above being made out of a lightweight second material, may generally be constructed independently from the remainder of the golf club head **200**, and inserted into its resting place within the pocket **222** after the golf club head is completed. Finally, it is worth noting that the geometry of the face insert **220** may generally mimic the geometry of the pocket **222**, allowing the two components to be seamlessly assembled with one another.

Face insert **220**, although discussed above as being capable of being comprised out of numerous types of light density materials, may generally be comprised out of composite type material in one exemplary embodiment of the present invention. Composite type materials, as referred to in this current invention, may generally apply to engineered materials made from two or more constituent materials with significantly different physical or chemical properties which remain separate and distinct on a macroscopic level. More specifically, composite type material may refer to woven webs of carbon fiber that is impregnated with a thermoplastic or thermohardenable resin material; more commonly known as resin impregnated carbon fiber.

FIG. **3** of the accompanying drawings shows a frontal view of a golf club head **300** in accordance with an exemplary embodiment of the present invention. The frontal view of the golf club head **300** shows the relative size, distance, and percentage of the central portion **312** compared to the perimeter portion **310** as well as the striking face **302**. More specifically, in this exemplary embodiment of the present invention, the striking face **302** may generally have a frontal surface area of greater than about 3600 mm<sup>2</sup> and less than about 4000 mm<sup>2</sup>, more preferably greater than about 3300 mm<sup>2</sup> and less than about 3900 mm<sup>2</sup>, and most preferably about 3800 mm<sup>2</sup>. The central portion **312**, on the other hand, may generally have a frontal surface area of greater than about 2500 mm<sup>2</sup> and less than about 2900 mm<sup>2</sup>, more preferably greater than about 2600 mm<sup>2</sup> and less than about 2800 mm<sup>2</sup>, and most preferably about 2700 mm<sup>2</sup>. Finally, the frontal surface area of the perimeter portion **310** may generally be able derived by subtracting the area of the central portion **312** from the striking face **302**, yielding a range of greater than about 900 mm<sup>2</sup> and less than about 1300 mm<sup>2</sup>, more preferably greater than about 1000 mm<sup>2</sup> and less than about 1200 mm<sup>2</sup>, and most preferably about 1100 mm<sup>2</sup>. It should be noted that the central portion **312** shown in the current exemplary embodiment may mimic the external geometry of the striking face **302** in order to improve the coverage of the central region without departing from the scope and content of the present invention.

In order to have a sufficiently large pocket at the central portion **312** that is comprised out of a lightweight second material, the central portion **312** must make up a significant portion of the striking face **302**. Alternatively speaking, the central portion to striking face ratio needs to be greater than about 0.65, more preferably greater than about 0.70, and most preferably greater than about 0.75. The central portion to striking face ratio is defined as the frontal surface area of the central portion **312** divided by the frontal surface area of the striking face **302** as shown below in Equation (1):

$$\text{Central Portion to Striking Face Ratio} = \frac{\text{Frontal Surface Area of Central Portion}}{\text{Frontal Surface Area of Striking Face}} \quad \text{Eq. (1)}$$

Ultimately, the striking face **302** could be divided into a central portion **312** and a perimeter portion **313**, wherein the central portion **312** defines a pocket that can be filled with the secondary material mentioned above.

The frontal view of the golf club head **300** shown in FIG. **3** also shows the offset of the central portion **312** away from the perimeter of the striking face **302** being at an offset distance  $d_1$ , defined as the distance between the perimeter of the



striking face 302 and the perimeter of the central portion 312. Offset distance d1, as shown in this current exemplary embodiment, may generally help define the size of the pocket within the central portion 312, which determines the amount of second material that can be used to fill in the pocket to alter the performance of the golf club head 300. In one exemplary embodiment of the present invention, offset distance d1 may generally be less than about 0.5 inches, more preferably less than about 0.33 inches, and most preferably greater than about 0.25 inches all without departing from the scope and content of the present invention. Although the golf club head 300 shown in FIG. 3 shows a constant offset distance d1 across the entire perimeter of the striking face 302, the offset distance d1 may vary to find the correct balance between weight removal and durability without departing from the scope and content of the present invention.

FIG. 4 of the accompanying drawings shows a cross-sectional view of a golf club head 400 in accordance with an exemplary embodiment of the present invention taken along cross-sectional line A-A' shown in FIG. 3. The cross-sectional view of the golf club head 400 allows a clearer view of the pocket 422 as well as the backing portion 423 of the central portion 412 of the golf club head 400. Because the weight savings achievable by the lightweight second material within the pocket 422 needs to be balanced out with the strength and durability of the metallic material within the backing portion 423, the relative thicknesses of the pocket 422 and the backing portion 423 are important to the current invention. In one exemplary embodiment of the present invention, the depth d2 of the pocket may be kept constant at greater than about 0.2 mm and less than about 2.0 mm, more preferably at greater than about 0.5 mm and less than about 1.5 mm, and most preferably at about 1.0 mm. In order to balance out the durability sacrificed by the utilization of a lighter second material within the pocket 422, the backing portion 423 may generally need to maintain a thickness d3 that allows the golf club head 400 to endure the impact forces with a golf ball. Hence, the thickness d3 of the backing portion 423 may generally have a constant thickness that is greater than about 1.5 mm and less than about 3.0 mm, more preferably greater than about 1.75 mm and less than about 2.75 mm, most preferably about 2.25 mm.

Despite the thicknesses articulated above, it should be noted that the more important number here is the ratio of the relative thickness between the d2 and d3; which quantifies the relative thicknesses of depth d2 of the pocket 422 as well as the thickness d3 of the backing portion 423. This ratio, referred to as a "striking thickness ratio" within the context of this application, indirectly quantifies the ability of the golf club head 400 to reduce unnecessary weight from the striking face 402 while maintaining the durability of the striking face 402. Striking thickness ratio, as referred to in this current application, may more specifically be defined as the depth d2 of the pocket 422 divided by the thicknesses d3 of the backing portion 423 shown below in Equation (2):

$$\text{Striking Thickness Ratio} = \frac{\text{depth (d2) of pocket}}{\text{thickness (d3) of backing portion}} \quad \text{Eq. (2)}$$

The striking thickness ratio, as described above in this exemplary embodiment, may generally be less than about 1.0, more preferably less than about 0.8, and most preferably less than about 0.7.

FIG. 5 of the accompanying drawings shows an enlarged cross-sectional view of the circular region B shown in FIG. 4. More specifically, the enlarged view of the striking face 402 of the golf club head 400 shown in FIG. 5 allows a clearer view of relative thicknesses d3 and depth d2 of the backing portion 423 and the pocket 422 respectively. In addition to the above, FIG. 5 also shows the face insert 520 being constructed out of a second material having a second density being removed from its resting place within the pocket 522. One of the first things to recognize about FIG. 5 is the relative size and shape of the face insert 520 being reasonably similar to the size and shape of the pocket 522. Put it in another way, the face insert 520 may generally be designed with a size and shape that allows it to fit within the pocket 522 without departing from the scope and content of the present invention. More specifically, as it can be seen from FIG. 5, the thickness d2 of the face insert may generally be substantially similar to the depth d2 of the pocket 522, illustrating the similarities.

Although minimally visible from FIG. 5, it is commonly known that the striking face 502 portion of a modern day golf club head may generally have a slight curvature to help correct the adverse effects resulting from off center hits. This slight curvature of the striking face 502 portion of the modern day golf club head may be more commonly known as the bulge and roll of the golf club head, depending on whether the point of reference is taken from the horizontal orientation or a vertical orientation. It is worth noting here that the thicknesses d2 of the striking face 502 and/or the pocket 522 may generally be determined from the frontal surface of the striking face 502, meaning the pocket 522 will have the same bulge and roll curvature as the front of the striking face 520. Maintaining the bulge and roll curvature radius within the pocket 522 is advantageous to the durability of the striking face 502 of the golf club head, as a convex shaped surface will be able to absorb impact forces better than a flat or even concave shaped pocket 522. It should be noted, however, the pocket 522 need not have a convex surface in all embodiments to be within the scope and content of the present invention, the internal surface of the pocket 522 may be flat or even have a concaved shape, especially in situations where the striking face 502 is already durable enough to absorb the impact forces.

The relative similar size and shape of the face insert 520 and the pocket 522 will generally help enhance the bonding of the face insert 520 within the pocket 522. However, in addition to this pre-existing mechanical bond utilizing the geometry of the components, the bond between the face insert 520 and the pocket 522 could generally be enhanced with the usage of an adhesive type substance. Adhesive type substance, as discussed in this current application, may generally be a synthetic type adhesive; however, adhesive type substance may also be a natural adhesive, a contact adhesive, a trying adhesive, a hot melt adhesive, UV light curing adhesive, pressure sensitive adhesive, or any type of adhesive capable of creating a chemical bond that holds the face insert 520 within the pocket 522 all without departing from the scope and content of the present invention.

FIGS. 6, 6A, 6B, 6C, and 6D of the accompanying drawings shows further alternative embodiments of the present invention wherein the pocket 622 may contain an undercut 628 around the perimeter engagement portion C between the face insert 620 within the pocket 622 that further enhances the bond between the two above mentioned components. More specifically, FIGS. 6A, 6B, 6C, and 6D show enlarged views of various different types of undercut 628 that could be used to enhance the attachment of the face insert 620 within the pocket 622 all without departing from the scope and content

of the present invention. Before going into more detail about the various pockets **622** geometries, a brief discussion regarding the method of inserting the face insert **620** into the pocket **622** having such an undercut **628** will help explain the ingenuity of the current invention. Looking at FIGS. **6**, **6A**, **6B**, **6C**, and **6D**, it can be seen that it could be physically difficult to place the face insert **620** having a larger diameter past the undercut **628** into the pocket **622**. Hence, in order to place the face insert **620** into a pocket **622** that has an undercut **628**, the composite material used to form the face insert **620** may need to be placed in the pocket **622** before curing. Resin impregnated materials, unlike metallic materials that have a rigid body, may generally have a pliable structure until the resin is cured. Hence, it can be seen from above, if a composite type material is used to construct the face insert **620**, the pliable nature of the composite material before curing allows the face insert to fit into the pocket **622**.

In addition to the pliable nature of the resin impregnated composite type material used to construct the face insert **620**, the multiple layers of fibrous material used to form the resin impregnated composite will also allow the pocket **622** to be filled with the resin impregnated composite around the undercut **628**. More specifically, because resin impregnated composite material is built by layering thin layers of resin fibers on top of one another, the various fibers layers can be filled into the pocket **622** to get around the undercut **628** without departing from the scope and content of the present invention.

FIGS. **6A**, **6B**, **6C**, and **6D** all show different enlarged views of the perimeter engagement portion **C** allowing a clearer view of the various undercut **628** geometries in accordance with various embodiments of the present invention. More specifically, FIG. **6A** shows a V shaped undercut **628** that helps secure the face insert **620** in the pocket **622**. FIG. **6B** shows a V shaped undercut **628** with a flat portion near the external tip of the undercut **628** to eliminate sharp corners that could result in impact high stress. FIG. **6C** shows a further alternative embodiment of the present invention wherein a U shaped undercut **628** may be used to help secure the face insert **620** in the pocket **622**. Finally, FIG. **6D** shows a further alternative embodiment of the present invention wherein a U shaped undercut **628** has a flat tip to completely eliminate sharp corners that could crack or break during impact.

At this point, it is worthwhile to recognize that having a pocket **622** at the striking face **602** portion of the golf club head may offer additional performance benefits than what's immediately recognizable. More specifically, in addition to the obvious performance benefits that can be achieved by creating more discretionary weight from this type of geometry shown above, utilizing this type of a pocket **622** will allow the golf club head to maintain the a desirable acoustic sound. Acoustic sound of a golf club head, although difficult to quantify, is something that greatly influences the perceived performance of a golf club head. Because composite type materials may generally offer a very different acoustic sound than a metallic type material, it may be important to the current invention to adjust the acoustic sound of the golf club head to be relatively similar to a golf club head having a completely metallic striking face.

FIG. **7** of the accompanying drawings shows a signal power diagram of a prior art golf club head having a completely metallic striking face, illustrating the acoustic characteristics of a golf club head that produces a desirable sound. More specifically, FIG. **7** captures the power **752** of the sound generated by the prior art golf club head as it impacts a golf ball as a function of the frequency **754**. This power **752** and frequency **754** may quantify the vibration of the various components of the golf club head such as the crown, sole, face, or

any other complement of a golf club head as it impacts a golf ball. As we can see from FIG. **7**, this prior art golf club head having a completely metallic striking face may produce a first peak **756** in sound power **752** at about 4,000 hertz. The peak **756** sound power **752**, as shown in this current prior art golf club head that has a completely metallic striking face, may generally have a total sound power output of about 0.2 watts. Hence, based on the above, it can be observed that a desirable sound of a golf club head with a completely metallic striking face may have a first peak of power at a frequency that is greater than about 3,500 hertz, more preferably greater than about 3,750 Hertz, and most preferably greater than about 4,000 Hertz.

FIG. **8** of the accompanying drawings shows a signal power diagram of a prior art golf club head having a completely composite striking face, illustrating the dramatic change in the acoustic sound characteristic of such a type of golf club head. Right off the bat, one can see from FIG. **8** the power of the sound produced by a prior art golf club head having a completely composite striking face is significantly less than that of a traditional prior golf club head that has a metallic striking face. Although barely noticeable when plotted in the same scale as the diagram in FIG. **7**, this completely composite prior art golf club head may generally have a first peak **856** in sound power **852** at about 3,000 hertz. The peak **856** sound power **852**, as shown in this current prior art golf club head having a completely composite striking face, may generally have a total sound power **852** output of less than about 0.002 watts. Hence, when compared to the signal power diagram of a prior art golf club head having a completely metallic striking face shown in FIG. **7**, one can see that completely replacing the striking face of a golf club head with composite material greatly sacrifices the desirable sound of a golf club head.

Turning now to FIG. **9** of the accompanying drawings we can see the signal power diagram of a golf club head in accordance with the current invention. Even at an initial glance, it is immediately noticeable that the signal power diagram of the current invention more resembles the signal power diagram of a prior art golf club head with a completely metallic striking face shown in FIG. **7**. More specifically, the signal power diagram of the current inventive golf club head may have a first peak **956** in sound power **952** occurring at greater than about 3,500 hertz and less than about 4,500 hertz, more preferably greater than about 3,750 hertz and less than about 4,250 hertz, and most preferably about 4,000 hertz. The peak **956** sound power **952** of the current inventive golf club head having a pocket at the striking face may yield a total sound power **952** output of greater than about 0.1 watts, more preferably greater than about 0.125 watts, most preferably about 0.15 watts. Because the signal power diagram of the current inventive golf club head shows significant similarities to the signal power diagram of a prior art golf club head with a completely metallic face, the acoustic sound of the current inventive golf club head is desirable despite having a composite type face insert.

Because the desirability of the acoustic sound coming from the different golf club heads are dependent upon the above mentioned values within the signal power diagram, it may be easier to quantify these values as a relationship to one another for ease of comparison. Equation (3) below creates a peak power to frequency ratio that captures the desirable sound of a golf club head in a way that is easily quantifiable.

$$\text{Peak Power to Frequency Ratio} = \frac{\text{Peak Power}}{\text{Frequency where Peak Power Occurs}} \quad \text{Eq. (3)}$$

The peak power to frequency ratio of a golf club head in accordance with an exemplary embodiment of the present invention may generally be greater than about  $2.5 \times 10^{-5}$  watts/hertz and less than about  $5 \times 10^{-5}$  watts/hertz, more preferably greater than about  $3.0 \times 10^{-5}$  watts/hertz and less than about  $4.5 \times 10^{-5}$  watts/hertz, and most preferably about  $4.0 \times 10^{-5}$  watts/hertz.

Although the peak power to frequency ratio described above quantifies the acoustic sound of a golf club as it impacts a golf ball, it does not take in consideration of the size of the golf club head. Because the acoustic sound of a golf club head may generally be caused by the vibration of the golf club head as it impacts a golf ball, the size of the golf club head is an important factor in determining the amount of surface area that is available for such a vibration when the golf club head is used to impact a golf ball. Hence, another important ratio to recognize in quantifying the sound of a golf club head may be the first peak frequency to volume ratio of a golf club head. Similar to the discussion above describing what the desirable sound it, the golf club head in accordance with the current invention may generally have a first peak in frequency occurring within the range of greater than about 3,500 hertz and less than about 4,500 hertz, more preferably greater than about 3,750 hertz and less than about 4,250 hertz, and most preferably about 4,000 hertz; as mentioned above. The golf club head in accordance with the current invention may generally have a total volume of greater than about 400 cubic centimeters (cc) and less than about 500 cc, more preferably greater than about 420 cc and less than 580 cc, and most preferably about 460 cc. Viewing the numbers above, the first peak frequency to volume ratio relationship may generally be greater than about 7.0 hertz/cc and less than about 15.0 hertz/cc, more preferably greater than about 9.0 hertz/cc and less than about 13.0 hertz/cc, most preferably about 8.0 hertz/cc. The first peak frequency to volume ratio is defined below as Equation (4).

$$\text{First Peak Frequency to Volume Ratio} = \frac{\text{First Peak Frequency}}{\text{Volume}} \quad \text{Eq. (4)}$$

In addition to the weight savings from the striking face of the golf club head and the improved acoustic performances described above, the utilization of a pocket that is filled with a second material having a second density yields an additional advantage in creating a golf club that can hit a golf ball further by increasing the Characteristic Time (CT) of the golf club head. CT, as currently known in the golfing industry, may generally relate to the amount of time a pendulum contacts the striking face of a golf club head after being dropped from various height that simulates different velocities. The velocity and time values, captured by an accelerometer attached to the pendulum, are then generally plotted against a function of the velocity. A linear trend line having a specific slope may be formed by the various data points, and the ultimate y-intercept may yield the CT value of the golf club head. More details regarding the exact apparatus and procedure used to acquire the CT value of a golf club head may be found in U.S. Pat. No. 6,837,094 to Pringle et al ('094 patent), the disclosure of which is incorporated by reference in its entirety.

FIG. 10 of the accompanying drawings shows a graphical representation of the various contact time results taken using the portable apparatus for measuring the flexibility of the striking face of a golf club head according to the steps described in the '094 patent. More specifically, FIG. 10 shows

the characteristic time results of the striking face of an exemplary golf club head in accordance with the current invention being plotted on the y-axis against the velocities of the pendulum at each of the respective data points **1062** being plotted on the x-axis. It should be noted that the velocities of the pendulum taken by an accelerometer attached to the pendulum is taken to an exponent value of  $-0.329$  in order to minimize the expected errors on the intercept value to create a linear relationship quantified by the Equation (5) below.

$$T = A + BV^{-k} \quad \text{Eq. (5)}$$

Wherein T equals the time for the velocity of the pendulum to rise from 5% to 95% of the maximum velocity recorded, B is the slope of the trend-line **1064** formed by the various data points **1062**, V is the velocity of the pendulum test at the various data points **1062**, and k is the exponential adjustment factor to minimize the error in the intercept value of the golf club head. The intercept between the trend-line **1064** and the y-axis, identified here as A, can be determined from the T, B, and V values above and may generally be the ultimate CT values used by the USGA which correlates to the ability of the golf club head to flex during impact with a golf ball.

It is worth noting here that, because the CT value here is determined based on the intercept A, the slope B of the trend-line **1064** formed by the various CT results of each individual data point **1062** from the pendulum test is an important factor that greatly affects the CT value. Because the current invention's utilizes a specific amount of composite that has a lowered second density within the pocket at the striking face portion of the golf club, the slope B of the trend-line **1064** created by the various data points may generally be steeper than the slope of a traditional prior art golf club head. More specifically, the slope formed from the trend-line **1064** of the various data points **1062** may be known here at the "characteristic time slope". The "characteristic time slope", as defined in the current invention above, may generally be greater than about 5 and less than about 50, more preferably greater than about 10 and less than about 45, even more preferably greater than about 12.5 and less than about 30, and most preferably greater than about 15 and less than about 20 as shown in FIG. 10. Although the units of the slope of the characteristic time slope trend-line **1064** is not specifically discussed above, it can may generally be derived by dividing the units for the time in microseconds by the value of the velocity to the  $-0.33$  power. The end results of the unit for the trend-line **1064** may generally be (microseconds/(seconds/meters)) or any other simplified form of that equation all without departing from the scope and content of the present invention. More information regarding the CT test, as defined and performed by the United States Golf Association (USGA), can be found in the Technical Description of the Pendulum Test, Revised Version, Discussion of Points Raised During Notice & Comment Period (November 2003), the disclosure of which is incorporated by reference in its entirety.

Returning to our previous discussion regarding the various geometries that can be used to create the pocket within the striking face portion of the golf club head we now turn to FIG. 11. FIG. 11 of the accompanying drawings shows a cross-sectional view of a golf club head having a pocket **1122** that may have a concave geometry. Although the concave geometry may decrease the thickness of the backing portion **1123**, the thinner back portion **1123** may offer additional deflection of the entire striking face **1102**, which could result in an increase in the performance of a golf club head. The thickness of the pocket **1122** may generally be shown in FIG. 11 as d3,

15

which could vary from about 0.2 mm to about 3.5 mm all without departing from the scope and content of the present invention.

FIG. 12 of the accompanying drawings shows a cross-sectional view of a golf club head having a pocket 1222 in accordance with a further alternative embodiment of the present invention. More specifically, the backing portion 1223 of this pocket 1222 may have a variable thickness, to promote a bigger sweet spot without affecting the geometry of the insert 1220 within the pocket 1222. More detailed discussion on the benefits of having a golf club head with a striking face that has a variable thickness may be found in U.S. Pat. No. 6,605,007 to Bissonnette et al, the disclosure of which is incorporated by reference in its entirety. The backing portion 1223 in accordance with this exemplary embodiment of the present invention may have two different thicknesses d5 and d6, with the thicker portion d6 located near the center of the striking face 1202. Despite the above, numerous other variations of this thickness profile with more distinct sections may be used all without departing from the scope and content of the present invention, so long as the backing portion has a variable thickness. Finally, it is worth noting that the thickness of the pocket 1222 and the thickness of the face insert 1220 may all be substantially unchanged at a constant thickness of d2 also without departing from the scope and content of the present invention.

FIG. 13 of the accompanying drawings shows a cross-sectional view of a golf club head having a further alternative geometry for the pocket 1322 and the face insert 1320 in accordance with a further alternative embodiment of the present invention. More specifically, the face insert 1320 in this exemplary embodiment of the present invention may have a variable thickness to improve the performance of the striking face 1320 of the golf club head. In order to accommodate this variable thickness on the face insert 1320, the backing portion 1323 may maintain a constant thickness to accommodate the variable thickness of the face insert 1320. In order to maintain the constant thickness of the backing portion 1323, this alternative embodiment of the present invention may generally yield a backing portion 1323 that has a bend near the central portion of the backing portion 1323 to match the thickened portion of the face insert 1320.

FIG. 14 of the accompanying drawings shows a cross-sectional view of a golf club head having a further alternative geometry for the pocket 1422 as well as the face insert 1420 in accordance with a further alternative embodiment of the present invention. More specifically, the face insert 1420 in this exemplary embodiment of the present invention may have a variable thickness to improve the performance of the striking face 1420 of the golf club head. The backing portion 1423, provides an alternative way to provide support to the face insert 1420 in providing a variable thickness that gets thinner at the central portion of the striking face 1402. This embodiment may be preferred to provide more flexural stiffness of the central portion as a thinner central portion may provide more deflection.

FIG. 15 of the accompanying drawings shows a cross-sectional view of a golf club head having a further alternative geometry for the pocket 1522 as well as the face insert 1520 in accordance with a further alternative embodiment of the present invention. More specifically, this embodiment of the present invention will have a backing portion 1523 that has an increased thickness at the central portion of the striking face 1502 to increase the durability of the golf club head. Hence, in order to accommodate the increased thickness of the backing portion 1523 at the central portion of the striking face 1502, the thickness of the face insert 1520 may generally

16

be thinner at central portion. This embodiment may be preferred in situation where the durability of the golf club head needs to be improved.

FIG. 16 of the accompanying drawings shows a cross-sectional view of a golf club head utilizing a different geometry to form the striking face 1602 in accordance with a further alternative embodiment of the present invention. More specifically, the backing portion 1623 forms a thinner but still complete striking face 1620, only to have it covered by the face insert 1620. This face insert 1620, although not conventional in size, serves the same purpose of removing unnecessary weight away from the striking face 1602 portion of the golf club head. This embodiment of the present invention provides advantages over prior art golf club heads in that it removes unnecessary weight away from the striking face 1602 of the golf club head while maintaining the structural integrity of the backing portion 1623 without departing from the scope and content of the present invention.

FIG. 17 of the accompanying drawings shows a cross-sectional view of a golf club head utilizing a slightly different geometry to form the striking face 1702 in accordance with a further alternative embodiment of the present invention. More specifically, this embodiment of the present invention will utilize two separate backing portions 1723 at opposite ends of the striking face 1702 leaving face insert 1720 unsupported at the central region. This alternative embodiment of the present invention may help completely eliminate the weight that's associated with a full backing portion 1723, further reducing the unnecessary weight associated with the striking face 1702 of the golf club head.

FIG. 18 of the accompanying drawings shows a cross-sectional view of a golf club head utilizing a different geometry to form the striking face 1802 in accordance with a further alternative embodiment of the present invention. This embodiment of the present invention shown in FIG. 18, in order to remove shift the bonding points away from the impact portion of the striking face 1802, has shifted the perimeter of the face insert 1820 towards the crown and sole portion of the golf club head. The shift of the bonding points away from the striking face 1802 is beneficial to the performance of the golf club head in that it moves the joints away from the points of the highest stress, decreasing the bonding strength required. As it can be seen from FIG. 18, the backing portion 1823 has been shifted towards the crown and sole portion of the golf club head to achieve this objective without departing from the scope and content of the present invention.

FIG. 19 of the accompanying drawings shows a cross-sectional view of a golf club head utilizing a different geometry to form the striking face 1902 in accordance with a further alternative embodiment of the present invention. More specifically, as it can be seen from FIG. 19, the face insert 1920 may wrap around the entire striking face 1902 of the golf club head to shift the joints away from the striking surface of the golf club head. However, the golf club head shown in FIG. 19 provides an additional performance advantage in that the metallic backing portion 1923 also wraps around to provide partial backing support for the face insert 1920. In addition to the above features, the face insert 1920 shown in this current exemplary embodiment of the present invention may utilize a thickened central portion to improve the size of the sweet spot without departing from the scope and content of the present invention.

It is worth noting here that the golf club heads shown FIGS. 17-19 are a little different from the earlier discussion of the various embodiments of the present invention in that the pockets created by the golf clubs shown in FIGS. 17-19 do not have a backing portion. In situations where the pocket is

supported by a metallic backing portion, the major cause of failure within the various plies of composite type material may be due to the delamination of the individual plies of composite fiber. However, in situations where the pocket is not supported by a backing portion, the major concern becomes the durability of the composite material itself, making the strength and durability of the composite type material a major concern. Despite the fact that almost any kind of resin impregnated carbon fiber may provide significant weight savings benefits, not all types of resin impregnated carbon fiber can meet the durability requirements needed to be used in a golf club head. In order to understand the different types of resin impregnated carbon fiber, it may be helpful to turn to FIG. 20 of the accompanying drawing showing a stress and strain chart 2000 of the fibers within the carbon fiber impregnated fiber that helps illustrate the relationship between the stress and the strain values of such a resin impregnated carbon fiber material that may be suitable for use as the second material in accordance with the present invention.

First and foremost, looking at the stress and strain chart 2000, we can see that the stress and strain relationship 2030 of the fibers of this composite type material may have linear elastic to failure characteristic. Linear elastic to failure characteristic in the fiber of a composite material may generally be more preferable than non-linear elastic to failure in that it allows for purely elastic deformation that does not alter the physical dimensions of the composite material. This type of purely linear elastic to failure characteristic in the fibers of the composite is more preferable than non-elastic elastic to failure because a brittle fiber that has a linear elastic to failure may generally yield a higher ultimate tensile strength than the yield stress achievable by a brittle fibers that exhibits non-linear elastic to failure characteristics. In addition to showing the linear elastic to failure characteristic of the fiber of the composite material, the stress and strain relationship 2030 of FIG. 20 also shows the strength and modulus of an ideal fiber for the composite material used for the current invention. More specifically, FIG. 20 shows that the fibers of the composite material used may generally have a tensile strength of greater than about 4.0 GPa and less than about 6.0 GPa, more preferably greater than about 4.5 GPa and less than about 5.5 GPa, and most preferably about 4.9 GPa. Paired with the tensile strength articulated above, the composite material may generally have a tensile modulus of elasticity, determined by the slope of the stress and strain relationship 2030, of greater than about 200 GPa and less than about 300 GPa, more preferably greater than about 225 GPa and less than about 275 GPa, and most preferably about 241 GPa. It is worth noting here that although the tensile strength and tensile modulus are all important characteristics of the fibers of the composite material, the key determinant on what makes the fiber suitable for the current invention will hinge on the strain to failure percentage. The strain to failure percentage, as referred to in the current exemplary embodiment, may generally be defined as the tensile strength of the fiber divided by the tensile modulus of elasticity of the fiber, as more specifically articulated in Equation (6) below.

$$\frac{\text{Tensile Strength}}{\text{Tensile Modulus of Elasticity}} = \frac{\text{Strain to Failure}}{\text{Percentage}} \quad \text{Eq. (6)}$$

The strain to failure percentage, as shown in the current exemplary embodiment in FIG. 20, and based on the tensile strength and tensile modulus of elasticity number above, may

generally be greater than about 1.0% and less than about 10.0%, more preferably greater than about 2.0% and less than about 8.0%, and most preferably about 2.5%.

Continuing the discussion about utilizing a composite material to form the face insert, FIG. 21 of the accompanying drawings shows an exploded view of a composite face insert 2120 in accordance with an exemplary embodiment of the present invention. More specifically, the exploded view of the face insert 2120 allows a better view of how the various orientations of the fiber within the composite face insert 2120 may be altered to affect the performance characteristics of the golf club head. The face insert 2120 shown in FIG. 21 may generally have a first layer 2141, a second layer 2142, a third layer 2143, a fourth layer 2144, a fifth layer 2145, a sixth layer 2146, a seventh layer 2147, an eighth layer 2148, or any number of layers deemed to be needed to construct the face insert 2120 all without departing from the scope and content of the present invention. In this current exemplary embodiment shown in FIG. 21, the face insert 2100 may have eight different layers, 2141, 2142, 2143, 2144, 2145, 2146, 2147, and 2148, each with a fiber orientated in a different orientation than the layer it immediately engages. More specifically, first layer 2141 may have the fibers orientated in a horizontal direction labeled as 0 degrees for ease of reference. Second layer 2142 may follow the first layer 2141 with fibers orientated in a diagonal direction more easily identified as +45 degrees. Third layer 2143 may follow the second layer 2142 with fibers orientated in a vertical direction more easily identified as 90 degrees. Fourth layer 2144, may follow the third layer 2143 with another layer of fibers orientated in a diagonal direction different from the second layer 2142, more easily identified as -45 degrees. Although eight different layers are shown in FIG. 21, subsequent layers 2145, 2146, 2147, and 2148 in this exemplary embodiment may follow the same orientation as the first four layers. In fact, any additional number of layers may be added in addition to what is shown in FIG. 21 to reach the required thickness without departing from the scope and content of the present invention, so long as it follows the structure set forth above in FIG. 21. Having this type of orientation may yield a composite face insert 2120 that has quasi-isotropic properties resulting in a face insert 2120 that is sufficiently strong enough to be able to withstand loads orientated in numerous different directions without failing.

FIG. 22 of the accompanying drawings shows a further alternative embodiment of the present invention wherein the face insert 2220 exhibit anisotropic properties. Anisotropy, as used in this current exemplary embodiment, refers to the directionally dependent strength of the composite face insert 2220 that results from the uniform orientation of the fibers within the composite face insert 2220. More specifically, as it can be seen from FIG. 22, the first layer 2241, the second layer 2242, the third layer 2243, the fourth layer 2244, the fifth layer 2245, the sixth layer 2246, the seventh layer 2247, and the eighth layer 2248 may all have fibers that run in a substantially vertical direction that is more easily identified as the 90 degree direction. Having an anisotropic composite face insert 2220 may further improve the performance of a golf club head by focusing the strength of the face insert 2220 along a direction that is subjected to the most stress while sacrificing some strength along other directions that tends to not generate as much stress. Within the design space of a golf club head, the majority of the stress is generated in a crown-sole direction; hence, by orienting the orientation of the fiber along that opposite direction, the striking face will have an increased modulus in the direction that has the shortest distance to absorb this stress. FIG. 22 only shows eight layers of

fiber within the composite face insert **2220** for illustration purposes, however, it should be noted that additional layers may be added to the face insert **2220** to reach the desired thickness of the face insert **2220** without departing from the scope and content of the present invention so long as it follows the structure set forth above in FIG. **22**.

In addition to the increased modulus along the desired direction, the face insert **2220** shown in FIG. **22** may also offer an additional performance benefit by reducing the number of plies of composite needed in the less stressed direction that spans from crown to sole, further removing unnecessary weight from the striking face of the golf club head. It should be noted here that although the current discussion relates more specifically to a composite based material being used for the face insert **2220**, the same concept of anisotropy may apply to metallic materials such as aluminum, magnesium, or even titanium all without departing from the scope and content of the present invention. More detailed discussion regarding the creation and the use of metallic anisotropy materials may be found in U.S. Pat. No. 6,623,543 to Zeller et al., the disclosure of which is incorporated by reference in its entirety.

FIG. **23** of the accompanying drawings shows a further alternative embodiment of the present invention wherein a different combination of fiber orientations yielding a face insert **2320** that is quasi-anisotropic. Quasi-anisotropy, as used in this current exemplary embodiment, refers to the directionally dependent strength of the composite face insert **2320** that results from an orientation of the composite fibers that favors one orientation over another orientation. More specifically, face insert **2320** may have a first layer **2341** with fibers orientated substantially vertical direction that is more easily identified as a 90 degree direction. Positioned behind the first layer **2341** is the second layer **2342** with fibers orientated in a substantially diagonal direction more easily identified as +45 degree. Third layer **2343**, being placed behind the second layer **2342** may have its fibers orientated that are similar to the fiber orientation of first layer **2341** being substantially vertical, reinforcing the strength of the face insert **2300** along the crown-sole orientation. Behind the third layer **2343** is a fourth layer **2344** having its fibers orientated in a substantially opposite diagonal direction than that of the second layer **2342**. The fourth layer **2344** may have fibers at a -45 degree orientation, signifying that its fiber orientation is perpendicular to that of the second layer **2342**. The fifth layer **2345**, placed behind the fourth layer **2344**, may have its fibers return to a substantially vertical orientation to further increase the strength of the face insert **2320** in the crown sole orientation. The sixth layer **2346**, as shown in the current exemplary embodiment, may generally have fibers orientated in a horizontal direction that can more easily identified as being at 0 degrees. Finally, the seventh layer **2347** of the composite face insert **2320** may revert back to having its fiber in the substantially vertical direction to further reinforce the strength along the heel toe direction.

The face insert **2320** shown in FIG. **23** may generally combine the quasi-isotropic benefits of the face insert **420** shown in FIG. **21** with the anisotropic benefits of face insert **520** shown in FIG. **22**. More specifically, because the face insert **2320** shown in FIG. **23** has fibers along several different orientations, it may help preserve the flexural stiffness of the face insert **2320** across various directions. However, having an increased number of layers that have fibers running in the vertical orientation allows the face insert **2320** shown in FIG. **23** to have increased the flexural stiffness of the face insert **2320** across the most heavily stressed direction. Once again, it should be noted that although FIG. **23** only shows seven

layers of composite fibers, numerous other numbers of layers may be used so long as it follows the structure set forth above in FIG. **23**.

FIG. **24** of the accompanying drawings shows an exploded perspective view of a golf club head **2400** in accordance with a further alternative embodiment of the present invention; wherein the golf club head **2400** further includes a plurality of cutouts **2474** to mate with a plurality of locking tabs **2472** to help secure the face insert **2420** onto the pocket **2422** of the body of the golf club head **2400**. In this exemplary embodiment of the present invention shown in FIG. **24**, the plurality of cutouts **2474** are placed on the crown **2404** and the sole **2406** portion of the golf club head **2400**, requiring the plurality of locking tabs **2472** to extend over the striking face portion of the golf club head **2400** into the body portion of the golf club head **2400**. The plurality of cutouts **2474** and the plurality of locking tabs **2572** are adapted to engage one another to provide a mechanical lock between the face insert **2420** and the golf club head **2400**, which serves to enhance bond between the aforementioned components. It should be noted that the pocket **2422**, in order to accommodate the shape of the face insert **2420**, may extend beyond the striking face into the crown **2404** and the sole **2406** of the golf club head **2400**.

The cross-sectional view of golf club head **2500** shown in FIG. **25** provides an alternative view of the golf club head **2400** shown in FIG. **24** by illustrating an assembled view of a golf club head **2500**. This assembled view of the golf club head **2500** shows how the plurality of cutouts **2574** and the plurality of locking tabs **2572** interact with one another to provide a structural mechanical lock to the face insert **2520**. This alternative embodiment of the present invention may be beneficial because the bond between the face insert **2520** and the body of the golf club head **2500** could be weak in situations where the face insert **2520** and the golf club head **2500** are comprised of different materials.

FIG. **26** of the accompanying drawings show a cross-sectional view of a golf club head **2600** in accordance with an alternative embodiment of the present invention, wherein the plurality of locking tabs **2672** have an alternate shape to provide an alternative mechanical lock between the face insert **2620** and the golf club head **2600**. FIG. **27** of the accompanying drawings also show a cross-sectional view of a golf club head **2700** in accordance with a further alternative embodiment of the present invention, wherein the plurality of locking tabs **2772** have a reverse locking shape to provide an alternative mechanical lock between the face insert **2720** and the golf club head **2700**.

FIG. **28** of the accompanying drawings shows an exploded perspective view of a golf club head **2800** in accordance with a further alternative embodiment of the present invention. More specifically, golf club head **2800** may generally have the plurality of cutouts **2874** located within the pocket **2822** of the golf club head **2800**. The pocket **2822**, as shown in FIG. **28**, may generally be confined to the striking face portion of the golf club head **2800** in order to provide a face insert **2820** that covers a significant portion of the striking face of the golf club head **2800**.

FIGS. **29**, **30**, and **31** of the accompanying drawings provide cross-sectional views of golf club heads **2900**, **3000**, and **3100** with varying configuration of the terminal ends of the face insert **2920**, **3020**, and **3120**. In one embodiment shown in FIG. **29**, the terminal ends of the face insert **2920** are folded over the cavity **2922** towards the center of the golf club head **2900** to help secure the face insert **2920** onto the golf club head **2900** itself. In another embodiment shown in FIG. **30**, the terminal ends of the face insert **3020** are folded away from

21

the central portion of the golf club head **3000** towards the crown **3004** and the sole **3006** of the golf club head **3000**. Finally, in another embodiment of the present invention shown in FIG. **31**, any one of the terminal end may be folded towards the center of the golf club head **3100** while the other terminal end may be folded away from the center of the golf club head **3100**. It should be noted that in order to provide such a pliable face insert **2920**, **3020**, and **3120**, the material used may generally be a composite type material. In order to configure the pliable face insert **2920**, **3020**, and **3120** into their respective positions behind the pocket **2922**, **3022**, and **3122**, the golf club head **2900**, **3000**, and **3100** may generally need to be formed using bladder molding techniques, curing the composite face insert **2920**, **3020**, and **3120** in its desired position.

FIG. **32** of the accompanying drawings provides an exploded perspective view of a golf club head **3200** in accordance with a further alternative embodiment of the present invention. More specifically, golf club head **3200** may utilize a plurality of rods **3276** within the pocket **3222** to support the face insert **3220**. Utilizing rods **3276** may be a beneficial alternative to the embodiments discussed above as it further saves weight from the frontal portion of the golf club head **3200**. In addition to the weight savings advantages, utilizing a plurality of rods **3276** may offer an easier way to construct the face insert **3220**. More specifically, the plurality of rods **3276** may allow the composite type material to be wrapped around the plurality of rods **3276** similar to a towel rack. Because a composite type material may generally be relatively pliable before it is cured, the wrapping of such a composite material to form the face insert **3220** may have simplified manufacturing advantages. FIG. **33** of the accompanying drawings shows a cross-sectional view of a golf club head **3300** in accordance with an exemplary embodiment of the present invention wherein a plurality of rods **3376** formed within the pocket **3322** may allow for a composite type face insert **3320** to be wrapped around the plurality of rods **3376**.

FIGS. **34** and **35** of the accompanying drawings provide an exploded perspective view and a cross-sectional view of golf club heads **3400** and **3500** in accordance with a further alternative embodiment of the present invention. More specifically, golf club heads **3400** and **3500** may generally have the central portion of the pocket **3422** and **3522** supported by a metallic material to provide structural support to the hollow central portion shown in FIG. **33**. This additional structural support may be beneficial to the performance of the golf club head **3400** and **3500**, especially when it impacts a golf ball at a high rate of speed.

Recognizing that the composite type material used to form the face insert of a golf club head may generally be relatively brittle; the present invention may utilize a cover layer to protect the brittle face insert. More specifically, all face inserts discussed above may be covered with a cover layer to protect the brittle face insert without departing from the scope and content of the present invention. Cover layer, as discussed above, may generally be a metallic material such as steel, titanium, or even aluminum to provide more support to the face insert. These cover layers may generally have a Vickers hardness of greater than about 100 without departing from the scope and content of the present invention. Because the face insert that is made out of lightweight secondary material may generally be softer, it could be blemished more easily from repeated impact with a golf ball. Having a cover layer will reduce cosmetic blemishes from appearing on the external surface of the golf club head, making the golf club head more aesthetically appealing.

22

With respect to the cover layer discussed above, the bonding of the cover layer with the face insert may generally utilize methodologies such as co-molding, which would require the material of the cover layer to have a low coefficient of thermal expansion, especially if a composite type material is used to form the face insert. Hence, the material used to form the cover layer may generally be an invar or kovar type material having a coefficient of thermal expansion of less than about 30 micrometers/(meters\*° C.) without departing from the scope and content of the present invention

Some embodiments of the present invention utilize materials that are not suitable for withstanding the high temperatures required for the welding processes used to attach the face to the golf club head. Thus, the present invention provides a method for attaching a face to the body of a golf club head without the need for excessive heat. Referring now to FIG. **36A**, a cross-sectional view of a portion of a golf club head **3600** in accordance with an embodiment of the present invention is shown. Club head **3600** includes a crown **3604**, a sole **3606**, and a multi-material face **3620**. Locking tabs **3610** and **3612** provide a mechanical lock between face **3620** and crown **3604** and sole **3606**. FIG. **36D** shows an alternative location and shape for locking tabs **3610** and **3612**. Adhesive is optionally applied at the interface between face **3620** and locking tabs **3610** and **3612** to adhesively connect face **3620** to crown **3604** and sole **3606**.

As illustrated in FIGS. **36B** and **36E**, in a particular embodiment, multi-material face **3620** comprises an outer layer **3622**, a lightweight layer **3624**, an additional layer **3626**, and a mechanical locking or clamping assembly. The mechanical locking or clamping assembly includes a male fastener **3630** projecting from the inner surface of outer layer **3622**, penetrating lightweight layer **3624** and additional layer **3626**, and secured by a female fastener **3640**. Preferably, multi-material face **3620** includes multiple mechanical locking or clamping assemblies located about the perimeter of the face. Suitable mechanical locking or clamping assemblies include, for example, a screw or bolt secured by a nut or rivet, and can be formed from any suitable material, such as titanium, aluminum, or a composite. Each male fastener **3630** is affixed to the inner surface of outer layer **3622**, for example, by friction welding or casting. Alternatively, as illustrated in FIG. **36C**, male fastener **3630** penetrates outer layer **3622** such that it is visible from the exterior of the club head. Adhesive is optionally applied at the interface between the layers of the multi-material face.

In a particular embodiment, lightweight layer **3624** is formed from a material having a density lower than that of outer layer **3622**. In a particular aspect of this embodiment, lightweight layer **3624** is formed from a material selected from aluminum, particularly an aluminum material having a density of about 2.7 g/cm<sup>3</sup>; magnesium, particularly a magnesium material having a density of about 1.738 g/cm<sup>3</sup>; a composite type material having a density of less than about 2.7 g/cm<sup>3</sup>, or a density of about 1.70 g/cm<sup>3</sup> or less; or a polymer composition having a density of less than about 2.7 g/cm<sup>3</sup>, or a density of about 1.70 g/cm<sup>3</sup> or less. In embodiments wherein lightweight layer **3624** is formed from a composite or polymer composition, the lightweight layer can be placed over the male fasteners prior to or after curing.

It should be noted that although FIGS. **5**, **11-19**, **24-35**, and **36A-36E** all show distinct features and geometries for the face insert in combination with their respective backing portion having their own distinct features and geometries, the various features and geometries of the various components

can be interchanged to create different designs and achieve different goals all without departing from the scope and content of the present invention.

Other than in the operating example, or unless otherwise expressly specified, all of the numerical ranges, amounts, values and percentages such as those for amounts of materials, moment of inertias, center of gravity locations, loft, draft angles, various performance ratios, and others in the aforementioned portions of the specification may be read as if prefaced by the word "about" even though the term "about" may not expressly appear in the value, amount, or range. Accordingly, unless indicated to the contrary, the numerical parameters set forth in the above specification and attached claims are approximations that may vary depending upon the desired properties sought to be obtained by the present invention. At the very least, and not as an attempt to limit the application of the doctrine of equivalents to the scope of the claims, each numerical parameter should at least be construed in light of the number of reported significant digits and by applying ordinary rounding techniques.

Notwithstanding that the numerical ranges and parameters setting forth the broad scope of the invention are approximations, the numerical values set forth in the specific examples are reported as precisely as possible. Any numerical value, however, inherently contains certain errors necessarily resulting from the standard deviation found in their respective testing measurements. Furthermore, when numerical ranges of varying scope are set forth herein, it is contemplated that any combination of these values inclusive of the recited values may be used.

It should be understood, of course, that the foregoing relates to exemplary embodiments of the present invention

and that modifications may be made without departing from the spirit and scope of the invention as set forth in the following claims.

What is claimed is:

1. A golf club head comprising a face and a body portion, the face comprising:
  - a outer layer at least partially formed from a titanium material having a density of from about 4.0 g/cm<sup>3</sup> to about 5.00 g/cm<sup>3</sup> and having a plurality of male fasteners projecting from an inner surface thereof;
  - a lightweight layer penetrated by the plurality of male fasteners and having a thickness of greater than about 0.2 mm and less than about 2.0 mm and at least partially formed from a composite material having a density of 1.70 g/cm<sup>3</sup> or less;
  - an additional layer penetrated by the plurality of male fasteners; and
  - a plurality of female fasteners, each female fastener affixed to one of the male fasteners.
2. The golf club head of claim 1, wherein the face additionally comprises an adhesive coating disposed between the outer layer and the lightweight layer.
3. The golf club head of claim 1, wherein the face is adhesively connected to the body portion.
4. The golf club head of claim 1, wherein the male fasteners are formed from a material selected from the group consisting of titanium, aluminum, and composites.
5. The golf club head of claim 1, wherein the male fasteners are friction welded to the inner surface of the outer layer.
6. The golf club head of claim 1, wherein at least one of the male fasteners extends to the outer surface of the outer layer.

\* \* \* \* \*