

Jan. 19, 1954

M. MACCAFERRI

2,666,240

CLIP FOR CLOTHES RACKS

Filed Feb. 19, 1951

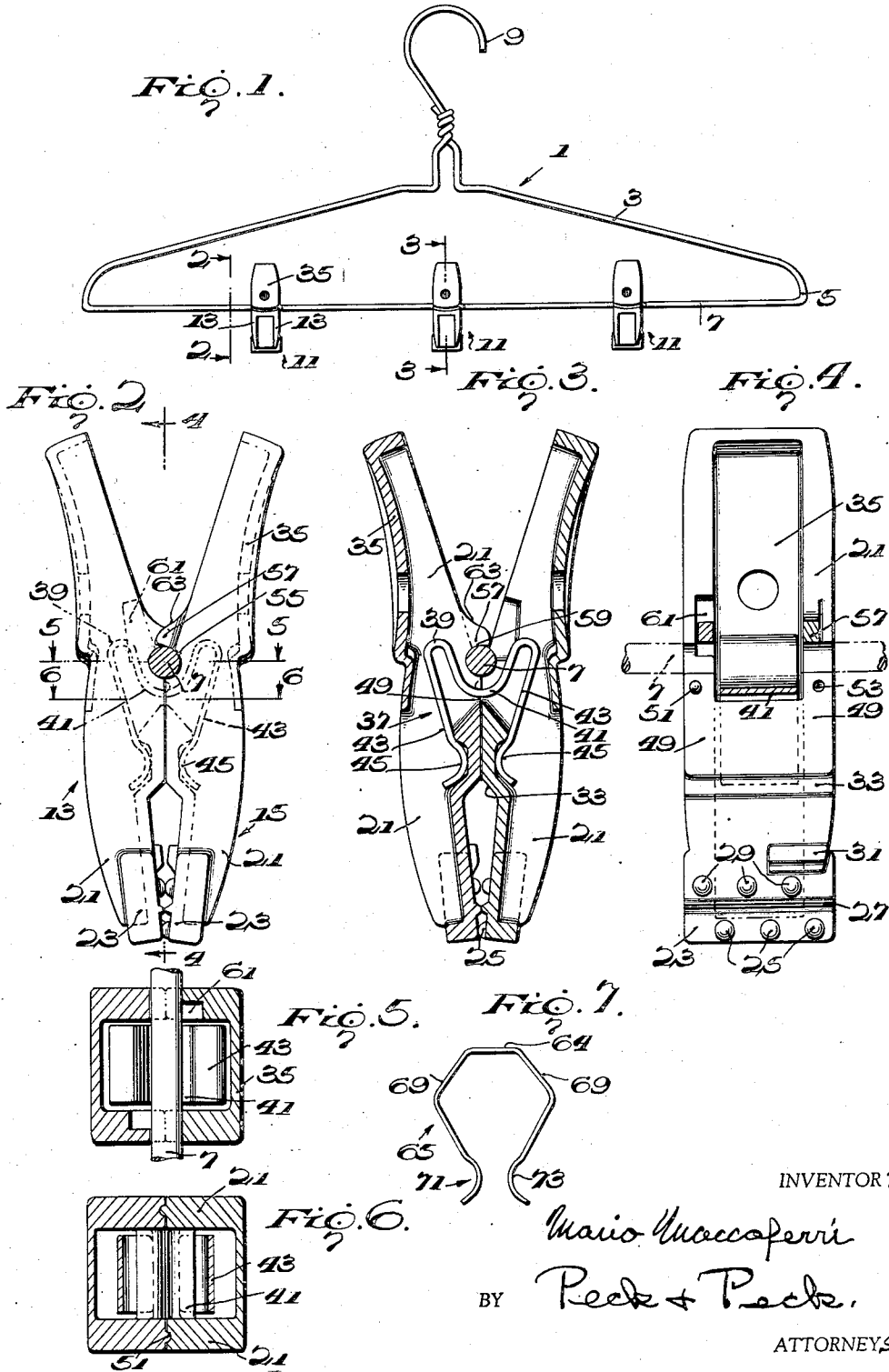

INVENTOR:

Maio Maccaferri

BY

Reed & Reed,

ATTORNEYS.

UNITED STATES PATENT OFFICE

2,666,240

CLIP FOR CLOTHES RACKS

Mario Maccaferri, Rye, N. Y.

Application February 19, 1951, Serial No. 211,639

4 Claims. (Cl. 24-137)

1

This invention relates broadly to clothes clips and in its more specific aspects it relates to clothes clips adapted to be supported from and combined with a horizontal rod on a clothes rack; and the nature and objects of the invention will be readily understood by those skilled in the arts to which it relates in the light of the following explanation and detailed description of the accompanying drawings illustrating what I at present believe to be the preferred embodiments and mechanical expressions of my invention from among various other forms, arrangements, combinations and constructions, of which the invention is capable within the spirit and scope thereof.

The clothes clip of this application constitutes an improvement on the clothes clip shown in my Patent 2,461,333 issued February 8, 1949, for Clothes Pin and also constitutes an improvement over the clothes clip disclosed in my pending patent application Serial No. 75,120, filed February 8, 1949, for Clips for Clothes Racks, now Patent No. 2,583,784, dated January 29, 1952.

The clips of this character with which I am familiar must be mounted on and removed from the horizontal clip supporting rod of a clothes rack through one side of the clip. This method of mounting the clips on the horizontal supporting rod of a clothes rack requires removal of the horizontal rod from its clothes rack supporting structure so that one or more clips may be slid sidewise on the end of the horizontal rod. The necessity of mounting the clips sidewise on the rod at an end thereof has necessitated constructing the clothes rack so that the horizontal rod may be disconnected at one end from the rack, and of course has added to the expense of manufacturing the clothes rack and made the mounting of the clips more difficult. I have overcome this difficulty and disadvantageous necessity of prior art structures by so forming my clothes clip that it may be mounted on and removed from the horizontal rod through the diverged handle end of the clip, that is, the clip may be fastened on the rod by disposing the rod between the divergent handle portions of the jaws of the clip. I have therefore eliminated the necessity of forming the clothes rack so that at least one end of the horizontal rod must be disconnected therefrom for sidewise mounting of the clips thereon. It will be evident that this improvement is highly advantageous for it permits the user of the combination clothes rack and clothes clip to add additional clips to the horizontal rod with practically no manipulation of any of the elements of the organization.

2

My clips may be mounted by a radial association with the rod rather than by an axial association therewith due to a novel type of biasing spring and jaw construction which I have devised.

The improved clip also includes novel means for guiding and constraining the jaws in their pivoting action and for removably maintaining the clip in position mounted on the horizontal rod.

I have also provided novel gripping means which are so formed on the jaw surfaces that the configuration of every jaw gripping surface is the same and when two jaws are assembled into an operative unit will properly mate to provide the desired gripping surface. It will be appreciated that such a construction greatly facilitates the assembly of the clips, for it is not necessary that one jaw having a certain gripping surface be assembled with another jaw having a different gripping surface.

The improved clip in one form also embodies a novel type of biasing spring whereby certain advantages of construction, assembly and operation are obtained.

With the foregoing general objects, features and results in view, as well as certain others which will be apparent from the following explanation, the invention consists in certain novel features in design, construction, mounting and combination of elements, as will be more fully and particularly referred to and specified hereinafter.

Fig. 1 is a view in elevation of the clips mounted on the horizontal rod of a clothes rack.

Fig. 2 is a view taken on line 2-2 of Fig. 1.

Fig. 3 is a view taken on line 3-3 of Fig. 1.

Fig. 4 is a view taken on line 4-4 of Fig. 2.

Fig. 5 is a view taken on line 5-5 of Fig. 2.

Fig. 6 is a view taken on line 6-6 of Fig. 2.

Fig. 7 is a view in side elevation of another form of biasing spring.

Referring to the accompanying drawings wherein I have used the numeral 1 to designate a clothes rack which may comprise a horizontal portion 3 having depending end members 5 between the lower ends of which extends a horizontal clothes clip supporting rod 7 of cylindrical contour. The clothes rack may also include an upstanding hook member 9 by means of which the organization may be suspended from a clothes bar or the like. The clothes rack 1 may be constructed of plastic or any other suitable material and of course may take forms differing from that illustrated in the drawings, however, it is desir-

able to form the horizontal clothes clip supporting rod 7 of metal.

The horizontal rod 7 is adapted to removably mount and support any number of clothes clips 11. Organizations of this character are particularly advantageous and are used extensively for the hanging support of ladies' skirts and men's trousers and other garments, and it will be apparent that it is desirable that the clothes clips 11 be mounted on the horizontal rod of the clothes rack in such manner that they may be moved longitudinally therealong to conform to the varying widths of the garments being supported.

The clothes clips 11 may be made in any suitable way and are preferably formed of plastic material. Each clip consists of a pair of clamping jaws 13 and 15 and each clamping jaw is of the same structure. A clamping jaw is provided with spaced side flanges 21 having a gripping surface 23 extending between the flanges from the longitudinal edges thereof. The gripping surface is provided with a series of half ball spaced projections 25 adjacent the end of the gripping surface, and these projections start at one side of the surface but do not extend to and are spaced from the other side. Rearwardly spaced relative to the projection 25 is a transverse rib 27 and rearwardly spaced from the rib I provide a further series of spaced half ball projections 29 which start at the other side of the gripping surface from that at which projections 25 start, and the series of projections 29 are spaced from the other side of the surface. It will thus be appreciated that the projections 25 and 29 are not in alignment. A rib 31 is formed on the gripping surface rearwardly spaced relative to the series of projections 29 and this rib extends approximately halfway across the gripping surface.

An offset portion 33 extends between the flanges rearwardly of the gripping surface.

I provide a finger receiving portion 35 which bridges the flanges at the rear or handle end of the jaw. This finger receiving portion extends from the other longitudinal edges of the flanges from those from which the gripping surface and the offset portion extend. Consideration of the drawings discloses that this structural arrangement of the jaws provides an opening within the area defined by the flanges and between the offset portion and the finger receiving portion.

A clothes clip includes a pair of jaw members pivotally mounted together for rocking movement to separate the clamping jaws for receiving therebetween material to be suspended from the clip.

The clamping portion of the jaws are urged together by an M spring 37 which includes a base 39 having a re-entrant portion 41 therein, the base connecting the upper ends of a pair of legs 43 each of which has a corrugation 45 adjacent to the lower end thereof. When two jaws are in assembled position the M spring 37 is operatively associated with the jaws connecting them together and constantly urging the jaw portion together in clamping position. It will be recognized that a leg extends through the opening in each jaw and presses against the offset portion.

With the two jaws mounted as described forming a unitary structure the clamping jaws may be separated by forcing the diverging handle portions toward one another whereupon a rocking or pivoting action of the two jaws takes place.

Each jaw component of a unitary clip is formed with a plane surface 49 on each flange edge, and adjacent the rear end of such plane surface of one flange I provide a half ball projection 51

and adjacent the rear end of the plane surface on the other flange edge I form a half ball recess 53. Rearwardly of the plane portions of the flange edges I provide substantially semi-circular recesses or cutout sections 55 and rearwardly of one of such semi-circular cutout sections on one flange edge I provide an upstanding or upright finger or lug member 57 having its forward edge arcuately shaped as at 59 to form in effect a continuation of the semi-circular cutout section. On the other flange edge rearwardly of the cutout section, instead of forming the upstanding finger or lug 57 I cut a section of the edge out as at 61.

When two jaw components are operatively associated to form the clip of this invention it will be apparent that the jaws are inverted relative to each other, that is the gripping surface of one jaw faces in a direction opposite to that of the gripping surface of the other jaw. As pointed out hereinabove, the structure of each jaw component is exactly the same so that when they are inverted the positions of the various elements will be oppositely disposed. For instance the series of half ball projections on the gripping surfaces are so positioned that the projections of one jaw will fall between the projections of the other jaw and hence a secure and firm gripping surface is provided so that material clamped between the jaws will be maintained suspended from the clips. Similarly, the transverse ridges which extend halfway across each gripping area will be in alignment providing additional gripping means.

When the jaws are rocked by means of the divergent handles the pivoting action will take place on surfaces 49 of the flanges and will be guided and aided by the action of the half ball projections 51 seating in the half ball recesses 53. Due to the construction wherein one flange of one jaw has a recess and the opposing flange of the other jaw has a projection it will be appreciated that when two jaws are assembled in operative clip forming position a projection will be positioned for seating in a recess. In like manner when two jaws are operatively associated in clip forming position the cutout portions 61 on one flange of one jaw will be disposed opposite the finger or lug 57 on the other jaw so that when the jaws are rocked a finger will rock into and out of a cutout portion. This movement of the fingers into and out of the cutout portions as the jaws are rocked in the operation of the clip guides and constrains the jaws to maintain them in proper relative positions so that they will not be laterally offset with respect to one another.

When the clip is mounted on the horizontal rod of a clothes rack the rod is forced between the divergent handle portion of the jaws and engages the inclined rear surfaces 63 of the fingers 57 to thereby spread the handle ends of the jaws sufficiently far apart to permit the entry of the horizontal rod into the semi-circular recesses or cutout portions 55 within the flanges of the jaws. When two jaw members are connected together by means of the M spring it will be appreciated that the semi-circular recesses in each flange provide complementary surfaces which define a space for receiving a horizontal supporting rod, and that this space is on the other side of the pivotal connection (the sections 49 of the flanges) from the clamping jaws. With the clip operatively mounted and suspended from the horizontal rod of the clothes rack it will be apparent that it is received within the re-entrant portion of the base of the M spring and when in this position it is maintained therein by the fingers

57 which effectually close the rear opening at the rear upper edges of the semi-circular cutout portions. It will be recognized that this novel and unique construction permits the attachment of a clothes clip on the horizontal rod by moving the clip radially toward the rod and when the rod has passed the fingers the clip will be removably maintained on the rod.

Consideration of the drawings illustrates that the re-entrant portion of the biasing spring is aligned with the rod receiving spaces defined by the semi-circular cutout portion in the flanges of the jaws, so that the horizontal rod may extend through the spaces and the re-entrant portion. It is also evident that the rod may be released from the unit through the divergent handle end thereof without disturbing or engaging the M biasing spring.

The clips of this invention may be moved axially of the horizontal rod when the clamping jaws are in closed position and are locked on the rod against axial movement therealong when the jaw portions of the clips are in separated position. This locking action is generally the same as that described in my pending application Serial No. 75,120 and results from a reduction in the diameter of the area defined by the semi-circular cutout portions through which the rod extends so that a binding or wedging action on the rod results.

In Fig. 7 of the drawings I have disclosed a further form of biasing spring which I have designated in its entirety by the numeral 65. This biasing spring 65 is a pentagon type spring and includes a base section 64 and side portions 69 having five sides from the lower of which legs 71 extend which are bent towards each other at 73 forming in effect a corrugation at this point. It will be observed that the five sided body portion of this spring is relatively larger or longer than the legs. This spring has been found to be exceptionally useful and advantageous when used with a clip generally similar to that illustrated in my pending patent application Serial No. 75,120.

What I claim is:

1. A clip including, in combination, a pair of members provided intermediate the opposite ends thereof with facing arcuate recesses therein defining a support rod receiving space therebetween; clamping jaws formed by said members, respectively, at one side of said recesses; outwardly divergent handles formed by said members at the side of said recesses opposite said clamping jaws; a spring unit mounted on said members adapted to continuously bias the said members to position closing said clamping jaws; said spring unit including opposite spring legs extending along and engaged with said clamping jaws, respectively, and a base common to said spring legs extending between said members across and spaced from said recesses at the side thereof opposite said handles; each of said members being provided with a finger extending inwardly therefrom to the opposite member and across and closing the outer, handle side of said rod receiving space formed between said recesses; and each of said members being formed with an opening therein aligned with and freely movably receiving therein the inwardly extending finger of the other of said members.

2. A clip including, in combination, a pair of members provided intermediate the opposite ends thereof with facing arcuate recesses therein defining a space therebetween adapted to receive therethrough a support rod for pivotally sup-

porting said members thereon; clamping jaws formed by the said members at one side of said recesses; outwardly divergent handles formed by said members at the side of said recesses opposite said clamping jaws; a spring unit mounted on said members and being adapted to continuously bias said members in directions to bring together and close said clamping jaws; each of said members being provided with a finger extending inwardly therefrom to the opposite member across and closing the outer side of the rod receiving space formed between said recesses in all operative positions of said members; and each of said members at the portion thereof opposite the inwardly extending finger of the other of said members being formed to freely pass such finger in non-engaging relation for movements of said finger relative thereto in clamping jaw opening and closing operations of said members.

3. A clip including, in combination, a pair of members provided intermediate the opposite ends thereof with facing complementary bearing surfaces defining therebetween a space adapted to receive therethrough a rod for pivotally mounting said members thereon; said members being formed to provide facing complementary clamping jaws at one side of said bearing surfaces; said members being formed to provide outwardly divergent handles at the side of said bearing surfaces opposite said clamping jaws; a spring unit mounted on said members adapted to continuously bias said members to position closing said clamping jaws; each of said members being provided with a finger immediately adjacent said bearing surface in such member extending inwardly therefrom to the opposite member in position across and closing the outer, handle side of said rod receiving space formed between said complementary bearing surfaces; each of said members being formed with a recess therein facing and aligned with the said inwardly extending finger of the other of said members with such finger having non-bearing engagement with the said other member; and the outer side edge of each of said fingers being inclined inwardly from the member on which mounted toward the opposite member to thereby provide outwardly divergent camming surfaces located between said handles at the outer, handle side of said bearing surfaces.

4. A clip including, in combination, a pair of members pivotally joined at the portions thereof intermediate the opposite ends of said members; said members at one side of said pivotally joined intermediate portions being formed to provide facing complementary clamping jaws and at the opposite side of said intermediate portions being formed to provide outwardly divergent handles; a spring unit mounted on said members adapted to continuously bias the members to position closing said clamping jaws; each of said handles having longitudinal edge flanges thereon extending therefrom inwardly toward the said longitudinal edge flanges of the opposite of said handles; a pair of complementary, facing bearing surfaces formed adjacent the inner ends, respectively, of the facing flanges at opposite sides of said handles to define therebetween spaces aligned transversely of said members for receiving therethrough a rod for pivotally mounting said members thereon; fingers provided adjacent the inner ends of said flanges outwardly of said bearing surfaces at opposite sides, respectively, of said handles with each of said fingers being positioned immediately adjacent the bear-

7

ing surface in that flange of said handle and extending inwardly therefrom to the opposite of said members in position across and closing the outer handle side of the rod receiving space formed between such bearing surface and the bearing surface in the facing flange of the other of said handles; and each of said handles being formed with a recess therein opposite the inwardly extending finger on the other of said handles with such finger being freely received and movable in such recess in non-bearing engagement with the said handle.

MARIO MACCAFERRI.

References Cited in the file of this patent

UNITED STATES PATENTS

Number	Name	Date
1,080,013	Landin	Dec. 2, 1913

8

Number	Name	Date
1,085,461	Michaels	Jan. 27, 1914
1,091,413	Wilkins	Mar. 24, 1914
2,442,295	Kuendel	May 25, 1948
2,471,606	Burns	May 31, 1949
2,496,109	Terry	Jan. 31, 1950
2,525,985	Weymouth	Oct. 17, 1950
2,531,003	Slaker	Nov. 21, 1950
2,569,371	Cohen	Sept. 25, 1951
2,583,784	Maccaferri	Jan. 29, 1952

FOREIGN PATENTS

Number	Country	Date
598,151	Great Britain	Feb. 11, 1948

15