

United States Patent

Nakajima et al.

[15] 3,646,764

[45] Mar. 7, 1972

[54] **AIR POLLUTION PREVENTIVE SYSTEM FOR MOTOR VEHICLES**

[72] Inventors: **Yasuo Nakajima**, Yokosuka; **Yoshimasa Hayashi**, Yokohama, both of Japan

[73] Assignee: **Nissan Motor Company, Limited**, Yokohama, Japan

[22] Filed: **Apr. 27, 1970**

[21] Appl. No.: **32,248**

[30] **Foreign Application Priority Data**

May 30, 1969 Japan.....44/41638

[52] U.S. Cl.60/279, 60/286, 123/119 A

[51] Int. Cl.F01n 3/12, F02m 25/06

[58] Field of Search.....60/29, 30; 123/119 A, 119 F

[56] **References Cited**

UNITED STATES PATENTS

2,158,424	5/1939	Hunt.....	123/119 F
2,317,582	4/1943	Bicknell.....	123/119 A
2,624,325	1/1953	Fricke.....	123/119 F

2,722,927	11/1955	Cornelius.....	123/119 A
3,209,531	10/1965	Morris.....	60/30
3,368,345	2/1968	Walker.....	60/30
3,457,906	7/1969	Daigh.....	123/119 A
3,481,144	12/1969	Morrell.....	60/30
3,513,816	5/1970	Daigh.....	123/119 A

Primary Examiner—Douglas Hart

Attorney—Robert E. Burns and Emmanuel J. Lobato

[57] **ABSTRACT**

A vehicular air pollution preventive system with a unit or units constructed to reduce the quantity of nitrogen oxides and/or hydrocarbons under the control of means responsive to the engine temperature, and either one of the intake manifold vacuum, vehicle or engine speed, or a combination of any of these, which system includes control means responsive to a relatively cool temperature of the engine to deactuate the unit for reducing the quantity of nitrogen oxides in the exhaust gases and to actuate the unit for reducing hydrocarbons, and responsive to a relatively hot temperature of said engine to actuate the unit for reducing the quantity of nitrogen oxides and to deactuate the unit for reducing hydrocarbons.

3 Claims, 4 Drawing Figures

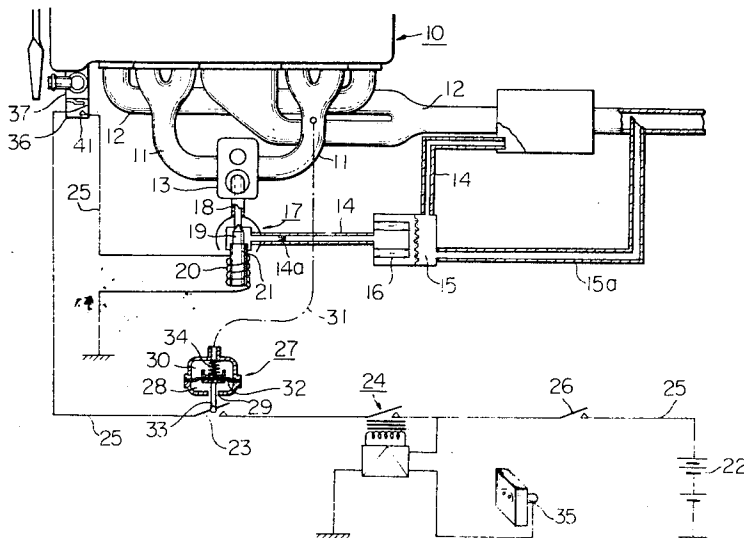

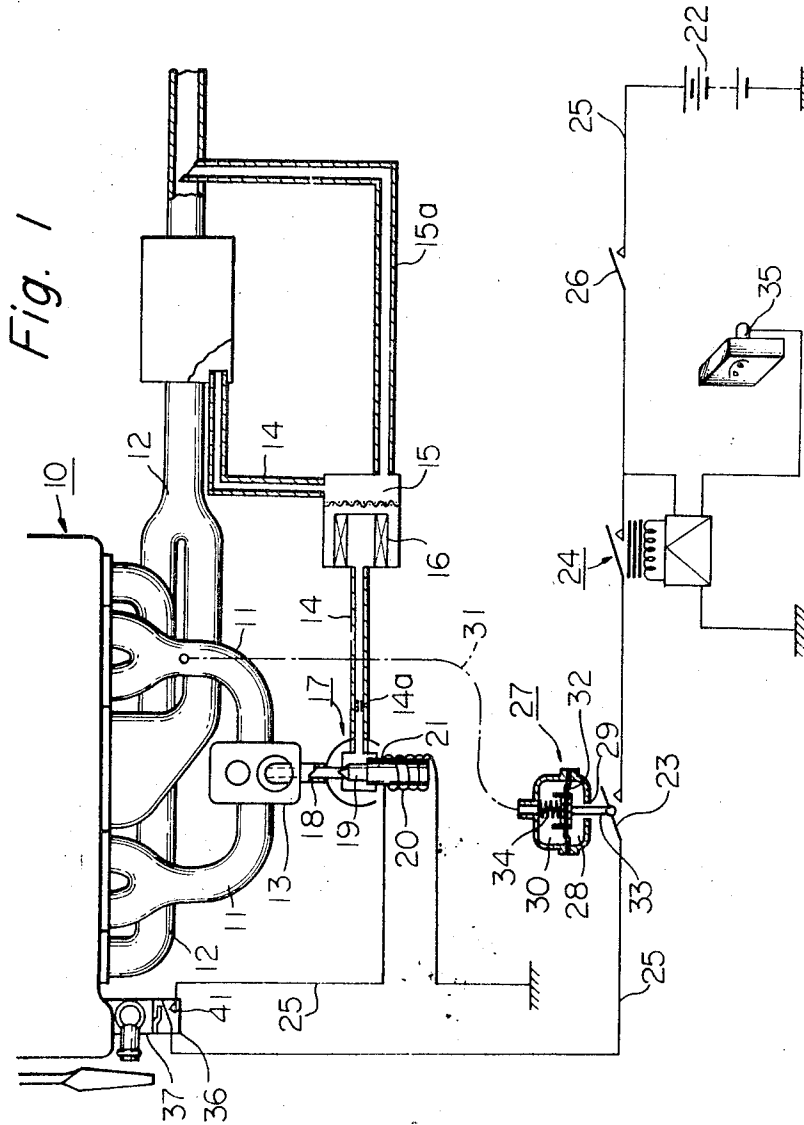

Fig. 2

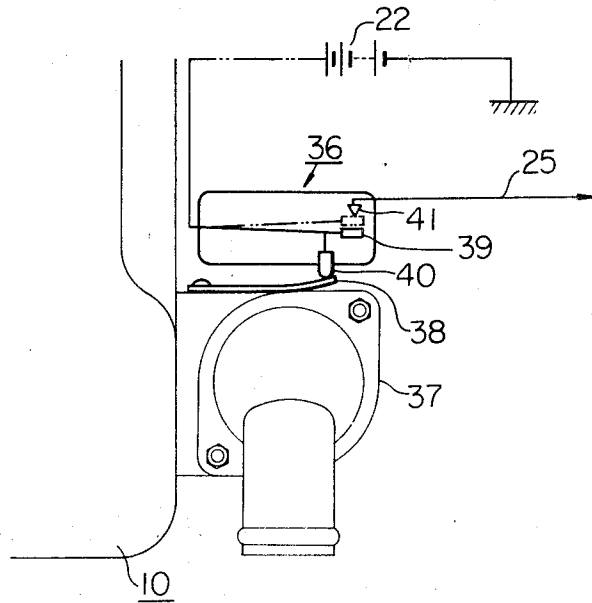
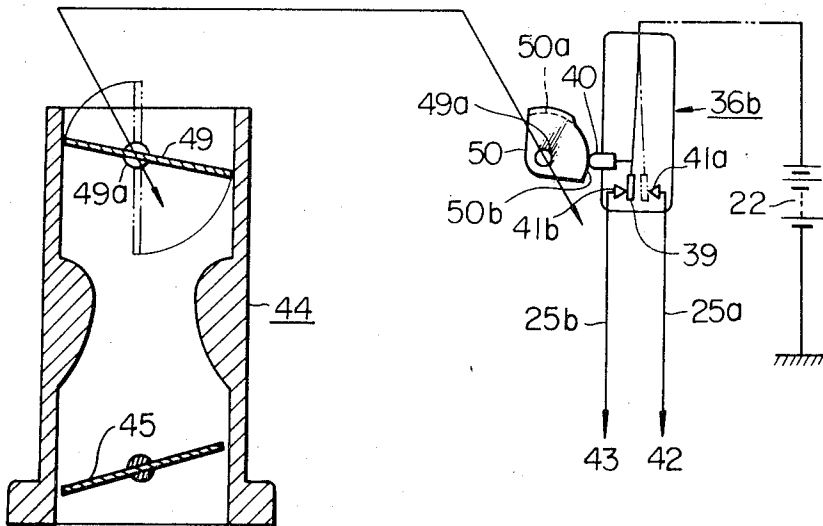
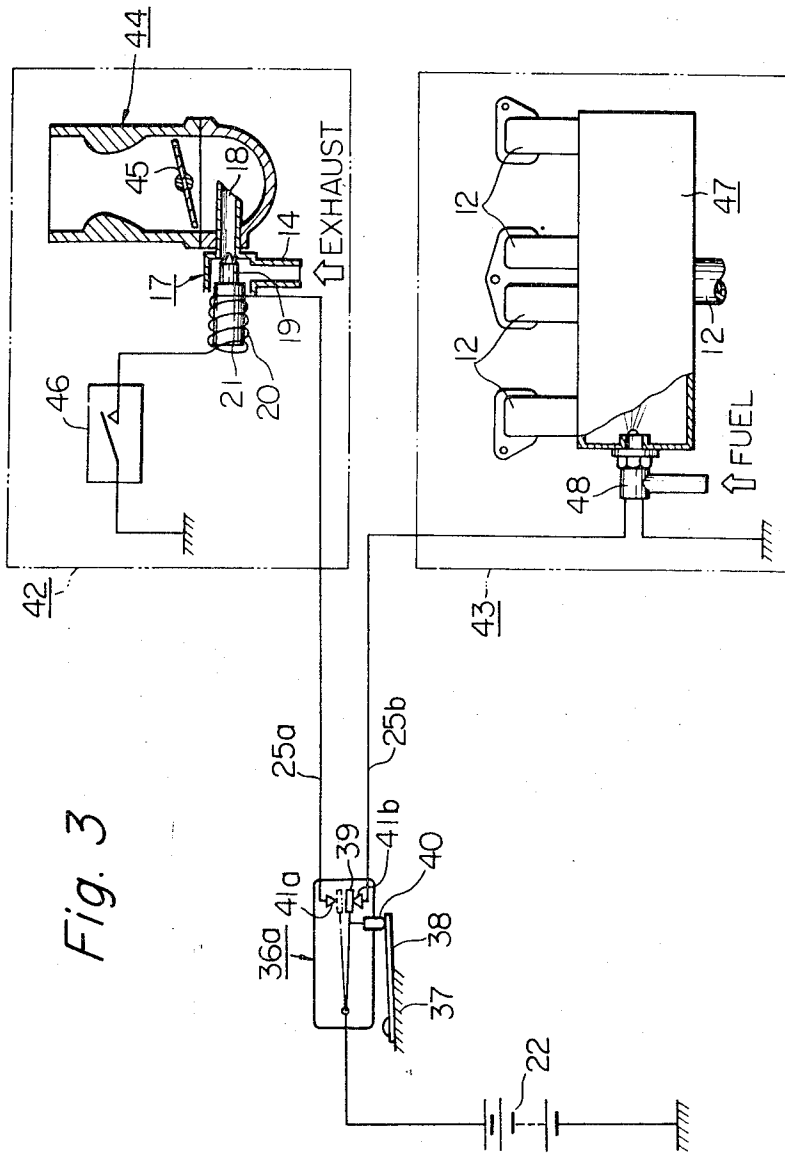

Fig. 4





AIR POLLUTION PREVENTIVE SYSTEM FOR MOTOR VEHICLES

This invention relates to an air pollution preventive system of a motor vehicle which is driven by an internal-combustion engine.

Various vehicular air pollution preventive systems have been proposed with a view of reducing the quantity of concentration of noxious air pollutants contained in the engine exhaust gases, including exhaust gas recirculation devices and afterburners.

The exhaust gas recirculation device is adapted to have the engine exhaust gases recirculated to the intake manifold of the engine whereby the nitrogen oxides contained therein are prevented from being formed and discharged to the open air. In the afterburner, on the other hand, the exhaust gases are subjected to recombustion anywhere in the exhaust system so that the small quantities of fuel remaining unconsumed are burned before they are emitted. All these air pollution preventive systems of known type are, in any event, constructed in a manner to be operable without or with little respect to the varying driving conditions of the vehicle.

As is well known in the art, however, the noxious pollutants are produced in different quantities depending upon the running conditions of the engine and the quantity of nitrogen oxides in the exhaust gases emitted when the engine is being warmed up is so small as to cause no serious air pollution problem. It should also be noted that the quantity of combustion is degraded and the engine operation performance deteriorated when the exhaust gases are drawn into the combustion chambers before the operating temperature of the engine is reached. Thus, it is preferable that the exhaust recirculation system be kept inoperative when the engine is driven cold.

With the engine cold, the temperature in the exhaust manifold is so low that substantially no oxidation of the unburned combustible compounds takes place and, as the consequence, a large amount of hydrocarbons is emitted.

Thus, it is necessary for reducing the quantity of hydrocarbon in the engine exhaust gases to have the air pollution preventive system such as an afterburner kept operative during cold driving of the engine. Since, the quantity of hydrocarbons in the exhaust gases decreases sharply as soon as the operating temperature of the engine is reached, it is not necessary to have the afterburner kept operative after the engine has been sufficiently warmed up. Continued actuation of the afterburner even after the engine is fully warmed up would result in waste of electric power consumed to keep the afterburner operative.

Thus, an object of the invention is to provide a vehicular air pollution preventive system of the type adapted to be activated when the engine is driven cold.

Another object is to provide an air pollution preventive system having two separate control means, one for preventing the formation and emission of nitrogen oxides and kept inoperative until the operating temperature of the engine is reached and the other for completing the combustion and thus preventing the emission of hydrocarbons and kept operative during cold driving.

The temperature at which the engine is being driven is sensed by a bimetal member which is mounted on the engine, e.g., at a position wherein it is immersed in the engine cooling water; or, if desired, the engine temperature can be approximated by the angular position of a choke valve positioned in the engine carburetor.

In the drawings:

FIG. 1 is a schematic view illustrating an air pollution preventive system embodying the invention;

FIG. 2 is also a schematic view illustrating an example of a thermostatic switch used in the system of FIG. 1;

FIG. 3 is similar to FIG. 1 but shows an air pollution preventive system in a modified form; and

FIG. 4 is a schematic view illustrating another example of a thermostatic switch for controlling the air pollution preventive system to which the invention is directed.

It may be noted before entering into a detailed description of the invention that the air pollution preventive system herein disclosed is operable in response to any operating variables of the vehicle including the intake manifold vacuum, vehicle or engine speed, angular position of the carburetor throttle valve (or effective throttle area), or combination of any of these, as far as the operating variables represent particular driving conditions of the engine.

An example of an air pollution preventive system to which this invention is directed is illustrated in FIG. 1, the system being used in combination with a usual internal-combustion engine which is generally represented by numeral 10. The engine 10 has, as is customary, an intake manifold 11 and an exhaust manifold 12. The intake manifold 11 is connected to an engine carburetor (not shown) by a mounting flange 13, while the exhaust manifold 12 leads to an exhaust pipe (not shown) to discharge the exhaust gases emitted from the engine 10.

The air pollution preventive system as shown is constructed as an exhaust recirculation system which is controlled by the combination of intake manifold vacuum and engine or vehicle speed. The system has an exhaust gas recirculation conduit 14 leading from the exhaust manifold 12 through a water separator 15 and a carbon filter 16. The water separator 15 removes moisture from the exhaust gases to be drawn back from the exhaust manifold so as not to cool down the engine, the moisture content thus removed being coupled to the exhaust manifold 12 through a moisture passage 15a. The carbon filter 16, on the other hand, removes carbon in the exhaust gases to protect the engine from contamination. The conduit 14 has provided therein an orifice 14a to regulate the flow of exhaust gases passing therethrough. The exhaust gas drawn into the conduit 14 is passed over to the engine through a flow control valve 17 and exhaust recirculation nozzle 18 leading from the valve chamber and opening into the intake manifold 11. The flow control valve 17 has a valve element 19 which is actuated by a solenoid device consisting of a solenoid coil 20 and moving core 21 which is integral with the valve element 19. The valve element 19 is normally kept seated so as to block the communication between the conduit 14 and nozzle 18. The solenoid coil 20 is connected with a power source 22 through a vacuum switch 23 and speed switch 24 by a line 25. Designated by numeral 26 is an ignition switch which may be interposed between the power source 22 and speed switch 24 or elsewhere, if preferred.

The vacuum switch 23 is operated by a diaphragm device 27 which is responsive to the intake manifold vacuum. The diaphragm device 27 has an atmospheric chamber 28 vented to the open air through a port 29 and a vacuum chamber 30 communicating with the intake manifold 11 through a vacuum conduit 31. The vacuum chamber 30 is hermetically sealed off from the atmospheric chamber 28 by a diaphragm member 32 which is rigidly connected to the vacuum switch 23 by a connecting rod 33 extending through the atmospheric chamber 28. A compression spring 34 is secured to the diaphragm member 32 in the vacuum chamber 30 so that the diaphragm member 32 and accordingly the connecting rod 33 are urged to a position in which the vacuum switch 23 is closed. The compression of the spring 34 is determined in such a manner as to overcome intake manifold vacuum forces lower than a predetermined limit. Thus, the vacuum switch 23 is normally held in a closed position but, as soon as the vacuum in the intake manifold exceeds the predetermined limit and overcomes the compression force of the spring 34, the switch 23 is then brought into open position.

The speed switch 24, on the other hand, is constituted, for instance, as a normally open relay switch which is connected to and actuated by a speed detector 35. The speed detector 35 is arranged to detect the revolution speed of the engine 10 or the driving speed of the vehicle as the case may be and to deliver a voltage corresponding to the speed detected thereby. The relay switch 24 is closed when the voltage delivered from the speed detector 35 exceeds a predetermined limit.

Thus, the solenoid coil 20 can be energized only when the switches 23 and 24 and the switch 26, if any, are closed con-

currently. With the solenoid coil 20 excited, the moving core 21 is moved to a position in which the valve element 19 is unseated, providing communication between the exhaust recirculation conduit 14 and nozzle 18. The exhaust gases in the exhaust manifold are in this manner recirculated in the engine 10 when the intake manifold vacuum is below a predetermined limit and at the same time the vehicle or engine speed is above a predetermined limit.

Now, according to the invention, a thermostatic switch 36 is interposed in the line 25 connecting the solenoid coil 20 and power source 22, the thermostatic switch being herein illustrated as interposed between the solenoid coil 20 and vacuum switch 23. The thermostatic switch 36 is mounted on an engine thermostat housing 37 which is usually provided to regulate the temperature of the engine-cooling liquid.

A preferred example of the thermostatic switch 36 is shown in FIG. 2.

As shown, the thermostatic switch 36 includes a bimetal member 38 which is mounted on the thermostat housing 37 of the engine, moving contact 39 positioned relative to the bimetal member 38 and actuating member 40 secured to the moving contact 39 and held in abutting engagement with the bimetal member 38. The moving contact 39 cooperates with a stationary contact 41 which is connected to the line 25, and is held in contact with the stationary contact 41 by means of the actuating member 40 when the bimetal member 38 deflects with the engine fully warmed up. When, however, the engine is being driven cold and consequently the bimetal member 38 is in a position releasing the moving contact from the stationary contact 41, thus disconnecting the solenoid coil 20 from the power source 22.

It will now be understood that, although the switches 23 and 24 and the switch 26, if any, may be closed all concurrently during cold driving of the engine, the solenoid coil 20 remains deenergized and the valve element 19 seated with the thermostatic switch 36 open. The engine exhaust gases in the exhaust manifold 12 are thus precluded from being recirculated to the intake manifold until the operating temperature of the engine is reached. As soon as the engine is fully warmed up, recirculation of the exhaust gases will be effected provided the switches 23 and 24 are closed.

A modified form of the air pollution preventive system implementing the invention is illustrated in FIG. 3. This modified system is constructed as a combination exhaust gas recirculation and afterburning system having an exhaust gas recirculation unit 42 and afterburning unit 43 connected and controlled by a thermostatic switch 36a through lines 25a and 25b.

The thermostatic switch 36a is constructed similarly to the switch 36 in that it has a bimetal member 38, moving contact 39 and actuating member 40. Different from the switch 36, the thermostatic switch 36a of the modified system has a pair of stationary contacts 41a and 41b connected with the exhaust gas recirculation unit 42 and afterburning unit 43, respectively. The bimetal member 38, when in its normal cold position, permits the moving contact 39 to rest on the stationary contact 41b and, when deflected from the normal cold position, causes the moving contact 39 to abut against the stationary contact 41a by means of the actuating member 40.

The exhaust recirculation unit 42 is constructed essentially similarly to the counterpart of FIG. 1 and includes an exhaust recirculation conduit 14 and nozzle 18, flow control valve 17 intervening between the conduit 14 and nozzle 18, valve element 19 for blocking the gas communication between the conduit 14 and nozzle 18, and solenoid device having a solenoid coil 20 and moving core 21. Designated by numeral 44 is a carburetor which is supported on the intake manifold 11 through a mounting flange 13 and which has mounted therein a carburetor throttle valve 45. The solenoid coil 20 is connected at one end with the stationary contact 41a and at the other with a suitable control switch 46 which is actuated with any of operating variables such as the intake manifold vacuum, vehicle or engine speed, angular position of the throttle valve, or combination of any of these.

The afterburning unit 43, on the other hand, comprises a reactor 47 connected to the exhaust manifold 12 to burn the unconsumed combustible content in the exhaust gases and an injector 48 opened into the reactor to draw fuel thereinto when actuated. The injector 48 is controlled by the thermostatic switch 36a through the line 25b which is connected to the stationary contact 41b, and acts to introduce fuel into the reactor 47 when the line 25b is energized with the moving contact 39 in abutting engagement with the stationary contact 41b. It is well known to provide air to an afterburner such as reactor 47, and this air may be introduced in any conventional manner.

When, in operation, the engine is driven cold, the bimetal member 38 is held in its normal cold position so that the moving contact 39 is held in contact with the stationary contact 41b as indicated by a solid line. In this condition, the line 25a to the exhaust recirculation unit 42 remains deenergized and as a result the exhaust gases in the exhaust manifold are prevented from being recirculated into the intake manifold, while the line 25b to the afterburning unit 43 is energized and the injector 48 permits fuel to spurt into the reactor 47 to aid in the recombustion of the unburned exhaust gases therein. Emission of noxious hydrocarbons during cold driving of the engine is thus reduced to a minimum. As the engine-cooling liquid is warmed up and the operating temperature of the engine reached, then the bimetal member 38 deflects from the normal cold position so that the moving contact 39 contacts the stationary contact 41a as indicated by a dotted line. The line 25b is disconnected from the power source 22 and instead the line 25a becomes energized. The afterburning unit 43 is deactivated and the exhaust recirculation unit 42 now becomes operative to have the exhaust gases recirculated into the intake manifolds. Thus, the quantity of nitrogen oxides can be reduced throughout varying driving conditions of the engine operating at an elevated temperature.

The thermostatic switch for use with the air pollution preventive system according to the invention may be constructed and arranged in many other ways, an example being shown in FIG. 4.

Referring to FIG. 4, the air pollution preventive system is controlled by means of a mechanically actuated switch 36b in accordance with the angular position of a choke valve 49 which is mounted in the air horn upstream of the throttle valve 45 of the carburetor 44. The switch 36b has a moving contact 39, actuating member 40 and a pair of stationary contacts 41a and 41b connected to the units 42 and 43 through lines 25a and 25b, respectively, similarly to the switch 36a of FIG. 3.

The switch 36b is mechanically operatively linked with the choke valve 49 by a cam 50 which is mounted on and rotatable with the shaft 49a of the choke valve 49. The cam 50 is constructed as a sector cam having a partially protruded lobe portion 50a on its peripheral edge with the remaining peripheral edge portion 50b lowered therefrom. The cam 50 and its protruded portion 50a are configured and positioned in a manner that, when the actuating member 40 is in contact with the remaining portion 50b of the sector cam 50, the moving contact 39 contacts the stationary contact 41b as indicated by a solid line and, when the cam 50 is rotated with the shaft 49a of the choke valve 49 and the protruded portion 50a accordingly hits the actuating member 40, then the moving contact 39 is brought into contact with the stationary contact 41a as indicated by a dotted line.

It will now be appreciated from the foregoing description that, according to one important aspect of the invention, recirculation of exhaust gases as practiced for the purpose of reducing the quantity of nitrogen oxides in the exhaust gases is not effected during cold driving of the engine when the quantity of the nitrogen oxides is practically negligible, whereby the engine can be driven with satisfactory performance quality. According to another important aspect of the invention, the afterburning system, used in combination with the exhaust recirculation system, is kept operative until the operating temperature of the engine is reached, whereby the quantity of hydrocarbons that are usually emitted in a notable quantity when the engine is driven cold can be reduced significantly.

What is claimed is:

1. A vehicular air pollution preventive system adapted to reduce the quantity of air pollutants produced during operation of a motor vehicle, comprising first air pollution preventive means for reducing nitrogen oxides in the engine exhaust of a motor vehicle, said first means including an electrically operated valve means for actuation to permit the flow of said engine exhaust through said first means, and control means responsive to the temperature at which the engine is being driven to keep said valve deactuated when said temperature is below a predetermined level, wherein said control means comprises a bimetal member for fixed mounting on the engine, a moving contact positioned relative to said bimetal member for actuation thereby, a first stationary contact positioned relative to said moving contact for engagement thereby, means for electrically connecting said moving and stationary contacts in series between said electrically operated valve and a potential source, and wherein said bimetal member is arranged to keep said moving contact released from said stationary contact when the temperature of said bimetal member is below a predetermined value, and to bring said moving contact into engagement with the stationary contact when the bimetal member deflects in response to a predetermined amount of heat transferred thereto from the engine.

2. A vehicular air pollution preventive system as set forth in claim 1, further comprising second air pollution preventive means for connection to the engine to reduce hydrocarbons in the engine exhaust, and electrically actuated energizing means for said second pollution preventive means, and wherein said control means further comprises a second stationary contact arranged for engagement by said moving contact alternately

with respect to said first stationary contact, and means connecting said moving and second contacts in series between a potential source and said energizing means, whereby said first pollution preventive means operates only when the engine temperature is above a predetermined temperature, and said second pollution preventive means operates only when said engine temperature is below said predetermined temperature.

3. A vehicular air pollution preventive system adapted to reduce the quantity of air pollutants produced during operation of a motor vehicle having an automatic temperature sensitive choke valve, comprising first air pollution preventive means for reducing nitrogen oxides in the engine exhaust of a motor vehicle, said first means including an electrically operated valve means for actuation to permit the flow of said engine exhaust through said first means, second air pollution preventive means for connection to the engine to reduce hydrocarbons in the engine exhaust, electrically actuated energizing means for said second means, and control means responsive to the temperature at which the engine is being driven to keep said valve deactuated when said temperature is below a predetermined level, wherein said control means comprises cam means for connection to an automatic temperature-sensitive choke valve in the engine, first and second fixed switch contacts connected respectively to said valve means and energizing means, a moving contact for connection to a potential source and positioned relative to said cam means for actuation thereby to engage only said second fixed contact when the temperature of the engine is below a predetermined value, and to engage only said first fixed contact when the choke valve deflects in response to the attainment of a predetermined engine temperature.

* * * * *

35

40

45

50

55

60

65

70

75