

[54] AIRCRAFT

[75] Inventor: Jean McComas, West Babylon, N.Y.

[73] Assignee: Fairchild Industries, Inc., Germantown, Md.

[\*\*] Term: 14 Years

[21] Appl. No.: 245,554

[22] Filed: Mar. 19, 1981

[52] U.S. Cl. .... D12/335

[58] Field of Search ..... D12/335, 338, 343, 344; 244/12.3

[56] References Cited

U.S. PATENT DOCUMENTS

- D. 139,438 11/1944 Hughes et al. .... D12/335
- D. 146,072 12/1946 Bowers ..... D12/342
- D. 160,563 10/1950 Thieblot ..... D12/344

FOREIGN PATENT DOCUMENTS

- 886111 1/1962 United Kingdom ..... 244/12.3

OTHER PUBLICATIONS

American Aviation, 4/28/1968, p. 24, in lower left hand corner.

Interavia, v. 31, 8/76, p. 703, in middle of the page on left side-plan view.

Primary Examiner—Wallace R. Burke

Assistant Examiner—Suzanne N. Gitlin

Attorney, Agent, or Firm—Michael W. York

[57] CLAIM

The ornamental design for an aircraft, substantially as shown and described.

DESCRIPTION

FIG. 1 is a perspective view of an aircraft showing my new design;

FIG. 2 is a front elevational view of said aircraft;

FIG. 3 is an elevational view of one side of said aircraft, the elevational view of the other side being substantially a mirror image thereof;

FIG. 4 is an elevational view of the rear of said aircraft;

FIG. 5 is a top plan view of said aircraft; and

FIG. 6 is a bottom plan view of said aircraft.

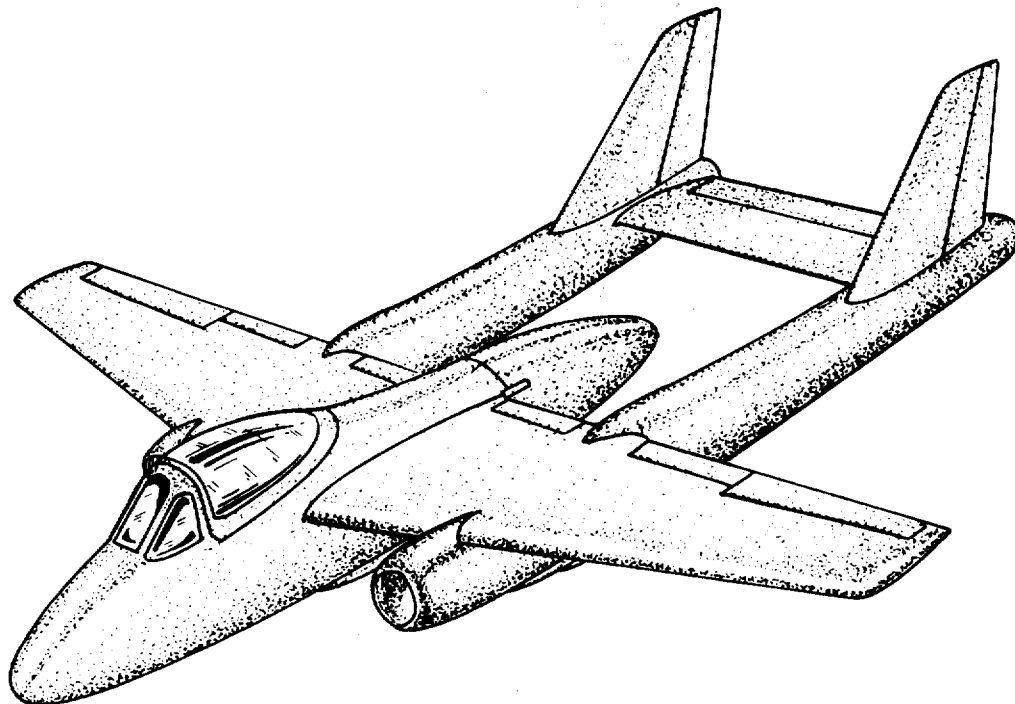

Fig. 1

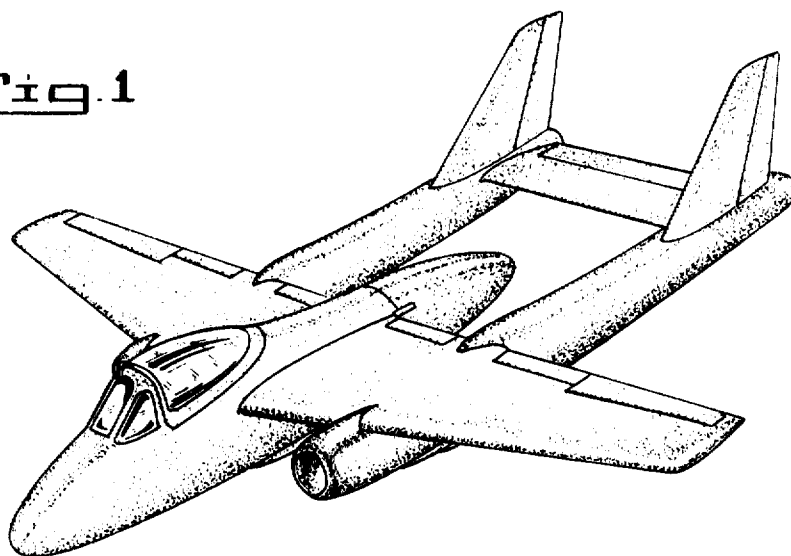

Fig. 2

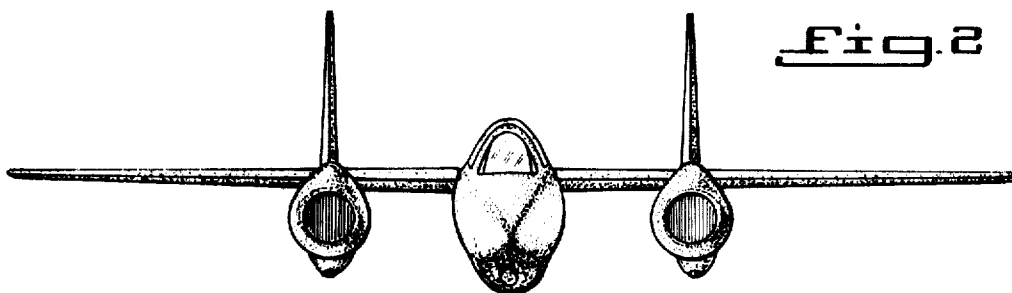

Fig. 3

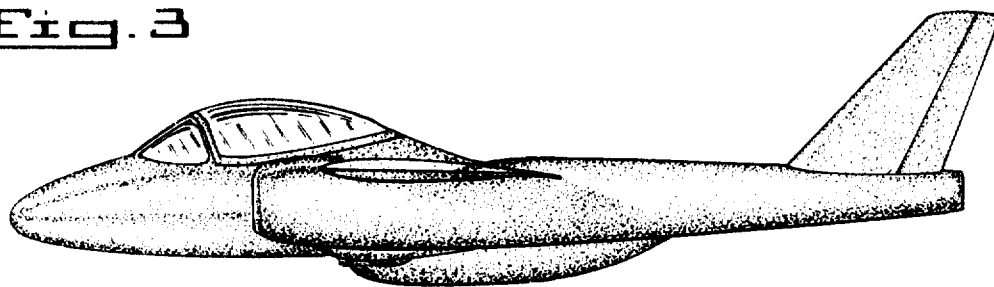
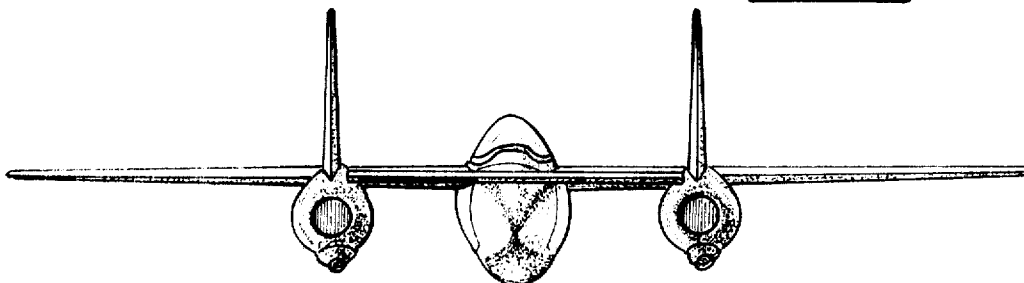

Fig. 4



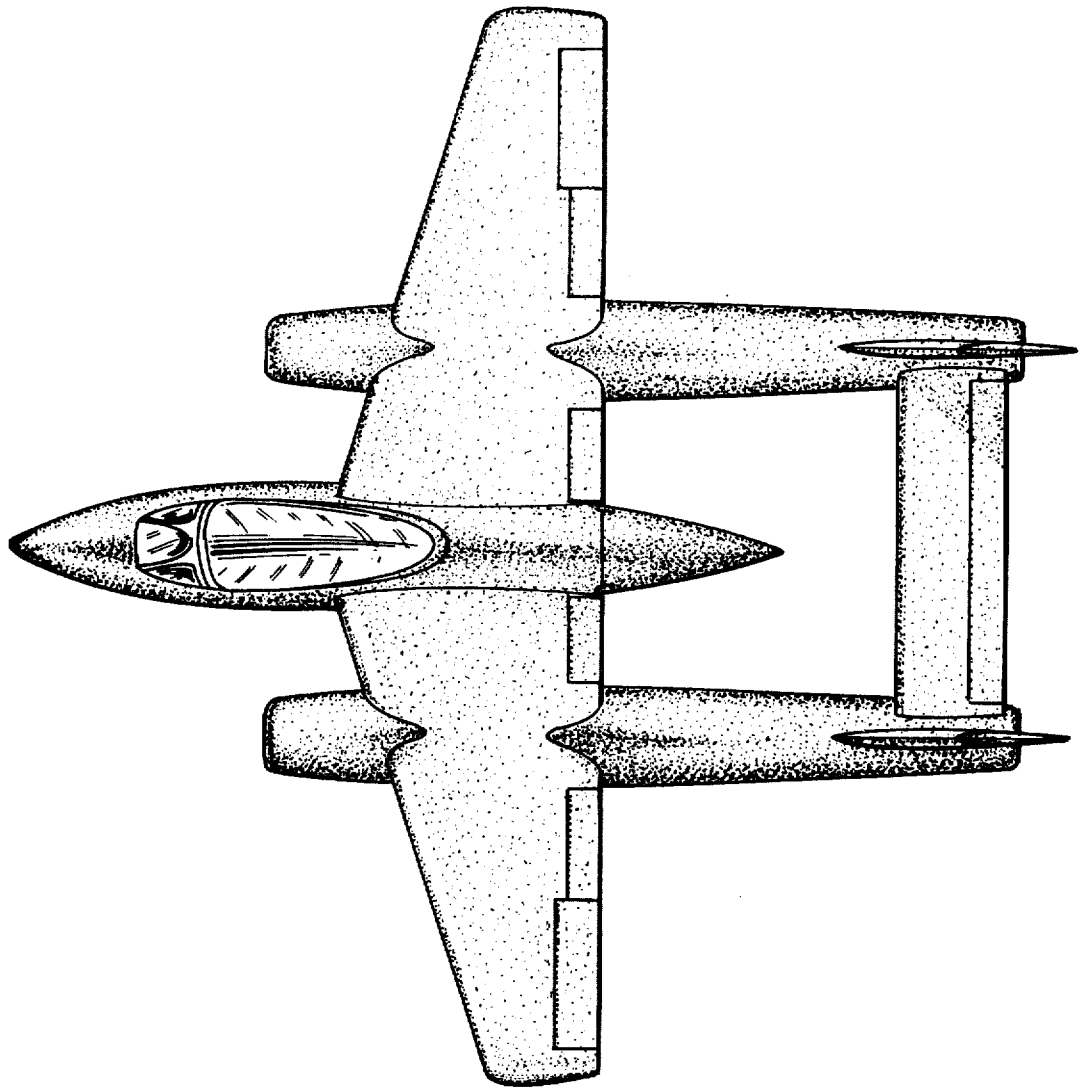

Fig. 5

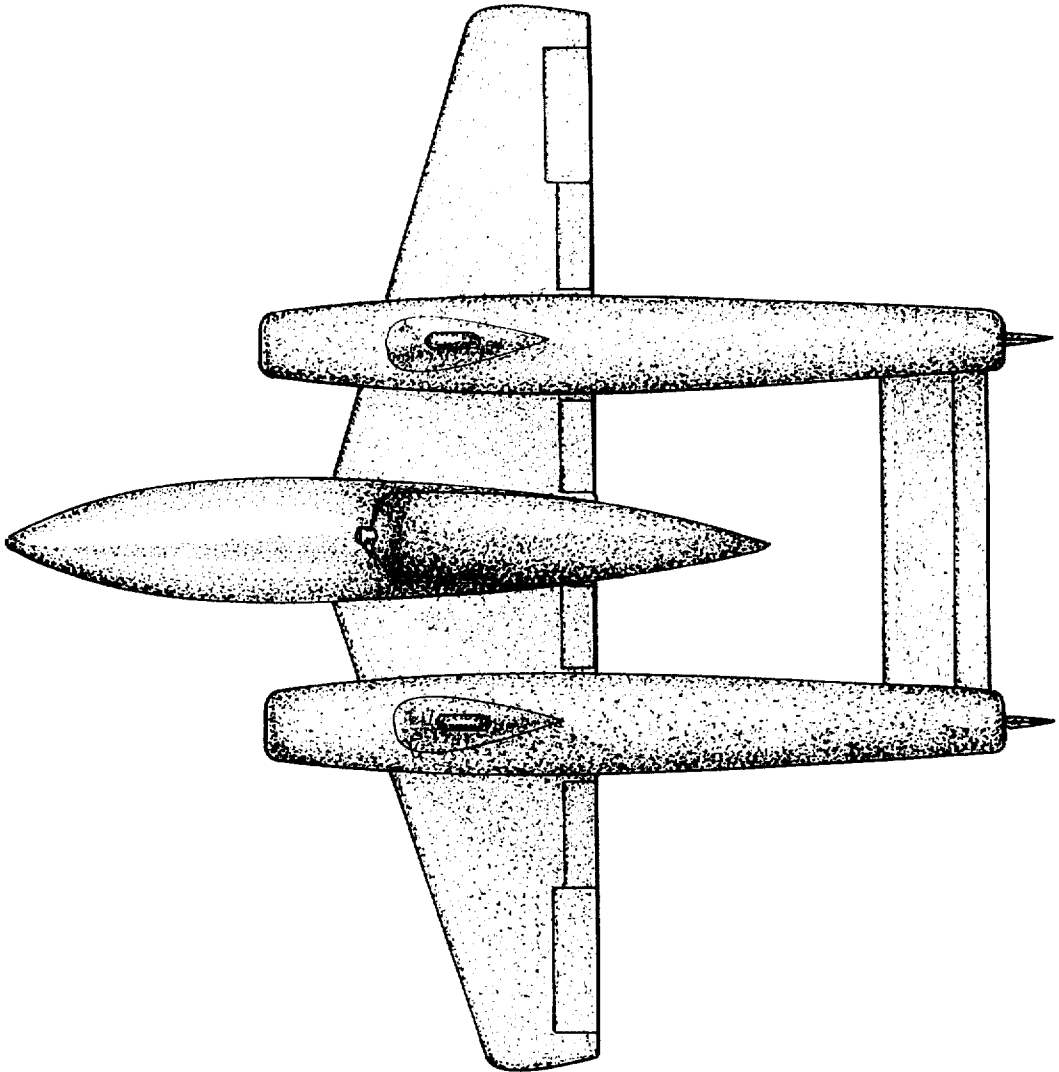

Fig. 6