

[72] Inventor **William M. Holme**
Falls Church, Va.
 [21] Appl. No. **801,685**
 [22] Filed **Feb. 24, 1969**
 [45] Patented **Apr. 6, 1971**
 [73] Assignee **International Business Machines Corporation**
Armonk, N.Y.

[56] **References Cited**

UNITED STATES PATENTS			
3,300,066	1/1967	Henig et al.....	214/11
3,312,949	4/1967	Henig.....	340/172.5
3,320,593	5/1967	Hedrick et al.....	340/172.5
3,397,392	8/1968	Henig et al.....	340/172.5

Primary Examiner—Raulfe B. Zache
Attorneys—Hanifin and Jancin and Melvyn D. Silver

[54] **POSTAL SYSTEM**
3 Claims, 5 Drawing Figs.

[52] U.S. Cl..... **340/172.5,**
214/11R

[51] Int. Cl..... **G06f 15/46**

[50] Field of Search..... **340/172.5;**
235/157, 151.1, 151.11; 214/11

ABSTRACT: A machine for sorting and gathering together articles of like distribution, such as letter mail, which is randomly positioned in a supply source. Each article, being in a respective one of a plurality of categories, is initially sorted by destination or alternatively reclassified to be sorted by dispatch as the machine approaches capacity, so as to provide continuous sorting. Storage means for tallying inventories, and code generating means are included, as well as dynamic program control and physical means for supply source enrichment, tying, and labeling.

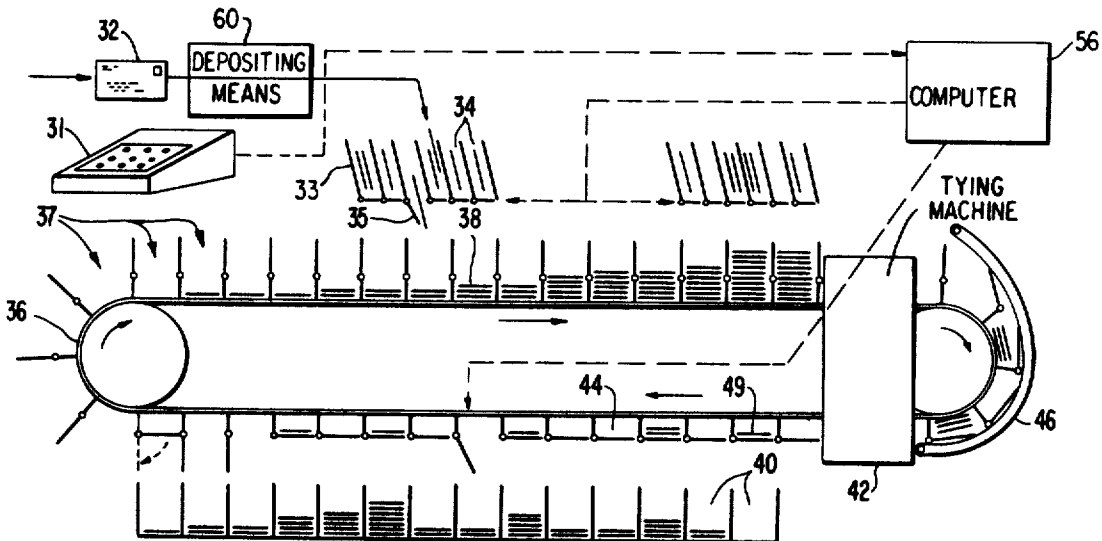

FIG.1
PRIOR ART

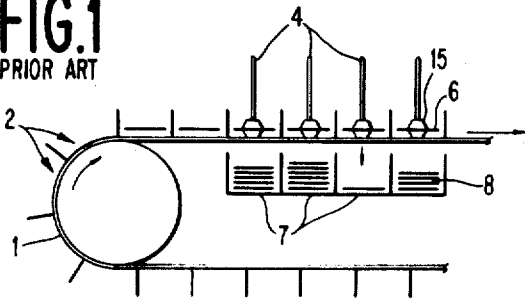

FIG.1A
PRIOR ART

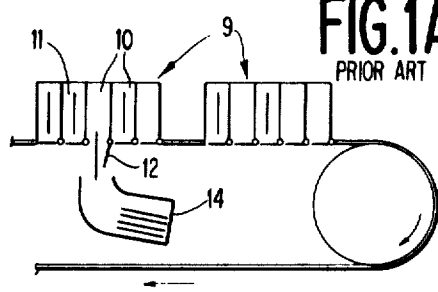

FIG.2
PRIOR ART

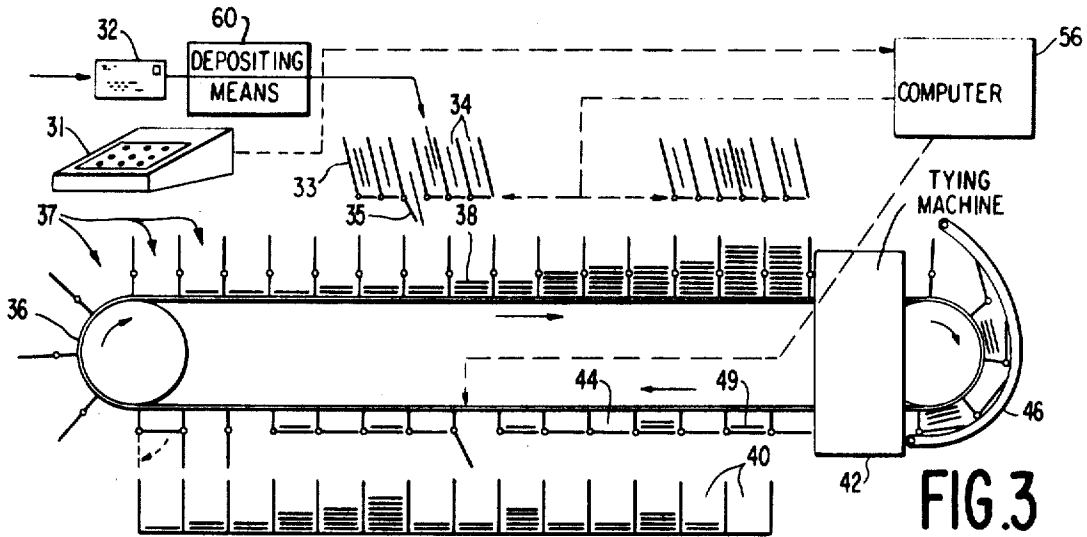
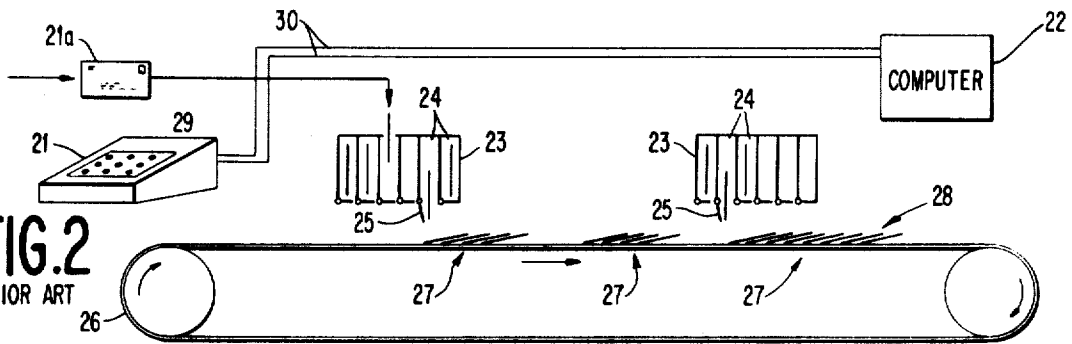

FIG.3

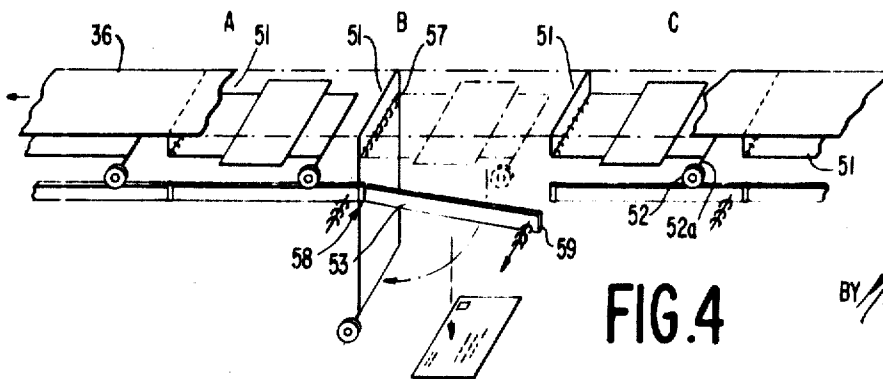

FIG.4

INVENTOR
WILLIAM M. HOLME

BY *Meloy D Silver*

AGENT

POSTAL SYSTEM

FIELD OF THE INVENTION

Means to convey a number of articles or masses of material and deliver a predetermined article or mass to a predetermined point, as a delivery station, according to the will of the operator, there being a plurality of stations, and whereby any article may be delivered to any station at the will of the operator under his control at a control station.

BACKGROUND OF THE INVENTION

Sorting systems become increasingly complex as the random mix and number of articles to be sorted increases, as well as the variety of destinations or categories into which these articles are to be sorted, and the distribution network complexity for handling is increased. To illustrate, mail deposited at a local post office may be in package or letter form. It is initially deposited into a postal box containing similar packages or letters randomly positioned in that box, where each of those articles may ultimately go to any one of some 33,000 post office locations in the United States prior to ultimate delivery to the addressed recipient.

Any sorting system to handle such a wide distribution of articles to be sorted must have a capability of being able to sort individual pieces to form larger handling units going to any individual location, while simultaneously performing this function in a manner so that overloading or jamming of the accumulation unit will not occur. While it is theoretically possible to have a destination slot, bin, or receptacle for each conceivable destination or for each of the 33,000 post offices, into which every article destined for that destination may be deposited, irrespective of size or shape, as a practical matter the incidence or probability of an article deposited at any one location being addressed to certain destinations may be extremely low. This being so, the economics of the system dictate that fewer sorting slots than the maximum number of destinations possible be provided in the physical configuration of the sorting machine, while still maintaining a capacity for separating to every destination articles thereto addressed. Thus, it is an object of this invention to utilize a computer-controlled machine system for separating, identifying and classifying, sorting, gathering, and rerouting of articles, particularly mail, in an integrated man-machine computer-controlled processing system.

A further purpose of this invention is to process any type of material, not necessarily mail, wherein the number of possible distributions in a sorting function is very large relative to the number of sorting separations which may be individually active (or which may receive a plurality of items during a processing period), and which is subject to input media containing unpredictable and/or varying distribution of contents to be sorted, rearranged, and distributed.

Another more specific object of this invention is to provide a system for processing of flat mail, small parcels and rolls, parcels and junk mail, destined for any one of a number of post office locations.

SUMMARY

These and other objects are met by this invention. Briefly, in one embodiment, this invention comprises a data storage and processing means; a primary temporary holding sort means comprising a plurality of presort buffer temporary storage slots; means for generating an address code representing the destination category of each of the articles to be sorted, the address code being stored in the data storage means; depositing means for depositing each article in a selected temporary storage slot, arbitrarily and dynamically selected on the basis of immediate availability, and identifying the contents of that slot by the article's destination category; means for discharging from the temporary storage slots the articles contained therein; and means for keeping a running inventory of articles in each address code held in temporary storage slots and a running count of the extent to which each of the plurality of

sorting slots is occupied, the total number of sorting slots occupied, including the destination category of objects, held in each of those slots, a running inventory and the running count being stored in the data storage means; and means for generating a destination sort code capable of actuating the discharge means to discharge from the plurality of sorting slots all articles of a given destination category, in dependency upon the running inventory and running count, the destination sort code being operative when less than an arbitrarily designated number of the plurality of sorting slots is occupied; and means for generating an alternate dispatch or sort code also capable of activating the discharge means to discharge from the plurality of sorting slots articles of different categories, in dependency upon the running inventory and the running count, the dispatch sort code being operative when more than an arbitrarily designated number of the plurality of the temporary storage slots is occupied; and a program control and switching means for switching operation between the destination sort code and the dispatch sort code in dependency upon the arbitrarily designated number of the plurality of sorting slots being filled. In this manner, the sorting machine is continually alternating between destination sorting and dispatch sorting as a function of the number of slots occupied at any given time and the amount of mail for varying destinations located within those slots. Further, enrichment means for continually enriching and thus affecting the randomness of the mail in the supply source is also provided.

The invention may best be understood in conjunction with the following drawings and general description.

IN THE DRAWINGS

FIG. 1 is a schematic representation of part of the sorting system of a prior art system. FIG. 1A is an alternate embodiment of the system of FIG. 1.

FIG. 2 is a schematic representation of part of a prior art sorting system, from single letter input to multiletter sorted output.

FIG. 3 is a schematic representation of the sorting system of this invention from single letter to bundled, tied output of stacks of sorted mail.

FIG. 4 represents one embodiment of a conveyor belt assembly for use within the sorting system of FIG. 3.

GENERAL DESCRIPTION

Before describing the system of this invention, it is necessary to thoroughly understand prior art sorting systems that have attempted to solve the above problems. One of these is known as the "extended reach" or "conveyorized" method of sorting.

Referring to FIG. 1, this sorting machine essentially consists of a conveyor 1, separated into a series of compartments 2; a fixed proximate number of receptacles 7, and a number of mechanisms 4 along the conveyor length, associated with each receptacle 2, the mechanisms incorporating a plunger, arm, or other mechanical device 15, capable of pushing or otherwise rejecting mail 6, or other items, into fixed, adjacent accumulating receptacles 7 so as to form a stack 8 therein. The essential feature of this system is that it transports items, such as the mail 6, to a preestablished fixed distribution point, where it mechanically ejects and/or releases items into an accumulation receptacle 7 for removal and further routing. The memory and control system to operate such a system is described in concurrence with a later prior art system discussed, the "sweep sort" system.

A widely used alternate of the extended reach system is illustrated in FIG. 1A, wherein the conveyor consists essentially of a number of receptacle boxes 9, each compartment 10 of which is capable of holding one unit 11 to be sorted.

The bottom of each compartment is designed with a trap door 12 such that its contents may be released, by command of appropriate control devices, to an appropriate proximate fixed accumulating receptacle 14 for further disposition.

This method is sometimes referred to as extended reach sorting, since it mechanically makes it possible to make more separations than are manually feasible within the physical limitations of human arm reach.

"Modified extended reach systems" are systems which accomplish more separations than are possible in one pass through the machine, by making a primary separation to major categories on the first sort, then, clearing all accumulation receptacles, and resorting within one presorted group, through the same or an equivalent machine to a secondary classification. Thus, for instance, up to 10,000 separations may be made by two sorting separations through a 100-pocket separation machine, employing some means of identifying the material to be sorted, so that it may be automatically processed in the second, or any other subsequent operation.

In one concept variation, material to be sorted may be identified in the first separation by machine imprinting, labeling, or machine readable encoding at an induction station, so that it may be machine read and processed in the subsequent processing. In another variation of this concept, the material to be sorted may be containerized, item identification for sorting purposes encoded upon such containers, containers sorted through the first machine, and then distributed to a second similar machine for further mechanical sorting. The transportation from first to second machine may be in trays, blocks, or groups of items, or it may be done on a subsidiary conveyor system for continuous flow from output receptacle of the first machine to the input station of the second. In either case, this modified system utilizes the same original extended reach type of machine concept as above (fixed output pockets, moving distributing conveyor), adding to it a method of identifying the material sorted so that it may be subsequently reprocessed for further distribution, without additional manual handling of individual originating units.

SWEEP SORT SYSTEM

The prior art sweep sort system offers several theoretical advantages over the extended reach system. Referring to FIG. 2, the system consists essentially of individual induction stations 21, an online computer control system 22, holding receptacles 23, and a conveyor system 26. The holding receptacles 23 are fixed in position over or otherwise proximate to the conveyor 26, and are divided into individual separate compartments 24, each of which incorporates a trapdoor 25, capable of being quickly and remotely opened upon command from computer 22 to a discharge activating means, not shown. The conveyor system 26 is discretely zoned longitudinally along its system, so that each designated section 27 may accumulate material, as indicated at 28. The position of each section 27 on the conveyor, relative to the fixed receptacle 24 along the system, is known at all times by a computer register system which dynamically advances the position of the conveyor belt in its register, as it moves. The clock in the computer which controls this advancement is in turn set synchronized to the conveyor itself, by suitable, electronic, mechanical, or photoelectric pulse triggering devices, well known in the art.

In operation, an operator at induction station 21 reads the address of a piece of mail 21a presented, and keys a memorized sort disposition code for this address into the keyboard 29. This information is transmitted to the computer system 22 via a direct wire or radio link. The computer 22 refers to its memory to determine which compartment of the holding receptacle 23 is unoccupied, assigns the sort disposition code of the item being sorted to its data storage record for that individual receptacle, and issues a command to a mechanical transport system (not shown) to deposit the mail into that particular receptacle.

In this way, mail is classified, presorted and moved into open available fixed receptacles, under control of the computer which determines this routing, and retains in memory the desired ultimate disposition of every unit to be sorted. This

function is repeated for any desired number of induction stations along the length of the conveyor 26, as required by rate and volume requirements of the system.

Concurrently, the computer accumulates and reviews, in a separate assigned memory storage within the computer, the number of pieces of mail for each different sort category deposited in the storage receptacles, throughout the entire system, as well as their locations. Whenever enough pieces of mail have accumulated throughout the system to make a bundle large enough to tie, the computer dynamically assigns a moving belt section 27 to that destination and commences a routine which compares the address of that belt section with the address of mail in each induction receptacle, as the conveyor belt moves under it.

The location of any such dynamically assigned conveyor section, moving along the conveyor under the induction storage receptacles 24 is known relative to the individual holding receptacles 24, on a real time basis, by the computer system, which advances conveyor section 27 assignments through its registers in synchronization with the physical movement of the conveyor 26. The computer clock is controlled by signals from the conveyor as it moves.

As an assigned section 27 on the conveyor 26 moves under an induction storage receptacle compartment 24, which holds a piece of mail for section 27's now-assigned destination, the computer transmits a control signal to a solenoid mechanism, for example, which releases trapdoor 25 for that compartment. This permits the contents of that compartment 24 to fall down into the advancing conveyor section 27. As conveyor 26 advances under all of the induction storage units, it thus accumulates and groups mail for specific destinations on its separately assigned belt sections for discharge and disposition in sorted categories at the end of the conveyor system.

Concurrently, as the induction holding receptacles 24 release their contents, the computer clears its storage of any assignment of mail to the same, closes and resets the trapdoor, and thereby makes that receptacle available for assignment to, and use by, another piece of mail.

A feature of this system is that any given induction station receptacle 24 may be assigned to and used by only one piece of mail at a time; conveyORIZED sections 27 are assigned to only one destination at a time, but hold multiple pieces of mail. The assignments of destination addresses to both induction receptacles 24 and conveyor sections 27, are dynamic, being reassigned on a real time, online basis by the computer system. The input compartments are fixed, the output belt sections are moving.

This is exactly opposite to the extended reach sorter system, wherein the input receptacles are conveyORIZED and moving; and output compartments are fixed, both physically and as to destination of contents.

The purpose of this sweep sort system is to provide a means of handling a larger number of output distributions than is possible with a fixed pocket extended reach type of sorter, and to permit complete processing and distribution of the mail without multiple handlings.

Each of the three general systems outlined above contains intrinsic shortcomings, for processing and distribution of mail.

A. The extended reach type of sorter is practically limited in number of separations it can make, economically and physically.

1. Beyond a certain number of separations, the utilization of pockets for less active destinations becomes so light, that it is not economical to make machine provision for such sorts.

2. Physical size also becomes a limitation where too many separations are attempted, relative to the throughput capability of the machine.

3. Because of limitation 1, this type of sorting requires multiple handlings in order to obtain the required number of separations. For example, current post office machines accomplish from 150—300 separations in each pass; whereas 3—4,000 distinct post office tie-

- out separations (out of a total of 33,000 different post offices) is not uncommon for a major postal processing center.
4. No provision is made for clearing the output of the machine from its sorting pockets. The system thus requires manual support at the output end, and processing is not fully mechanized.
 5. Because of the uneven and extreme activity volumes of different post offices, the fixed output pocket type of sorter tends to fill up its pockets for very active destinations extremely fast. This creates jamming, and/or severe problems in clearing the machine; or requires manpower in excess of the work content that orderly removal would otherwise indicate.
- B. The modified extended reach systems attempt to overcome the shortcomings of A, by using smaller (less separation) machines, adding a means of encoding the mail (or a unit mail container) for subsequent handling. By using machines with less separations, the machine utilization per pocket is more efficient, which permits mechanized sweeping and removal means. By employing a system for encoding and machine reading of the mail, for subsequent handlings, the added cost of manually reading and keying the mail for subsequent handlings, after the first, may be largely mechanized, at optimum machine rates, reducing the disadvantages of multiple handlings, as appear in the basic extended reach systems. Nevertheless, these configurations still retain, in reduced degree, the basic disadvantages of any extended reach system. The basic disadvantages are as follows:
1. The system essentially addresses the input and sorting problem, but not the one of disposing of the mail after it has been sorted.
 2. The reduced cost of lesser pocket machines is offset by added cost of sweeping mechanisms to clear and stack machine output, where high-speed automatic machines are desired. The cost of such machines appears to increase in throughput rate.
 3. It does require multiple handlings. As contrasted to manual sorting, which requires 3+ handlings per piece on outgoing separation, this system requires almost as many average handlings per piece (machine or manual).
 4. In addition to the added machine cost, this system necessarily requires a costly system to either imprint and machine read the mail, or handle and process special containers.
- C. Computer simulation studies of the sweep sorting type of system have shown this system not to be feasible, as was proposed. Specifically, those studies indicated that because there are many very low volume mail destinations, the input holding receptacle units tended to fill up all storage receptacles, faster than accumulation and release of mail for specific destinations would clear the machine. That is, in a multiple operator input system, the number of pieces for a given low volume destination, as processed into the entire system by a number of different operators within any short given period of time, do not build up fast enough for the system to release them, before all holding receptacle compartments are filled up at some input stations.
- Conversely, on the very high activity level destinations, a number of input receptacle compartments for a few of the very highest volume destinations tend to fill up faster than they are emptied, even though the dynamic sweeping system constantly reassigns conveyor sweeping to those destinations.
- Thus, it was found that a 20-compartment input receptacle system tended to jam itself out of operation in 20—30 minutes; 50-compartment receptacle systems in an hour to an hour and a half; etc. The analysis ultimately concluded that the number of input holding compartments necessary to insure unjammed, continuous operation of the system was economically unfeasible.

THE INVENTION

The machine of this invention is designed to address the following situation. Quantities of mail on a continuing basis are delivered to a local post office from various pickup stations. This mail is introduced into a series of bins from which it will be introduced into the machine to be described. Bundled mail leaves any particular post office only at certain times and along certain routes, inherent in the function of that post office. For example, a post office may ship mail by truck 10 times daily to 10 separate locations along 10 separate routes; it may ship mail by air four times daily along four separate routes; it may ship mail by train 12 times daily along four different routes.

It is desired that mail be sorted in such a manner that whatever mail has been sorted to a given point at a given time be removed from the rest of the mail being sorted or yet to be sorted so that it may be shipped via the train, air, or motor route on schedule. Thus, the mail must be kept in motion and moving toward its ultimate destination with the least amount of delay within the post office. The route that the air, motor, or rail carrier will take is the dispatch along which it runs. Those locations or destinations along which the carrier will stop or may discharge mail are destinations along the dispatch. It is always desired to keep the mail moving whether it be to a destination or along a dispatch so that it may ultimately reach a destination in the least amount of time. While these terms will be described in greater detail later in conjunction with the operation of the machine, it should be kept in mind that this machine is designed as a real time system. The computer, which is a basic part of the machine to be described, will be continually checking a real time clock against the departure schedules of the motor, air, or rail carrier, as well as the particular route of the carrier against the articles being processed through the machine at any one time.

Present mail sorting, which lacks the computerized mechanization, as disclosed herein, separates mail on a geographical or numerical basis. That is, mail which is not sorted direct to a post office destination, is sorted to a secondary "scheme," which could be a state, for instance. The invention disclosed herein is capable of either geographical or dispatch sorting for secondary separation.

This system is hermaphroditic: it combines basic unlike elements of the extended reach and sweep sorting type of systems, in one unitized continuous flow unit, so as to overcome the limitations and shortcomings of either of the other systems, including the modified extended reach method.

Essentially, the system consists of static input modules, similar to the fixed receptacle compartments of the sweep sorting system, with the exception that these compartments are so designed that they may hold a small number of pieces of mail—up to 10 for example—instead of just one piece only.

The output conveyor is segmented for gathering of discrete categories of mail along its length, as in the previous sweep sort machine, but with the additional feature that the belt is compartmented so that mail may be retained on the conveyor, at the end of the belt, carried over, around, down, and back under the conveyor on its return pass, and then released and be directly sorted to fixed position accumulation pockets underneath.

The machine consists of a plurality of operator input stations, configured so as to collect, collate, and gather together items having a like distribution from discrete temporary storage slots at the same or different input stations into a common category bundle, and transport them out of the system for disposition. FIG. 3 illustrates this machine, having, for clarity, but a single input station illustrated. An operator reads mail 32 at station 31, presented by a machine system not shown, but well known in the art.

Each station, such as 31, comprises a first generating means for generating an address code representing the destination category of each article, here a piece of mail. An address code may be, for example, the zip code representing the post office destination for that item; or it may be an alpha-numeric code

obtained by extraction from the full address. Of course, in lieu of the letter, for example, being read by an operator, it may also be read by a magnetic or optical sensing means if each letter has been previously magnetically or optically coded, or by an optical character reader or other such nonmanual reading means.

Thus in the system shown, an operator at a station, such as 31, reads the address of the letter and by depressing appropriate keys on the console of the unit before him, converts the address to an address code.

The address code, once keyed, is transmitted to computer 56. Computer 56 comprises a data storage means, capable of storing each address code along with the address code for each post office. The computer memory includes, as a directory table, information as to other major processing centers through which a destination post office may be further processed, and the dispatches on which it may be routed.

As in the sweep sort machine, an unassigned open slot 34 in primary temporary holding sort means 33 is assigned to each address code, primary temporary holding sort means 33 comprising a plurality of sorting slots 34. The mail is directed and moved into that sorting slot 34 upon command by the computer 56 to a depositing means 60 for depositing each letter according to the letter's address code in a respective one of the slots 34 located at an arbitrarily selected location. The address code identification of the sorting slot is retained in computer memory with the exception that if the address code of that sorting slot has not already been filled with mail beyond its limited capacity, the next envelope having that address code will be moved into that sorting slot, rather than into a new one.

The computer, however, does have means for keeping a first running inventory of each address code and a first running count of the extent to which the plurality of sorting slots is occupied, this first running count and first running inventory being stored in the storage means of the computer. Thus, at any given moment, the computer "knows" the address code assigned to each sorting slot, the number of letters in each slot, and the number of slots occupied, or conversely, those available to be filled, and their locations, and the total amount of mail in the entire system for each address code.

Similar to the sweep sorter concept, moving compartments 37 on conveyor 36 are dynamically assigned to specific destinations by the computer from its inventory of mail in the sorting slots, and its release program, discussed later.

As the moving compartments 37 move under fixed sorting slots 34 in the different input stations, having a corresponding address code, the address code match in the computer program causes solenoids, for example, to be actuated so that the appropriate trapdoors 35 are opened, and mail is accumulated in stacks 38 for transport out of the system.

The solenoid-trapdoor combination would comprise, as an example, a first discharge means for discharging from the sorting slots the letters contained therein. Other release means are, of course, available.

To this point, to discharge letters from these sorting slots into the conveyor compartments is required a second generating means, in the computer, for generating a destination sort code, the destination sort code capable of activating the first discharge means to discharge from the plurality of sorting slots all letters of a given address in dependency upon the first running inventory and the first running count, the destination sort code being operative when less than an arbitrarily designated number of the plurality of sorting slots is occupied.

Thus, up to this point, the machine operation may be described in summary.

Mail is automatically brought to an initial reading station. An operator at this station reads the address on the mail. The operator depresses on the keyboard before him the address code representing the post office destination of that piece of mail prior to actual delivery by a mailman to home or office. While zip code is one means of keying this mail, other means will known in the art are equally applicable. For the purposes

of this illustration, however, the operator will key the zip code for that piece of mail. By his action, the operator has now given this piece of mail, which is in a given destination category, i.e., mail destined for a given post office, an address code.

This address code is transmitted to a computer. The computer has storage means for retaining in its memory that that address code has been transmitted to it, and will record the same in its inventory record. The computer, in turn, instructs a depositing means to take that piece of mail and deposit it into one of a plurality of sorting slots in the primary temporary holding sort means.

Each slot may hold an arbitrarily designated number of letters, for example, 10 letters per slot. Each piece of mail having the same address code is deposited in the same slot until such slot is full. At that time, additional pieces of mail having the same address code are deposited in the next available slot. The computer keeps track of the number of pieces of mail of each address code in each slot, the location of those slots, and the number of slots filled or conversely, the number of slots yet to be filled and thus available for additional category code sorting.

Each sorting slot has a first discharge means that can be activated upon command from the computer to discharge, for example, by gravity, the mail contained in the sorting slot. In this illustration, a conveyor belt having compartments upon it is operative and running beneath the primary sort means. A second generating means, such as a computer program, is operative to generate a destination sort code within the computer. The destination sort code is capable of activating the first discharge means to discharge from the slots those letters for a given destination category in dependency upon the running inventory and the running count. The address code is operative when less than a given number of primary sorting slots are occupied.

The destination sort code will operate in the following manner, for example. Assume that it is desired that each bundle of mail or each sort for a given destination category contain no less than a given number of letters, for example, 50 letters. If each sorting slot can hold 10 letters, this would require that no discharge take place from these sorting slots until five of such slots or the equivalent, were full throughout the system. Thus the computer, keeping track of the location of each category code within a slot and the number of slots occupied, would at a given point (50 letters in the sorting slots) clear those slots having the same address code of the mail contained therein. This is done by choosing an empty compartment on the moving conveyor and as that compartment passes beneath the sorting slots, serially triggering the sorting slot release means upon command from the destination sort code, thus releasing the mail of a given address code into that chosen compartment on the conveyor. Thus in the illustration given, a number of different slots at different locations would serially discharge mail of the same given address code into the same conveyor compartment as the compartment moves beneath the slots.

The empty slots are now available, of course, for mail of other address codes. Thus, upon command from the computer via the destination sort code, the primary temporary holding sorting means is continually emptied as mail is sorted, and continually refilled by the depositing means via the initial system described. Thus, a real time dynamic system is in operation.

The sorted mail in the conveyor compartments is conveyed directly into and through an online automatic tying machine 42 which ties and labels the mail under computer control. The conveyor unit performs two other functions as will be described subsequently.

Not all mail is processed in this fashion.

As mail temporarily accumulates in the sorting slots 34, and the number of available unused sorting slots approaches a critical minimum number, the computer will determine, by preset programmed rules, whether or not to release less active address destinations or address codes, by making smaller bun-

dles for tie-out, or to activate an alternate routine. In any event, when an arbitrarily designated number of the plurality of sorting slots is occupied, an alternate routine takes over.

Initially, the computer program has a constant number which is the number of pieces of mail desired to be accumulated for a destination, before mail for that destination is to be released, swept, and tied out into a bundle.

A second program polls the contents of the different temporary storage holding receptacle stations. Whenever the contents of any station approach saturation, such that it will shortly be unable to receive more mail, the program initiates a modification routine on the number of pieces of mail required to make a tie-out, reducing the same in fixed increments, down to 10 letters per bundle, for example, until the impending bottleneck is released.

As soon as the impending saturation relieved, the program reverts to the original constant number of pieces for a bundle. If the program iterates and advances down to 10-letter bundles, without correcting the situation, the alternative routine is called out.

Assuming that the latter has become necessary to clear the system, the computer then searches its stored inventory balance information for the addresses for all pieces of mail in storage for which there is only one piece of mail in the temporary storage holding compartments. For each of these, the address is looked up against a table, to determine the next dispatch on which each of those pieces of mail is going out (or to which postal processing center the mail should be sent for further separation, in an alternative system). Stored data, as to address disposition of those pieces of mail, in their respective individual temporary storage holding compartments, is then updated in memory, to correspond to the new disposition address, based upon a dispatch or secondary sort scheme category.

Only those pieces of mail which have an address inventory balance of one are initially so recategorized in the first iteration, and processed as described below.

The disposition is determined by a dispatch sort code. This requires a third generating means, in the computer, for generating a dispatch sort code, the dispatch sort code also capable, as with the destination sort code, of activating the first discharge means to discharge from the plurality of sorting slots articles of different destination categories, in dependency on the first running inventory and the first running count, the dispatch sort code being operative when more than the arbitrarily designated number of the plurality of sorting slots is occupied. Thus, an initial and primary difference is that whereas the destination sort code will cause release of all articles of a given destination category, the dispatch sort code discharges articles of different destination categories but the same dispatch category from the sorting slots. The dispatch is sorted in the following manner.

Where there are an insufficient number of articles to form a tie-out or bundle for a given destination, and the machine temporary holding sorting slots become overly occupied, i.e., tendency toward full utilization and thus jamming, the dispatch sort code will cause release into a single moving compartment on the conveyor of the contents of those sorting slots having addresses which contain the least number of articles therein, with a common factor being that while address codes of each set of articles from each sorting slot is different for each release to a compartment on the sweeping conveyor, all will ultimately be delivered to their destinations along the same route or dispatch. For example, if a railroad train were to deliver mail from New York City to Poughkeepsie, N.Y., passing along its route Yonkers, Dobbs Ferry, Hastings, Tarrytown, Ossining, Peekskill, Cold Spring, Beacon, and finally terminating at Poughkeepsie, mail destined for any of those locations to go onto that given train would constitute the dispatch for such mail. Thus, many destinations lie along a given dispatch. The dispatch sort code would thus cause clearing of the least filled slots lying along this dispatch. In contradistinction, a destination sort code release would release

only mail going to one of those given locations, i.e., Tarrytown or Ossining, etc.

The code then updates and sets the computer registers for those sorting slots by a mail processing dispatch number, instead of destination address, and dynamically assigns conveyORIZED compartments 37 to such dispatch number codes, so that mail will now be accumulated in groups along the conveyor by dispatch, rather than by destination address.

The system is so programmed that when it becomes necessary to reassign disposition codes (i.e., from destinations to dispatches), only those pieces of mail having one piece of mail per address, throughout the system, are recorded, released, and swept into dispatch compartments. The computer then reevaluates the storage condition of the temporary storage holding slots. If the approaching saturation condition, which previously caused the reassignment routine to begin has been relieved, the system goes back to releasing, sweeping, and gathering mail for direct address destinations only as it had been, previously. If the impending saturation condition is not relieved by releasing pieces of mail for which there is only one piece of mail per destination, the reassignment routine reiterates and searches inventory for all those pieces of mail for which there are only two pieces per destination, reassigns their address category to dispatch (or some other secondary scheme), and releases for gathering and sweeping in the conveyor compartments, as before. This routine reiterates one additional piece of mail per destination count for reclassification, up to 10 pieces of mail for an address, if necessary, until the approaching saturation utilization of the temporary holding slots condition has been relieved. No more such reclassification of address categories is made than necessary to relieve the filling up of temporary holding slots beyond unsaturated working capacity; the object of this routine being to prevent temporary storage slot saturation, by removing the minimum amount of mail necessary.

Thus, when the number of sorting slots occupied becomes less than the arbitrarily designated number, a first program control and switching means in the computer, switches operation from the dispatch sort code back to the destination sort code for continued operation.

As the compartments 37 which hold reclassified mail for dispatch or secondary separation go through the tying, labeling, and bundle sorter unit 42, the computer program activates an alternative instruction to the unit 42 which causes it to bypass the tying operation, and allows the compartment to pass around, under, and back along the underside of the conveyor.

As such batches of mail return along the underside of the conveyor, they are held onto the conveyor, until they pass a collection station 40 which has been assigned to a specific, fixed dispatch (or secondary separation grouping) by the dispatch sort code via computer command.

At that point in time, determined by the dynamic computer memory, which is advancing data in synchronization with the conveyor and matching the same with correspondingly adjacent collection stations, the computer program releases a command instruction which causes the mail so carried to be dropped into its appropriate dispatch collection station, which may comprise a bin or tray.

Additional means are here present to keep a second running inventory of each address code within each dispatch, the number of articles collected in each collection station, the dispatch code for each collection station and the location of each collection station. All this is stored in the computer data storage means.

The mail is accumulated in collection stations 40 until the time a particular dispatch is to be processed or the number of articles in any given collection station exceeds a predetermined number. This is done as follows.

The computer, keeping track of the number of articles in any given collection station and the address codes therein, finds through a running tally that that collection station contains enough mail along a given dispatch of the same address

code to allow a secondary sort by address code. Thus the computer will activate means for reintroducing mail collected in that collection station into the supply system. This mail then comprises enriched (i.e., a concentration of mail for a limited number of destinations) rather than random distribution of mail for 33,000 different post offices as originally supplied. Additional tie-outs may then be made, by further sorting, if the computer inventory indicates that the distribution of mail within that group warrants the same.

However, this being a real time system, there may be insufficient mail within each destination category to warrant such a sort. As the time schedule programmed within the computer signals that any mail to go along the dispatch, as for example from New York City to Poughkeepsie, must be pouched for delivery to that train by a given hour, it may call out all mail along that dispatch to be reintroduced within the unit, sorted into separate sorting slots, and if these slots still contain insufficient amounts of mail to warrant a destination sort, the machine will then reassign sorting instructions to call out a sort to another postal processing center closer to the destination for such tie-out. In this manner, both mail to a specific end-point destination, and dispatch (or secondary scheme) coded mail can be bundled in sufficient time to meet a carrying means such as the train cited, for prompt deliver. Of course, as is well known in the post office, dispatch mail goes to a sectional center post office where the volume of mail for destinations along the dispatch is greater than at the originating station, whereby this mail is introduced into the original source from that post office, destination coded by another machine similar to that being here described, for ultimate destination delivery. Thus, the mail from one dispatch is reintroduced into the system and reprocessed. Since there are only a limited number of separations on any one dispatch, and this mail has been "enriched" to the extent that it has already been gathered together into a limited number of destinations comprising a dispatch, all mail will be tied out into either a direct destination or a transit post office destination for further processing. There is no further unit handling.

The tying and labeling machine 42 includes within its design the capability of removing all bundles which have been tied and labeled, from the conveyor. This function may thus be performed mechanically, as well as manually.

Tying and labeling instructions are, of course, received from the computer, synchronized with the arrival of the conveyor compartments of the mail to be tied and labeled. This unit, therefore, has the capability of serving as an induction station to a connected bundle sorting machine, not shown.

At this station the mail is either bundled, removed, and sorted into a sack, or the sweeping conveyor system carries it through, around, and underneath the conveyor system so that it may be automatically discharged to fixed pocket collection stations underneath the machine for a second handling.

Just as the sorting slots may become "overutilized" with a tendency toward jamming, the same is true of the collection stations beneath the conveyor. Thus, additional means may be provided for allowing discharge from the collection stations of articles contained therein, and means for generating an enrichment code, the enrichment code capable of activating the discharge means to discharge from the plurality of collection stations all articles of a given dispatch, in dependency upon the second running inventory and the number of collection stations occupied, the enrichment code being operative when an arbitrarily designated number of collection bins is occupied; and means for generating a station clear code, the station clear code capable of activating the second discharge means to discharge from the plurality of collection stations articles of different dispatches, the station clear code being operative when more than an arbitrarily designated number of collection stations is occupied; and second switching means for switching operation between the enrichment code and station clear code in dependency upon the arbitrarily designated number of collection stations being occupied. Thus, the collection bin storage problem is handled in the same manner as the sorting

slots occupation problem is handled in the primary sort means. In normal operation, of course, collection bins are continually being emptied to form enriched mail in the supply source, so that ultimately most mail may leave via a destination code, i.e., by category code.

Many mechanism are possible for the compartmented conveyor which permit it to carry mail around its end, and back along underneath, so as to do direct sorting on its return pass.

One possible means by which this might be accomplished is shown in FIG. 4. Attached to conveyor 36 (cut away to show detail), the compartment separators 51 may be constructed with a spring-loaded hinge 57, so that normally they stand straight out from the conveyor, as in position B, but when constrained by an interfering member, they will fold back to form pockets, as in positions A and C.

In FIG. 4, these pockets incorporate extensions 52a at either or both sides, upon which small wheels or rollers 52 are mounted.

As the compartments pass around the output end of the conveyor at C, fixed rails 46, shown in FIG. 3, engage the extending rollers 52 on the top or outer edge of each compartment to fold back around their spring-loaded, hinged sections 57, in FIG. 4. Thus, any mail still in the compartment is held in place by that portion of the compartment which is folded back and becomes the trailing bottom of an enclosed pocket 44, in FIG. 3, and is shown holding a piece of mail at 49.

As these compartments are moved from right to left underneath the conveyor, that portion of the leading wall 51, FIG. 4, which is articulate, is held in a horizontal position, as a pocket, by the wheels or rollers 52, as they engage and roll over segmented sections of tracks 53, adjacent to the conveyor compartments. The segmented sections of track 53 are mounted in a hinged way at their forward ends 58, so that they can be externally actuated at ends 59 to pull them out and away from the otherwise continuous, segmented track (sections 53), illustrated in position B.

Thus, when it is desired to release mail from the pockets, the computer will actuate a solenoid, not shown, so as to pull the section of track over the desired sort pocket out of engagement with its adjoining section of track at one end (B). When this occurs, there will be no support for the next compartment pocket moving into position; the spring-loaded compartment wall will spring down into a vertical position, and contents of the pocket will be released. Compartments so restored to their original upright position (now upside down), will retain this position throughout the remainder of the conveyor cycle, until reset into pockets by the fixed turn-around track unit 46, at the end of the conveyor, as shown in FIG. 3, which functions as a cam to close the pockets.

It will be seen that this system overcomes the obstacles which prevented the original sweep sort letter sorting machine from being feasible, as found under simulation, in many ways:

1. By permitting the accumulation of more than one piece of mail for one destination in an induction receptacle compartment, it substantially reduces the loss of capacity that occurs when a very high volume run of mail occurs for one destination at one input station.

2. By providing a means to remove, sort, and enrich very low density outgoing mail, using a direct sort feature in addition to the sweep sort concept, the system can be controlled so that it will never fill up and stop. At the same time, it continues to make direct tie-outs of the largest possible number of destinations at all times, optimizing the tie-out scheme on the basis of current mail distribution patterns.

3. The end result of this configuration is a system which will separate and sort the mail in only slightly more than one handling per unit piece; in a larger post office, only 10-20 percent of the outgoing mail may require a second handling. This represents a substantial improvement over any other known mail sorting systems manual or machine.

4. The portion of mail requiring a second handling is so small that the function of machine imprinting and coding may not be required.

13

5. The system is essentially "continuous flow," i.e. accomplishes the original objectives the sweep sorter tried but failed to achieve, and requires substantially less costly mechanical handling devices than the various existent or proposed extended reach machines.

While this system has been described primarily with mail sorting in mind, it is evident that by proper choice of slot sizes, etc., other articles besides mail may be sorted. And while particular means have been described, equivalents are possible, and likely as technology improves.

I claim:

1. A machine for sorting articles by collecting them from randomly positioned locations from at least one of a plurality of supply sources, each article being in a respective one of a plurality of destination categories comprising:

first generating means station for generating an address code representing the address of each of said articles;

a primary sort means comprising a plurality of temporary holding slots;

depositing means for depositing each article in selected respective one of said slots;

first discharge means for discharging from said slots the articles contained therein;

collecting means for collecting and labeling the articles discharged by said first discharge means;

tying means for selectively tying said articles collected by said collecting means;

collection stations for storage of those of said articles not selectively tied by said tying means;

a control computer, said control computer further comprising:

a means for keeping a first running inventory of the number of articles in each address code by slot location and a first running count of the extent to which said plurality of sorting slots is occupied,

a second generating means for generating a destination sort code, said destination sort code capable of activating through said computer, said first discharge means to discharge from said plurality of sorting slots all articles of a given destination category, in response to said means for keeping a first running inventory and said first running count said destination sort code being generated when less than an arbitrarily designated number of said plurality of sorting slots is occupied,

third generating means for generating a dispatch sort

14

code, said dispatch sort code capable of activating through the computer said first discharge means to discharge from said plurality of sorting slots articles of different destination categories, in response to said means for keeping a first running inventory and first running count, said dispatch sort code being generated when more than an arbitrarily designated number of said plurality of sorting slots is occupied,

and first control and switching means responsive to said means for keeping a first running count and said arbitrarily designated number of said plurality of sorting slots filled at a given time,

said control computer operatively connected:

to said first generating means station for receiving the address codes representing the destination of said articles from said first generating means station,

to said depositing means for controlling the deposit of said articles of like address codes in the same ones of said slots,

to said first discharge means to control the release of said first discharge means for discharging said articles from said slots,

to said collection means for controlling said collection means to accept said articles discharged from said slots by said first discharge means,

to said tying means for controlling said tying means to selectively tie said articles in bundles and selectively pass the remainder of said articles into said collection stations,

whereby articles deposited by said depositing means in one of a plurality of temporary holding sorting slots are discharged from said slot by said first discharge means under the control of said control computer and is carried by said collection means to a tying means where predetermined quantities of articles having identical codes are tied and diverted from the sorting machine.

2. The machine of claim 1 wherein said collecting means comprises an endless conveyor having compartments thereon, positioned to travel beneath said slots.

3. The machine of claim 2 wherein each of said compartments comprises:

means for retaining articles contained therein as said conveyor belt traverses an underside path; and

means for discharging from said compartments articles contained therein.

5
10
15
20
25
30
35
40
45
50
55
60
65
70
75