

No. 756,863.

PATENTED APR. 12, 1904.

A. H. LEWIS.
MINE DOOR.

APPLICATION FILED JUNE 20, 1903.

NO MODEL.

3 SHEETS—SHEET 1.

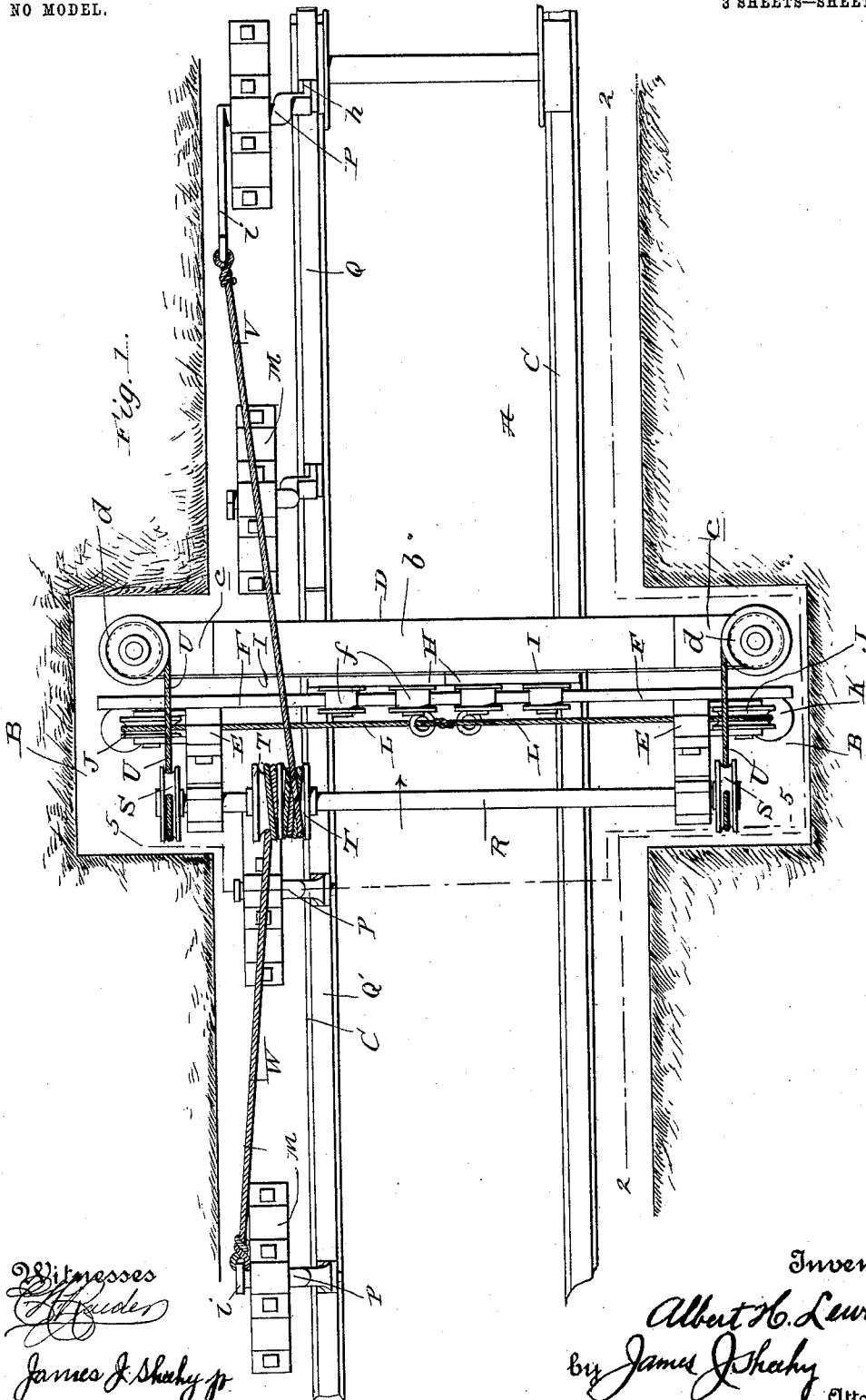

Witnesses
James J. Shady jr.

Inventor
Albert H. Lewis
by *James J. Shady* Attorney

No. 756,863.

PATENTED APR. 12, 1904.

A. H. LEWIS.
MINE DOOR.

APPLICATION FILED JUNE 20, 1903.

NO MODEL.

3 SHEETS—SHEET 2.

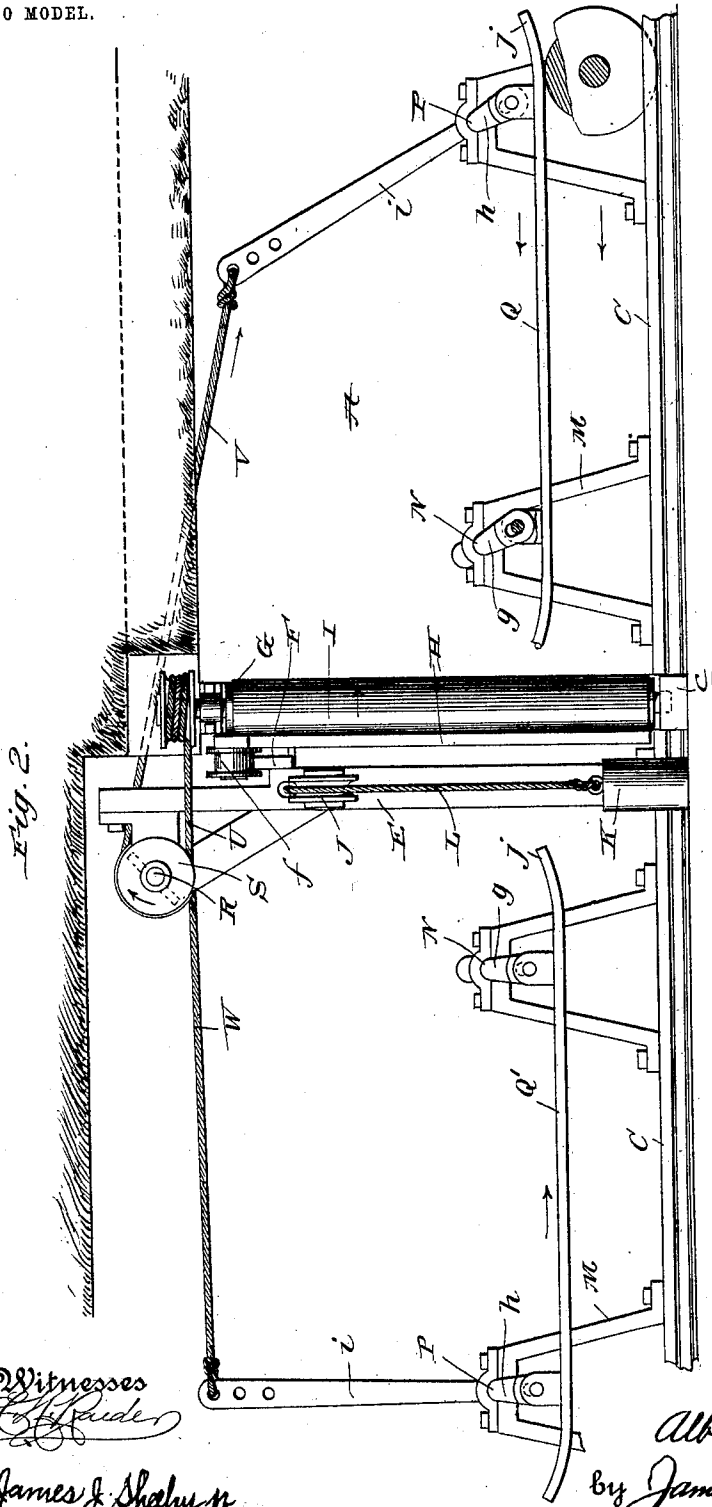

Fig. 2.

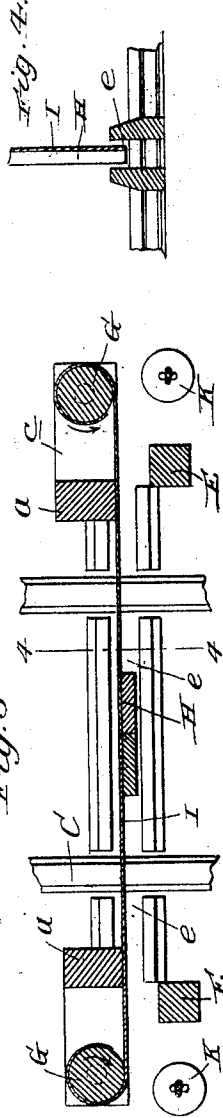

Fig. 3.

Witnesses
Chas. P. ...
James J. Shalby Jr.

Inventor
Albert H. Lewis
by James J. Shalby Attorney

No. 756,863.

PATENTED APR. 12, 1904.

A. H. LEWIS.
MINE DOOR.

APPLICATION FILED JUNE 20, 1903.

NO MODEL.

3 SHEETS—SHEET 3.

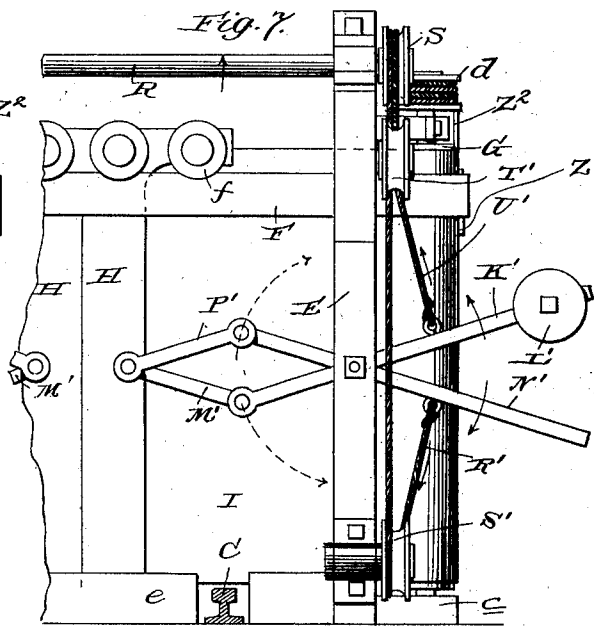
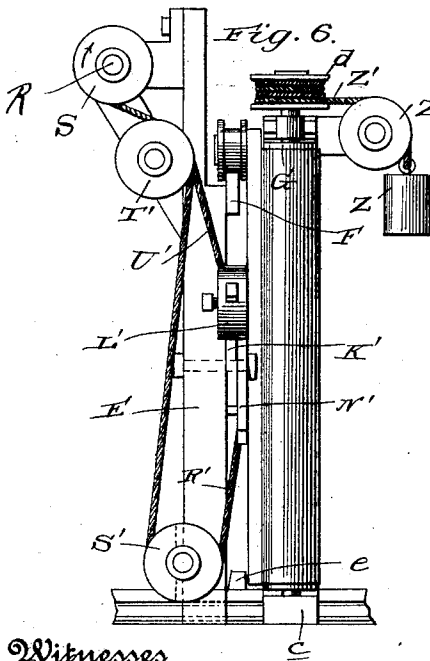
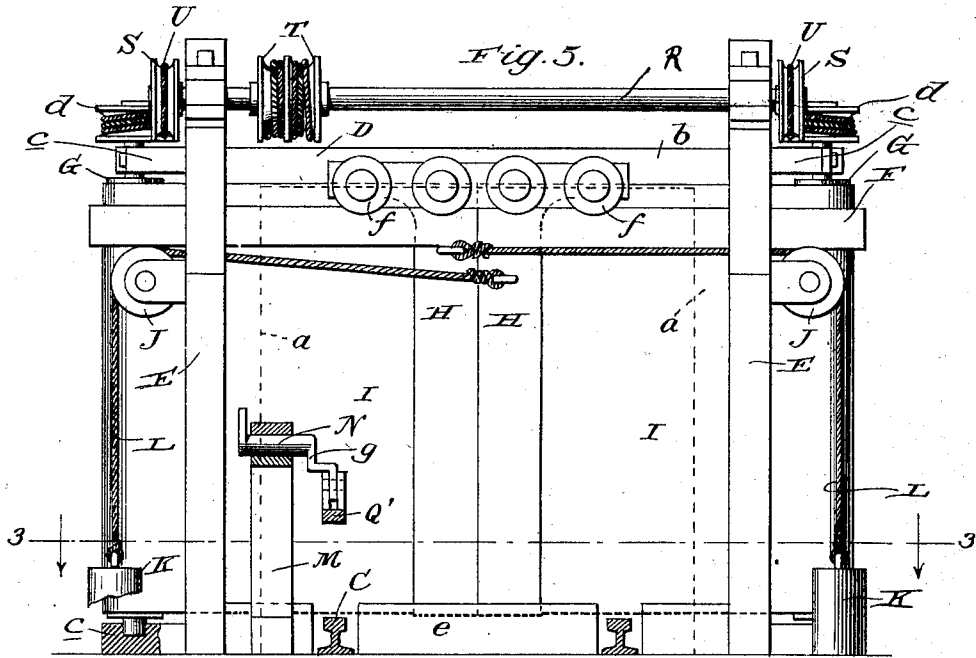

Witnesses
[Signature]
 J. J. Sheehy jr.

Inventor
 Albert H. Lewis
 By James J. Sheehy Attorney

UNITED STATES PATENT OFFICE.

ALBERT H. LEWIS, OF UHRICHSVILLE, OHIO, ASSIGNOR OF THREE-
FOURTHS TO ALBERT G. QUIMBY, JAMES C. SHIELDS, AND ARTHUR
E. SPEAR, OF UHRICHSVILLE, OHIO.

MINE-DOOR.

SPECIFICATION forming part of Letters Patent No. 756,863, dated April 12, 1904.

Application filed June 20, 1903. Serial No. 162,372. (No model.)

To all whom it may concern:

Be it known that I, ALBERT H. LEWIS, a citizen of the United States, residing at Uhrichsville, in the county of Tuscarawas and State of Ohio, have invented new and useful Improvements in Mine-Doors, of which the following is a specification.

My invention relates to doors; and it has for its object to provide a mine-door so arranged and constructed that it entirely disappears when opened and offers no obstruction to cars on a track and means whereby a car approaching the door in either direction is enabled to open and hold the door open until it passes the same.

With the foregoing in mind the invention will be fully understood from the following description and claims when taken in connection with the accompanying drawings, in which—

Figure 1 is a plan view of a construction constituting one embodiment of my invention; Fig. 2, a view, partly in side elevation and partly in section, taken on the broken line 2 2 of Fig. 1; Fig. 3, a detail horizontal section taken in the plane indicated by the broken line 3 3 of Fig. 5; Fig. 4, a detail section taken in the plane of the broken line 4 4 of Fig. 3; Fig. 5, a transverse section taken on the broken line 5 5 of Fig. 1; Fig. 6, a side view of a modified construction hereinafter referred to, and Fig. 7 a detail front elevation of a portion of said construction.

Referring by letter to said drawings, and more particularly to Figs. 1 to 5 thereof, A is the entrance to a mine; B B, pockets mined in the walls at opposite sides of the entrance; C C, track-rails extending through the entrance and designed for the travel of mine-cars; D, a fixed frame comprising uprights *a*, Fig. 3, disposed in the pockets B, and a cross-bar *b*, Fig. 1, arranged on and connected to said uprights and extending across the entrance A; E E, fixed uprights disposed in the pockets B at one side of the frame D; F, an overhead track-rail connected to and supported by the uprights E; G G, vertical drums journaled in brackets *c* at opposite ends of the

frame D and having grooved pulleys *d* at their upper ends; H H, door-sections, preferably of wood, having their lower ends arranged in a transverse guideway *e*, Figs. 3 and 4, and also having antifriction-wheels *f* at their upper ends movable on the overhead rail F; I I, strips of heavy canvas or other suitable flexible material which, in conjunction with the sections H, form my improved door and which are connected at one end to said sections H and at their opposite ends to the vertical drums G; J J, vertically-disposed grooved pulleys mounted on the uprights E adjacent to the upper ends thereof, Fig. 5; K K, weights; and L L cables passed over the pulleys J and connecting the weights K and the door-sections H, each weight being connected with the door-section remote from the same. In virtue of the construction thus far described it will be observed that when the drums G are turned on their axes in the direction indicated by arrows, Fig. 3, the flexible sections I will be wound on the same, the sections H drawn outwardly, and the door opened to permit of the free passage of a mine-car, while when said drums G are released the weights K, raised by the opening of the door, will gravitate, and thereby draw the sections H toward each other and the sections I off the drums and close the door. In order to enable a car approaching the entrance A in either direction to rotate the drums G on their axes and open the door formed by the sections H H and I I, I provide the mechanism best shown in Figs. 1 and 2. This mechanism comprises two standards M, located alongside the track at one side of the door; two standards M, located alongside the track at the opposite side of the door; rock-shafts N, journaled in the standards nearest the door and having depending cranks *g* at their inner ends; rock-shafts P, journaled in the standards M remote from the door and having depending cranks *h* at their inner ends and upwardly-extending arms *i* at their outer ends; shoes Q Q', loosely connected to the cranks *g h*, disposed longitudinally over one of the track-rails C and having their ends turned upwardly, as indicated by

j; a transverse shaft R, Fig. 5, journaled in bearings on the uprights E and having grooved pulleys S at its ends and also having grooved pulleys T at an intermediate point of its length; 5 cables U, connecting and designed to be wound on the pulleys *d* of the drums G and the pulleys S of the shaft R; a cable V, connecting one of the arms *i* and one pulley T and wound in one direction on the latter, and a cable W, 10 connecting the other arm *i* and the other pulley T and wound in the opposite direction with reference to the cable V on said pulley T.

The operation of the construction just described is as follows: When a mine-car is moving 15 on the track-rails C in the direction indicated by arrow in Fig. 1, the tread of one of its wheels will engage the shoe Q and raise and move the same in the direction of the arrow, this latter because of the friction between the tread of the wheel and the shoe. 20 The movement of the shoe Q in the direction stated will throw the arm *i* of its complementary crank P in the opposite direction, when, through the medium of the cable V, the shaft 25 R will be rotated in the direction of the arrow on the pulley S, Fig. 2, the cables U will be drawn off the pulleys *d* by the pulleys S to rotate the drums G, and the flexible sections I will be wound on the drums and the door will 30 be opened. When the door is thus opened, the sections H will be drawn well within the pockets B, and hence the door will offer no obstruction to the car, with the result that there is no liability of derailing the car at the entrance. 35 The opening of the door, as stated, raises the weights K, and when the car has passed the door said weights descend, and thereby close the door and wind the cables U on the pulleys *d* of the drums G and by so doing effect the 40 winding of the cables V and W on their drums T. When the wheel of the car traveling in the direction indicated by arrow engages the shoe Q', it will have no effect other than to raise and move said shoe Q' toward the left, 45 Fig. 1, and thereby throw the arm *i* complementary to said shoe Q' toward the right and slack the cable W, so as to permit the same to be easily wound on its drum T. When, however, the car approaches the door from the 50 left, Fig. 1, its wheel will engage and move the shoe Q' toward the right, when, through the instrumentalities described, the door will be opened and held open until the car passes the same. From the foregoing it follows that 55 when a car approaches the door in either direction the door will be automatically opened and held open until the car passes, and will then be automatically closed.

In Figs. 6 and 7 I have shown modified 60 means for opening one section H and the section I, connected thereto, when the shaft R is rotated in the direction indicated by arrow, Figs. 6 and 7, and for closing said sections H and I when the shaft R is released and free 65 to rotate in the direction opposite to that in-

dicated by arrow. I have deemed it unnecessary to illustrate the means for opening and closing the sections H and I under the conditions stated, since said means is similar 70 in all respects to that shown. The means shown comprises a lever K', fulcrumed at an intermediate point of its length on one upright arm; and having a weight L' on its outer 75 arm; a link M', connecting the inner arm of said lever and the adjacent section H; a lever N', fulcrumed at the same point as lever K'; a link P', connecting the inner arm of lever N' and the section H; a cable R', passed under a sheave S' and over a sheave T' and connecting 80 the outer arm of the lever N' and the pulley S on the shaft R, and a cable U', passed over the sheave T' and connecting the outer arm of lever K' and the pulley S. When the shaft R and pulley S are rotated in the direction 85 indicated by arrow by the means shown in Figs. 1 to 5, the cables R' and U' will be wound on the pulley S and the sections H and I will be opened through the medium of the levers K' and N', while when said shaft R and pulley 90 S are released and free to turn in the direction opposite to that indicated by arrow the weight L' will descend, and thereby close the sections H and I. To take up slack of the flexible section I incident to the opening of 95 the sections H and I, I provide the weight Z, which is lighter than the weight L'. Said weight Z is connected by a cable Z', which takes over a sheave Z', with a pulley *d* on the upper end of the drum G, and hence it will 100 be seen that it will descend when the section H is moved into its open position and rotate the drum G and effect the winding of the flexible section I thereon.

Notwithstanding their advantages, as pointed out in the foregoing, it will be observed that 105 my improvements are simple and inexpensive and embody no complicated parts, such as are liable to get out of order after a short period of use.

I have entered into a detailed description of 110 the construction and relative arrangement of the parts embraced in the present and preferred embodiment of my invention in order to impart a full, clear, and exact understanding of 115 the same. I do not desire, however, to be understood as confining myself to such specific construction and arrangement of parts, as such changes or modifications may be made in practice as fairly fall within the scope of my invention as claimed. 120

Having described my invention, what I claim, and desire to secure by Letters Patent, is—

1. The combination of a railway-track, a 125 frame having uprights disposed at opposite sides of the track, an overhead track-rail connected to the frame, and resting above the track, vertical drums carried by the frame, and arranged at opposite sides of the track, a door comprising sections H movable on the 130

overhead rail, and flexible sections I, connected to the sections H, and also connected to and adapted to be wound on the drums, a rotary shaft mounted on the frame, connections between said shaft and the door-sections for opening the latter by the former, supports arranged alongside the track and at different distances from the door, a rock-shaft journaled in the support nearest the door, and having a crank, a rock-shaft journaled in the support remote from the door, and having a crank, and also having an arm, a shoe loosely connected to the cranks of the rock-shafts and disposed longitudinally above a rail of the track whereby it is adapted to be raised and moved longitudinally by a wheel passing between it and said rail, a connection between the arm of the rock-shaft and the rotary shaft, and means for moving the door-sections to a closed position subsequent to the passage of a car.

2. The combination of a vertical drum having a pulley, a door comprising a flexible portion connected to and adapted to be wound on the drum, vertically-movable levers fulcrumed at an intermediate point of their length, connections between the inner arms of said levers and the door, a weight L on the outer arm of one lever, a rotary shaft, connections between the rotary shaft and the levers for moving the latter by the former, a weight Z, and a cable connected to said weight, and passed over a sheave, and connected to and wound on the pulley of the drum.

3. The combination of a passage in a mine or the like having pockets in its side walls, a railway-track extending through said passage, a frame having uprights arranged in the pockets, an overhead track-rail connected to the frame, and resting above the track, vertical drums carried by the frame, and arranged in the pockets, a door comprising sections H movable on the overhead rail, and flexible sections I, connected to the sections H, and also connected to and adapted to be wound on the drums, a rotary shaft mounted on the frame, and having a drum, connections between said shaft and the door-sections for opening the latter by the former, a device arranged to be engaged and moved by a part of a car traveling on the track, a connection between said device

and the drum on the rotary shaft for rotating the shaft by the device, and means for moving the door-sections to a closed position subsequent to the passage of a car. 55

4. The combination of a passage in a mine or the like having pockets in its side walls, a railway-track extending through said passage, a frame having uprights arranged in the pockets, an overhead track-rail connected to the frame, and resting above the track, vertical drums carried by the frame, and arranged in the pockets, a door comprising sections H movable on the overhead rail, and flexible sections I, connected to the sections H, and also connected to and adapted to be wound on the drums, a rotary shaft mounted on the frame, and having drums, connections between said shaft and the door-sections for opening the latter by the former, devices disposed at opposite sides of the door, and arranged to be engaged and moved by a part of a car traveling on the track, a connection between said devices and the drums on the rotary shaft for rotating the shaft by the devices, and means for moving the door-sections to a closed position subsequent to the passage of a car in either direction. 60 65 70 75

5. The combination of a railway-track, a vertical drum mounted at one side of the same, and having a pulley, a door movable, in a guideway, crosswise of the track, and comprising a flexible portion connected to and adapted to be wound on the drum, a rotary shaft having a pulley, vertically-movable levers fulcrumed at an intermediate point of their length, connections between the inner arms of said levers and the door, a weight on the outer arm of one lever, connections between the rotary shaft and the levers for moving the latter by the former, a weight, and a cable connected to said weight, and passed over a sheave, and connected to and wound on the pulley of the drum. 80 85 90

In testimony whereof I have hereunto set my hand in presence of two subscribing witnesses. 95

ALBERT H. LEWIS.

Witnesses:

J. LESLIE HILLYER,
D. C. THOMPSON.