



US 20070118202A1

(19) **United States**

(12) **Patent Application Publication** (10) **Pub. No.: US 2007/0118202 A1**

Chermoni (43) **Pub. Date: May 24, 2007**

(54) **BALLOON CATHETER FOR MULTIPLE ADJUSTABLE STENT DEPLOYMENT**

(30) **Foreign Application Priority Data**

Mar. 29, 2001 (IL) 142332

(75) Inventor: **Israel Chermoni, Haifa (IL)**

Publication Classification

Correspondence Address:

**LEVINE BAGADE HAN LLP
2483 EAST BAYSHORE ROAD, SUITE 100
PALO ALTO, CA 94303 (US)**

(51) **Int. Cl.**

A61F 2/84 (2006.01)

(52) **U.S. Cl.** 623/1.11

(73) Assignee: **XTENT, INC., Menlo Park, CA (US)**

(57) **ABSTRACT**

(21) Appl. No.: **11/625,232**

(22) Filed: **Jan. 19, 2007**

A catheter configured to carry one or more stents and having an inflatable balloon for expanding a stent surrounding the balloon. The catheter is characterized in having a positioner for moving the one or more stents relative to the balloon from a first position in which the stent does not surround the balloon to a second position in which the stent surrounds the balloon. Also disclosed is a method for deploying a stent at a desired location in the vascular system.

Related U.S. Application Data

(63) Continuation of application No. 11/421,653, filed on Jun. 1, 2006, which is a continuation of application No. 10/108,985, filed on Mar. 29, 2002, now Pat. No. 7,147,655.

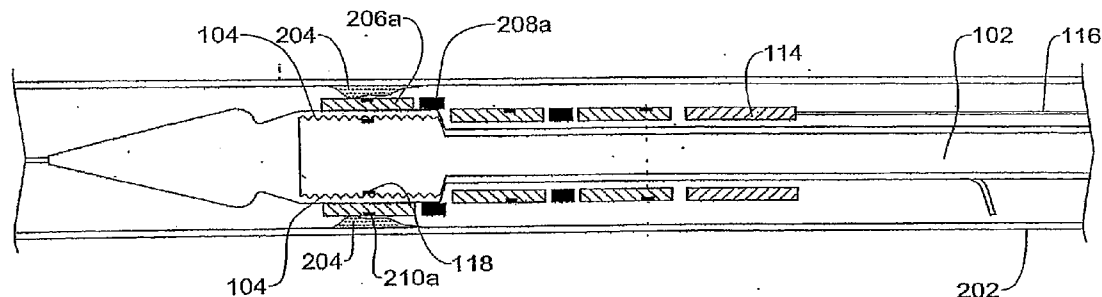

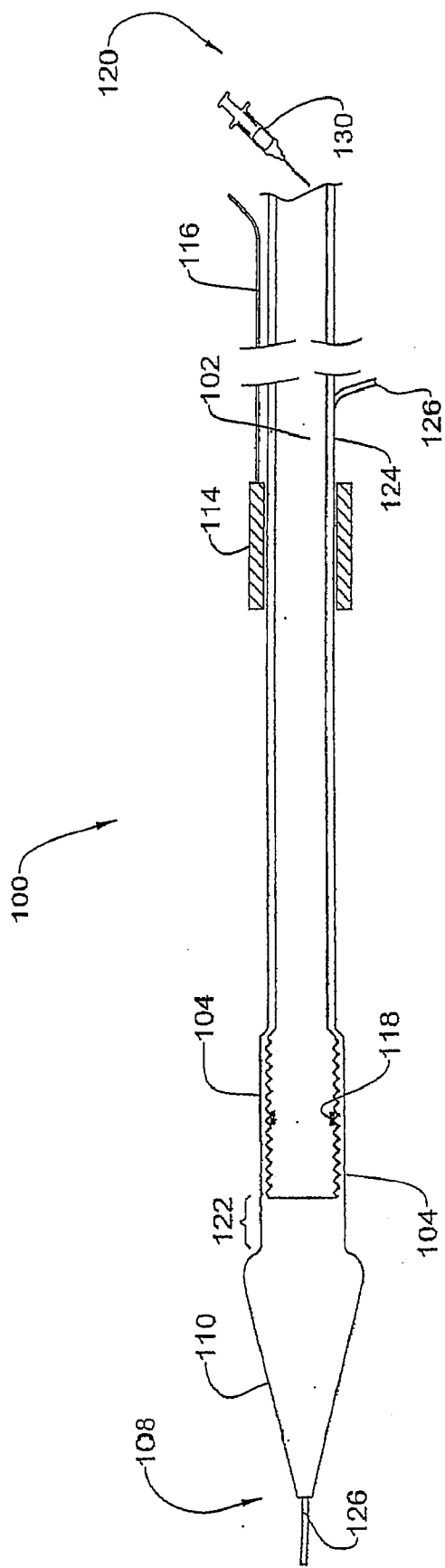

FIG. 1

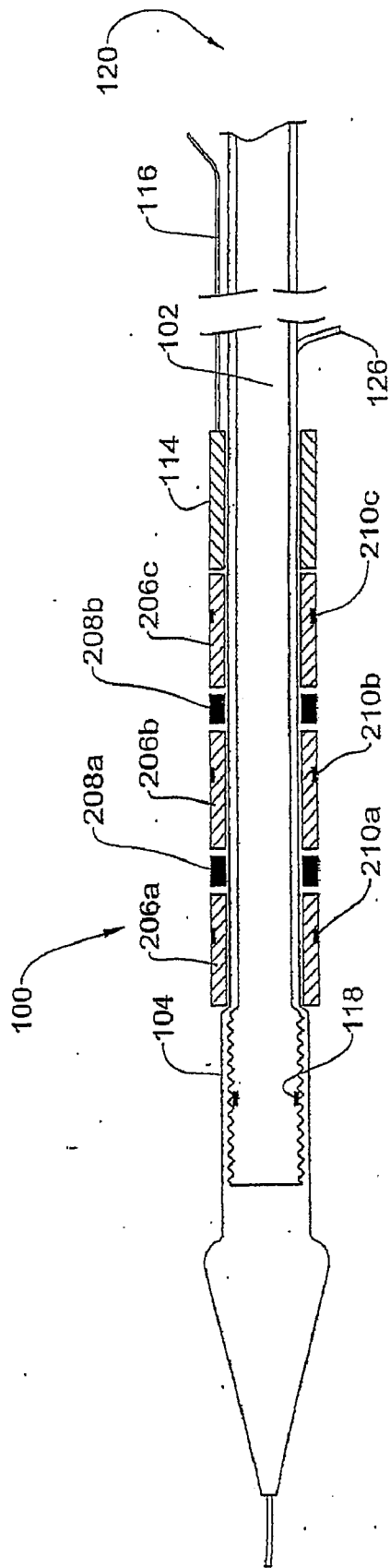

FIG. 2

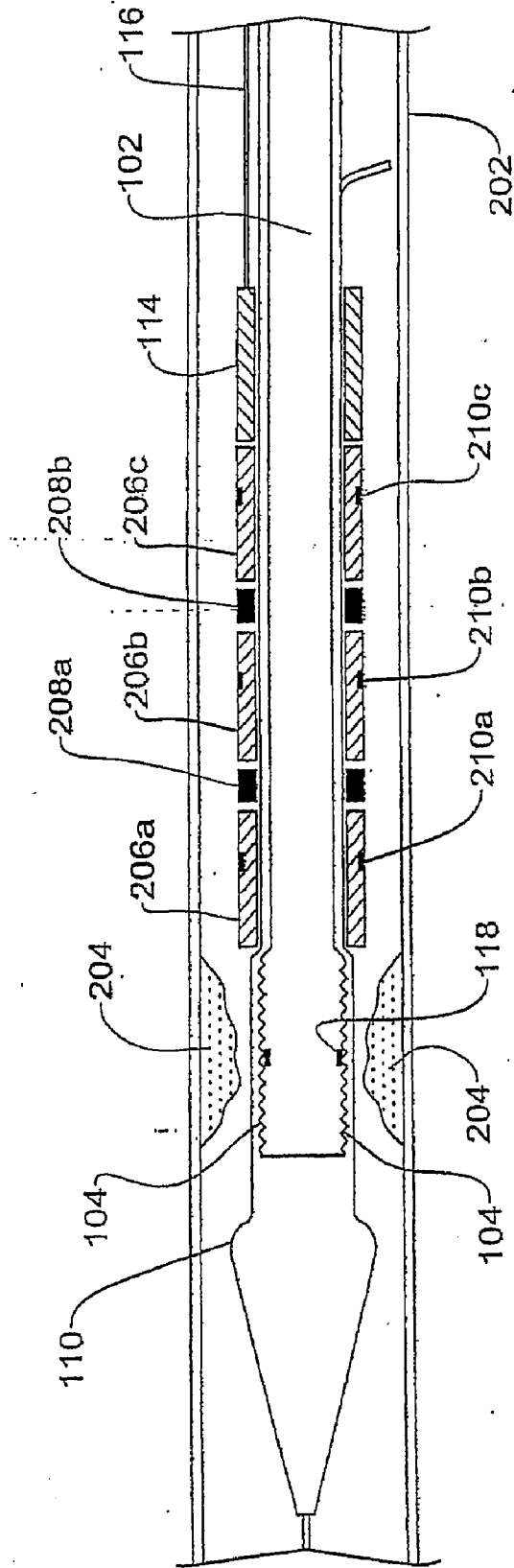

FIG. 3

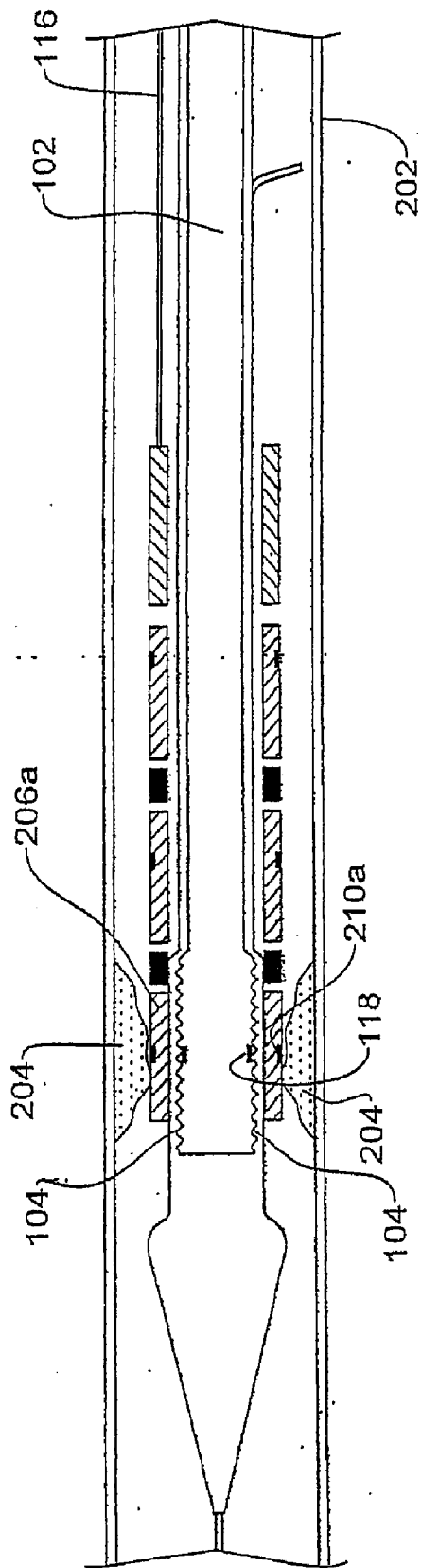

FIG. 4

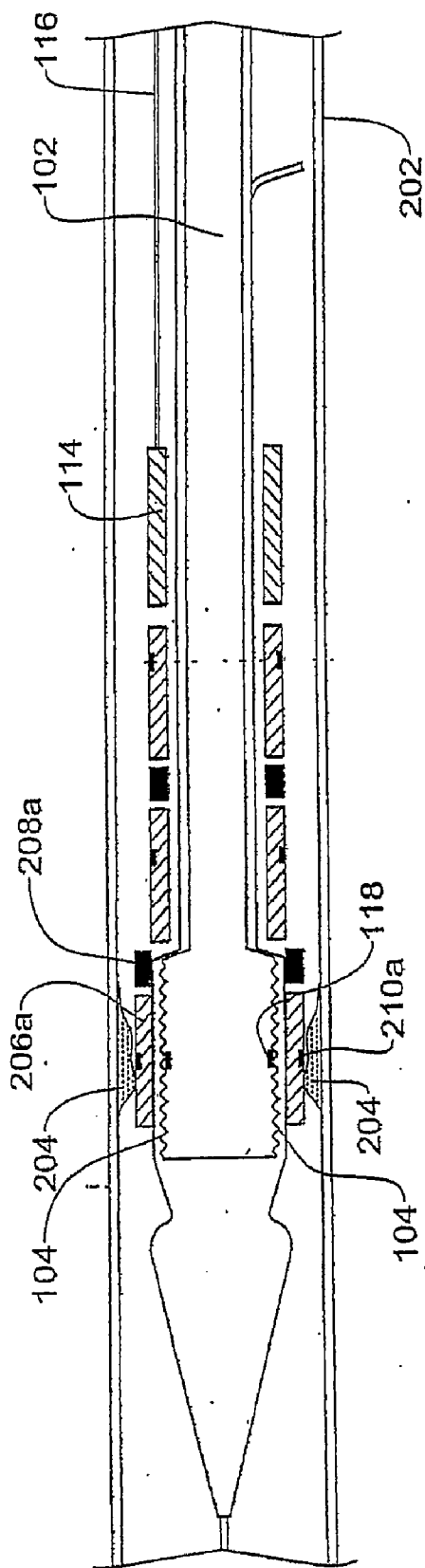

FIG. 5

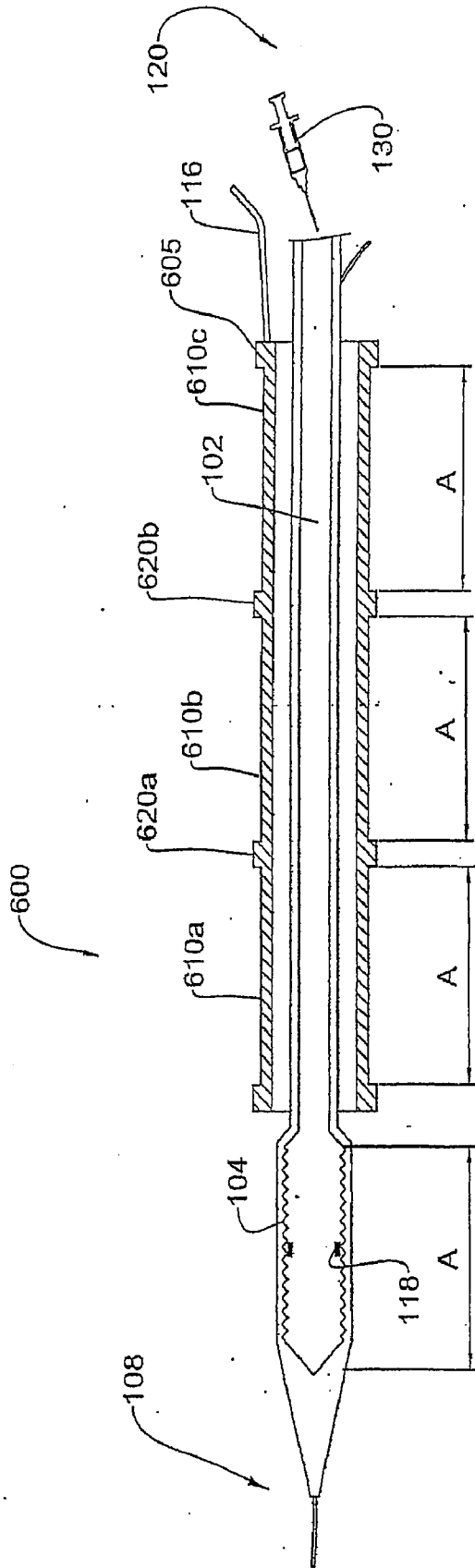

FIG. 6

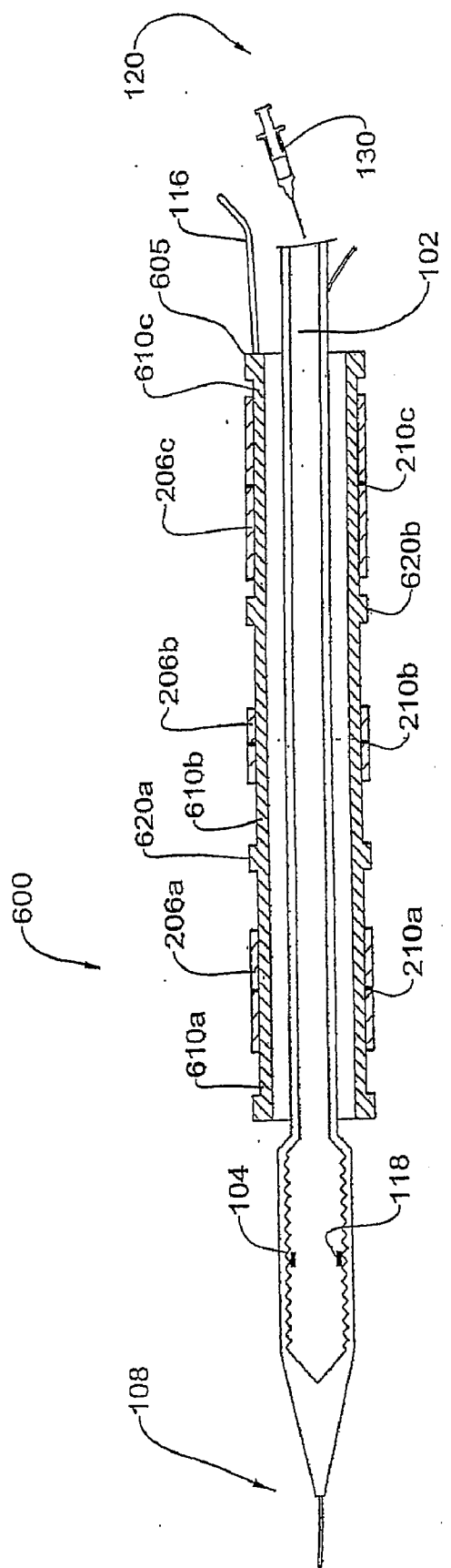

FIG. 7

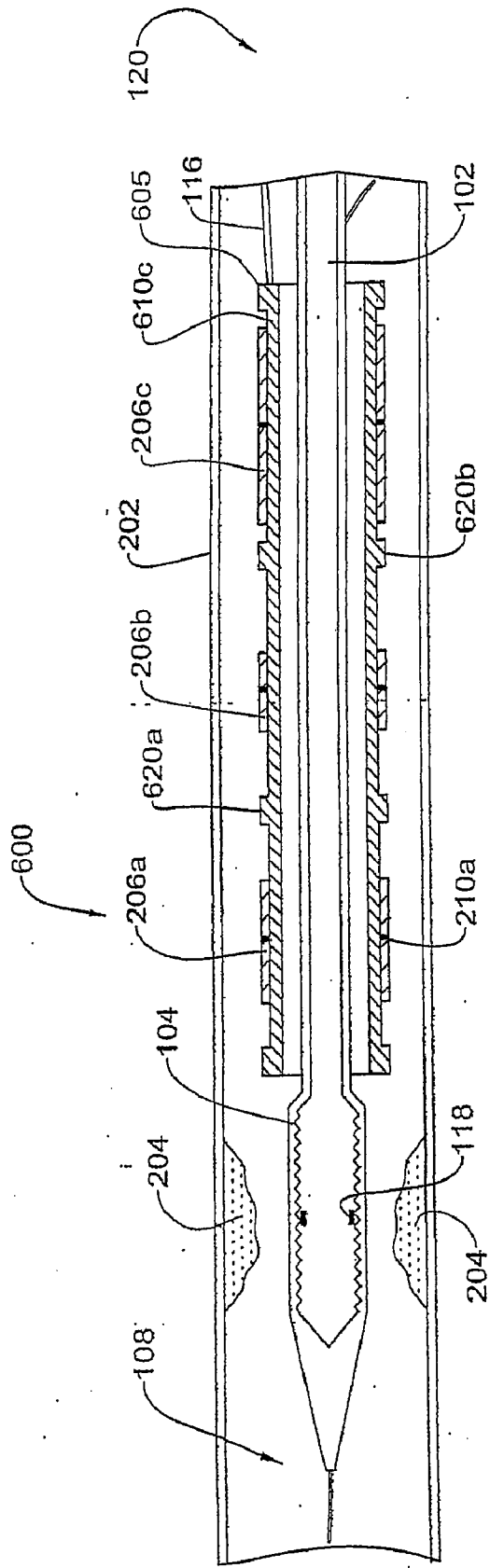

FIG. 8

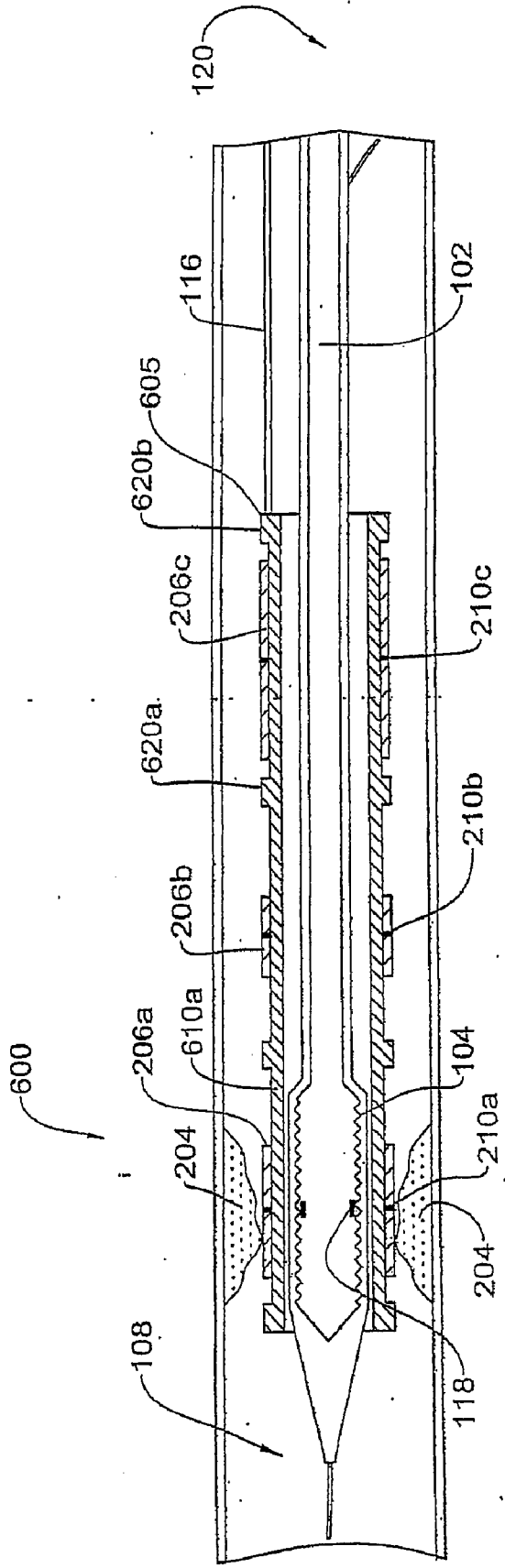

FIG. 9

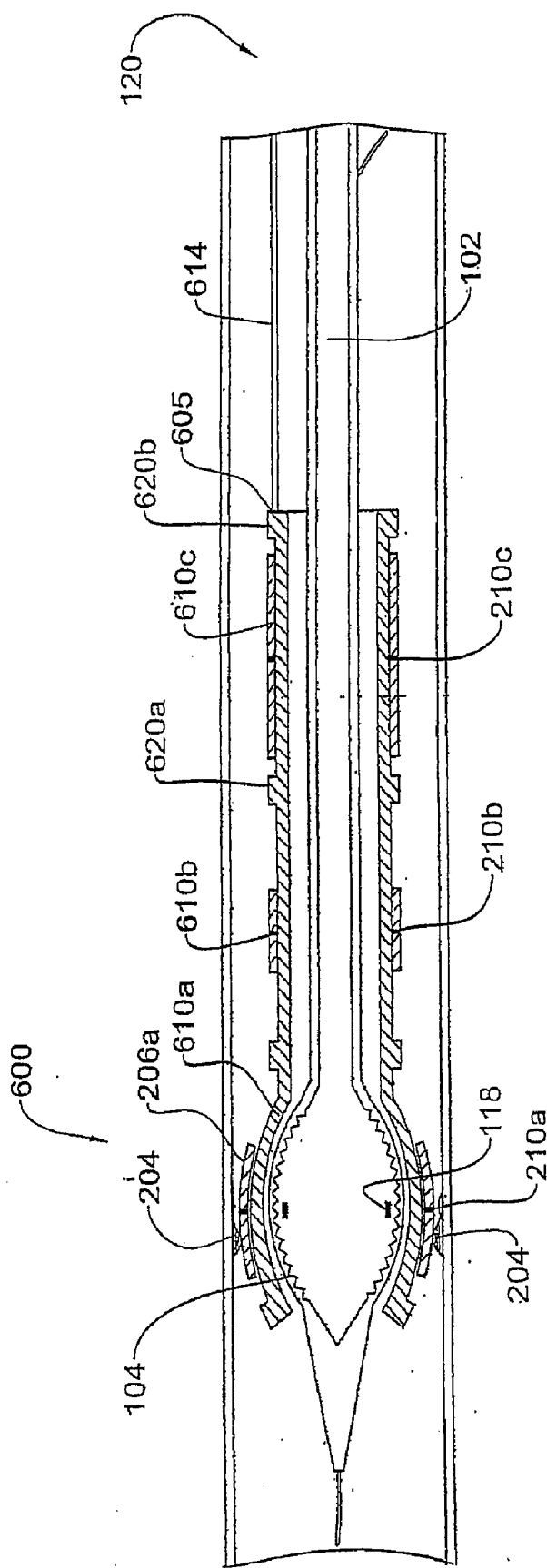

FIG. 10

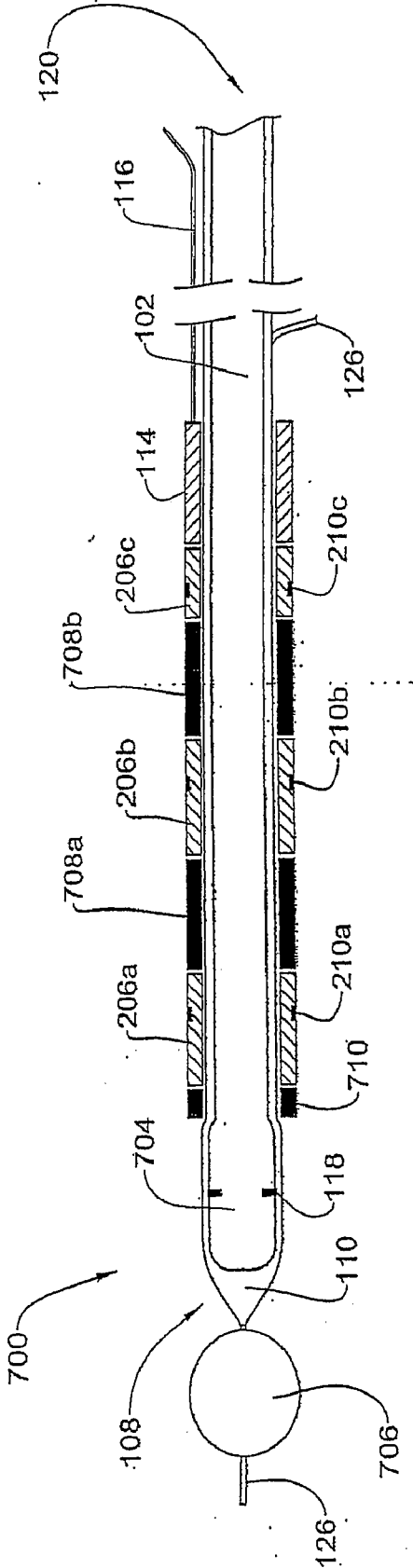

FIG. 11

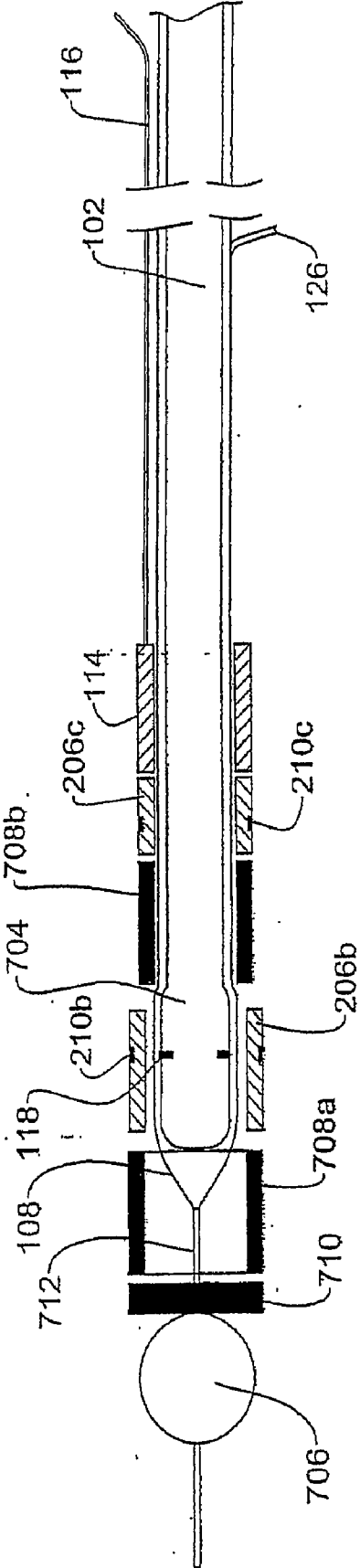

FIG. 12

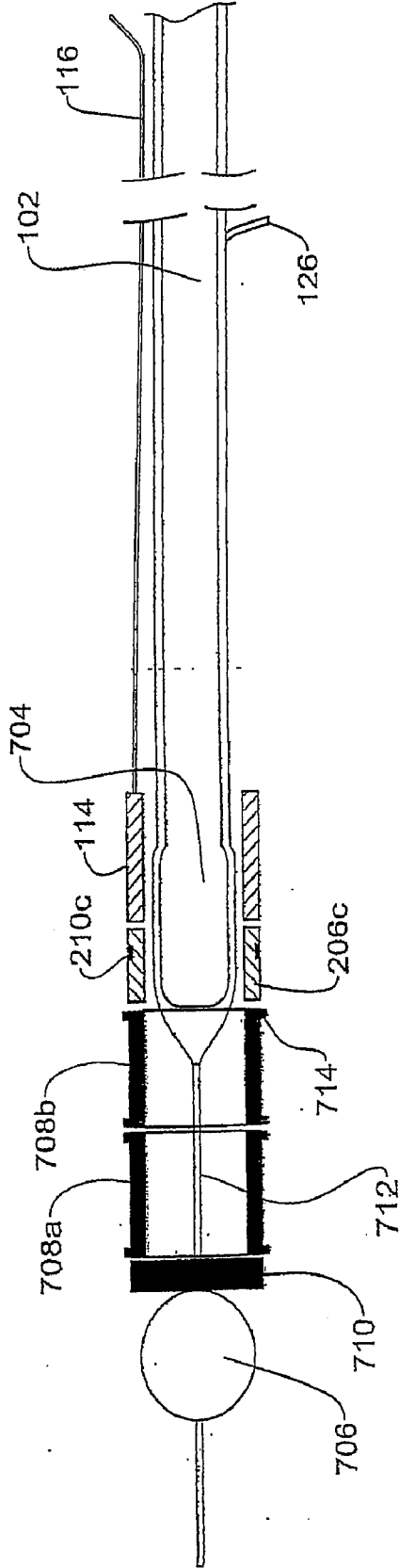

FIG. 13

BALLOON CATHETER FOR MULTIPLE ADJUSTABLE STENT DEPLOYMENT

RELATED APPLICATION DATA

[0001] This application is a continuation of U.S. application Ser. No. 11/421,653 filed Jun. 1, 2006, which is a continuation of U.S. application Ser. No. 10/108,985 filed Mar. 29, 2002, which claims the benefit of foreign priority to IL 142332 filed Mar. 29, 2001, each of which application is hereby incorporated by reference in its entirety.

FIELD OF THE INVENTION

[0002] This invention relates to catheters and more specifically to such catheters that are used to implant a stent in an artery.

BACKGROUND OF THE INVENTION

[0003] Blood vessels, and particularly arteries, may become stenotic or occluded due to various atherosclerotic processes. A stenotic artery may be treated by balloon angioplasty in which an inflatable balloon mounted on a catheter tip is inserted into the arterial system and navigated through the arterial system to the diseased artery. The balloon is then inflated by means of a pressurized fluid. This causes the balloon to press radially on the arterial wall so as to open the stenosis. A stent may be crimped onto the balloon before insertion so that when the balloon is inflated the stent becomes expanded. The balloon is deflated and withdrawn leaving the expanded stent in the artery. These and other similar methods are well known to the skilled man of the art.

[0004] It is often necessary to treat several stenoses in a single angioplastic session. For example, it may be necessary to insert a large diameter stent at one location, a small diameter stent at a second location and to perform a balloon angioplasty without a stent at a third location. This could be accomplished by sequential insertion and withdrawal of a catheter, the catheter being loaded each time with the appropriate stent prior to insertion. This however would cause much discomfort to the patient, prolongs the duration of the procedure and increases the chances of damaging a blood vessel.

[0005] U.S. Pat. No. 6,027,519 discloses a catheter for deploying one or more stents. The stent has one or more individually expandable segments along its length. A stent, in its unexpanded state, is loaded onto each expandable segment of the catheter. The catheter is inserted into the vascular system and positioned with the first expandable segment in a stenosis. An axial force is then applied to the segment causing it to buckle outwards and expand the stent. The force is then removed causing the segment to unbuckle leaving the stent in its expanded state. The catheter is then navigated to another stenosis. This process is repeated until all of the stents have been deployed.

SUMMARY OF THE INVENTION

[0006] The present invention provides a catheter for deploying one or more stents in a cardiovascular system. The catheter is configured to carry one or more stents. Preferably, the catheter carries a plurality of stents. The stents may be of different or the same widths. An inflatable balloon is used to expand a stent surrounding the balloon. The catheter comprises a positioner for moving a stent

relative to the balloon from a position in which the stent does not surround the balloon to a position that it does surround the balloon in order to prime the stent for expansion by the balloon. The phrase "for moving a stent relative to the balloon" includes two possibilities, i.e. moving the positioner relative to the balloon and moving the balloon relative to the positioner.

[0007] In one embodiment of the invention the positioner comprises an element configured to slide along the catheter and push the stents distally along the catheter so as to move a stent adjacent to the balloon into a position in which it surrounds the balloon. The sliding element is pushed along the catheter by means of a wire extending along the catheter from its proximal end to the sliding element. In this embodiment, the stents are deployed in the order in which they are carried by the catheter, starting with the stent closest to the balloon.

[0008] In another embodiment, the positioner comprises a flexible carriage configured to carry the one or more stents. The carriage is capable of sliding along the catheter in order to bring one of the stents from a position in which the stent does not surround the balloon to a position in which the stent surrounds the balloon. The carriage is moved in either direction along the catheter by means of a wire extending along the catheter from its proximal end to the carriage. It is also possible to position the stent opposite a desired location in the vascular system and slide the balloon through the carriage to a position opposite the stent. In this embodiment the stents may be deployed in the vascular system in any order.

[0009] It a third embodiment, the catheter comprises two positioners, one posterior positioner as described above in the first embodiment positioned posterior to the balloon, and a second anterior positioner positioned anterior to the balloon. In this embodiment, the anterior positioner may be distanced from the balloon so as to provide a storage space between the anterior positioner and the balloon. The balloon in this embodiment may be a conventional balloon used in balloon angioplasty. In this embodiment also, the stents may be deployed in the vascular system in any order, and may be of different lengths.

[0010] In use, the catheter is loaded with one or more stents and inserted into a vascular system. The catheter is navigated through the vascular system until the balloon or stent is positioned at a first desired location, typically the site of a stenosis. The stent or balloon is then moved by the positioner so that the stent surrounds the balloon and the balloon is inflated so as to expand the stent. The balloon is then deflated, leaving the expanded stent at the first desired location. This process may be repeated, each time deploying a different stent at a different location. After one or more of the stents have been deployed, the catheter may be removed from the vascular system.

[0011] The invention also provides a method for deploying a stent in a desired location of a vascular system comprising the steps of:

[0012] (a) inserting a catheter according to the invention carrying one or more stents into the vascular system,

[0013] (b) navigating the catheter through the vascular system until the balloon is positioned in the desired location;

- [0014] (c) moving a stent from a first position in which it does not surround the balloon to a second position in which it surrounds the balloon;
- [0015] (d) inflating the balloon so as to expand the stent; and
- [0016] (e) deflating the balloon.

BRIEF DESCRIPTION OF THE DRAWINGS

[0017] In order to understand the invention and to see how it may be carried out in practice, a preferred embodiment will now be described, by way of non-limiting examples only, with reference to the accompanying drawings, in which:

- [0018] FIG. 1 shows a catheter in accordance with one embodiment of the invention;
- [0019] FIG. 2 shows the catheter of FIG. 1 carrying stents;
- [0020] FIG. 3 shows the catheter at FIG. 1 inserted in a blood vessel;
- [0021] FIG. 4 shows the catheter of FIG. 1 with a stent surrounding a balloon on the catheter;
- [0022] FIG. 5 shows the catheter in FIG. 1 after inflation of the balloon;
- [0023] FIG. 6 shows a catheter in accordance with another embodiment of the invention;
- [0024] FIG. 7 shows the catheter of FIG. 6 carrying stents;
- [0025] FIG. 8 shows the catheter at FIG. 6 inserted in a blood vessel;
- [0026] FIG. 9 shows the catheter of FIG. 6 with a stent surrounding a balloon on the catheter;
- [0027] FIG. 10 shows the catheter in FIG. 6 after inflation of the balloon;
- [0028] FIG. 11 is a sectional side view of a catheter in accordance with another embodiment of the invention;
- [0029] FIG. 12 illustrates the operation of the embodiment illustrated in FIG. 11; and
- [0030] FIG. 13 illustrates another detail of the operation of the embodiment of FIG. 11.

DETAILED DESCRIPTION OF THE INVENTION

EXAMPLE I

[0031] FIG. 1 shows a catheter 100 for deploying stents in accordance with one embodiment of the invention. The catheter 100 has a distal end 108 and a proximal end 120. The catheter 100 comprises a flexible tube 102, which is connected to an inflatable balloon 104 proximate to its distal end. The balloon 104 is shown in the Figure in its deflated state. A radio-opaque marker 118 is located on the balloon wall. The catheter 100 has at its distal end 108 a tapered tip 110 that may be inserted into a stenosis in order to open the stenosis. A syringe 130 may be used to introduce a fluid into the tube 102 in order to inflate the balloon 104 as described in detail below.

[0032] A longitudinal shaft 124 in the wall of the tube 102 is configured to receive a guidewire 126 used in navigating the catheter in the vascular system. A neck region 122 of the tube 102 intervenes between the distal end of the balloon 104 and the tip 110. The proximal end of the tip 110 is broadened to form a shoulder at the distal end of the neck region 122. A sliding positioner element in the form of an annular sliding ring 114 is mounted on the tube 102 proximal to the balloon 104. The ring 114 is slidable along the tube 102 by means of a wire 116 that extends along the length of the tube 102 from the proximal end 120 of the catheter to the ring 114.

[0033] The sliding ring 114 and the wire 116 form a positioner for moving a stent from a position which it does not surround the balloon 104 to a position in which it surrounds the balloon 104.

[0034] FIG. 2 shows the catheter 100 having a plurality of stents (three are shown in FIG. 2) 206a, 206b and 206c, mounted on the tube 102 between the sliding ring 114 and the balloon 104. The stents are separated from each other by separating rings 208a and 208b. The sliding ring 114 has been positioned so that the separating rings 208a and 208b and the stent 206 are contiguous with the balloon 104. Each stent 206 bears a radio-opaque markers 210a, 210b and 210c.

[0035] In use, the catheter 100 is introduced into the vascular system and navigated to a stenosis by methods well known in the art. FIG. 3 shows the catheter 100 after having been navigated through the vascular system and positioned inside a blood vessel 202. The balloon is located opposite a stenotic region 204 of the blood vessel 202. The wire 116 is used to slide the sliding ring 114 distally along the tube 102 so as to push the stents 206a, 206b, 206c, distally. The sliding ring 114 is pushed distally along the tube 102 so that the stent 206a is pushed over and around the balloon 104, which is thereby brought into the lumen of the stent 206a, and the marker 118 on the balloon coincides with the marker 210a of the stent, as determined for example by x-ray angiography. FIG. 4 shows the stent 206a surrounding the balloon 104.

[0036] A fluid is then introduced into the tube 102. The fluid passes through the tube 102 and inflates the balloon 104. It will be understood that the balloon may be inflated by other conventional means, as are known in the art. Inflation of the balloon 104 expands the stent 206a onto the stenotic region of the blood vessel 202, as shown in FIG. 5.

[0037] The fluid is then withdrawn from the tube 102. Withdrawal of the fluid from the tube 102 causes the balloon to deflate. After deflation of the balloon, the stent 206a remains in situ in its expanded state.

[0038] The catheter may then be navigated through the arterial system until the catheter is positioned with the balloon 104 at another stenotic region of a blood vessel. The sliding ring is pushed distally by the wire 116 so that the succeeding stent 206b overlies the balloon 104 and the marker 118 coincides with the marker 210b on the stent 206b. The distal separating ring 208a is pushed along the tube 102, beyond the balloon 104 to the neck region 122 of the tube, where the separating rings are stored. The shoulder of the tip 110 retains the separating rings on the neck region. This process may be repeated until some or all of the stents 206 have been deployed. The catheter is then removed from the body.

EXAMPLE II

[0039] FIG. 6 shows a catheter 600 for deploying stents in accordance with another embodiment of the invention. The embodiment of FIG. 6 has many components in common with the embodiment of FIG. 1, and similar components are identified by the same reference numeral in both embodiments.

[0040] The embodiment of FIG. 6 has a cylindrical carriage 605 mounted on the tube 102. The carriage has a plurality of annular depressions (three are shown in FIG. 6) 610a, 610b and 610c configured to receive a stent as described below. The depressions 610 all have the same length A as indicated in FIG. 6, which is essentially equal to the length of the balloon 104. Between the depressions 610 are barriers 620a and 620b. The carriage 605 is made from an elastic material such as rubber. The carriage 605 is slidable along the tube 102 by means of a wire 116 that extends along the length of the tube 102 from the proximal end 120 of the catheter to the carriage 605. The carriage 605 and the wire 116 form a positioner for moving a stent from a position in which it does not surround the balloon 104 to a position in which it surrounds the balloon 104.

[0041] FIG. 7 shows the catheter 600 having a plurality of stents (three are shown in FIG. 7) 206a, 206b and 206c mounted on the annular depressions of the tube 102. The stents are separated from each other by the barriers 620a and 620b. In the present embodiment the stents are of different lengths. However, they may also be of the same length. Each stent 206 bears a radio-opaque annular marker 210a, 210b and 210c.

[0042] The catheter 600 is introduced into the vascular system and navigated to a stenosis by methods well known in the art. FIG. 8 shows the catheter 600 after having been navigated through the vascular system and positioned inside a blood vessel 202. The balloon is located within a stenotic region 204 of the blood vessel 202. The wire 116 is used to slide the cage 605 distally along the tube 102 so as to move the stents 206 distally. The carriage 605 is pushed distally along the tube 102 until the balloon 104 is brought into the lumen of the stent 206a and the marker 118 on the tube coincides with the marker 210a, as determined for example by x-ray angiography. In a similar manner, the balloon may be slid within the carriage until it is positioned opposite the stent. FIG. 9 shows the stent 206a surrounding the balloon 104.

[0043] A fluid is then introduced into the tube 102. The fluid passes through the tube 102 and inflates the balloon 104. Inflation of the tube 104 expands the portion of the carriage 605 surrounding the balloon 104 which in turn expands the stent 206a onto the stenotic region of the blood vessel 202, as shown in FIG. 10.

[0044] The fluid is then withdrawn from the tube 102 into the syringe 130. Withdrawal of the fluid from the tube 102 causes the balloon to deflate. After deflation of the balloon, the stent 206a remains in its expanded state.

[0045] The catheter is then navigated through the arterial system until the catheter is positioned with the balloon 104 in another stenotic region of a blood vessel. The catheter is then pushed distally by the wire 116 so that the stent 206b overlies the balloon 104 and the marker 118 coincides with the marker 210b on the stent 206b. In this embodiment, the

stents may be deployed in any order. This process may be repeated until some or all of the stents 206 have been deployed. The catheter is then removed from the body.

EXAMPLE III

[0046] This example illustrates an embodiment which is an improvement over the embodiment described in Example I. With reference to FIG. 11, there is shown a catheter 700 having a distal end 108 and a proximal end 120. As in FIG. 1, the catheter 700 comprises a flexible tube 102, which is connected to an inflatable balloon 704 proximate to its distal end. A radio-opaque marker 118 is located on the balloon wall. The catheter 700 has at its distal end 108 a tapered tip 110, but unlike in Example I, there is no neck region, and the tip is not enlarged. The balloon in this embodiment may be a conventional inflatable balloon used in balloon angioplasty.

[0047] As in Example I, a guidewire 126 extends along the tube 102, exiting at the distal end 108 of the catheter. An anterior positioner in the form of a perforated sphere 706 is fixed to the guidewire anterior to the balloon 704, e.g. the guidewire passes through a bore channel extending through the sphere. The diameter of the sphere is slightly larger than the diameter of the retracted stents which are mounted on the catheter. The purpose of the sphere will be explained below.

[0048] The catheter 700 has a sliding ring 114 (being the posterior positioner) and a plurality of stents (three are shown in FIG. 11) 206a, 206b and 206c, mounted on the tube 102 between the sliding ring 114 and the balloon 704. While the anterior stents are generally of the same length, the posterior stent may be longer or shorter. In the illustrated embodiment, the posterior stent 206c is shorter than the other stents. Each stent 206 bears at least one radio-opaque marker 210a, 210b and 210c, respectively. The stents are separated by separating rings 708a and 708b which are of the same length as the anterior stents. An anterior ring 710 is positioned between the most anterior stent 206a and the balloon 704 and protects the distal edge of the anterior stent. This anterior ring may be shorter than the separating rings.

[0049] The operation of this embodiment may be understood with reference to FIG. 12. As in Example I, the wire 116 is used to slide the sliding ring 114 distally along the tube 102 so as to push the stents 206a, 206b, 206c, distally. The sphere 706 is distanced from the distal end 108 of the catheter by pushing the guidewire 126, thus providing free guidewire 712 on which components of the catheter may be stored. In FIG. 12, it may be seen that the anterior ring 710 and the separating ring 708a have been pushed beyond the balloon 704 and onto the free guidewire 712. The anterior stent 206a (not shown) has been expanded and deployed within the blood vessel wall, and the middle stent 206b is mounted on the balloon 704, ready to be expanded. The radio-opaque marker 210b of the stent 206b is positioned opposite the radio-opaque marker 118 of the balloon 704.

[0050] Thus, this embodiment also differs from that of Example I in having more room to store the separating rings. In addition, all of the mounted stents and rings may be moved distally and proximally by pulling and pushing the anterior and posterior positioners, being the sphere 706 and sliding ring 114, respectively, so that the stents may be deployed in any order. This differs from Example I where the

stents were required to be deployed in the order in which they were placed on the catheter.

[0051] FIG. 13 shows the catheter after the 2 anterior stents 206a and 206b (not shown) have been deployed, and the anterior 710 and separating 708a & 708b rings are positioned on the free guidewire 712 between the sphere 706 and the balloon 704. It may be seen that the separating rings have annular protrusions 714 protruding from their outer surface. The purpose of these protrusions is to protect the blood vessel inner wall from being injured by the stents as the catheter travels through the vessel. The posterior stent 206c is mounted on the distal half of the balloon 704, while the anterior portion of the sliding ring 114 envelops the proximal end of the balloon. Thus, when the balloon is inflated, only the distal half expands (since the sliding ring resists the pressure of the balloon), expanding the stent 206c and deploying it in the blood vessel.

What is claimed is:

1. A method of delivering a stent system, comprising:
 - intravascularly advancing a catheter proximate or adjacent to a first lesion, the catheter having a distal end, an inflatable balloon near the distal end, and a plurality of stents, wherein a first stent having a first length surrounds the balloon;
 - expanding the first stent along the first lesion;
 - repositioning the catheter proximate or adjacent to a second lesion;
 - positioning a second stent having a second length to surround the balloon, the second length being different than the first length;
 - expanding the second stent along the second lesion.
2. The method of claim 1 wherein positioning comprises urging a sliding element along the catheter to push the plurality of stents distally along the catheter so as to move the second stent adjacent to the balloon into a position in which it surrounds the balloon.
3. The method of claim 2 wherein urging the sliding element comprises urging a proximal end of a wire attached to the sliding element and extending longitudinally along a length of the catheter such that the sliding element slides along the catheter in response to a longitudinal movement of the wire.
4. The method of claim 1 wherein positioning comprises moving the plurality of stents simultaneously along the catheter.
5. The method of claim 1 wherein positioning comprises urging a carriage upon which the plurality of stents are positioned distally along the catheter so as to move the second stent adjacent to the balloon into a position in which it surrounds the balloon.
6. The method of claim 1 wherein prior to expanding the first stent, slidably adjusting a constraining member over the balloon to constrain a portion of the balloon from expanding.
7. The method of claim 1 wherein expanding the first stent comprises expanding the balloon within the first stent such that a length of the expanded balloon is coextensive with a length of the first stent.
8. The method of claim 1 wherein prior to expanding the first stent, selecting the first stent to have a length coextensive with a length of the first lesion.

9. The method of claim 1 wherein prior to expanding the first stent, separating the first stent to be expanded from the second stent adjacent to the first stent via a separating mechanism which is movable relative to the balloon.

10. The method of claim 1 wherein repositioning the catheter comprises repositioning the plurality of stents proximate or adjacent to the second lesion at a location separate from the first lesion.

11. The method of claim 1 wherein prior to expanding the second stent, adjusting an expandable portion of the balloon such that the balloon expands along a length which is coextensive with a length of the second stent.

12. The method of claim 1 wherein prior to expanding the second stent, slidably adjusting a constraining member over the balloon to constrain a portion of the balloon from expanding.

13. The method of claim 1 wherein expanding the second stent comprises expanding the balloon within the second stent such that a length of the expanded balloon is coextensive with a length of the second stent.

14. The method of claim 1 wherein prior to expanding the second stent, selecting the second stent to have a length coextensive with a length of the second lesion.

15. A method of delivering a stent system, comprising:

- intravascularly advancing a catheter proximate or adjacent to a first lesion, the catheter having a distal end, an inflatable balloon near the distal end, and a plurality of stents, wherein one or more stents having a first total length are positioned proximate or adjacent to the first lesion;

expanding the one or more stents having the first total length along the first lesion via the balloon;

repositioning the catheter with respect to a second lesion;

positioning at least one or more additional stents having a second total length which is different from the first total length are positioned proximate or adjacent to the second lesion;

expanding the one or more additional stents along the second lesion via the balloon.

16. The method of claim 15 wherein positioning comprises urging a sliding element along the catheter to push the plurality of stents distally along the catheter so as to move the plurality of stents adjacent to the balloon into a position in which at least the one or more stents having the second total length surrounds the balloon.

17. The method of claim 16 wherein urging the sliding element comprises urging a proximal end of a wire attached to the sliding element and extending longitudinally along a length of the catheter such that the sliding element slides along the catheter in response to a longitudinal movement of the wire.

18. The method of claim 15 wherein positioning comprises moving the plurality of stents simultaneously along the catheter.

19. The method of claim 15 wherein positioning comprises urging a carriage upon which the plurality of stents are positioned distally along the catheter so as to move the one or more stents having the second total length adjacent to the balloon into a position in which it surrounds the balloon.

20. The method of claim 15 wherein prior to expanding the one or more stents, slidably adjusting a constraining member over the balloon to constrain a portion of the balloon from expanding.

21. The method of claim 15 wherein expanding the one or more stents having the first total length comprises expanding the balloon within the one or more stents such that a length of the expanded balloon is coextensive with a length of the one or more stents.

22. The method of claim 15 wherein prior to expanding the one or more stents, selecting the one or more stents to have a length coextensive with a length of the first lesion.

23. The method of claim 15 wherein prior to expanding the one or more stents, separating the one or more stents to be expanded from the one or more additional stents adjacent to the one or more stents via a separating mechanism which is movable relative to the balloon.

24. The method of claim 15 wherein repositioning the catheter comprises repositioning the plurality of stents proximate or adjacent to the second lesion at a location separate from the first lesion.

25. The method of claim 15 wherein prior to expanding the one or more additional stents, adjusting an expandable

portion of the balloon such that the balloon expands along a length which is coextensive with a length of the one or more additional stents.

26. The method of claim 15 wherein prior to expanding the one or more additional stents, slidably adjusting a constraining member over the balloon to constrain a portion of the balloon from expanding.

27. The method of claim 15 wherein expanding the one or more additional stents comprises expanding the balloon within the one or more additional stents such that a length of the expanded balloon is coextensive with a length of the one or more additional stents.

28. The method of claim 15 wherein prior to expanding the one or more additional stents, selecting the one or more additional stents to have a length coextensive with a length of the second lesion.

* * * * *