



US 20090107737A1

(19) **United States**  
(12) **Patent Application Publication**  
**Reynolds et al.**

(10) **Pub. No.: US 2009/0107737 A1**  
(43) **Pub. Date: Apr. 30, 2009**

(54) **MULTIPLE-SENSOR-ELECTRODE CAPACITIVE BUTTON**

**Related U.S. Application Data**

(60) Provisional application No. 61/000,784, filed on Oct. 28, 2007.

(76) Inventors: **Joseph K Reynolds**, Mountain View, CA (US); **Tracy Scott Dattalo**, Santa Clara, CA (US); **John C Fravel**, San Jose, CA (US); **Izhak Baharav**, Palo Alto, CA (US); **John M Feland, III**, Sa Jose, CA (US)

**Publication Classification**

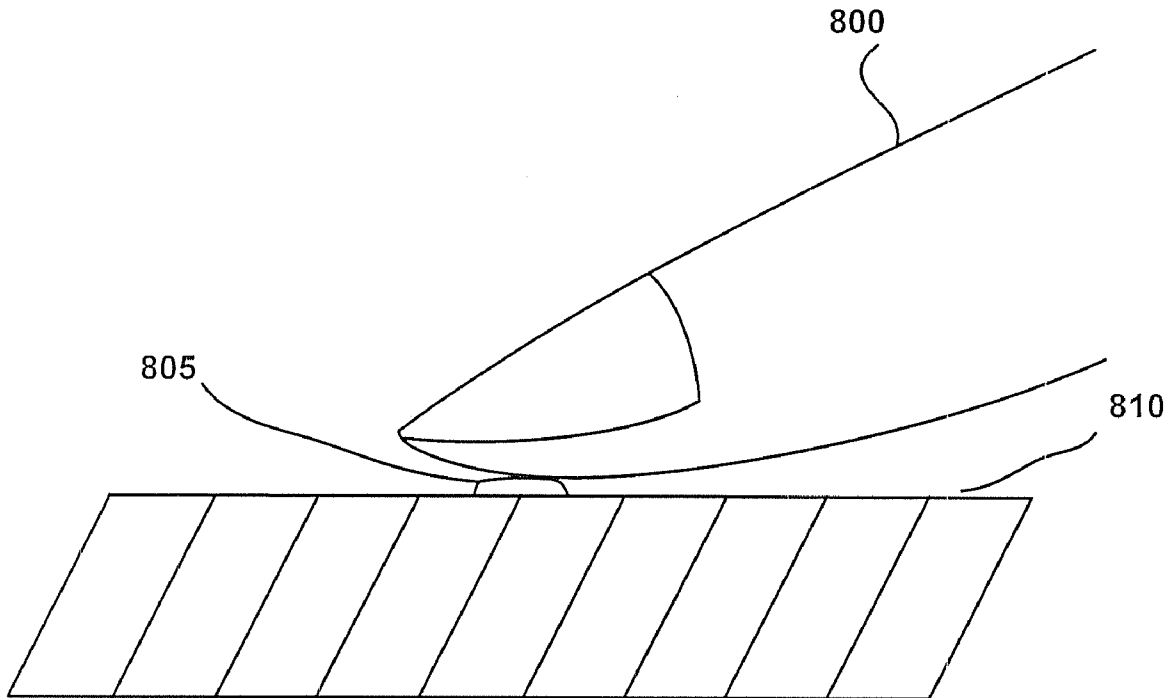
(51) **Int. Cl.** *G08C 21/00* (2006.01)  
(52) **U.S. Cl.** ..... **178/18.06**

Correspondence Address:  
**SYNAPTICS C/O WAGNER BLECHER LLP**  
**123 WESTRIDGE DRIVE**  
**WATSONVILLE, CA 95076 (US)**

**ABSTRACT**

Methods for determining actuation of a capacitive button having at least three sensor electrode elements associated with at least three distinct sensor electrodes are described. In one embodiment, indicia from the at least three distinct sensor electrodes associated with the at least three sensor electrode elements comprising the capacitive button are received. At least three electrode values are generated from the indicia. The at least three electrode values are then utilized to determine actuation of the capacitive button.

(21) Appl. No.: **12/259,182**  
(22) Filed: **Oct. 27, 2008**



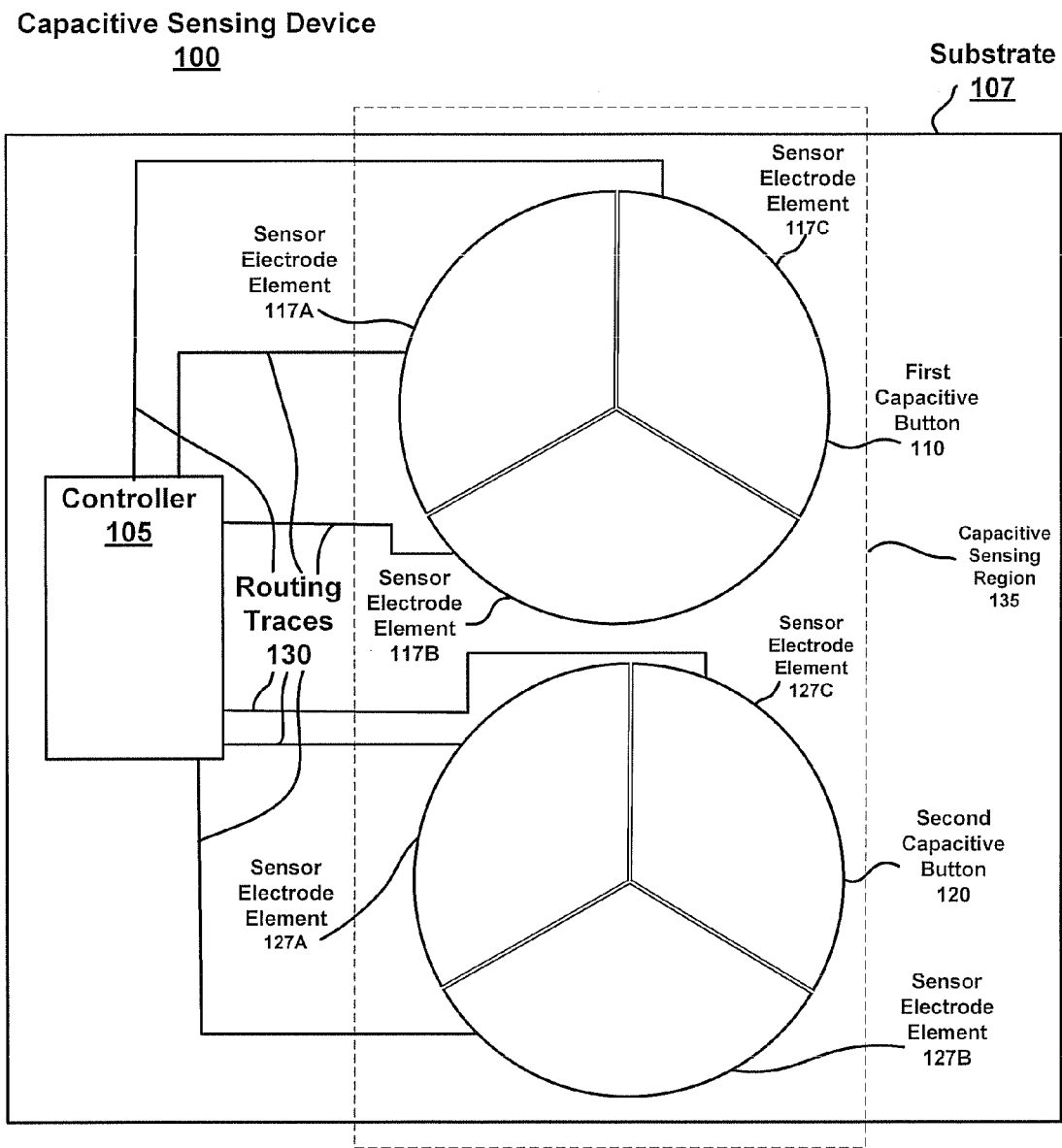


FIG. 1

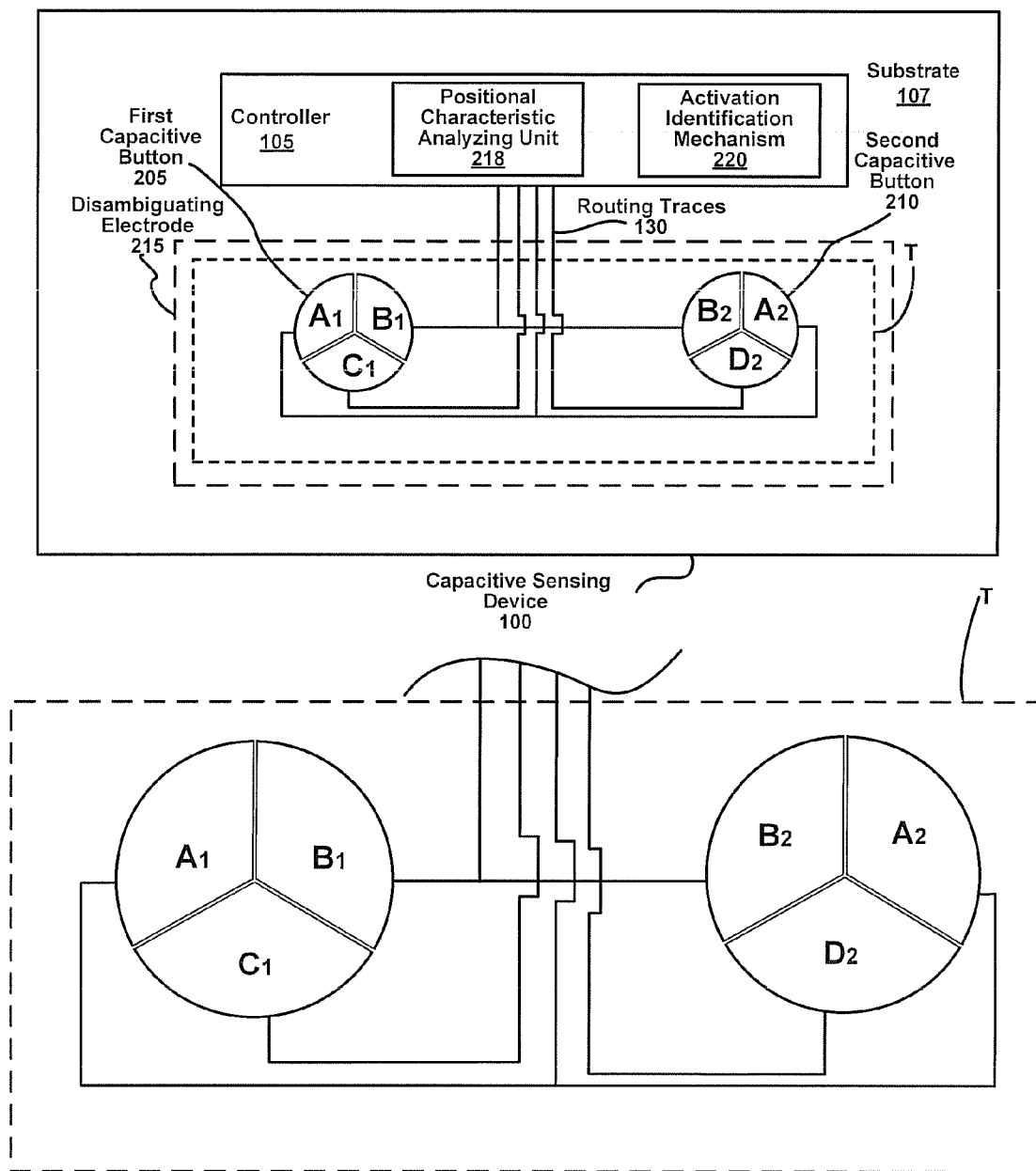


FIG. 2A

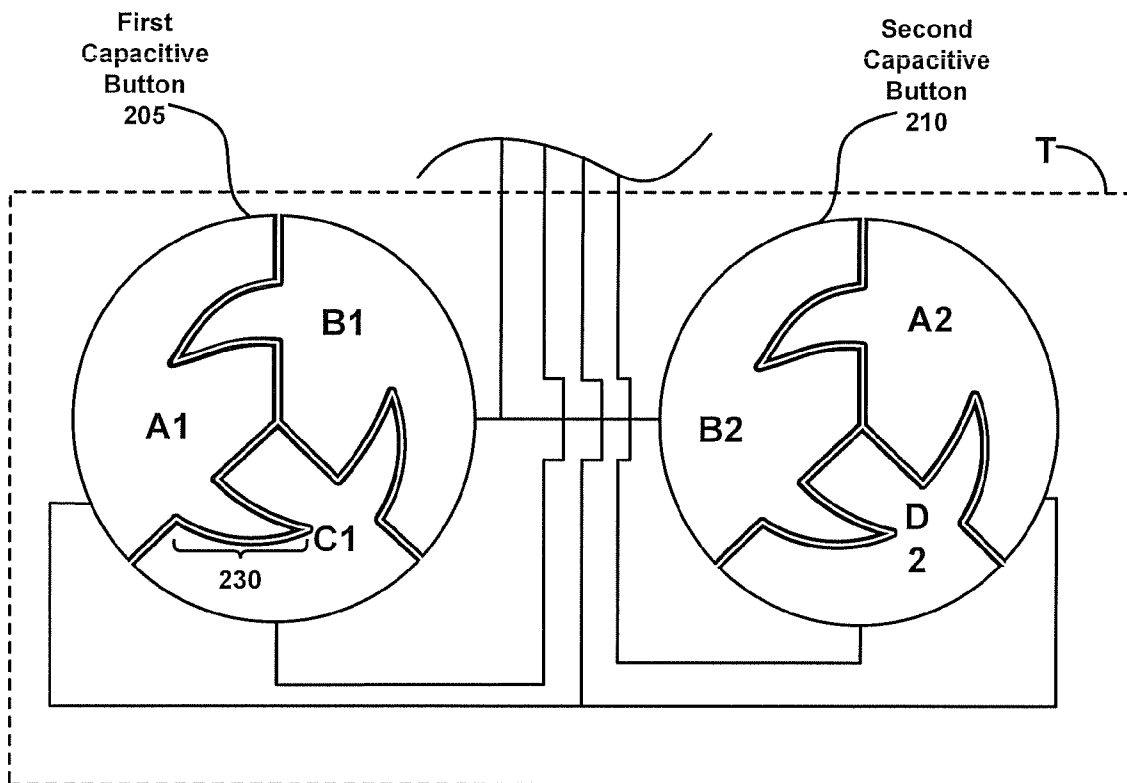


FIG. 2B

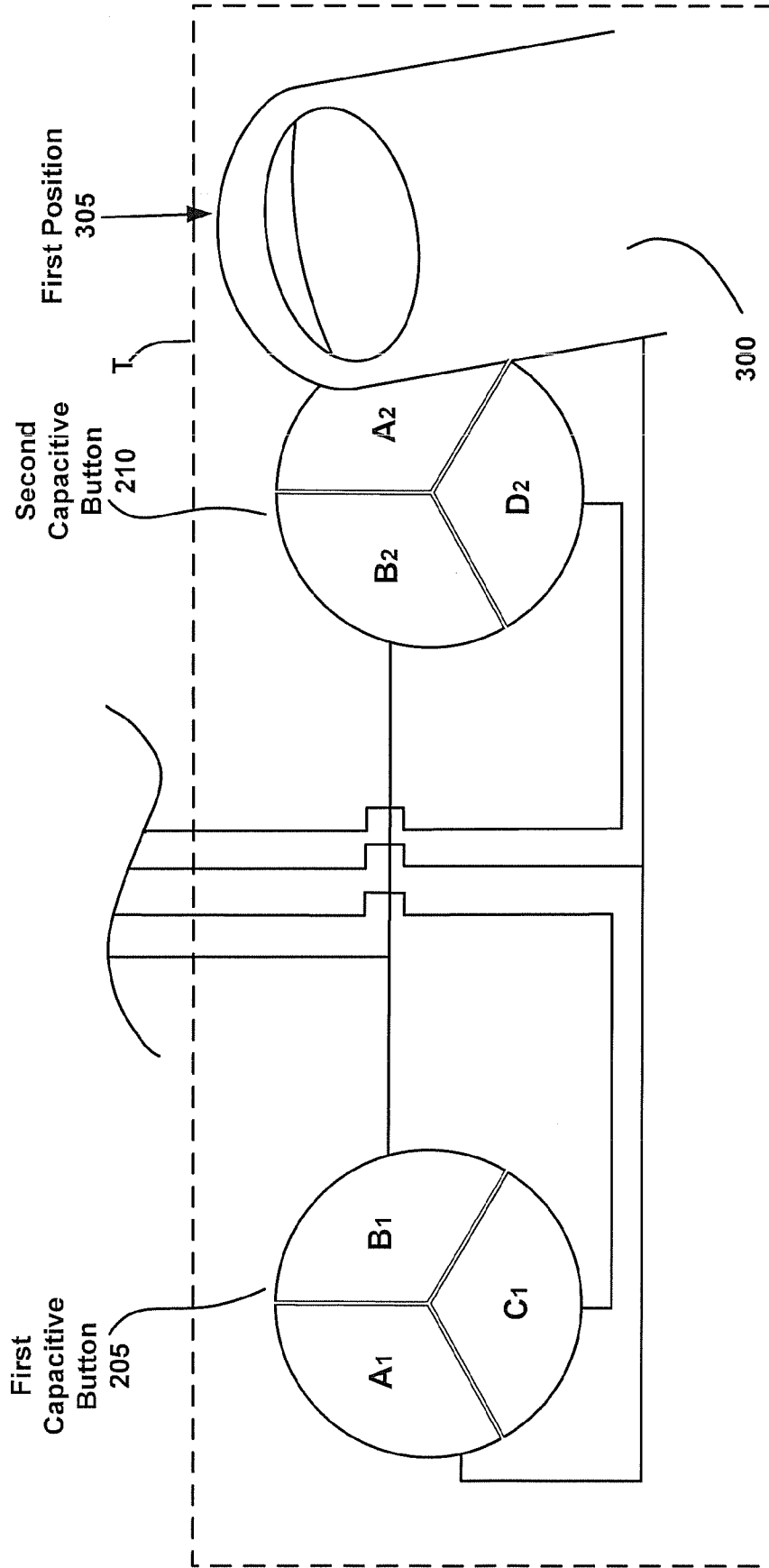


FIG. 3A

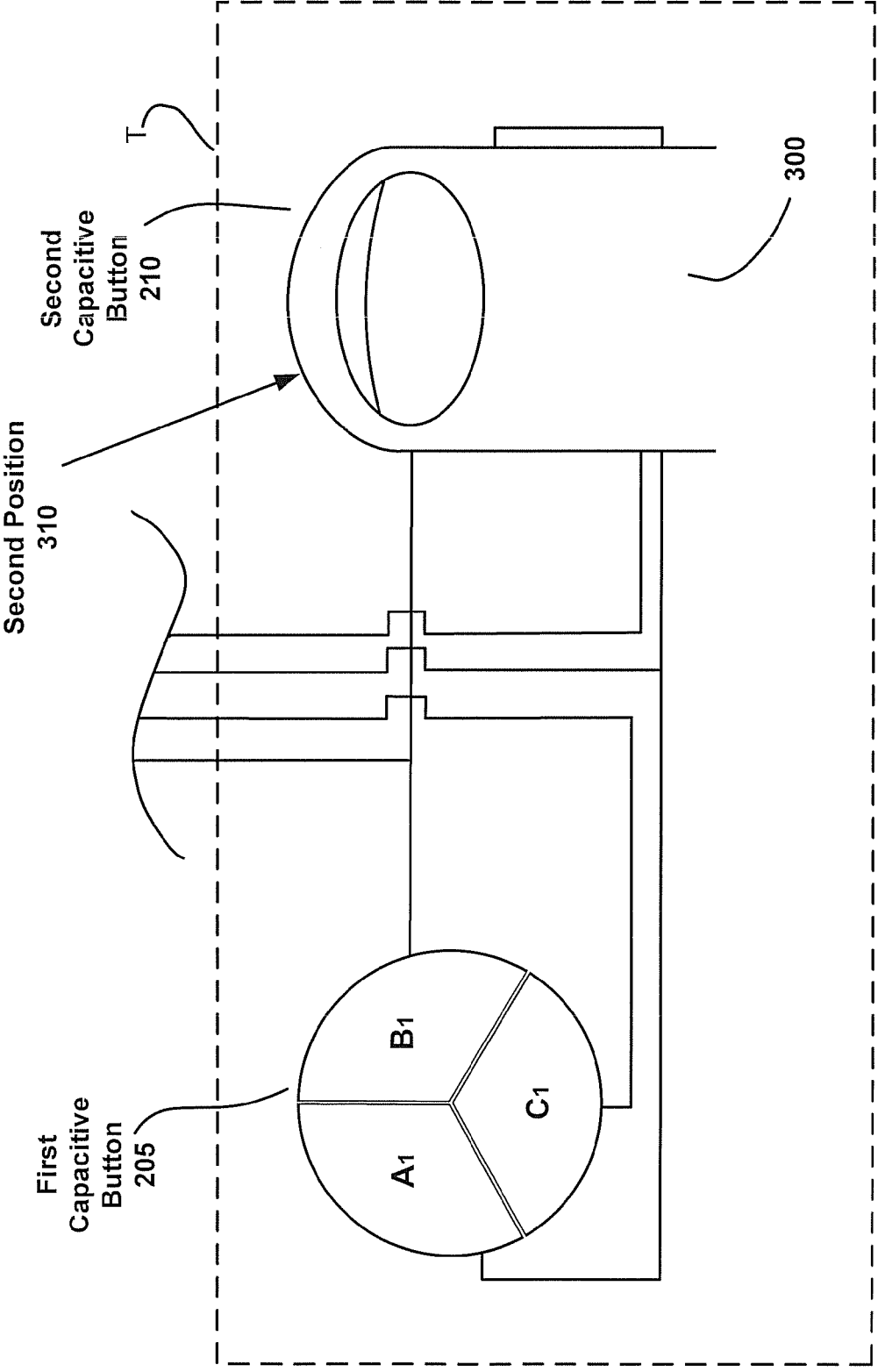


FIG. 3B

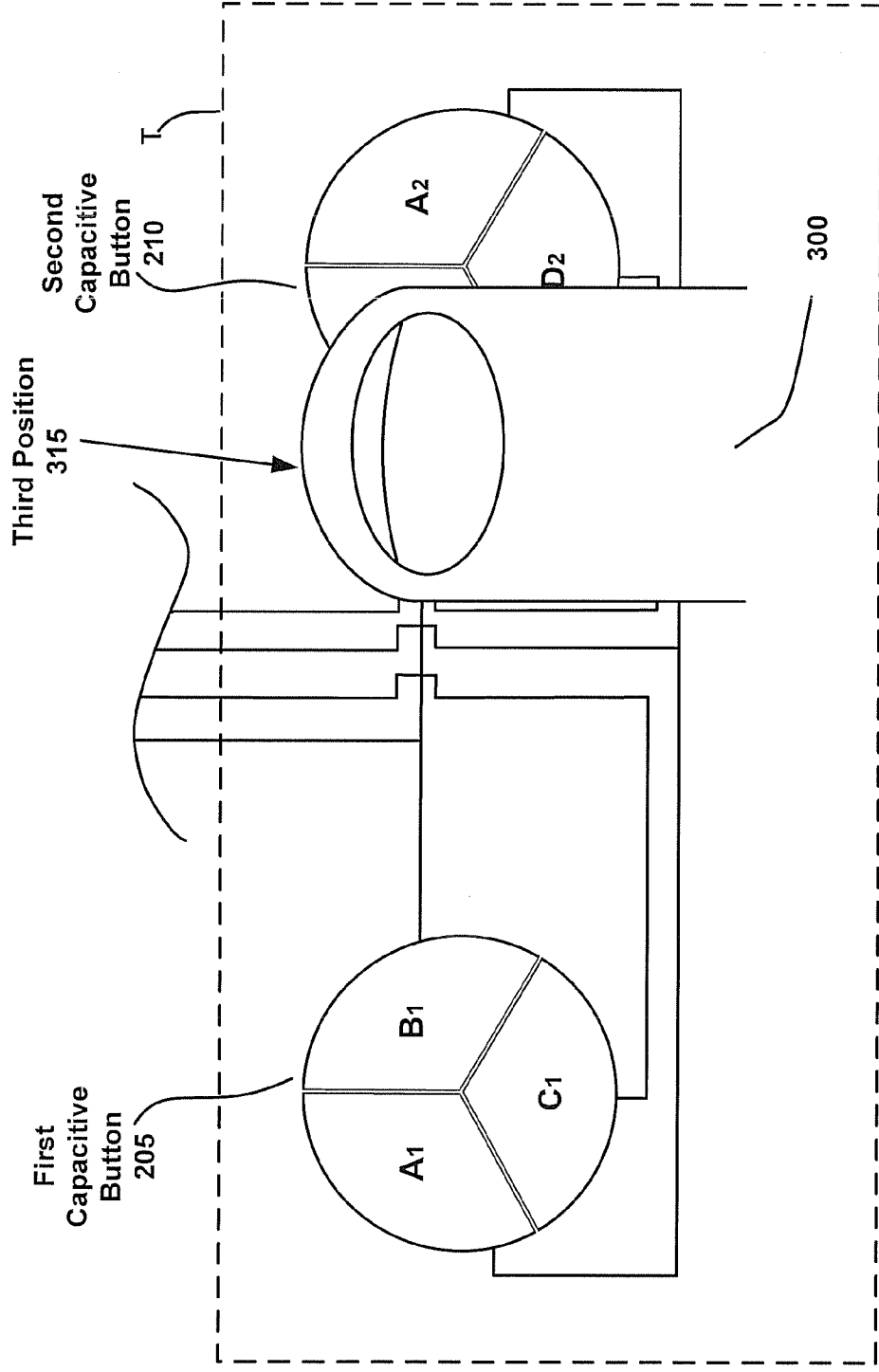


FIG. 3C

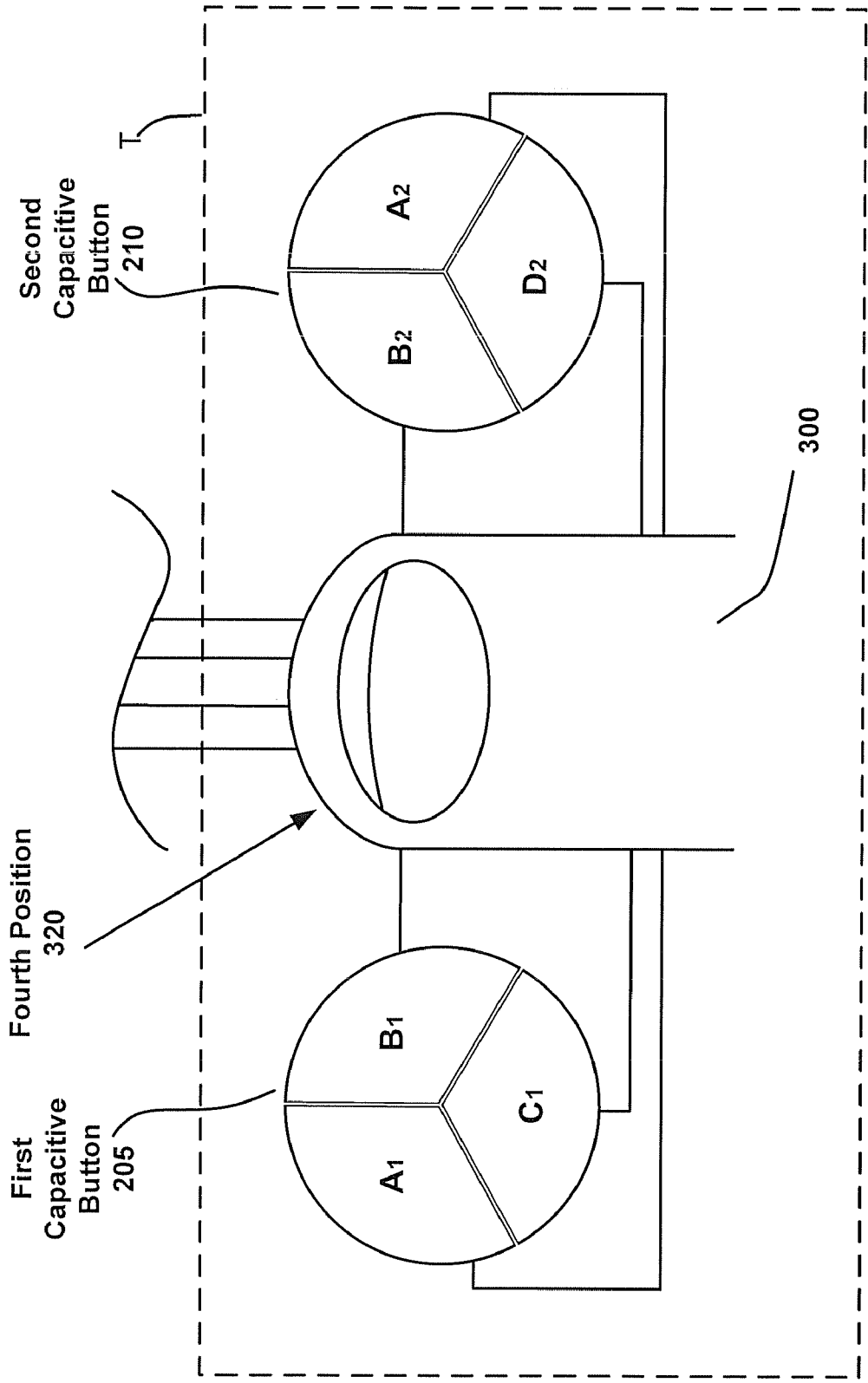


FIG. 3D



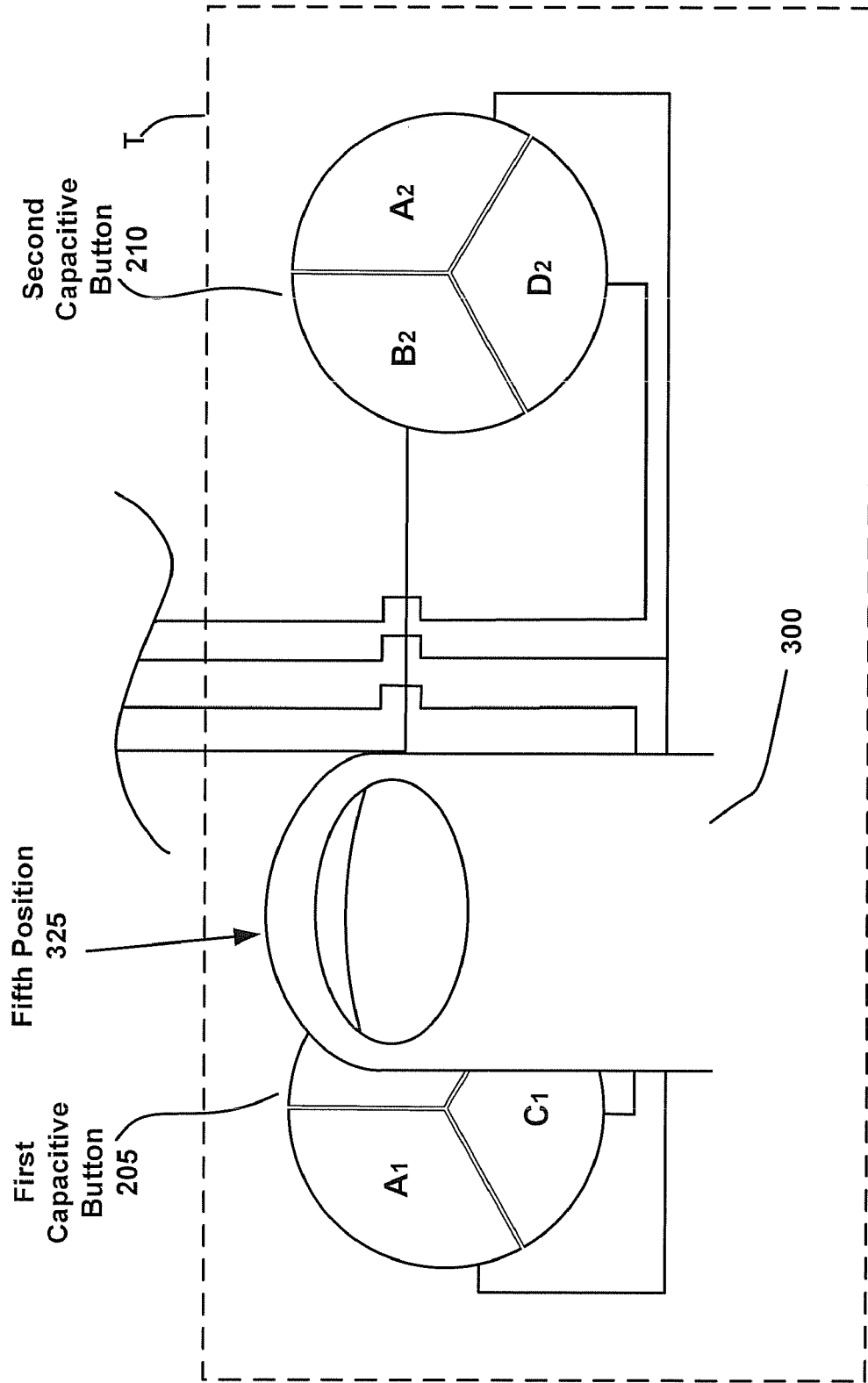


FIG. 3E

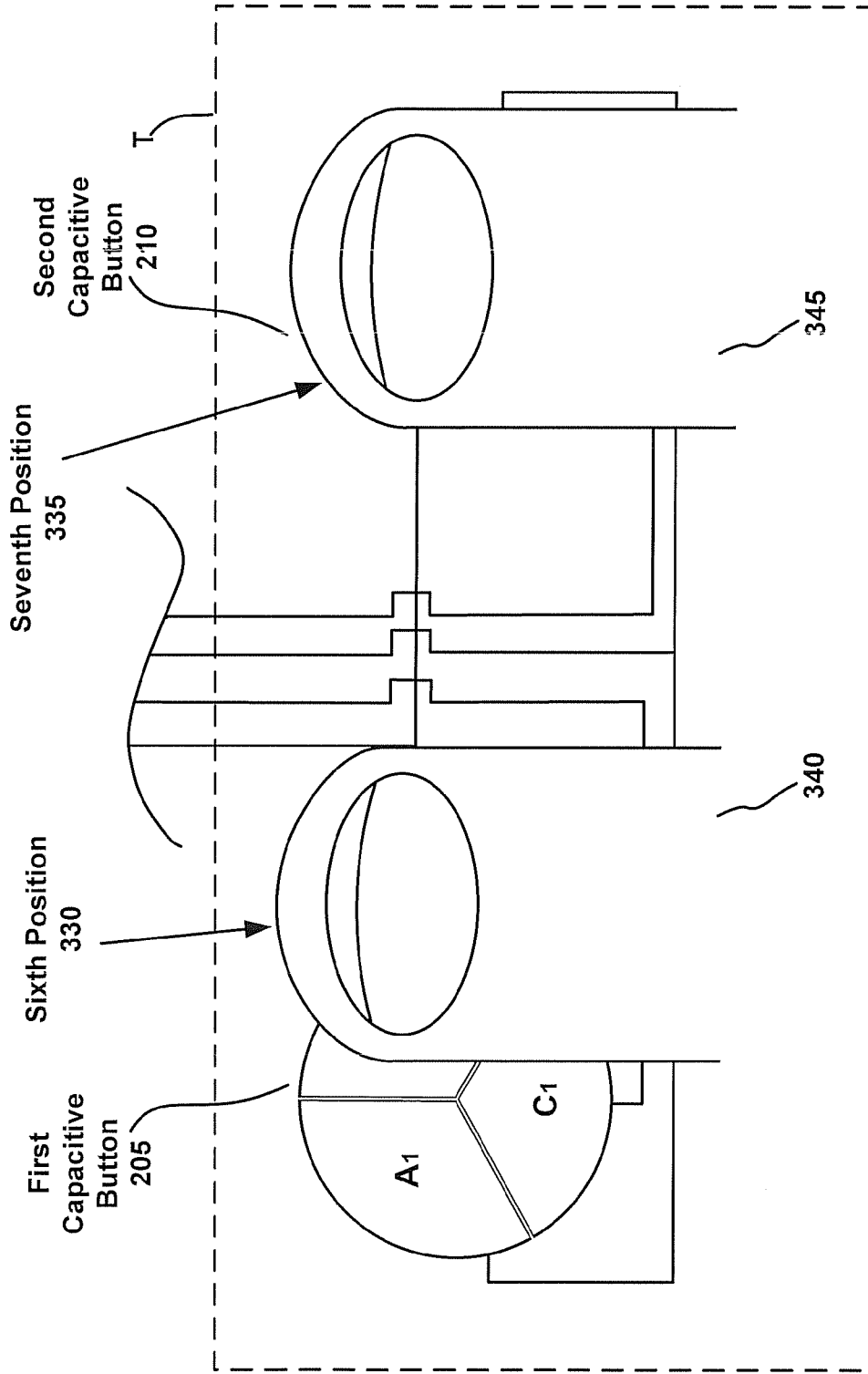
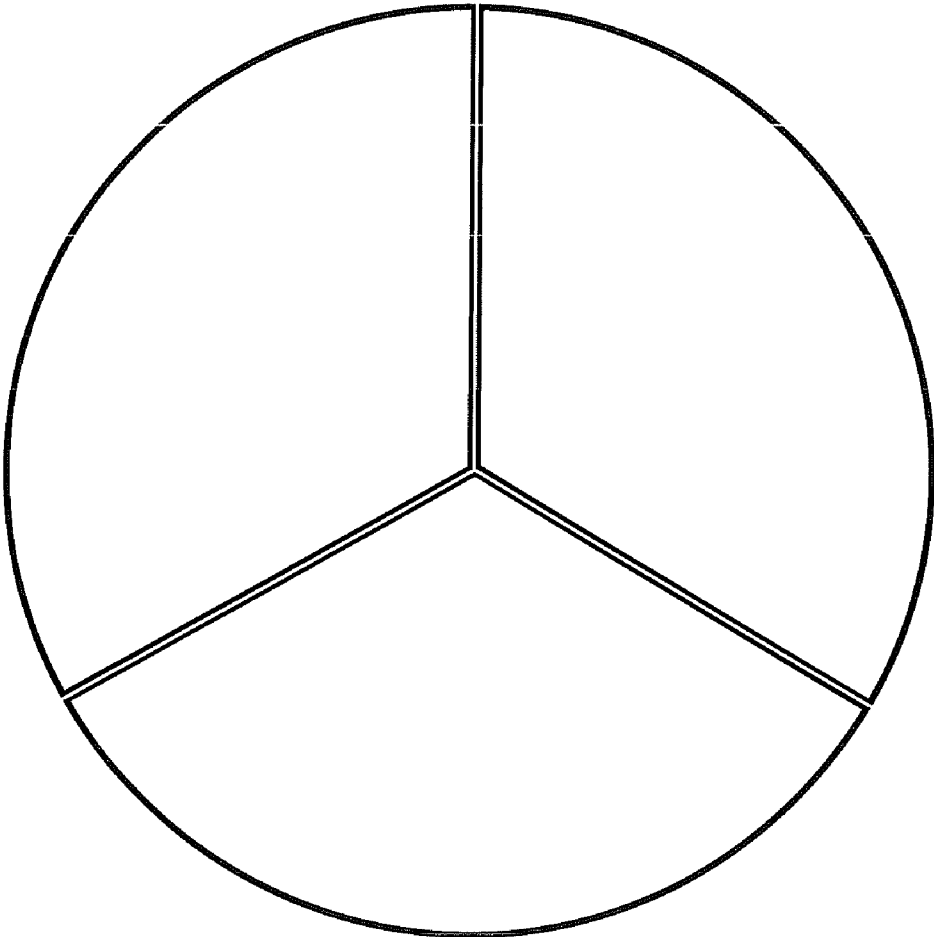
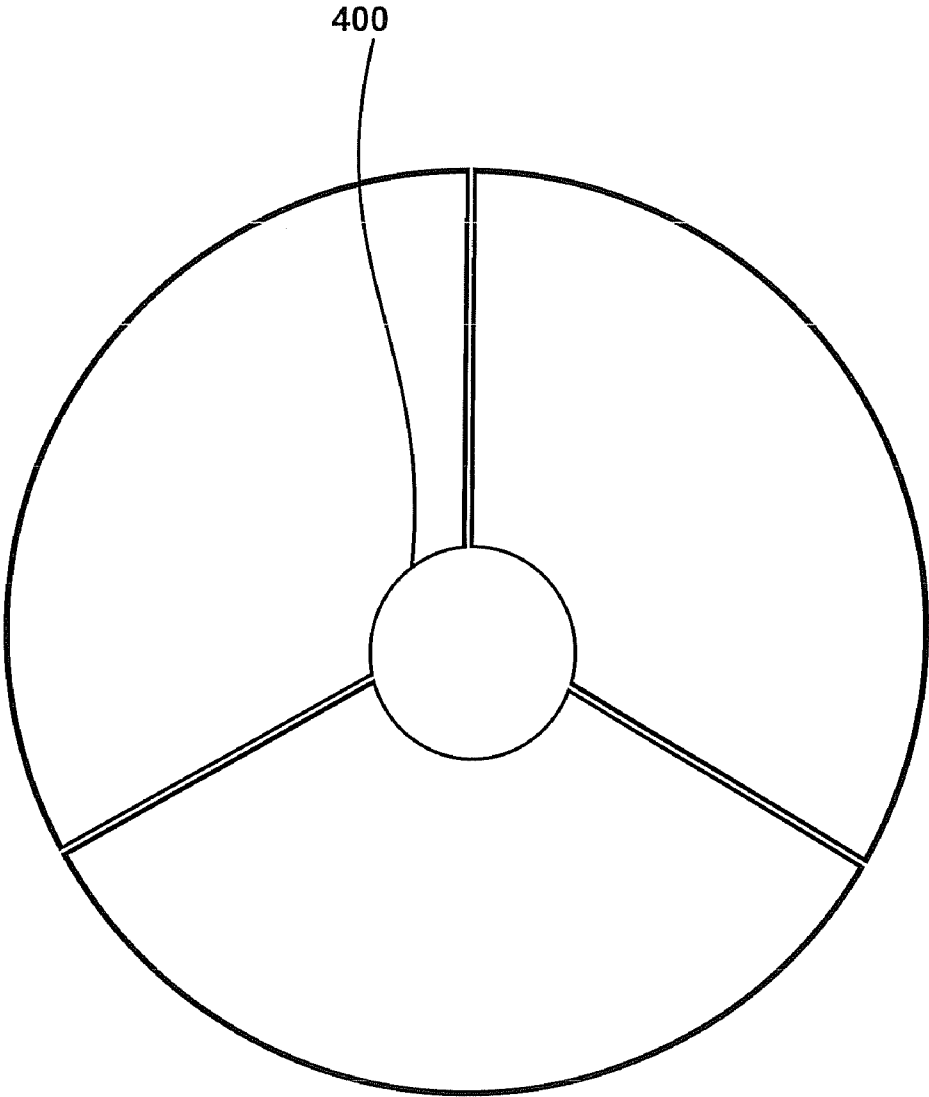


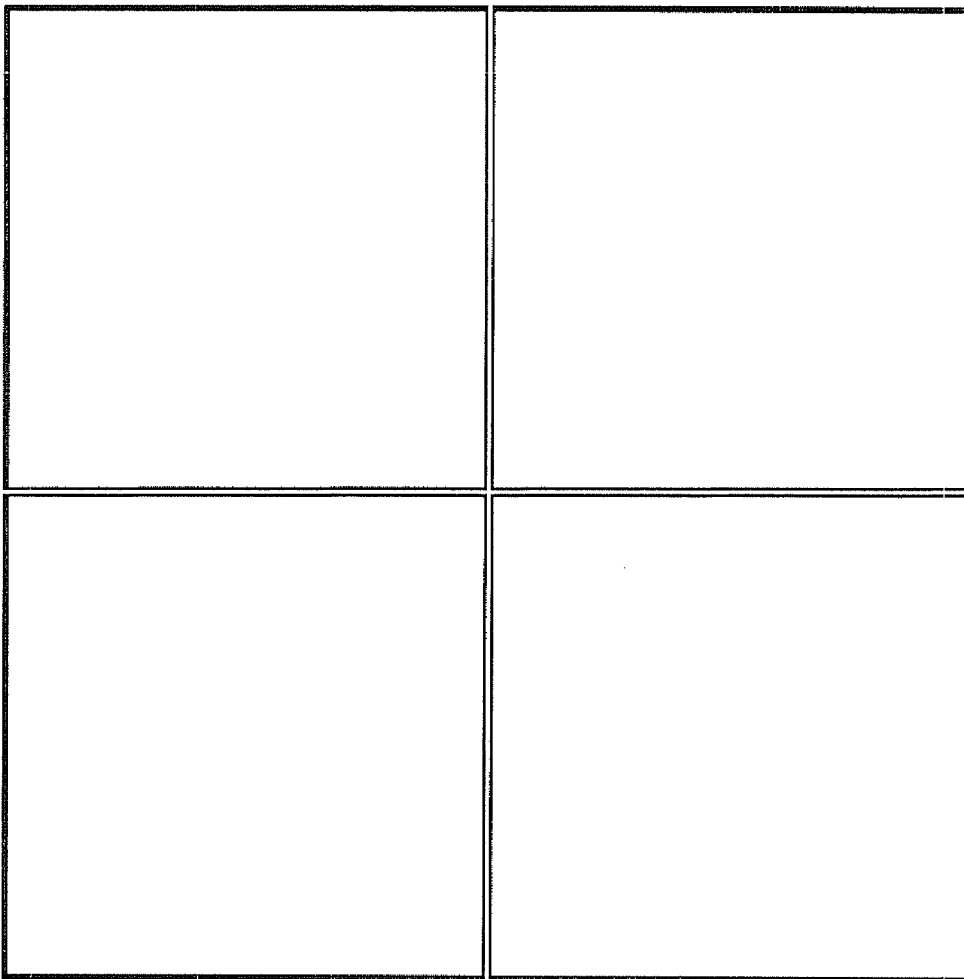
FIG. 3F



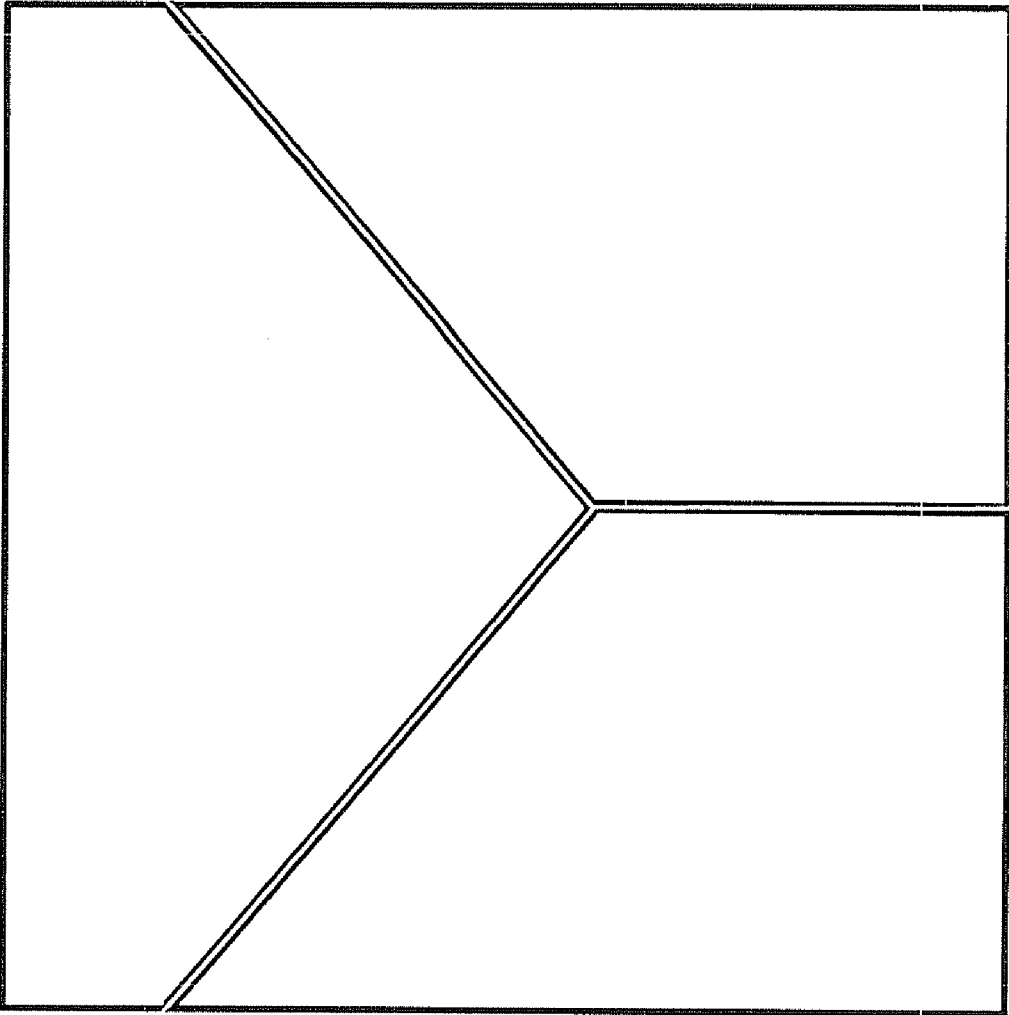
**FIG. 4A**



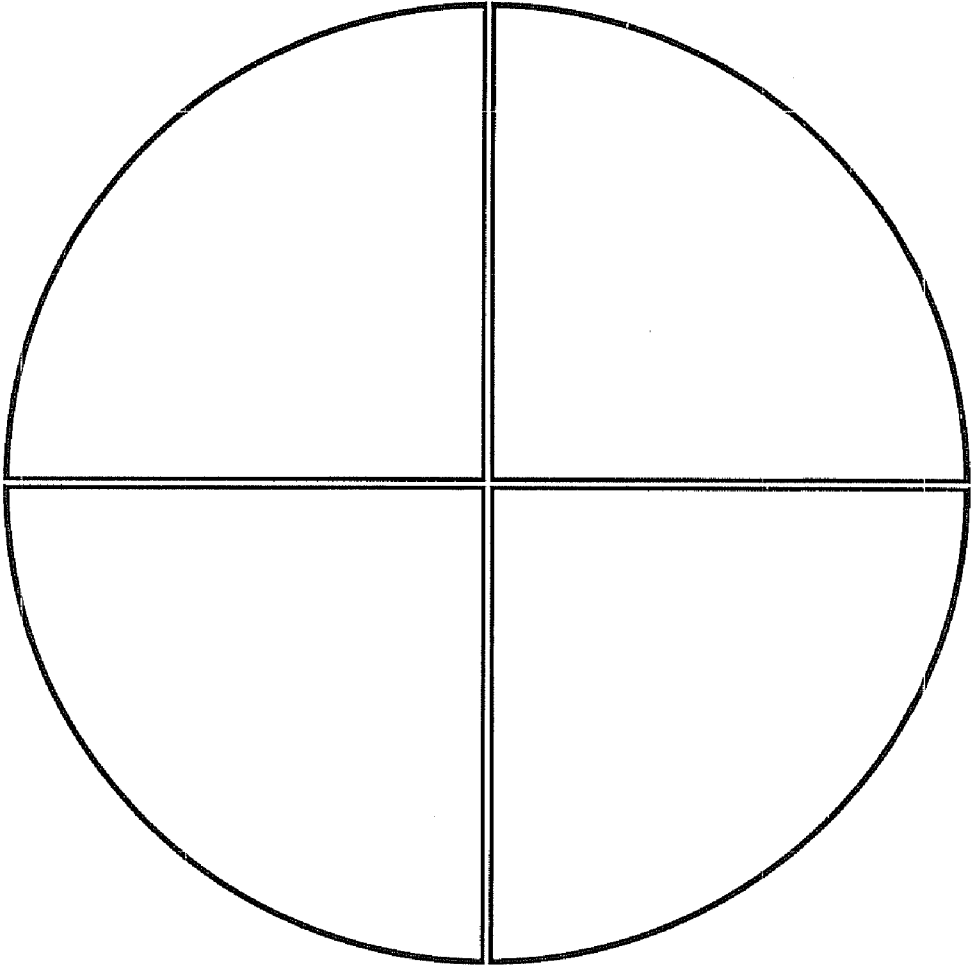
**FIG. 4B**



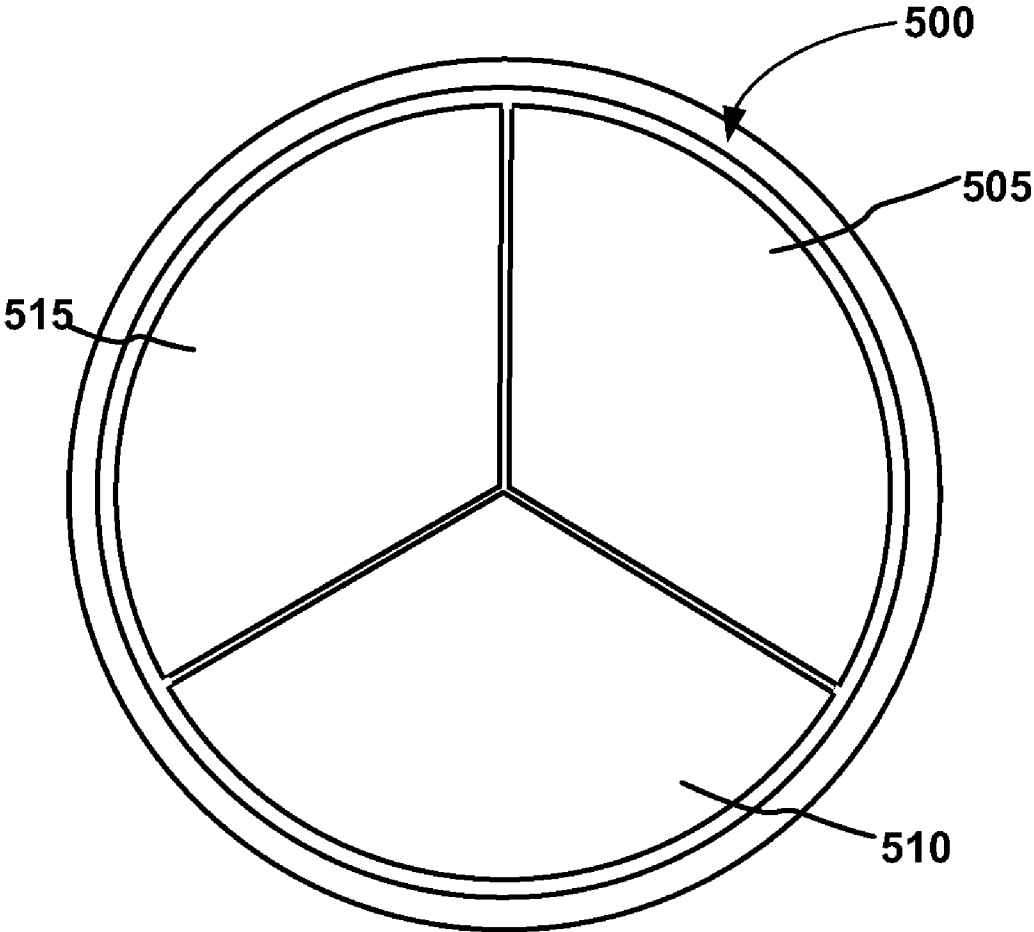
**FIG. 4C**



**FIG. 4D**

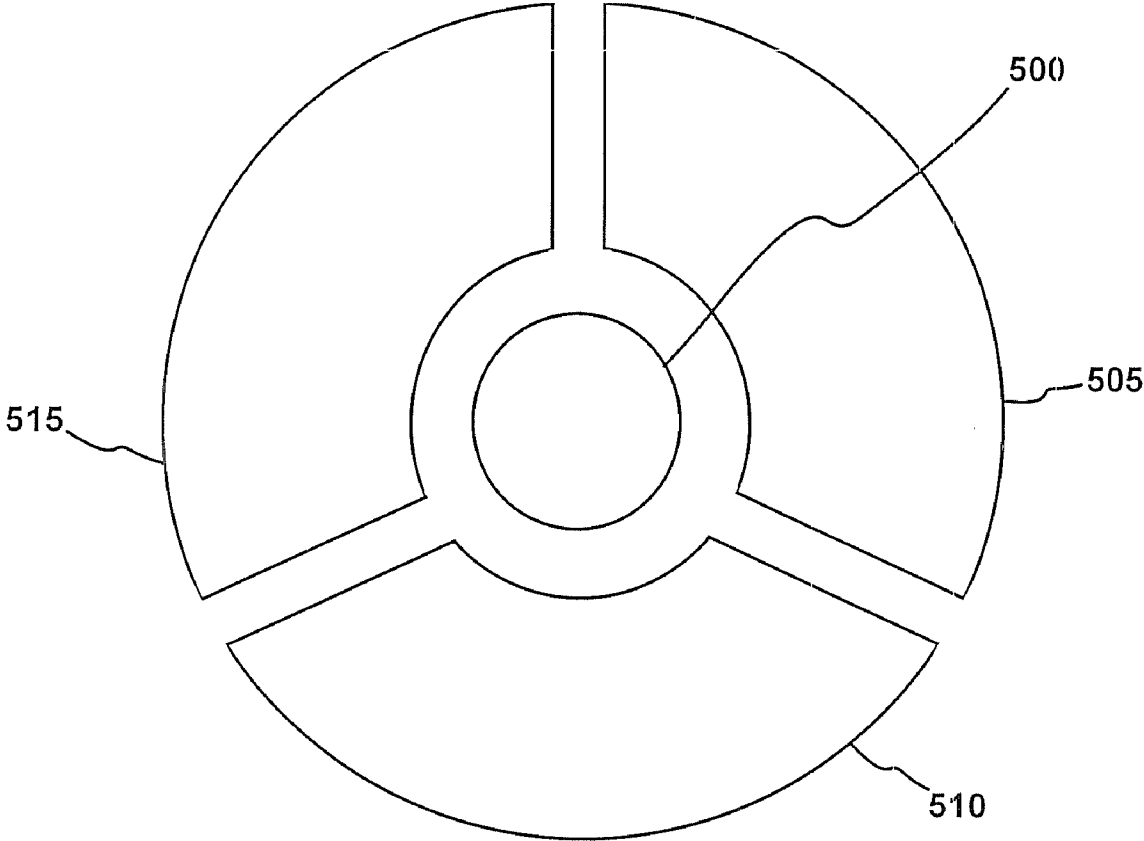


**FIG. 4E**



**FIG. 5A**





**FIG. 5B**

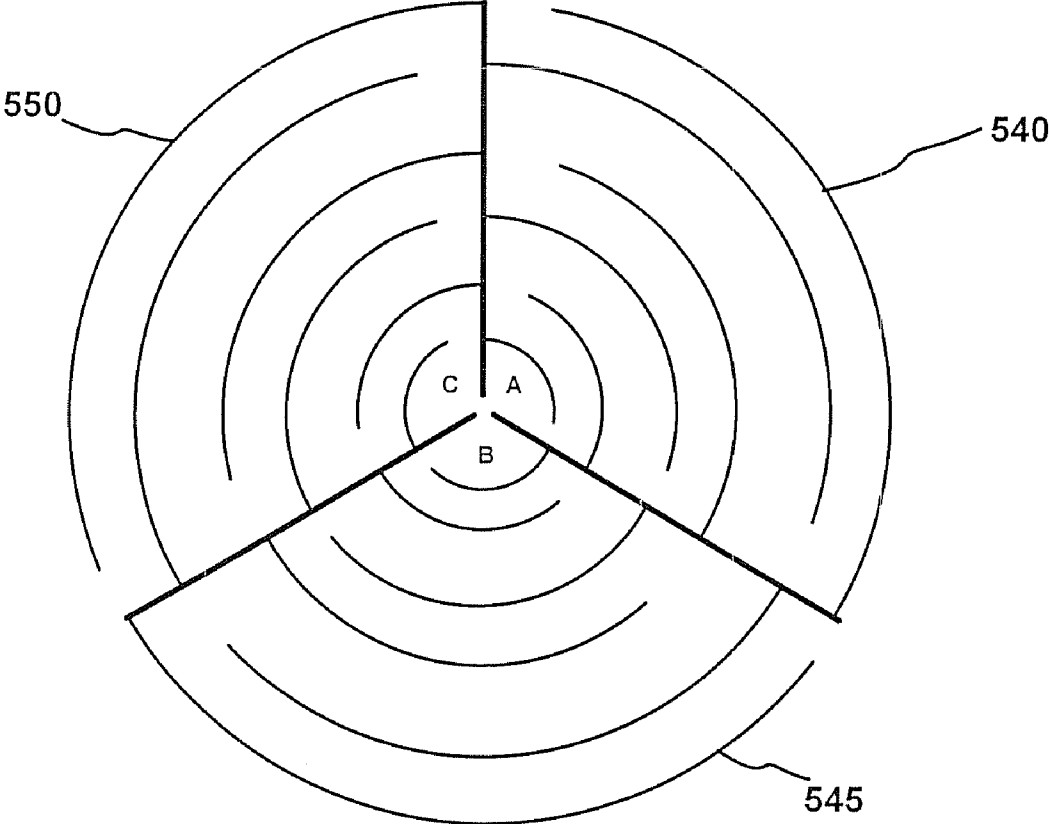


FIG. 5C

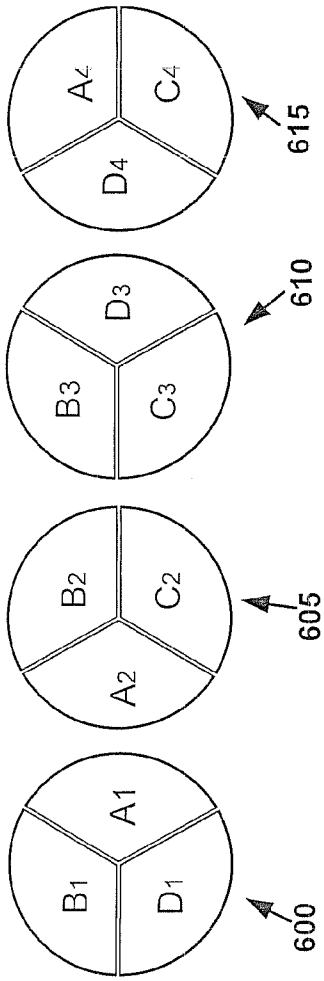


FIG. 6A

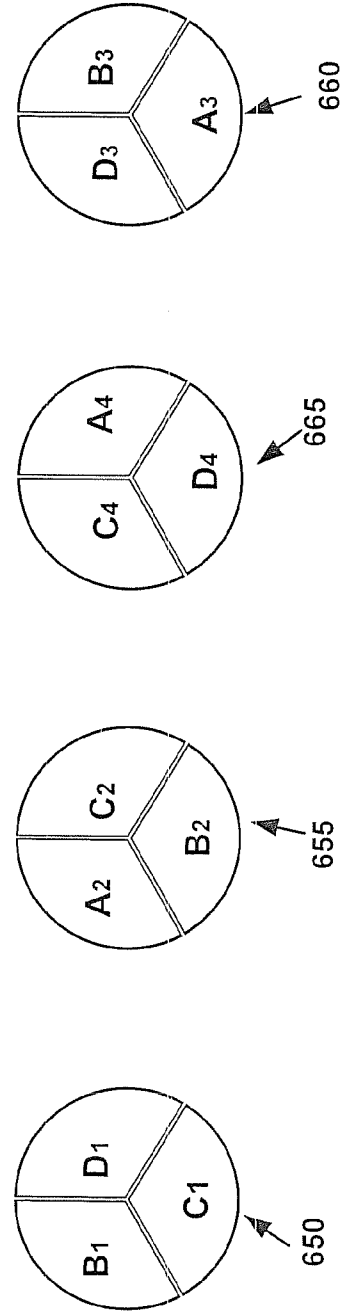


FIG. 6B

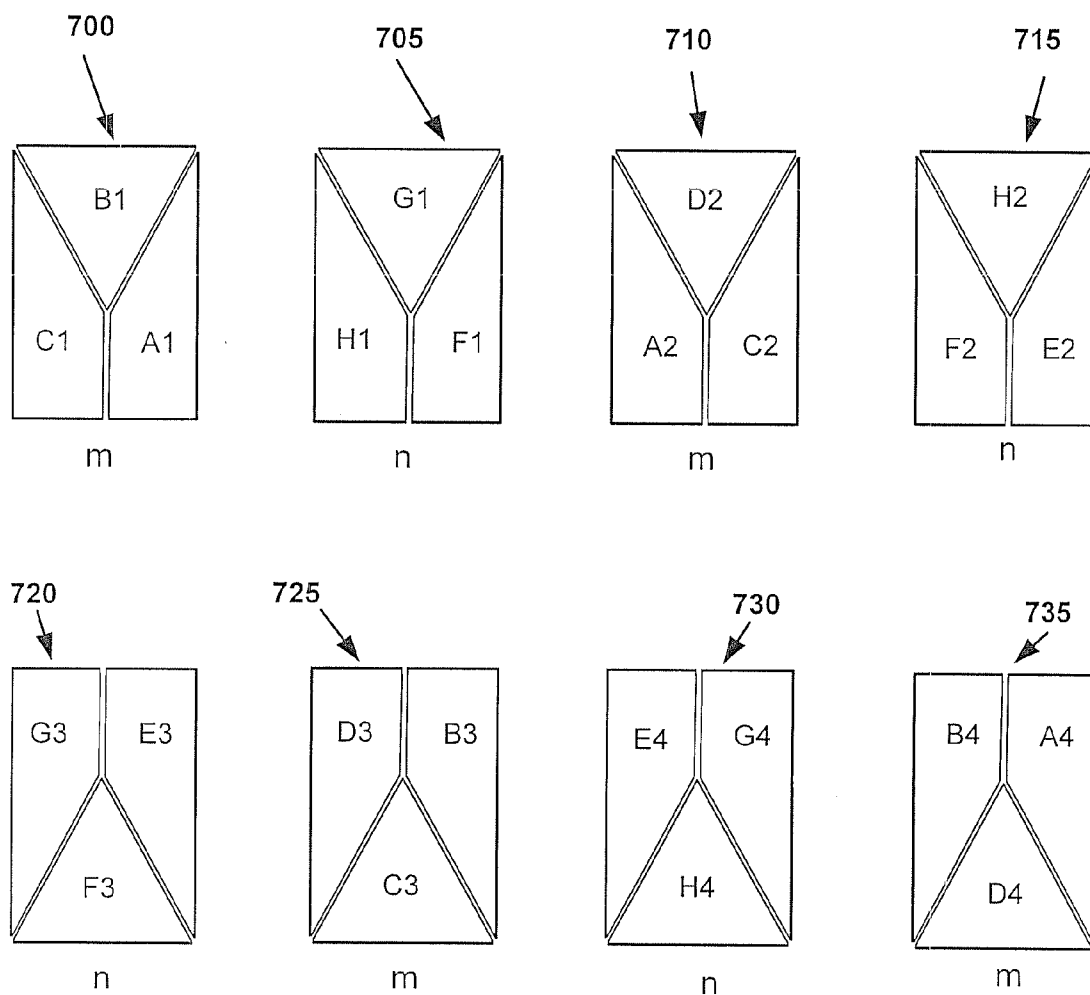


FIG. 7

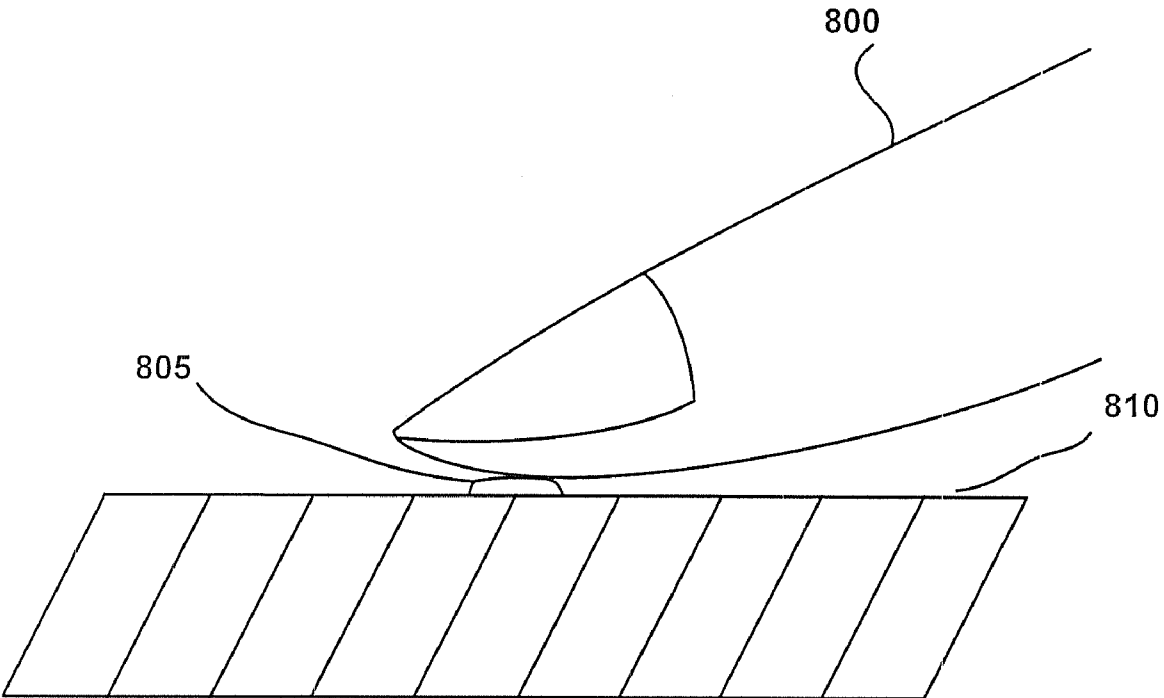
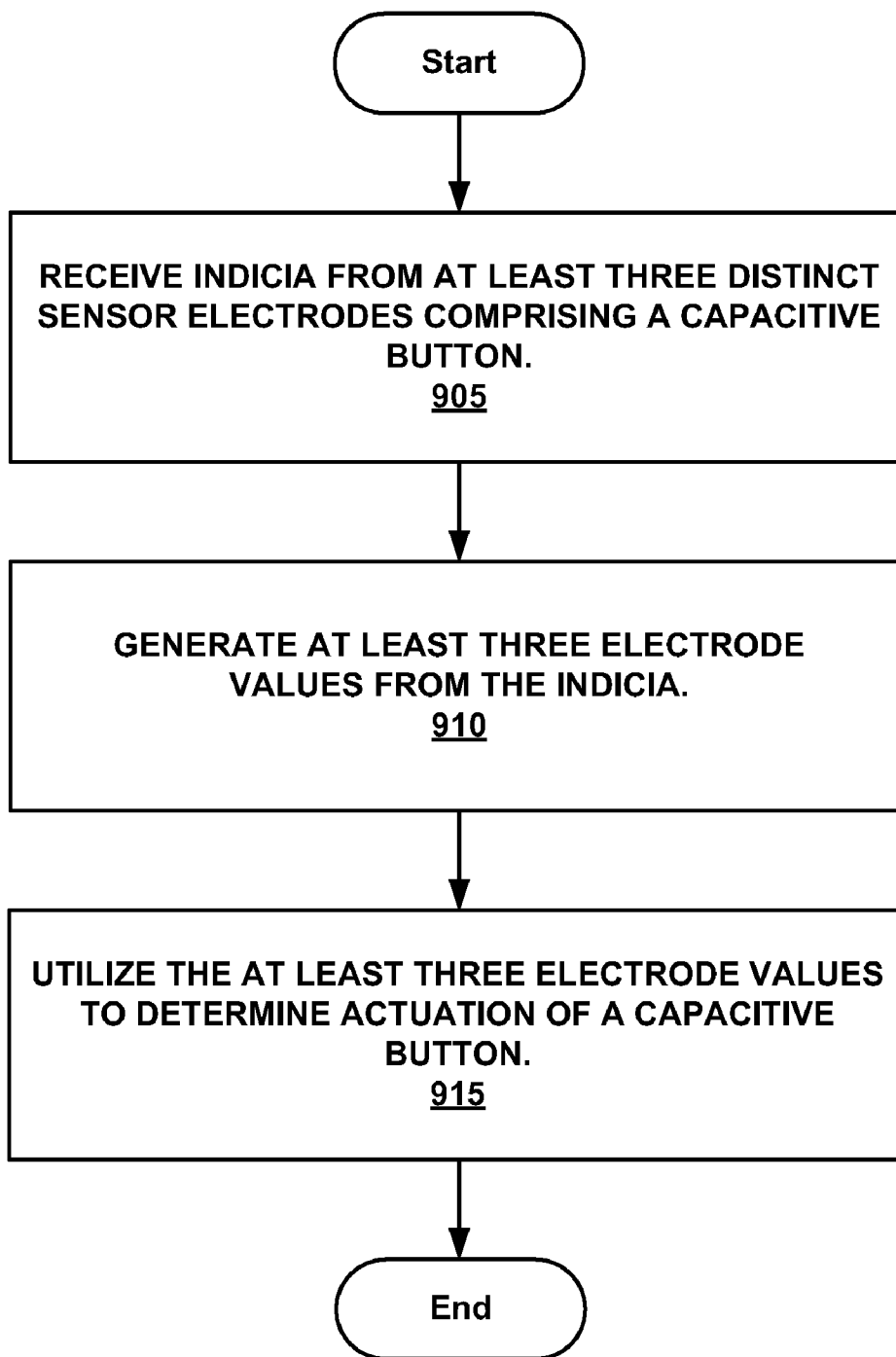


FIG. 8

**900**



**FIG. 9**

## MULTIPLE-SENSOR-ELECTRODE CAPACITIVE BUTTON

### RELATED U.S. APPLICATION

Provisional

[0001] This non-provisional application claims priority to the co-pending provisional patent application Ser. No. 61/000,784, Attorney Docket Number SYNA-20070619-A1, PRO, entitled "Capacitive Buttons," with filing date Oct. 28, 2007, and assigned to the assignee of the present invention, which is herein incorporated by reference in its entirety.

### BACKGROUND

[0002] Capacitive sensing devices are widely used in modern electronic devices. For example, capacitive sensing devices have been employed in music and other media players, cell phones and other communications devices, remote controls, personal digital assistants (PDAs), and the like. These capacitive sensing devices are often used for touch based navigation, selection, or other functions. These functions can be in response to one or more fingers, styli, other objects, or combination thereof providing input in the sensing regions of respective capacitive sensing devices.

[0003] However, there exist many limitations to the current state of technology with respect to capacitive sensing devices. As one example, limitations are known to be associated with capacitive button sensing systems.

### SUMMARY

[0004] In various embodiments, methods for determining actuation of a capacitive button having at least three sensor electrode elements associated with at least three distinct sensor electrodes are described. In one such embodiment, indicia from the at least three distinct sensor electrodes are received. At least three electrode values are generated from the indicia. The at least three electrode values are utilized to determine actuation of the capacitive button.

[0005] In various other embodiments, capacitive button apparatuses are described. One such apparatus includes a first capacitive button and a second capacitive button. The first capacitive button has a first set of sensor electrode elements configured to enable the generation of at least three electrode values for determining actuation of the first capacitive button. This first set of sensor electrode elements has at least three sensor electrode elements associated with distinct sensor electrodes. The second capacitive button has a second set of sensor electrode elements configured to enable the generation of at least three electrode values for determining actuation of the second capacitive button. This second set of sensor electrode elements has at least three sensor electrode elements associated with distinct sensor electrodes.

[0006] In order to improve capacitive button performance, such as by reducing false actuations, supporting non-button actuation input, and the like, capacitive buttons described herein uses multiple sensor electrodes.

### BRIEF DESCRIPTION OF THE DRAWINGS

[0007] The accompanying drawings, which are incorporated in and form a part of this specification, illustrate embodiments of the technology for multiple-sensor-electrode capacitive buttons and, together with the description, serve to explain principles discussed below:

[0008] FIG. 1 is a block diagram of an example capacitive button arrangement in accordance with embodiments of the present technology.

[0009] FIG. 2A is a block diagram of an example capacitive sensing device and an enlarged view of example components within the capacitive sensing device in accordance with embodiments of the present technology.

[0010] FIG. 2B is a block diagram of an enlarged view of example first and second capacitive buttons with interdigitated sensor electrode elements in accordance with embodiments of the present technology.

[0011] FIG. 3A is a block diagram of first and second capacitive buttons with an input object at a first position with respect to the capacitive buttons in accordance with embodiments of the present technology.

[0012] FIG. 3B is a block diagram of first and second capacitive buttons with an input object at a second position with respect to the capacitive buttons in accordance with embodiments of the present technology.

[0013] FIG. 3C is a block diagram of first and second capacitive buttons with an input object at a third position with respect to the capacitive buttons in accordance with embodiments of the present technology.

[0014] FIG. 3D is a block diagram of first and second capacitive buttons with an input object at a fourth position with respect to the capacitive buttons in accordance with embodiments of the present technology.

[0015] FIG. 3E is a block diagram of first and second capacitive buttons with an input object at a fifth position with respect to the capacitive buttons in accordance with embodiments of the present technology.

[0016] FIG. 3F is a block diagram of first and second capacitive buttons with two input objects concurrently in the sensing region of the capacitive buttons in accordance with embodiments of the present technology.

[0017] FIG. 4A is a diagram of a circular capacitive button with three sensor electrode elements in accordance with embodiments of the present technology.

[0018] FIG. 4B is a diagram of an annular capacitive button with three sensor electrode elements surrounding an aperture in accordance with embodiments of the present technology.

[0019] FIG. 4C is a diagram of a square-shaped capacitive button with four sensor electrode elements in accordance with embodiments of the present technology.

[0020] FIG. 4D is a diagram of a rectangular capacitive button with three sensor electrode elements in accordance with embodiments of the present technology.

[0021] FIG. 4E is a diagram of a circular capacitive button with four sensor electrode elements in accordance with embodiments of the present technology.

[0022] FIG. 5A is a diagram of a capacitive button with an emitter sensor electrode element surrounding sensor electrode elements in accordance with embodiments of the present technology.

[0023] FIG. 5B is a diagram of a capacitive button with a separate emitter sensor electrode element surrounded by sensor electrode elements in accordance with embodiments of the present technology.

[0024] FIG. 5C is a diagram of a capacitive button with sensor electrode elements capable of emitting as well as sensing signals in accordance with embodiments of the present technology.

**[0025]** FIG. 6A is a diagram of four circular capacitive buttons sharing four sensor electrodes in accordance with embodiments of the present technology.

**[0026]** FIG. 6B is a diagram of four circular capacitive buttons sharing four sensor electrodes in accordance with embodiments of the present technology.

**[0027]** FIG. 7 is a block diagram of an example arrangement of capacitive buttons in accordance with embodiments of the present technology.

**[0028]** FIG. 8 is a cross-sectional view of a tactile feature in accordance with embodiments of the present technology.

**[0029]** FIG. 9 is a flowchart of an example method for determining actuation of a capacitive button in accordance with embodiments of the present technology.

**[0030]** The drawings referred to in this description should not be understood as being drawn to scale unless specifically noted.

#### DESCRIPTION OF EMBODIMENTS

**[0031]** Reference will now be made in detail to embodiments of the present technology, examples of which are illustrated in the accompanying drawings. While the present technology will be described in conjunction with embodiments, it will be understood that the descriptions are not intended to limit the present technology to these embodiments. On the contrary, the descriptions are intended to cover alternatives, modifications and equivalents, which may be included within the spirit and scope as defined by the appended claims. Furthermore, in the following detailed description, numerous specific details are set forth in order to provide a thorough understanding of embodiments of the present technology. However, one of ordinary skill in the art will understand that embodiments of the present technology may be practiced without these specific details. In other instances, well known methods, procedures, components, and circuits have not been described in detail as not to unnecessarily obscure aspects of the present technology.

#### Overview of Discussion

**[0032]** Embodiments in accordance with the present technology pertain to capacitive buttons and their usage. In one embodiment in accordance with the present technology, the capacitive sensing devices described herein improve distinguishing between input intended to actuate a capacitive button and input not intended to actuate a capacitive button. Indicia received from sensor electrodes associated with a capacitive button are used to determine electrode values. These electrode values are utilized to determine the actuation status of the capacitive button. Positional characteristics about one or more input objects may or may not be determined in support of gauging the actuation status of a capacitive button. The positional characteristics determined can include a myriad of diverse measurements related to the object(s) in a capacitive sensing region of the capacitive button, as discussed further below. Possible input objects include fingers, styli, and other input objects capable of conveying user input. The term “finger” is used herein to refer to any digit on a hand, including a thumb. The term “actuation” is used herein to refer to turning a capacitive button ON. Conversely, the term “activation” is used herein to refer to a sufficient user interaction that has occurred with respect to a sensor electrode.

**[0033]** In various embodiments, a capacitive button arrangement includes a plurality of multiple-sensor-electrode capacitive buttons (“MSE capacitive buttons”). Each MSE capacitive button is comprised of multiple sensor electrode elements belonging to distinct sensor electrodes. Where it may otherwise be unclear, “MSE capacitive button” is used in this document to distinguish from capacitive buttons that do not use a multiple-sensor-electrode approach. For example, a single capacitive button arrangement may include capacitive buttons of different types, including any combination of capacitive buttons having only a single sensor electrode element, exactly two sensor electrode elements, three sensor electrode elements, or any number of sensor electrode elements.

**[0034]** A sensor electrode in a capacitive button arrangement may have one or more sensor electrode elements. Thus, a single sensor electrode may include sensor electrode elements in multiple capacitive buttons, and thus be shared among those multiple capacitive buttons. A sensor electrode element that forms a portion of a sensor electrode is considered to belong to that sensor electrode, and is also considered to be associated with that sensor electrode. A set of sensor electrode elements including an element forming a portion of a sensor electrode is considered to be associated with that sensor electrode. Since the sensor electrode elements and sensor electrodes are used for capacitance sensing, they can also be termed “sensor electrode elements” and “sensor electrodes,” respectively.

**[0035]** In various embodiments, each MSE capacitive button of a capacitive button arrangement is comprised of a set of sensor electrode elements associated with a plurality of sensor electrodes. Each of the sets of sensor electrode elements has at least three elements associated with distinct ones of the plurality of sensor electrodes. That is, each set of sensor electrode elements includes separate elements that form portions of at least three different sensor electrodes.

**[0036]** During operation, the plurality of sensor electrodes provides indicia that are received by a controller. The indicia reflect user input in the sensing region. Since user input in the sensing region affects the electric field surrounding the sensor electrodes, the indicia can be electric signals that change with the electric field surrounding the sensor electrodes. For example, the indicia may include voltages, currents, charges, frequencies, time constants, or any other items that varies with changes in the capacitive coupling to the sensor electrodes.

**[0037]** The controller utilizes the received indicia to generate at least three electrode values for each MSE capacitive button. Since one sensor electrode may have sensor electrode elements in multiple capacitive buttons, one electrode value may be associated with multiple capacitive buttons. Thus, the total number of electrode values generated by the controller may be less than three times the number of capacitive buttons, although that is not required. The electrode values generated by the controller may be linearly or non-linearly related to the capacitive coupling of the sensor electrodes (e.g. some representation of the capacitive coupling that is proportional to the change in capacitance, or that is proportional to a reciprocal of the change in capacitance). Since these electrode values are derived from indicia received from sensor electrodes, they can also be termed “sensor electrode values.”

**[0038]** Oftentimes, the indicia and/or the electrode values is/are conditioned or filtered by the controller. The controller



may do this by averaging, by subtracting baselines, by particular weighting functions determined by the capacitive button design, and the like.

**[0039]** The controller utilizes the electrode values to recognize user input, such as to determine whether or not a capacitive button is actuated. As discussed above, some embodiments determine positional characteristics about the input objects as part of the process for gauging the actuation status of a capacitive button while other embodiments do not. That is, embodiments of the present technology may calculate none, some, or all of the derivable positional characteristics.

**[0040]** Positional characteristics encompass a myriad of different information that may be derived about the interaction of input devices with MSE capacitive buttons. Many of the positional characteristics represent substantially independent spatial measurements of the user input within the sensing region. Some example positional characteristics represent estimates of the locations of inputs along one or more dimensions, at an instance in time or over a span of time. For example, the position of an input may be determined with respect to a 2D plane defined by the touch pad (e.g. as X and Y, as r and  $\theta$ , or as any other appropriate set of coordinates).

**[0041]** Other examples of positional characteristics represent estimates of the amount of capacitive coupling to an input (e.g., as Z); the amount of capacitive coupling changes with the distance and size of the input, signals coupled into an input object, and the like. Additional examples of positional characteristics may include various time derivatives and integrals of other positional characteristics (e.g. of X, Y, or Z). Further examples of positional characteristics include averages, ratios, magnitudes, and combinations of any of the foregoing.

**[0042]** An MSE capacitive button may support any type of user interface. For example, they may be used with any of the devices which can be supported by non-MSE capacitive buttons. Examples include, and are not limited to: input devices such as keypads, keyboards, and remote controls; media devices such as cameras, video recorders or players, music recorders or players; communications or organizational devices such as personal digital assistants (PDAs), cell phones, GPS systems; and the like.

**[0043]** MSE capacitive buttons may also be indicated to the user in various ways. For example, any number of shapes and sizes of indicators may be placed between the sensor electrode elements and the user. This may include primarily visual indicators such as painted lines or lighted cutouts. This may also include primarily tactile indicators such as bumps, ridges, depressions, and the like. Additionally, according to some embodiments of the present technology, capacitive buttons are well suited to effecting a haptic response by providing information about anticipated or current button actuation directly or indirectly to a controller of a haptic feedback system.

**[0044]** The following discussion will begin with a detailed description focused on aspects of the structure in accordance with the present technology. This discussion will then be followed by a detailed description focused on aspects of the operation in accordance with the present technology.

#### Example Capacitive Button Arrangement

**[0045]** FIG. 1 is a block diagram of an example capacitive sensing device 100 in accordance with embodiments of the present technology. Capacitive sensing device 100 comprises a plurality of noncontiguous MSE capacitive buttons (two are

shown, as first capacitive button 110 and second capacitive button 120) disposed on substrate 107 and capable of sensing objects within capacitive sensing region 135. First capacitive button 110, second capacitive button 120, and controller 105 are all shown disposed on the same substrate 107 in FIG. 1; disposing them on any number of separate substrates in other embodiments is possible and contemplated. The substrates can be rigid or flexible.

**[0046]** Capacitive sensing region 135 is a three-dimensional region extending from the capacitive buttons. Input objects in sensing region 135 may interact with the capacitive sensing device 100. The size and shape of capacitive sensing region 135 is defined by the mechanical and electrical characteristics of the capacitive sensing device 100 (e.g. shapes and sizes of surrounding materials, layout of electrodes and routing lines), the circuitry and algorithms of controller 105, the performance desired, and the like.

**[0047]** The MSE capacitive buttons of capacitive sensing device 100 are comprised of different sets of sensor electrode elements, where each set of sensor electrode elements have at least three members that are associated with different sensor electrodes. In FIG. 1, capacitive buttons 110 and 120 are each comprised of a set of three sensor electrode elements exactly: first capacitive button 110 has a first set including sensor electrode elements 117A-117C, and a second capacitive button 120 has a set including sensor electrode elements 127A-127C.

**[0048]** FIG. 1 shows a capacitive button arrangement in which sensor electrodes are not shared between MSE capacitive buttons. Specifically, the embodiment shown in FIG. 1 imposes a one-to-one relationship between sensor electrode elements of the two MSE capacitive buttons and a plurality of distinct sensor electrodes. This means that the two MSE capacitive buttons 110 and 120 do not have any sensor electrode elements associated with the same sensor electrode. (e.g. sensor electrode elements 117A-117C and 127A-127C all form portions of different sensor electrodes, and capacitive button 110 and 120 have no sensor electrodes in common.)

**[0049]** Although not shown in FIG. 1, one or more sensor electrodes in the capacitive sensing device 100 may be shared. The sharing may occur between any combination of MSE capacitive buttons, non-MSE capacitive buttons, other input devices, and the like. In the case where a sensor electrode is shared between MSE capacitive buttons, a many-to-one relationship exists between sensor electrode elements associated with that shared sensor electrode itself. In such a configuration, multiple sensor electrode elements, each forming a part of a different MSE capacitive button, would belong to the same sensor electrode. This many-to-one relationship allows a set of sensor channels to support more capacitive buttons than possible if a one-to-one relationship is imposed. This is discussed further below.

**[0050]** Regardless of whether or not the sensor electrodes are shared, each MSE capacitive button has at least three sensor electrode elements that are associated with different sensor electrodes. Thus, interaction with a capacitive button would cause changes in at least three sensor electrodes.

**[0051]** In some embodiment, some or all of the sensor electrode elements of an MSE capacitive button have a symmetric layout, and are thus disposed symmetrically. The symmetry may include rotational symmetry, mirror symmetry along one or more axes, or any other applicable form of symmetry. In some other embodiments, some or all of the sensor electrode elements of an MSE capacitive button have

substantially equal areas. In some further embodiments, the sensor electrode elements of an MSE capacitive buttons all meet at a central area of their respective MSE capacitive buttons.

**[0052]** In yet other embodiments of the present technology, the sensor electrode elements of a capacitive button are disposed in such a way that the centers of different sensor electrode elements are substantially the same distance from a center of the capacitive button. Thus, at least two sensor electrode elements of the MSE capacitive button have centers that are substantially equidistant from a center of the MSE capacitive button. One way to gauge distances from the center is to examine estimated centroid locations of the sensor electrode elements and their capacitive button. The estimated centroid locations can be based on the area of each sensor electrode element. For example, in many embodiments where the capacitive button has approximately the shape traced out by its sensor electrode elements, and where the sensor electrode elements of the capacitive button are disposed about the center of the capacitive button symmetrically, a centroid of a first sensor electrode element of the capacitive button and a centroid of a second sensor electrode element of the capacitive button is substantially the same distance from the centroid of the capacitive button. The estimated centroid location can also be based on a weighted area of each sensor electrode element. For example, the areas of sensor electrode elements of an MSE capacitive button may be weighted by the amount of capacitive coupling that the sensor electrode elements are anticipated to have with input objects on a surface above the MSE capacitive button. In some embodiments, the centroid calculation ignores areas of the sensor electrode elements that are expected to experience little or no capacitive coupling changes from users during operation (e.g. areas having far away locations where significant capacitive coupling changes due to user input are expected to occur, areas shielded from effects of user input, and areas having dimensions or shapes that are expected to experience little or no capacitive coupling changes—such as narrow lines).

**[0053]** In further other embodiments, a combination of the above is implemented. For example, the sensor electrode elements of an MSE capacitive button may have both substantially equal areas and a symmetric layout. Examples of this are shown in FIG. 1, where all of the sensor electrode elements of capacitive button 110 (sensor electrode elements 117A-117C) are substantially equal in area and symmetrically disposed about a center of capacitive button 110. Similarly, sensor electrode elements 127A-127C of capacitive button 120 are also substantially equal in area and symmetrically disposed about a center of capacitive button 120.

**[0054]** Referring still to FIG. 1, sensor electrode elements 117A-117C and 127A-127C are ohmically coupled to controller 105 via routing traces 130. Furthermore, as noted in FIG. 1, first capacitive button 110 is noncontiguous with second capacitive button 120. This noncontiguity may be achieved by spacing the sets of sensor electrode elements apart. In some embodiments, first capacitive button 110 and second capacitive button 120 are disposed noncontiguously with respect to each other by spacing the first set of sensor electrode elements from the second set of sensor electrode elements (e.g. 117A-117C from the set of sensor electrode elements 127A-127C) by no less than one-half a finger width. In other embodiments, sensor electrode elements of noncontiguous capacitive buttons may be disposed closer to each other than one-half a finger width. The exact measure of

one-half finger width would depend largely on the size of expected users. For many adult humans, one-half a finger width is about 3-8 (or even up to 10) mm for the pointer, middle, ring, or little fingers, while one-half a finger width would be about 6-12 (or even up to 15) mm for thumbs. The applicable finger width may vary depending on the orientation of the finger relative to the capacitive buttons (e.g. a 2-D projection of the input object presented to the capacitive button may be oval). The button spacing may vary as well with these considerations.

**[0055]** Thus, although FIG. 1 shows first capacitive button 110 in relatively close proximity to second capacitive button 120, FIG. 1 is meant to be a block diagram that is not strictly drawn to scale. Thus, first capacitive button 110 may not be in relatively close proximity to second capacitive button 120 in various physical implementations. For example, capacitive buttons 110 and 120 may be physically far apart, such as on different sides of an electronic display. As other examples, capacitive buttons 110 and 120 may also be spaced to make room for other user input devices such as mechanical switches or pointing sticks, to improve usability, to accommodate industrial design preferences, and the like.

**[0056]** Embodiments in accordance with the present technology are well suited to capacitive buttons having three or more sensor electrode elements each. In many embodiments, the capacitive buttons will have no more than four sensor electrode elements. Where a capacitive button has more than three sensor electrode elements, and especially if the capacitive button has more than four sensor electrode elements, it may be advantageous to ohmically couple some of the sensor electrode elements within the same capacitive button together. For example, for a capacitive button having six sensor electrode elements, it may be advantageous to short every three sensor electrode elements together and use them to form portions of the same sensor electrode. Other embodiments may prefer associating the six sensor electrode elements with 3, 4, 5, or 6 sensor electrodes.

**[0057]** Similarly, embodiments in accordance with the present technology are well suited to use with sensor electrodes that are shared or not shared between capacitive buttons. It should further be noted that embodiments in accordance with the present technology are well suited to any of various sizes, shapes, layouts, configurations, or orientations of sensor electrodes, sensor electrode elements, routing traces, and the like. In many embodiments, the sensor electrode elements of the capacitive button are configured such that the capacitive button has a size that enables actuation by a human digit, such as a finger or a toe.

**[0058]** Referring to FIG. 2A, first capacitive button 110 includes sensor electrode elements  $A_1$ ,  $B_1$  and  $C_1$  and second capacitive button 120 includes sensor electrode elements  $A_2$ ,  $B_2$  and  $D_2$ . Sensor electrode A comprises electrode elements  $A_1$  and  $A_2$ , which are electrically coupled with each other. Sensor electrode B comprises sensor electrode elements  $B_1$  and  $B_2$ , which are electrically coupled with each other. Sensor electrode C comprises electrode element  $C_1$ , and sensor electrode D comprises electrode element  $D_2$ . Thus, these six sensor electrode elements are associated with the four sensor electrodes A, B, C, and D, all of which are electrically coupled to controller 105.

**[0059]** As is discussed, the present technology is well suited to MSE capacitive buttons having sensor electrode elements of varying arrangements, shapes, and sizes. For example, FIG. 4A shows a circular MSE capacitive button

comprising three sensor electrode elements in accordance with embodiments of the present technology. Each of the sensor electrode elements occupies a substantially equal sector of the circular capacitive button shape. This set of sensor electrode elements also has both rotational and mirror symmetries. Further, the sensor electrode elements meet at a center of the capacitive button.

[0060] FIG. 4B shows a MSE capacitive button having an “aperture” 400 in the pattern of sensor electrode elements, in accordance with embodiments of the present technology. Although a circular capacitive button having three sensor electrode elements is shown in FIG. 4B, it is understood that apertures can be introduced in sensor patterns of a variety of different MSE capacitive button designs. The aperture 400 may be a true hole that extends through the sensor electrode pattern and any substrates. Or, the aperture 400 may be simply an area where no sensor electrode element material is placed—the substrate may be solid or something else may be placed in aperture 400.

[0061] In FIG. 4B, a single aperture 400 is shown, positioned in a central region of the capacitive button, and the sensor electrode elements are placed outside and about the aperture. However, other numbers of apertures may be included in a capacitive button, and they may be located in other places other than a central region of the capacitive button. Similar to the example of FIG. 4A, the sensor electrode elements shown in FIG. 4B are about equal in area. The set of sensor electrode elements has both rotational and mirror symmetries, and the sensor electrode elements meet at a center of the capacitive button.

[0062] FIG. 4C shows a square-shaped MSE capacitive button comprising four square-shaped sensor electrode elements in accordance with embodiments of the present technology. Similar to the example of FIG. 4A, each of the sensor electrode elements are about equal in area, the set of sensor electrode elements has both rotational and mirror symmetries, and the sensor electrode elements meet at a center of the capacitive button. While square-shaped sensor electrode elements are shown in FIG. 4C, rectangles of other aspect ratios are possible. For example, other aspect ratios may be more useful depending on the input object size and orientation, on spacing between any capacitive buttons, and the like.

[0063] FIG. 4D shows another rectangular MSE capacitive button. However, this one has three sensor electrode elements in accordance with embodiments of the present technology. These three sensor electrode elements are of unequal shapes, but still have substantially equal areas. The set of sensor electrode elements also has mirror symmetry, and the sensor electrode elements meet at a center of the capacitive button.

[0064] The embodiments shown in FIGS. 4C and 4D are examples of capacitive buttons with rectilinear portions, where each button has sensor electrode elements with angular sections. In addition to rectangles, other such capacitive buttons with rectilinear portions and angular sensor electrode elements are possible. For example, the capacitive button may have a “T” or “+” shape.

[0065] FIG. 4E shows a circular MSE capacitive button comprising four sensor electrode elements in accordance with embodiments of the present technology. Like the example shown in FIG. 4A, each of the sensor electrode elements occupies an approximately equally-sized sector of a circle. The set of sensor electrode elements also has both rotational and mirror symmetries, and the sensor electrode elements meet at a center of the capacitive button.

[0066] FIG. 4A-4E all show sets of sensor electrode elements where all sensor electrode elements in a set have substantially equal areas. However, some embodiments may have sets where only some or none of the sensor electrode elements are similar in area. Similarly, FIG. 4A-4E all show sets of sensor electrode elements that have some type of symmetry and all meet at a center of the capacitive button and other common characteristics. However, other embodiments may not have such characteristics.

[0067] Continuing with FIG. 2A, a block diagram is shown of an example capacitive sensing device 100 with a controller coupled with noncontiguous capacitive buttons in accordance with embodiments of the present technology. The first capacitive button, typically shown as 205, is disposed on substrate 107. First capacitive button 205 is coupled with controller 105 via routing traces typically shown as 130. First capacitive button 205 is comprised of three sensor electrode elements  $A_1$ ,  $B_1$ , and  $C_1$ . Dielectric material such as plastic (not shown) usually covers any conductive material (e.g. material comprising the sensor electrode elements and routing traces) that would otherwise be exposed to an assembler or user. In various embodiments, this protects the sensor electrode elements from the environment, prevents electrical shorts between an input object and the conductive material, and/or controls the capacitive coupling experienced by the sensor electrodes.

[0068] Similarly, a second capacitive button, typically shown as 210, is also disposed on substrate 107 and coupled with controller 105 via routing traces typically shown as 130. Second capacitive button 210 is comprised of three sensor electrode elements  $A_2$ ,  $B_2$ , and  $D_2$ . Of note and as described herein, sensor electrode elements  $A_1$  and  $A_2$  are ohmically coupled with each other by both being routed to one sensing channel of controller 105 (a first sensing channel). Thus, sensor electrode elements  $A_1$  and  $A_2$  are sensor electrode elements of the first and second capacitive buttons 205 and 210, respectively, and are associated with a same sensor electrode A. Specifically, each of the sensor electrode elements  $A_1$  and  $A_2$  forms a portion of sensor electrode A, and sensor electrode A is shared by the first and second capacitive buttons 205 and 210. Similarly, sensor electrode elements  $B_1$  and  $B_2$  form one sensor electrode B and are routed to one sensing channel of controller 105 (a second sensing channel). Thus, electrode elements  $B_1$  and  $B_2$  are sensor electrode elements of the first and second capacitive buttons, 205 and 210, respectively, and are associated with the same sensor electrode B, and sensor electrode B is shared by the first and second capacitive buttons 205 and 210. Also of note is that sensor electrode elements  $C_1$  and  $D_2$  are not routed to any other sensor electrode elements. Thus, sensor electrode C is part of the first capacitive button 205 only, and sensor electrode D is part of the second capacitive button 210 only. Embodiments in accordance with the present technology are well suited to use with various numbers of shared sensor electrodes. In those embodiments where capacitive buttons have shared electrodes, the capacitive buttons are constructed to have at least one sensor electrode not in common (i.e. the combinations of sensor electrodes associated with the capacitive buttons differ).

[0069] In the upper portion of FIG. 2A, first capacitive button 205, second capacitive button 210, and portions of routing traces 130 are shown disposed within an upper dotted box T. As discussed below in detail, for purposes of clarity, FIG. 2A also includes an enlarged view of the features disposed within a lower dotted box T.

[0070] Controller 105 includes or is coupled with activation identification mechanism 220. Controller 105 may also include or be coupled with positional characteristics analyzing unit 218, if positional characteristics are determined as part of the button actuation analysis process. The functional operation of positional characteristics analyzing unit 218 and activation identification mechanism 220 are discussed below in detail.

[0071] FIG. 2A also shows a disambiguating electrode 215 as a dotted box. Disambiguating electrode 215 is disposed proximate to the set of sensor electrode elements of the first capacitive button 205. Disambiguating electrode 215 is configured to help distinguish user input intended to actuate the first capacitive button 205 from user input not intended to actuate the first capacitive button 205.

[0072] In many embodiments, disambiguating electrode 215 generates indicia reflecting changes in capacitive coupling experienced by the disambiguating electrode 215. Controller 105 processes the indicia from disambiguating electrode 215 to produce electrode values correlated to the disambiguating electrode 215. Controller 105 examines these disambiguating electrode values to better distinguish between input intended to cause button actuation and input not intended to cause button actuation.

[0073] For example, the disambiguating electrode values may help controller 105 differentiate between input provided by multiple smaller objects in the sensing region and input provided by a single, larger object in the sensing region. In many embodiments, input provided by multiple, smaller objects may be more likely to provide valid button input (e.g. it may be caused by finger presses), and input provided by a single, large object may be less likely to provide valid button input (e.g. it may be caused by palms of hands or cheeks of faces). Thus, in some embodiments, controller 105 is configured to suppress button actuations when a large object is determined to be interacting with the capacitive button arrangement. In some other embodiments, controller 105 is configured to inhibit (e.g. reject, suppress, or ignore) user inputs or indicia that would otherwise cause button actuations in response to disambiguating electrode values that indicate high enough probabilities that the user inputs are not meant to result in button actuations.

[0074] Although FIG. 2A shows disambiguating electrode 215 as a single, large electrode surrounding both first and second capacitive buttons 205 and 210, it is understood that other embodiments may not implement any disambiguating electrodes. In addition, other embodiments may implement any number of disambiguating electrodes with any shape, size, and configuration applicable to the capacitive sensing device design. For example, a disambiguating electrode may be implemented as a conductive trace or pattern located between sets of sensor electrode elements of two different capacitive buttons.

[0075] Referring now to FIG. 2B, a block diagram of example noncontiguous first and second capacitive buttons with interdigitated sensor electrode elements, in accordance with embodiments of the present technology is shown. In various embodiments, the first capacitive button 205 has a first set of sensor electrode elements. The first set of sensor electrode elements includes at least three sensor electrode elements associated with distinct sensor electrodes, and at least two sensor electrode elements of that first set are physically interdigitated with each other. That is, portions of at least two sensor electrode elements “poke into” each other. In

the case shown in FIG. 2B, first capacitive button 205 comprises a set of three sensor electrode elements,  $A_1$ ,  $B_1$ , and  $C_1$ , all of which are interdigitated with each other, Thorn-shaped features (feature 230 is labeled for sensor electrode element  $A_1$ ) of each sensor electrode element,  $A_1$ ,  $B_1$ , and  $C_1$ , extend into a thorn-shaped space in an adjacent electrode element,  $B_1$ ,  $C_1$ , and  $A_1$ . Of note, embodiments of the present technology are well suited for interdigitation in any number of shapes and forms, and numbers and shapes other than single thorns are contemplated.

[0076] FIGS. 5A, 5B, and 5C show arrangements useful in some embodiments using “transcapacitive” sensing schemes. “Absolute” capacitive sensing schemes focus on changes in the amount of capacitive coupling between objects external to the sensing devices and sensor electrodes of the sensing device. In contrast, “transcapacitive” sensing schemes focus on changes in the amount of capacitive coupling between electrodes of the sensing device. Some transcapacitive embodiments of capacitive buttons, each having at least three sensor electrode elements, utilize separate emitter and receiver sensor electrode elements. The emitter sensor electrode elements are parts of emitter sensor electrodes, which are sensor electrodes capable of emitting electrical signals. The receiver sensor electrode elements are part of receiver sensor electrodes, which are sensor electrodes capable of receiving electrical signals from emitter sensor electrodes. Some transcapacitive embodiments of capacitive buttons, each having at least three sensor electrode elements, utilize sensor electrode elements of sensor electrodes capable of both emitting and receiving electrical signals. In many embodiments using either absolute or transcapacitive sensing, the objects external to the sensing devices are coupled to the chassis grounds of the sensing devices.

[0077] Referring now to FIG. 5A, a diagram of a capacitive button with a separate emitter sensor electrode element 500 surrounding receiver sensor electrode elements 505, 510, and 515 is shown in accordance with embodiments of the present technology. The emitter sensor electrode element 500 is associated with an emitter sensor electrode. In the embodiment shown in FIG. 5A, there is one emitter sensor electrode element 500 per capacitive button, although multiple emitter sensor electrode elements may be included per capacitive button. Thus, in transcapacitive sensing schemes such as those described in conjunction with FIG. 5A, the capacitive button arrangement includes at least one emitter sensor electrode element that is capacitively coupled with the set of receiver sensor electrode elements of the capacitive button. The emitter sensor electrode element is configured to emit electrical signals to be received by the set of receiver sensor electrode elements.

[0078] Emitter sensor electrode element 500 may surround the receiver sensor electrode elements 505, 510, and 515 that receive signals emitted by the emitter sensor electrode element 500, as shown in FIG. 5A. However, in other embodiments and as shown in FIG. 5B, the emitter sensor electrode element may be in an internal portion, such as a central portion, of the capacitive button. The internally located emitter sensor electrode element is surrounded by the receiver sensor electrode elements configured to receive signals emitted by the emitter sensor electrode.

[0079] It is understood that if additional MSE capacitive buttons are introduced to the arrangement shown in FIG. 5A, the emitter sensor electrode including emitter sensor electrode element 500 may or may not be shared between the

capacitive buttons. That is, each capacitive button may have its own emitter sensor electrode element, or multiple capacitive buttons may share the same emitter sensor electrode (or even the same emitter sensor electrode element, if the element is properly shaped and placed). Similarly, receiver sensor electrodes may be shared or not shared between any MSE capacitive buttons added to the configuration shown in FIG. 5A.

[0080] It is also understood that the configuration shown in FIG. 5A can be driven in other ways. For example, in some embodiments, the element 500 is a receiver sensor electrode element, while the elements 505, 510, and 515 are independent emitter sensor electrode elements.

[0081] Referring now to FIG. 5B, a diagram of a capacitive button with a separate emitter sensor electrode element 520 surrounded by receiver sensor electrode elements 525, 530, and 535 in accordance with embodiments of the present technology is shown. In the embodiment shown in FIG. 5B, emitter sensor electrode element 520 may be in a central portion of the capacitive button, surrounded by the receiver sensor electrode elements 525, 530, and 535, and configured to receive signals emitted by emitter sensor electrode element 520.

[0082] Referring now to FIG. 5C, a diagram of a capacitive button with three sensor electrode elements 540, 545, and 550, at least one of which is capable of emitting as well as sensing signals in accordance with embodiments of the present technology, is shown. The sensor electrode elements 540, 545, and 550 are associated with distinct sensor electrodes A, B, and C, respectively. At least one of the distinct sensor electrodes (e.g. A, B, and/or C) associated with the sensor electrode elements 540, 545, and 550 of the capacitive button is capable of both emitting and receiving electrical signals. In such a case, the sensor electrode elements 540, 545, and 550, may be interdigitated with each other as shown in FIG. 5C, interdigitated in some other manner (e.g. 2B), or not be interleaved at all (e.g. have shapes similar to what are shown in the other figures).

[0083] In one embodiment of the example shown in FIG. 5C, the following process occurs during operation. At a first time, sensor electrode A emits signals while sensor electrodes B C receive. Then, at a second time, sensor electrode B emits signals while at least sensor electrode C receives. This approach provides interaction information between sensor electrodes A-B, A-C, and B-C, which provides three independent capacitive measurements based on the three sensor electrodes A-C having sensor electrode elements in the capacitive button.

[0084] It can be seen that multiple other ways of implementing transcapacitive sensing using the configuration shown in FIG. 5C are possible. For example, adding to the process described above, sensor electrode A can also receive during the second time when sensor electrode B emits. Alternatively, also adding to the process described above, there can be a third time during which sensor electrode C emits while sensor electrodes A and B receive. As a separate example, sensor electrodes A and B can emit different signals while sensor electrode C receives during a first time, then sensor electrode A can emit while at least sensor electrode B receives.

[0085] It is understood that if additional MSE capacitive buttons are introduced to the arrangement shown in FIG. 5C, the sensor electrodes may or may not be shared or not shared between capacitive buttons. Emitter sensor electrodes are

also termed “drivers,” “driver electrodes,” “driver sensor electrodes,” “emitters,” “emitter electrodes,” and the like. Receiver electrodes are also termed “detectors,” “detector electrodes,” “detector sensor electrodes,” “receivers,” “receiver electrodes,” and the like.

[0086] Accidental button actuation is often a bigger issue in embodiments sharing sensor electrodes between capacitive buttons than in embodiments not sharing sensor electrodes between capacitive buttons. This is because, when sensor electrodes are shared between capacitive buttons, inputs that interact with different sensor electrode elements of different capacitive buttons may produce results that mimic inputs that properly actuate another capacitive button. As a more specific example, a capacitive button arrangement with shared sensor electrodes may include a first capacitive button having three sensor electrode elements belonging to of sensor electrodes A-B-C, a second capacitive button having three sensor electrode elements belonging to sensor electrodes B-C-D, and a third capacitive button having three sensor electrode elements belonging to sensor electrodes A-C-D. An input that interacts with sensor electrode elements B and C of the second capacitive button and sensor electrode element A of the third capacitive button may mimic an input that properly interacts with sensor electrode elements A, B, and C of the first capacitive button. This may result in an unintended actuation of the first capacitive button.

[0087] Referring to FIG. 6A, a diagram of four capacitive buttons, 600, 605, 610, and 615 sharing four sensor electrodes in accordance with embodiments of the present technology is shown. The capacitive button arrangement shown in FIG. 6A disposes buttons 600, 605, 610, and 615 in a straight line. Other embodiments may involve layouts with more or fewer capacitive buttons in linear or nonlinear arrangements. For example, various embodiments may include radically different numbers of capacitive buttons laid out in substantially different patterns.

[0088] In the embodiment shown in FIG. 6A, each of the capacitive buttons comprises a set of at least three sensor electrode elements. The orientation of the different capacitive buttons and the layout of the different sensor electrode elements associated with the same sensor electrodes in those capacitive buttons are selected such that the sensor electrode elements are positioned to correspond with each other in a way that places them closer together. This design can help reduce accidental button actuation, especially when sensor electrodes are shared between capacitive buttons. For example, an input that interacts with all of one capacitive button and accidentally interacts with a small part of an adjacent capacitive button may trigger fewer accidental actuations. This may be especially helpful in cases where capacitive buttons are placed less than half an input object width apart (e.g. less than half a finger width apart).

[0089] In some embodiments, a first capacitive button has a first set of sensor electrode elements and a second capacitive button has a second set of sensor electrode elements. A sensor electrode element of the first set is associated with the same sensor electrode as a sensor electrode element of the second set. The sensor electrode element of the first set is disposed to be physically closer to the sensor electrode element of the second set than any other sensor electrode element of the second set. Depending on the embodiment, the distance used to compare closeness can be the shortest distance from closest parts of sensor electrode elements, from centers of the sensor electrode elements, or the like. For some capacitive button

designs, the resulting arrangement can be termed to have sensor electrode elements of shared sensor electrodes “face” each other in adjacent capacitive buttons.

[0090] In the embodiment shown in FIG. 6A, first capacitive button 600 and second capacitive button 605 each has three sensor electrode elements, and first capacitive button 600 and second capacitive button 605 have at least one shared sensor electrode in common. Specifically, sensor electrode A has sensor electrode elements in the first and second capacitive buttons 600 and 605 (sensor electrode elements  $A_1$  in the first capacitive button 600 and sensor electrode elements  $A_2$  in the second capacitive button 605). The  $A_1$  sensor electrode element is arranged to be physically closer to the  $A_2$  sensor electrode element than to any of the other sensor electrode elements of the second capacitive button 605. As further examples, similar placements can be seen for the  $D_3$  and  $D_4$  sensor electrode elements of third capacitive button 610 and fourth capacitive button 615. It is understood that sensor electrode elements of shared sensor electrodes need not be arranged in such a way between adjacent capacitive buttons.

[0091] Also shown in FIG. 6A is how sensor electrode elements of a shared sensor electrode may be disposed on a same side of the capacitive button arrangement. In some embodiments, a first capacitive button has a first set of sensor electrode elements and a second capacitive button has a second set of sensor electrode elements. A first sensor electrode element of the first set is associated with the same sensor electrode as a second sensor electrode element of the second set. The first sensor electrode element and the second sensor electrode element are disposed on a same side of the capacitive button arrangement. This design can help reduce accidental button actuations, especially when sensor electrodes are shared between capacitive buttons. For example, if input is presented from that same side where the first and second sensor electrode elements are disposed, and interacts with multiple capacitive buttons, fewer accidental button actuations may result.

[0092] In the embodiment shown in FIG. 6A, first capacitive button 600, second capacitive button 605, and third capacitive button 610 each has three sensor electrode elements, and all three capacitive buttons 600, 605, and 610 share sensor electrode B (sensor electrode element  $B_1$  in the first capacitive button 600, sensor electrode element  $B_2$  in the second capacitive button 605, and sensor electrode element  $B_3$  in the third capacitive button 610). The sensor electrode elements  $B_1$  and  $B_2$  are arranged to both be on the same side of the arrangement (the “top” side of FIG. 6A as shown). Similarly, sensor electrode elements  $B_2$  and  $B_3$  are arranged to both be on the same side of the arrangement, as are sensor electrode elements  $B_1$  and  $B_3$ . In fact, all three sensor electrode elements  $B_1$ ,  $B_2$ , and  $B_3$  are arranged to be on the same side. As a further example, similar placements can be seen for the  $C_2$ ,  $C_3$  and  $C_4$  sensor electrode elements of second capacitive button 605, third capacitive button 610, and fourth capacitive button 615 (on a “bottom” side of FIG. 6A as shown). It is understood that sensor electrode elements of shared sensor electrodes need not be arranged in such a way.

[0093] Referring to FIG. 6B, a diagram of four other capacitive buttons 650, 655, 660, and 665 sharing four sensor electrodes in accordance with embodiments of the present technology is shown. Each of the capacitive buttons 650, 655, 660, and 665 comprises a set of at least three sensor electrode elements. Sensor electrode elements associated with the same sensor electrode are positioned to correspond with each other

in a way that places them farther apart. This design can help reduce accidental button actuation, especially when sensor electrodes are shared between capacitive buttons. For example, an input that simultaneously interacts with large parts of multiple capacitive buttons may trigger fewer accidental actuations. This may be especially helpful in cases where capacitive buttons are placed more than half an input object width apart (e.g. more than half a finger width apart).

[0094] In many such embodiments where multiple capacitive buttons share multiple sensor electrodes, the minimum separation distance between sensor electrode elements of shared sensor electrodes are substantially maximized.

[0095] In some embodiments, a first capacitive button has a first set of sensor electrode elements and a second capacitive button has a second set of sensor electrode elements. A first sensor electrode element of the first set is associated with the same sensor electrode as a second sensor electrode element of the second set. The first sensor electrode element is disposed to be physically farther away from the second sensor electrode element than any other sensor electrode element of the second set of sensor electrode elements.

[0096] In the embodiment shown in FIG. 6B, the capacitive buttons 650, 655, 660, 665 each has three sensor electrode elements associated with sensor electrodes chosen from a plurality of four sensor electrodes A-D. As can be seen in FIG. 6B, the sensor electrode elements of the same sensor electrode are placed as far apart from each other as reasonable. For example, sensor electrode element  $C_1$  of first capacitive button 650 is farther apart from sensor electrode element  $C_2$  of second capacitive button 655 than the other sensor electrode elements  $A_2$  and  $B_2$  of second capacitive button 655.

[0097] FIG. 7 is a block diagram of an example arrangement of capacitive buttons in accordance with embodiments of the present technology. FIG. 7 illustrates embodiments where neighboring capacitive buttons are designed not to share any sensor electrodes (have no sensor electrodes in common). This is accomplished by arranging the capacitive buttons and their associated sets of sensor electrode elements such that a first and second capacitive button having shared sensor electrodes are separated by a third capacitive button having no sensor electrodes in common with the first and second capacitive buttons.

[0098] Said in another way, FIG. 7 illustrates embodiments where a capacitive sensing device has a first capacitive button having a first set of sensor electrode elements and a second capacitive button having a second set of sensor electrode elements. The first and second capacitive buttons share at least one sensor electrode, such that a first sensor electrode element of the first set and a second sensor element of the second set are associated with a same sensor electrode. The capacitive sensing device further includes a third capacitive button with a third set of sensor electrode elements disposed between the first set of sensor electrode elements and the second set of sensor electrode elements. The third set of sensor electrode elements has at least three sensor electrode elements associated with distinct sensor electrodes, where no sensor electrode element of the third set of sensor electrode elements belongs to the same sensor electrode as any sensor electrode element of the first or second sets of sensor electrode elements.

[0099] Rectangular capacitive buttons are shown in FIG. 7, with each capacitive button having a set of sensor electrode elements. Two groups of capacitive buttons (group m and group n) are shown in FIG. 7, and include non-overlapping

pluralities of sensor electrodes (sensor electrodes A-D and sensor electrodes E-H). As shown in FIG. 7, capacitive buttons in group m (capacitive buttons 700, 710, 725, and 735) share sensor electrodes A-D, and capacitive buttons in group n (capacitive buttons 705, 715, 720, and 730) share sensor electrodes E-H.

[0100] As shown in FIG. 7, the capacitive buttons are arranged such that capacitive buttons in group m (capacitive buttons 700, 710, 725, and 735) are separated by capacitive buttons outside of group m. Specifically, they are interspersed with capacitive buttons in group n (capacitive buttons 705, 715, 720, and 730). Thus, in this arrangement, neighboring capacitive buttons do not share any sensor electrodes. This approach may be helpful in avoiding unintentional button actuations. For example, a particular large input object that simultaneously interacts with multiple neighboring capacitive buttons would be less likely to trigger a valid combination of sensor electrode responses. As a specific example, no capacitive button shown in FIG. 7 uses the sensor electrode combination of B-A-H. An input object located between capacitive buttons 700 and 705 may trigger such a response, but would not accidentally actuate another button.

[0101] In many embodiments with where multiple capacitive buttons share multiple sensor electrodes, some capacitive buttons are placed close to each other while other capacitive buttons are placed far apart. In such cases, the approaches illustrated in FIGS. 6A, 6B, and 7 can be combined as appropriate. For example, the orientation and/or positioning of the sensor electrode elements of some capacitive button combinations (e.g. those close to each other) can be selected to optimize for the approach shown in FIG. 6A, while the orientation and/or positioning of sensor electrode elements of other capacitive button combinations (e.g. those far apart from each other) can be selected to optimize the approach shown in FIG. 6B. As another example, different groups of capacitive buttons (the groups sharing non-overlapping pluralities of sensor electrodes) can be placed to increase or decrease the distance between sensor electrode elements of the same sensor electrode, as appropriate. For example, the orientation and positioning of the sensor electrode elements shown in FIG. 7 are selected for a separation distance between the upper and lower rows of capacitive buttons that is large compared to the typical width of expected input objects, and for a separation distance between same-group-buttons in the same row is greater than the typical width of expected input objects.

[0102] FIG. 8 is a cross-sectional view of a tactile feature configured to provide tactile feedback for a capacitive button in accordance with embodiments of the present technology. Specifically, FIG. 8 shows tactile feature 805 disposed proximate to a capacitive button (not shown) located in structure 810. Tactile feature 805 can be used to provide tactile feedback to input object 800 (a finger is shown) to help a user in locating the capacitive button in structure 810, or to help inform a user of button actuation as the input object 800 interacts with the capacitive button located in structure 810. In particular, the tactile feedback may be used to help the user locate the input object 800 laterally.

[0103] Although a single protrusion is shown in FIG. 8, it is understood that any combination of protrusions, ridges, depressions, textures, other elements, and the like can be used to provide tactile feedback feature 805. Further, embodiments

may position tactile features around or about central regions of capacitive buttons, or elsewhere in relation to the capacitive buttons.

#### Operation

[0104] As discussed above, in embodiments in accordance with the present technology, a capacitive button comprising a set of at least three sensor electrode elements associated with distinct sensor electrodes, offer improved button performance. Indicia received from sensor electrodes associated with a capacitive button are used to determine electrode values. These electrode values are utilized to determine the actuation status of the capacitive button. Positional characteristics about one or more input objects may be determined while gauging the actuation status of a capacitive button. Thus, determining the actuation status of the capacitive button may involve determining one or more positional characteristics of one or more input objects, and distinguishing between input intended for button actuation from other input not intended for button actuation (e.g. swiping gestures, input that interacts with multiple capacitive buttons simultaneous, and the like).

[0105] In some embodiments, a capacitive button may be tuned to actuate if an input object makes physical contact with a surface correlated with the capacitance button, and not if the input object is not in contact with the surface. However, physical contact is not inherently required for interaction with a capacitive button. An input object in a sensing region of the capacitive button, and hovering over a surface correlated to the capacitive button, may interact with it. Enough changes in capacitive coupling may result from such hovering input object for button actuation to occur. Thus, in other embodiments of the present technology, a capacitive button may be tuned to actuate in some cases when the input object is not in contact with any surfaces correlated with the capacitive button.

[0106] As will be described in detail below, FIGS. 3A-3E show representations of an input object interacting with capacitive buttons. Specifically, FIGS. 3A-3E show input object 300 (shown as a finger) located in various locations in the capacitive sensing region of first and second capacitive buttons 205 and 210, respectively. The specific discussions regarding FIGS. 3A-3E refers to using an absolute capacitance sensing scheme. However, it is understood that similar results can be achieved using other sensing schemes, including transcapacitive sensing schemes.

[0107] Although not shown in FIG. 3A, coupled with the first and second capacitive buttons 205 and 210 is a controller, such as the controller 105 of FIG. 2A. As previously noted, controller 105 can be couple with or include activation identification mechanism 220 of FIG. 2A for interpreting electrode values to determine button actuation.

[0108] Activation identification mechanism 220 is used to determine activation status of sensor electrodes, and may be implemented as circuitry, as software, or a combination thereof. In some embodiments, a sensor electrode is considered to be active if its associated electrode value is greater than or equal to an activation threshold value, and inactive if its associated electrode value is less than the activation threshold value. Different sensor electrodes may have the same or different activation threshold values.

[0109] In some embodiments, activation identification mechanism 220 may impose requirements such as particular trends of sensor electrode values over time to switch the

determined state of a sensor electrode. For example, activation identification mechanism 220 may determine that a previously inactive sensor electrode is active if its associated electrode values crossed its activation threshold value in a particular way over time (e.g. increasing over time from below to above the applicable threshold value, or vice versa).

[0110] Further, some embodiments may impose “deactivation” threshold values that differ from activation threshold values on sensor electrodes considered to be in active states. Using differing activation and deactivation threshold values introduces hysteresis that may help “debounce” activation determinations. In other words, having hysteresis helps prevent “fluttering” of activation status for electrode values that are close to a threshold, such that determinations of status would not quickly swap between activated and inactivated states.

[0111] Similarly to activation threshold values, distinct sensor electrodes may have the same or different deactivation threshold values. The activation identification mechanism 220 may similarly impose requirements for recognizing no activation such as particular trends of sensor electrode values over time. For example, activation identification mechanism 220 may determine that a sensor electrode is inactive if its associated electrode values crossed the applicable activation threshold value in a particular way over time (e.g. decreasing over time from above to below the applicable threshold value, or vice versa). The required activation trends and the required deactivation trends can differ (e.g. differ in direction, magnitude, etc.).

[0112] In some embodiments, activation statuses of sensor electrodes have little or no effect on processing. For example, all of the sensor electrodes may always be producing indicia at a set frequency, processing may always be occurring at a constant rate, or the like. In contrast, in some embodiments, activation status is used to control processing such as sampling rate of indicia from the sensor electrodes, generation of electrode values, calculation of positional characteristics, determination of button actuations, and the like. This approach can be used to save power by reducing the amount of sampling or processing activity when there is no user input to the capacitive buttons.

[0113] In some embodiments, at least some of the sensor electrodes are not used to produce indicia, or at least some of the electrode values that can be calculated are not, until after the activation identification mechanism 220 provides one or more indications that trigger such production. For example, the trigger can include that at least one of the sensor electrodes is activated, that at least some number of sensor electrodes are activated, that a select group of sensor electrodes are activated, that at least some number of a select group of sensor electrodes are activated, and the like.

[0114] Similarly, in some embodiments, the rate at which sensor electrodes are used to produce indicia is slower until the activation identification mechanism 220 provides one or more indications that trigger a higher rate. Some other embodiments may use indications from the activation identification mechanism 220 to affect the rate at which electrode values are generated, which sensor electrodes the electrode values are generated, which buttons actuation status is determined for (if any), and the like.

[0115] In a simple embodiment, a capacitive button is determined to be actuated when all of the sensor electrodes correlated with the capacitive button are active.

[0116] Controller 105 can further couple with or include positional characteristics analyzing unit 218 for determining button actuation. In some embodiments, positional characteristics analyzing unit 218 is configured to determine one or more positional characteristics of one or more input objects with respect to a capacitive button system. These positional characteristics are then evaluated against various criteria for gauging button actuation.

[0117] Some embodiments include disambiguating electrodes such as disambiguating electrode 215 (shown in FIG. 2A). In such embodiments, the controllers (e.g. controller 105 of FIG. 2A) may also process the indicia from disambiguating electrodes to produce disambiguating electrode values. The controllers may then use the disambiguating electrode values in effecting button actuation. For example, the controllers may reject or suppress potential button actuations if the disambiguating electrode values indicate something else aside from what appears to be a valid button press (e.g. the presence of a relatively large object such as a palm of a hand, a face, or other non-button input body part).

[0118] Referring now to FIG. 3A, a block diagram of first and second capacitive buttons 205 and 210, respectively, is shown in accordance with embodiments of the present technology. First capacitive button 205 comprises sensor electrode elements  $A_1$ ,  $B_1$  and  $C_1$  of sensor electrodes A, B, and C. Second capacitive button 210 comprises sensor electrode elements  $A_2$ ,  $B_2$ , and  $D_2$  of sensor electrodes A, B, and D. Input object 300 (a finger is shown), is located at first position 305 over a small portion of the right side of second capacitive button 210.

[0119] In such a case, the sensor electrodes A-D of the first and second capacitive buttons 205 and 210 would provide indicia that are received by a controller such as controller 105 of FIG. 2A. As appropriate, controller 105 utilizes indicia received from sensor electrodes A-D to generate electrode values, where at least three electrode values are associated with each capacitive button (e.g. capacitive buttons 205 and 210). As shown in FIG. 3A, first capacitive button 205 and second capacitive button 210 share sensor electrodes, thus electrode values are generated only for four sensor electrodes A-D even though there are six sensor electrode elements. Some of the same electrode values are correlated with both capacitive buttons 205 and 210. The generated electrode values are then utilized to determine button actuation status. This may involve using the electrode values to determine positional characteristics of the input object 300 in relation to first and second capacitive buttons 205 and 210, respectively.

[0120] Referring again to FIG. 3A, the input object 300 is located at first position 305, above and “vertically” close to and directly above a sliver of sensor electrode element  $A_2$  of second capacitive button 210. In the discussion below, “vertical” is used to describe the dimension into and out of the figure as drawn, while “lateral” is used to describe the two dimensions that define planes parallel to the figure as drawn.

[0121] The indicia provided by sensor electrodes A-D are reflective of the effect of input object 300 on the amount of capacitive coupling sensed by sensor electrodes A-D. Thus, the indicia provided by sensor electrodes A-D would result in electrode values reflective of the input object 300 being close to and directly above a small portion of sensor electrode element  $A_2$  of second capacitive button 210. In most embodiments, the indicia would reflect changes in capacitive coupling with sensor electrode element  $A_2$  due to the overlapping input object 300, and perhaps smaller changes in capacitive



coupling with sensor electrode element  $D_2$  due to fringe capacitance. Controller 105 would process the received indicia and arrive at electrode values that describe no input object overlapping with a small part of sensor electrode A, close to sensor electrode D, and not close to sensor electrodes B and C. In some embodiments, with such a set of electrode values, controller 105 would determine that the input object is somewhere near the right side of the second capacitive button 210, since that is the location where a single input object would be able to trigger such a set of electrode values. In some embodiments, second capacitive button 210 would not be determined to be actuated in such a case.

[0122] As discussed above, in some embodiments, the electrode values generated for what is shown in FIG. 3A would likely indicate that no activation thresholds have been satisfied. This result may affect the sampling or the processing of data by the capacitive sensing device. For example, in some embodiments, this may stop processing of input or sampling at a slower rate. As another example, in other embodiments, the electrode values generated for what is shown in FIG. 3A may indicate interaction sufficient to trigger further processing of input or to begin sampling at a higher rate.

[0123] Referring now to FIG. 3B, a block diagram of capacitive buttons is shown in accordance with embodiments of the present technology. First and second capacitive buttons 205 and 210 are shown with input object 300 at a second position 310 over the entire set of sensor electrode elements  $A_2$ ,  $B_2$ , and  $D_2$  of second capacitive button 210. Sensor electrode elements  $A_2$ ,  $B_2$ , and  $D_2$  are parts of sensor electrodes A, B, and D, respectively. The sensor electrodes A-D provide indicia relating to input object 300 at second position 310, which reflects input object 300 interacting with sensor electrodes A, B, and D. Controller 105 utilizes the indicia from sensor electrodes A-D to generate the electrode values usable for gauging button actuation.

[0124] In many embodiments, activation identification mechanism 220 would indicate that activation threshold values for the sensor electrodes A, B, and D have been exceeded in a case as shown in FIG. 3B. Since A-B-D is a valid capacitive button combination (that of second capacitive button 210), a simple implementation may determine that second capacitive button 210 is actuated based only on these values.

[0125] More complex implementations may examine one or more positional characteristics determined by a positional characteristics analyzing unit 218 to determine button actuation. These more complex implementations would determine and evaluate if select positional characteristics meet particular criteria required for actuating second capacitive button 210. For example, some embodiments may pose requirements on the prior location(s) of the input object 300. In some embodiments, if input object 300 moved in toward the button laterally (e.g. from position 305) before reaching second position 310, then controller 105 may not recognize a button actuation. However, if input object 300 arrived in vertically to position 310 without much lateral movement, the controller 105 may recognize a button actuation.

[0126] Continuing now with FIG. 3C, a block diagram of capacitive buttons is shown in accordance with embodiments of the present technology. First and second capacitive buttons 205 and 210, respectively, are shown with input object 300 at a third position 315 over a left portion of sensor electrode elements  $A_2$ ,  $B_2$ , and  $D_2$  of second capacitive button 210. Specifically, input object 300 of FIG. 3C is disposed close to and covers portions of sensor electrode elements  $B_2$ , and  $D_2$

of sensor electrodes B and D. The indicia provided by sensor electrodes A-D provide reflect input object 300 at third position 315, which reflects input object 300 interacting mostly with sensor electrodes B and D.

[0127] Third position 315 places the input object 300 a bit off-center over sensor electrode element  $B_2$  of second capacitive button 210. This means that the resulting indicia and electrode values would reflect a relatively larger amount of user interaction with sensor electrode B and a relatively lesser amount of user interaction with sensor electrode D. In some embodiments, sensor electrode A results may also be slightly affected due to fringing effects (although such effects are likely to be minimal) and sensor electrode C results are not significantly affected.

[0128] In many embodiments, actuation identification mechanism 220 would indicate that sensor electrodes B and perhaps D are activated, and second capacitive button 210 would not be determined to be actuated. Controller 105 may determine no button actuation independent of prior interaction by input object 300 with first and second capacitive buttons 205 and 210 (e.g. independent of how input object 300 reached third position 315).

[0129] Continuing now with FIG. 3D, a block diagram of capacitive buttons is shown in accordance with embodiments of the present technology. First and second capacitive buttons 205 and 210, respectively, are shown with input object 300 at a fourth position 320 between first and second capacitive buttons 205 and 210. Input object 300 of FIG. 3D is not near any portions of first and second capacitive buttons 205 and 210. Hence, indicia from sensor electrodes A-D would reflect such, and no button actuation results.

[0130] It is worth noting that input object 300 in fourth position 320 overlaps with the routing traces of all four sensor electrodes A-D. Thus, it may be possible for input object 300 to interact capacitively with the routing traces, affect the indicia generated by sensor electrodes A-D, and cause incorrect button actuations. In most embodiments, this potential problem can be addressed by positioning the routing traces farther away from the input object 300 in the third dimension (into and out of the page in FIG. 3D), by proper shielding of the routing traces, by disposing the routing traces elsewhere (e.g. in areas that input objects are unlikely to be near), minimizing the area available for capacitive coupling, a combination thereof, or the like.

[0131] Referring now with FIG. 3E, a block diagram of capacitive buttons is shown in accordance with embodiments of the present technology. First and second capacitive buttons 205 and 210, respectively, are shown, with input object 300 at a fifth position 325 over first capacitive button 205.

[0132] Input object 300 of FIG. 3E is positioned over a right portion of the sensor electrode elements  $A_1$ ,  $B_1$  and  $C_1$  of first capacitive button 205, and covers portions of sensor electrode elements  $B_1$  and  $C_1$  of sensor electrodes B and C. The sensor electrodes A-D provide indicia relating to input object 300 at fifth position 325, which reflects input object 300 interacting mostly with sensor electrodes B and C. In many embodiments, the change in capacitive coupling is sufficient to cause sensor electrode B, and perhaps sensor electrode C, to be activated. In some embodiments, sensor electrode A results may also be slightly affected due to fringing effects (although such effects are likely to be minimal) and sensor electrode D results are not significantly affected. In many embodiments, with such a set of indicia and resulting sensor electrode values, no button actuation is recognized.

[0133] Referring now to FIG. 3F, a block diagram of capacitive buttons is shown in accordance with embodiments of the present technology. First and second capacitive buttons 205 and 210, respectively, are shown with input objects 340 and 345 (fingers are shown) concurrently disposed in sensing region of capacitive buttons 205 and 210. Input object 340, at sixth position 330, overlaps sensor electrode elements B<sub>1</sub> and C<sub>1</sub> of sensor electrodes B and C. Input object 345, at seventh position 335, covers an entire set of sensor electrode elements (that of second capacitive button 210). In other words, input object 345 is close to and overlaps sensor electrode elements A<sub>2</sub>, B<sub>2</sub>, and D<sub>2</sub> of sensor electrodes A, B, and D. With a case such as what is shown in FIG. 3F, the resulting indicia typically indicates user interaction with all four sensor electrodes A-D.

[0134] In many embodiments, this would result in all of the sensor electrodes A-D activated. In some embodiments, the controller may suppress or reject all button actuation possibilities, since having all sensor electrodes A-D activated may cause ambiguity about whether the user intended to actuate either or both of capacitive buttons 205 and 210. This is especially likely if the input objects 340 and 345 arrived substantially simultaneously in sixth position 330 and seventh position 335.

[0135] If the arrival of input objects 340 and 345 in sixth position 330 and seventh position 335 are sufficiently separated in time, then button actuation may have occurred earlier. In many embodiments, if input object 345 arrives at seventh position 335 substantially before the arrival of input object 340 at sixth position 330, then input object 345 may have caused actuation of second capacitive button 210 before input object 340 arrived at sixth position 330. However, in many embodiments, if input object 345 arrives at seventh position 335 substantially after the arrival of input object 340 at sixth position 330, then input object 345 may not have caused actuation of second capacitive button 210.

[0136] Further, in many embodiments, input object 340 would not cause actuation of first capacitive button 205 regardless of if input object 340 arrives at sixth position 330 before, after, or at the same time as input object 345 arriving at seventh position 335. In those embodiments, the interaction of input object 340, at sixth position 330, with first capacitive button 205 is not sufficient to result in actuation of first capacitive button 205.

[0137] Some embodiments may recognize that sensor electrodes B and perhaps C are experiencing an amount of interaction indicative of user input interacting with more than one sensor electrode element of the respective sensor electrodes. In such embodiments, the controller may suppress, reject, or ignore button actuation possibilities since such amounts of interaction may cause ambiguity about whether the user intended to actuate either or both of the capacitive buttons 205 and 210.

[0138] It should be noted that there would be less ambiguity for a scenario such as shown in FIG. 3F if sensor electrodes were not shared between first and second capacitive buttons 205 and 210. If sensor electrodes were not shared, and six distinct sensor electrodes are used (one for each sensor electrode element), then the indicia from the sensor electrodes would indicate that an input object is over part of first capacitive button 205 (not centered) and a second input object is over the second capacitive button 210 (likely centered). In such a case, the controller may allow actuation of the second capacitive button 210.

[0139] Of note, the present technology may also be utilized in conjunction with haptic feedback. A haptic feedback mechanism may be used to provide haptic feedback in response to activation of one or more sensor electrodes. Alternatively or in addition to providing feedback in response to sensor electrode activation, haptic feedback may be provided in response to button actuation. The timing of feedback may be provided on the “press” of a capacitive button, on the “release” of a capacitive button, or both. Also, different haptic feedback may be provided for activation of a sensor electrode vs. actuation of a button, for activation of different sensor electrodes, for actuation of different capacitive buttons, for press versus release, for suppressed button actuation (e.g. suppression in response to indicia from one or more disambiguating electrodes or other inputs), and the like. For example, the haptic feedback may be continuous or pulsed, or otherwise vary in magnitude or frequency. Haptic feedback may also be used in combination with other types of feedback, including visual and auditory feedback.

[0140] FIG. 9 is a flow diagram 900 of a method for determining actuation of a capacitive button, according to one embodiment. Thus, although flow diagram 900 shows three steps in a particular order, it is understood that different implementations may include different numbers of steps in other orders. Reference will be made to the capacitive sensing device 100 of FIGS. 1 and 2 in the description of flow diagram 900 in the discussion below for convenience. It is understood that the steps described below may be used with any of the different MSE capacitive button systems described herein.

[0141] In 905, in one embodiment, the method receives indicia from at least three distinct sensor electrodes comprising a capacitive button. In some implementations, this involves driving sensor electrodes to measure the amount of capacitive coupling of the sensor electrodes to an external object.

[0142] In some other implementations, 905 may involve emitting electrical signals using an emitter sensor electrode that is separate from the at least three distinct sensor electrodes. The electrical signals would be configured for effecting receipt of the indicia from the at least three distinct sensor electrodes.

[0143] In yet other implementations, 905 may involve emitting electrical signals using at least two of the at least three distinct sensor electrodes. As discussed above, using the same sensor electrodes to emit and receive means that the capacitive sensing device will likely time multiplex between different emitter-receiver combinations. The electrical signals emitted by the at least two of the at least three distinct sensor electrodes would be configured for effecting receipt of the indicia from the at least three distinct sensor electrodes.

[0144] In 910, in one embodiment, the method generates at least three electrode values from the indicia received from the at least three sensor electrodes.

[0145] In 915, in one embodiment, the method utilizes the at least three electrode values to determine actuation of the capacitive button. Actuation determination in 915 can involve direct examination of the electrode values themselves, such as by comparing at least one of the electrode values to an activation threshold value. For example, this can be done with an activation identification mechanism 220 that can indicate when indicia received from particular sensor electrodes exceed one or more activation thresholds, as discussed above. Further, the temporal characteristics of the electrode values may also be evaluated in determining button actuation.

[0146] Alternatively, actuation determination in **915** can involve indirect examination of the electrode values by calculating positional characteristics, such as with a positional characteristics analyzing unit **218**. For example, actuation determination may involve determining one or more position characteristics of one or more input objects with respect to the capacitive button. The positional characteristics may be determined for an instance in time or over a span of time. For example, position may be estimated using the electrode values.

[0147] Further, actuation determination in **915** can involve a combination of the approaches described above. For example, embodiments may use any combination of examining electrode values directly, evaluate changes to electrode values over time, determine and examine positional characteristics, evaluate temporal changes to positional characteristics, and the like.

[0148] As discussed above, the number and order of the parts of flow diagram **900** can change in specific implementations. For example, one or more additional blocks can be added to support distinguishing false actuations using a disambiguating electrode. Specifically, the capacitive sensing device **100** can include one or more disambiguating electrodes disposed proximate to the capacitive button, and the flow diagram **900** can include receiving indicia from such disambiguating electrode(s). The flow diagram **900** can further include generating one or more disambiguating values from the indicia received from the disambiguating electrode(s), and utilizing the disambiguating value(s) to determine a false actuation of the capacitive button.

[0149] As another example, the capacitive sensing device **100** can be configured to effect haptic feedback by directly controlling a haptic feedback system, or by providing an indication that haptic feedback should be provided. Flow diagram **900** can then be expanded to include effecting haptic feedback in response to a determination of button actuation.

[0150] Electronic systems can include and operate with MSE capacitive buttons. For example, an electronic system can include an output device capable of providing human-observable output, a plurality of capacitive buttons, and a controller. The plurality of capacitive buttons includes a substrate, a first set of sensor electrode elements disposed on the substrate, and a second set of sensor electrode elements disposed on the substrate. The first set of sensor electrode elements has at least three sensor electrode elements associated with distinct sensor electrodes of a plurality of sensor electrodes; that is, at least three sensor electrode elements of the first set do not share sensor electrodes with each other (however, if there are more than three sensor electrode elements in the first set, they may share sensor electrodes in some cases). Similarly, the second set of sensor electrode elements also has at least three sensor electrode elements that do not share sensor electrodes with each other. In some embodiments, one or more sensor electrode elements of the first set may be associated with the same sensor electrode(s) as one or more sensor electrode element of the second set. That is, the first and second sets of sensor electrode elements may share sensor electrodes.

[0151] The controller is coupled to the plurality of capacitive buttons and is configured to receive indicia from the plurality of sensor electrodes, to generate at least three electrode values using the indicia received from sensor electrodes associated with the first set of sensor electrode elements, and

to utilize the at least three electrode values to determine actuation of the first capacitive button.

[0152] The controller is further configured to effect human-observable output using the output device in response to actuation of the capacitive button. This can be done by controlling the output device, or indirectly by indicating to some other device that the output device should provide human-observable output.

[0153] The output device can be any appropriate device that outputs something observable by human senses such as sight, hearing, smell, taste, and touch. For example, the output device may provide visual output, auditory output, kinesthetic output, or a combination thereof. In some embodiments, the output device is a sound device, and the controller causes one or more sounds using the sound device. In other embodiments, the output device is a force feedback device, and the controller causes haptic feedback using the force feedback device.

[0154] The foregoing descriptions of specific embodiments have been presented for purposes of illustration and description. They are not intended to be exhaustive or to limit the present technology to the precise forms disclosed, and obviously many modifications and variations are possible in light of the above teaching. The embodiments were chosen and described in order to best explain the principles of the present technology and its practical application, to thereby enable others skilled in the art to best utilize the present technology and various embodiments with various modifications as are suited to the particular use contemplated. It is intended that the scope of the present technology be defined by the claims appended hereto and their equivalents.

What is claimed is:

1. A capacitive button arrangement comprising:
  - a first capacitive button comprising:
    - a first set of sensor electrode elements, said first set of sensor electrode elements having at least three sensor electrode elements associated with distinct sensor electrodes, wherein said first set of sensor electrode elements is configured to enable the generation of at least three electrode values for determining actuation of said first capacitive button; and
    - a second capacitive button disposed noncontiguously with respect to said first capacitive button, said second capacitive button comprising:
      - a second set of sensor electrode elements, said second set of sensor electrode elements having at least three sensor electrode elements associated with distinct sensor electrodes, wherein said second set of sensor electrode elements is configured to enable the generation of at least three electrode values for determining actuation of said second capacitive button.
  2. The capacitive button arrangement of claim 1 further comprising:
    - a tactile feature disposed proximate said first capacitive button, said tactile feature for providing tactile feedback for said first capacitive button.
    3. The capacitive button arrangement of claim 1 wherein at least one of said distinct sensor electrodes associated with said at least three sensor electrode elements of said first set of sensor electrode elements is capable of emitting electrical signals.
    4. The capacitive button arrangement of claim 1 wherein at least one of said distinct sensor electrodes associated with

said at least three sensor electrode elements of said first set is capable of both emitting and receiving electrical signals.

5. The capacitive button arrangement of claim 1 wherein said second capacitive button is disposed noncontiguously with respect to said first capacitive button by spacing said first set of sensor electrode elements from said second set of sensor electrode elements by no less than one-half of a finger width.

6. The capacitive button arrangement of claim 1 further comprising:

a disambiguating electrode disposed proximate said first set of sensor electrode elements, said disambiguating electrode configured to enable distinguishing of user input intended to actuate said first capacitive button from user input not intended to actuate said first capacitive button.

7. The capacitive button arrangement of claim 1, wherein said first set of sensor electrode elements has no more than four sensor electrode elements.

8. The capacitive button arrangement of claim 1 wherein at least two sensor electrode elements of said first set of sensor electrode elements are physically interdigitated with each other.

9. The capacitive button arrangement of claim 1 wherein a sensor electrode element of said first set of sensor electrode elements and a sensor electrode element of said second set of sensor electrode elements are associated with a same sensor electrode.

10. The capacitive button arrangement of claim 9 wherein said sensor electrode element of said first set of sensor electrode elements is physically closer to said sensor electrode element of said second set of sensor electrode elements than to any other sensor electrode element of said second set of sensor electrode elements.

11. The capacitive button arrangement of claim 9 wherein said sensor electrode element of said first set of sensor electrode elements is physically farther away from said sensor electrode element of said second set of sensor electrode elements than to any other sensor electrode element of said second set of sensor electrode elements.

12. The capacitive button arrangement of claim 9 wherein said sensor electrode element of said first set of sensor electrode elements and said sensor electrode element of said second set of sensor electrode elements are disposed on a same side of said capacitive button arrangement.

13. The capacitive button arrangement of claim 1 wherein said first capacitive button has a size that enables actuation by a human digit.

14. The capacitive button arrangement of claim 1 wherein said sensor electrode elements of said first set of sensor electrode elements are disposed symmetrically.

15. The capacitive button arrangement of claim 1, wherein at least two sensor electrode elements of said first set of sensor electrode elements have centers that are substantially equidistant from a center of said first capacitive button.

16. The capacitive button arrangement of claim 1 wherein said first capacitive button has a circular shape, and wherein said sensor electrode elements of said first set of sensor electrode elements occupy substantially equal sectors of said circular shape.

17. The capacitive button arrangement of claim 1 wherein said first capacitive button has a central region, and wherein said sensor electrode elements of said first set of sensor electrode elements are disposed outside of said central region.

18. The capacitive button arrangement of claim 1 wherein said first capacitive button has rectilinear portions, and wherein said sensor electrode elements of said first set of sensor electrode elements have angular sections.

19. The capacitive button arrangement of claim 1 wherein said sensor electrode elements of said first set of sensor electrode elements have substantially equal areas.

20. The capacitive button arrangement of claim 1 further comprising:

a third capacitive button comprising:

a third set of sensor electrode elements disposed between said first set of sensor electrode elements and said second set of sensor electrode elements, said third set of sensor electrode elements having at least three sensor electrode elements associated with distinct sensor electrodes, wherein no sensor electrode element of said third set of sensor electrode elements is associated with any sensor electrodes associated with any sensor electrode element of said first set of sensor electrode elements, and wherein no sensor electrode element of said third set of sensor electrode elements is associated with any sensor electrodes associated with any sensor electrode element of said second set of sensor electrode elements.

21. A capacitive sensing device comprising:

a substrate;

a first capacitive button coupled to said substrate, said first capacitive button comprising:

a first set of sensor electrode elements disposed on said substrate, said first set of sensor electrode elements having at least three sensor electrode elements associated with distinct sensor electrodes of a plurality of sensor electrodes;

a second capacitive button coupled to said substrate, said second capacitive button comprising:

a second set of sensor electrode elements disposed on said substrate, said second set of sensor electrode elements having at least three sensor electrode elements associated with distinct sensor electrodes of said plurality of sensor electrodes; and

a controller coupled to said first capacitive button and said second capacitive button, said controller configured to receive indicia from said plurality of sensor electrodes, to generate at least three electrode values using indicia received from sensor electrodes associated with said first set of sensor electrode elements, and to utilize said at least three electrode values to determine actuation of said first capacitive button.

22. The capacitive sensing device of claim 21 wherein at least one of said distinct sensor electrodes associated with said at least three sensor electrode elements of said first set of sensor electrode elements is capable of emitting electrical signals.

23. The capacitive sensing device of claim 21, wherein said first capacitive button has no more than four sensor electrode elements.

24. The capacitive sensing device of claim 21, wherein sensor electrode elements of said first set of sensor electrode elements have a symmetric layout.

25. The capacitive sensing device of claim 21, wherein sensor electrode elements of said first set of sensor electrode elements have substantially equal areas.

26. The capacitive sensing device of claim 21, wherein a sensor electrode element of said first set of sensor electrode

elements and a sensor electrode element of said second set of sensor electrode elements are associated with a same sensor electrode.

27. The capacitive sensing device of claim 21 wherein said first capacitive button has a size configured to be actuated by a human finger.

28. A method for determining actuation of a capacitive button having at least three sensor electrode elements associated with at least three distinct sensor electrodes, said method comprising:

- receiving indicia from said at least three distinct sensor electrodes comprising said capacitive button;
- generating at least three electrode values from said indicia; and
- utilizing said at least three electrode values to determine actuation of said capacitive button.

29. The method for determining actuation of a capacitive button as recited in claim 28, wherein said utilizing said at least three electrode values to determine actuation of said capacitive button comprises:

- comparing at least one of said at least three electrode values to an activation threshold value.

30. The method for determining actuation of a capacitive button as recited in claim 28, wherein said utilizing said at least three electrode values to determine actuation of said capacitive button comprises:

- determining a position of an input object with respect to said capacitive button.

31. The method for determining actuation of a capacitive button as recited in claim 28 further comprising:

- receiving indicia from a disambiguating electrode disposed proximate to said capacitive button;
- generating a disambiguating value from said indicia from said disambiguating electrode; and
- utilizing said disambiguating value to determine a false actuation of said capacitive button.

32. The method for determining actuation of a capacitive button as recited in claim 28 further comprising:

- emitting electrical signals using at least one of said at least three distinct sensor electrodes, said electrical signals for effecting said indicia from said at least three distinct sensor electrodes.

33. The method for determining actuation of a capacitive button as recited in claim 28 further comprising:

emitting electrical signals using at least two of said at least three distinct sensor electrodes, said electrical signals for effecting said indicia from said at least three distinct sensor electrodes.

34. An electronic system comprising:

an output device capable of providing human-observable output;

a plurality of capacitive buttons comprising:

- a substrate;
- a first set of sensor electrode elements disposed on said substrate, said first set of sensor electrode elements having at least three sensor electrode elements associated with distinct sensor electrodes of a plurality of sensor electrodes;
- a second set of sensor electrode elements disposed on said substrate, said second set of sensor electrode elements having at least three sensor electrode elements associated with distinct sensor electrodes of said plurality of sensor electrodes; and

a controller coupled to said plurality of capacitive buttons, said controller configured to receive indicia from said plurality of sensor electrodes, to generate at least three electrode values using indicia received from sensor electrodes associated with said first set of sensor electrode elements, to utilize said at least three electrode values to determine actuation of said first capacitive button, and to effect human-observable output using said output device in response to actuation of said first capacitive button.

35. The electronic system of claim 34, wherein said output device capable of providing human-observable output is a sound device, and wherein

said controller is configured to effect human-observable output using said output device in response to actuation of said first capacitive button by producing a sound using said sound device in response to actuation of said first capacitive button.

36. The electronic system of claim 34, wherein said output device capable of providing human-observable output is a force feedback device, and wherein

said controller is configured to effect human-observable output using said output device in response to actuation of said first capacitive button by providing haptic feedback using said force feedback device in response to actuation of said first capacitive button.

\* \* \* \* \*