



US 20090151288A1

(19) **United States**
(12) **Patent Application Publication**
Kalkanoglu et al.

(10) **Pub. No.: US 2009/0151288 A1**
(43) **Pub. Date: Jun. 18, 2009**

(54) **METHOD OF MAKING A SHINGLE AND SHINGLE MADE THEREBY**

(75) Inventors: **Husnu M. Kalkanoglu**, Swarthmore, PA (US); **Robert L. Jenkins**, Honey Brook, PA (US); **Richard Krause**, Collegeville, PA (US); **Joseph Quaranta**, Yardley, PA (US); **Kermit Stahl**, North Wales, PA (US)

Correspondence Address:
PAUL AND PAUL
2000 MARKET STREET, SUITE 2900
PHILADELPHIA, PA 19103 (US)

(73) Assignee: **CERTAIN TEED CORPORATION**, Valley Forge, PA (US)

(21) Appl. No.: **12/389,452**

(22) Filed: **Feb. 20, 2009**

Related U.S. Application Data

(62) Division of application No. 10/544,567, filed on Aug. 19, 2005, now Pat. No. 7,510,622, filed as application No. PCT/US05/16063 on May 9, 2005.

Publication Classification

(51) **Int. Cl.**
E04D 1/00 (2006.01)
E04D 1/26 (2006.01)
(52) **U.S. Cl.** 52/554

(57) **ABSTRACT**

A method of making a shingle and the shingle made in accordance with such method are provided, in which a shingle-forming layer of shingle material has a plurality of marks applied thereto prior to or after application of decorative granules to its tab region, and wherein the locations of the marks are sensed by a sensor, that then activates and controls the operation and placement of various shingle-completion steps as a function of the placement of the marks.

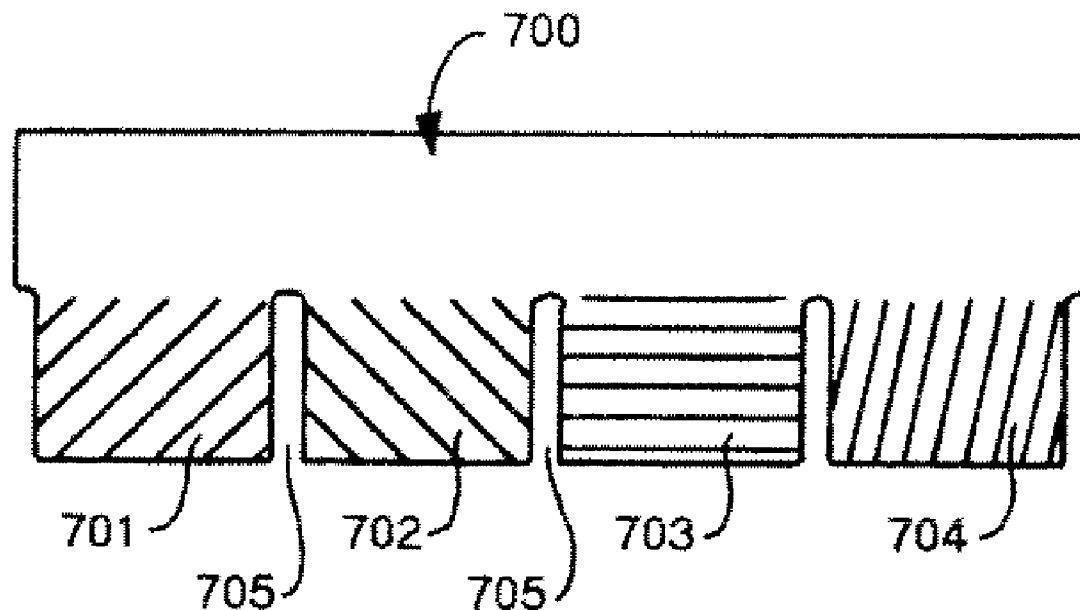

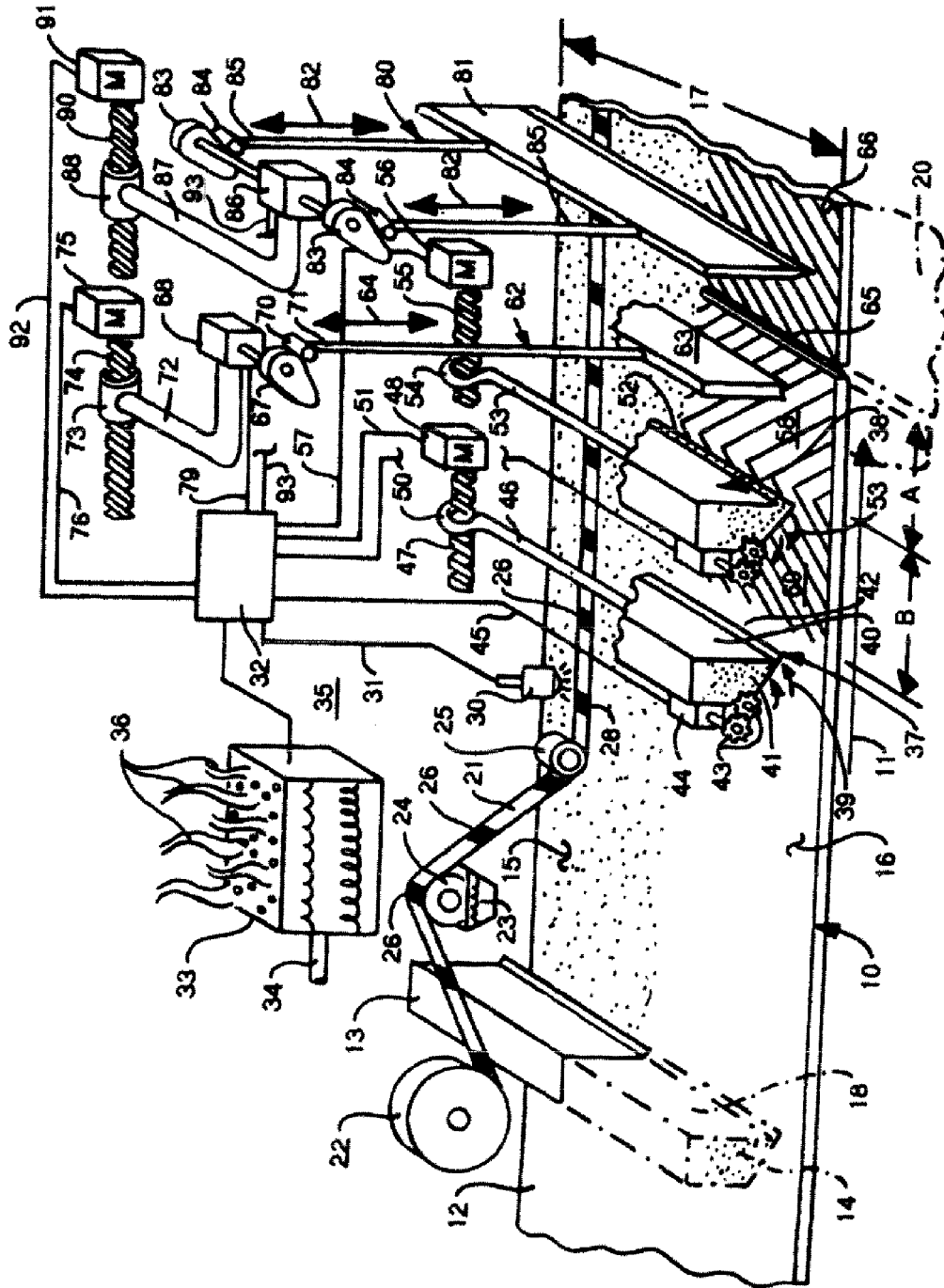

Fig. 1

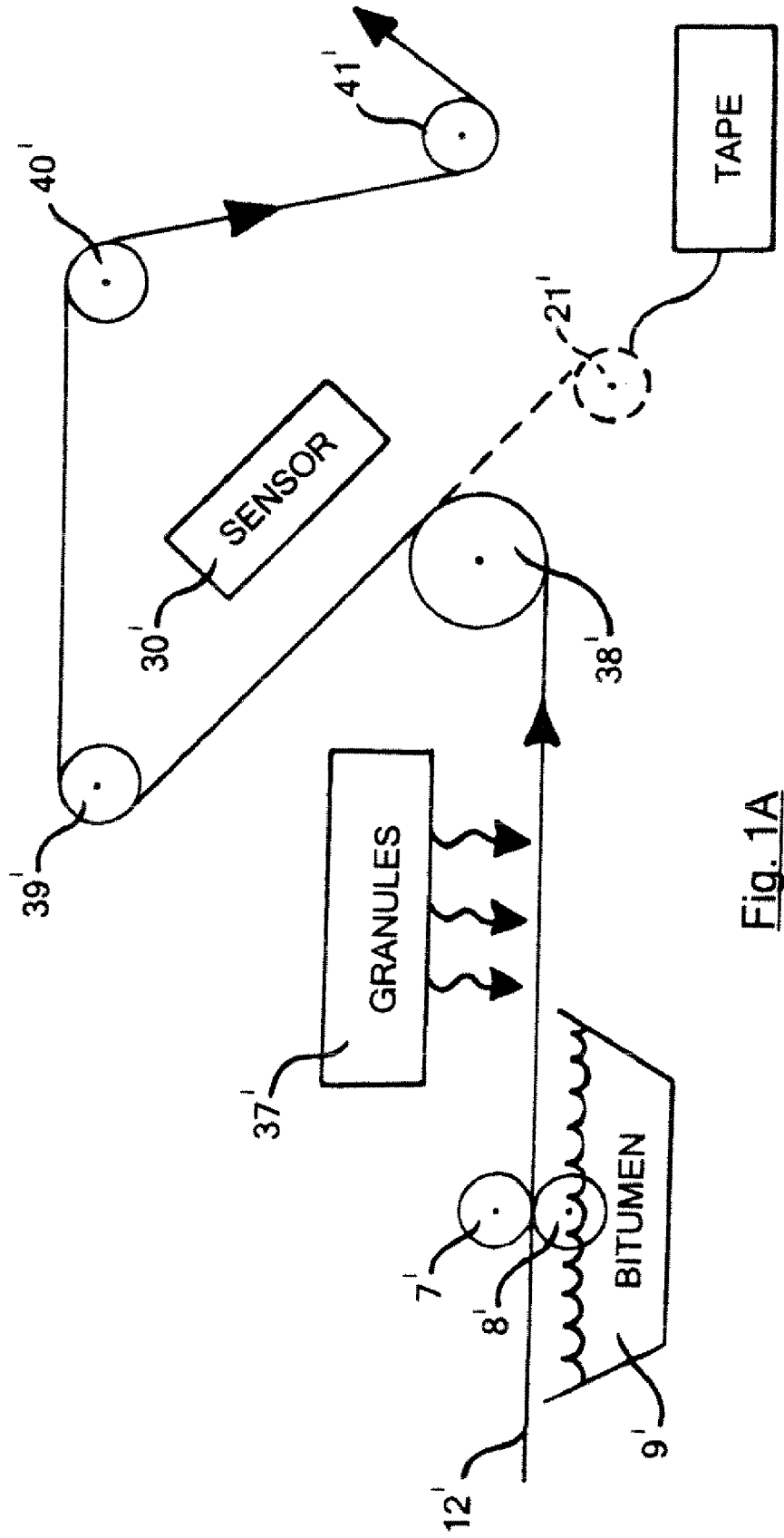

Fig. 1A

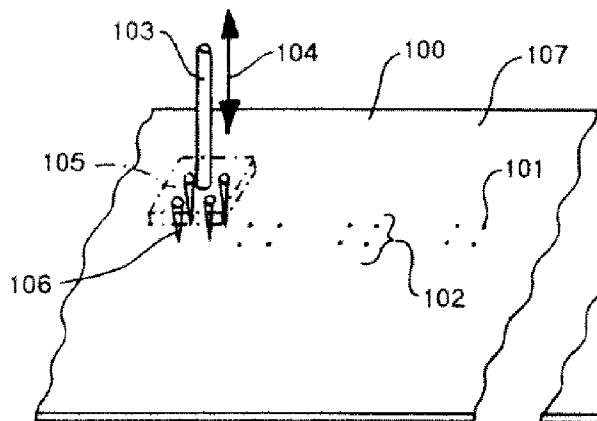

Fig. 2

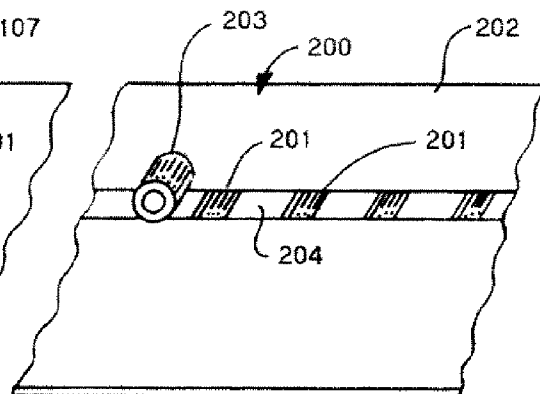

Fig. 3

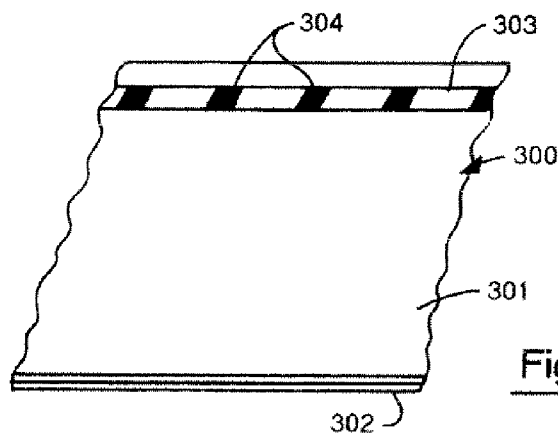

Fig. 4

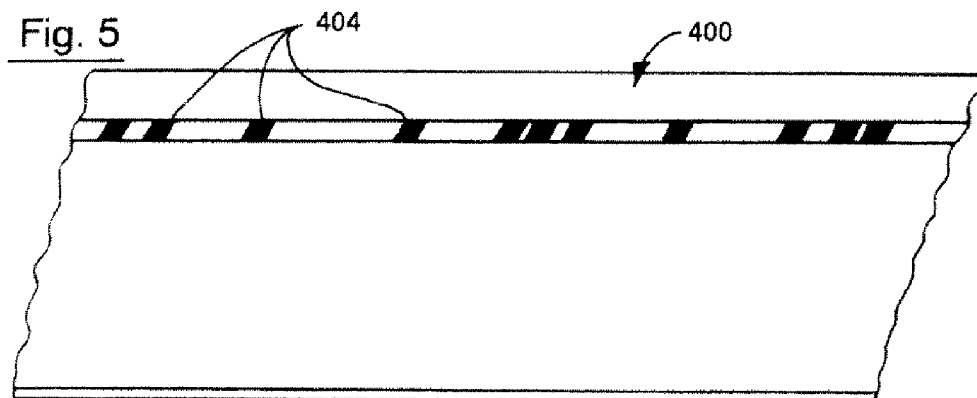

Fig. 5

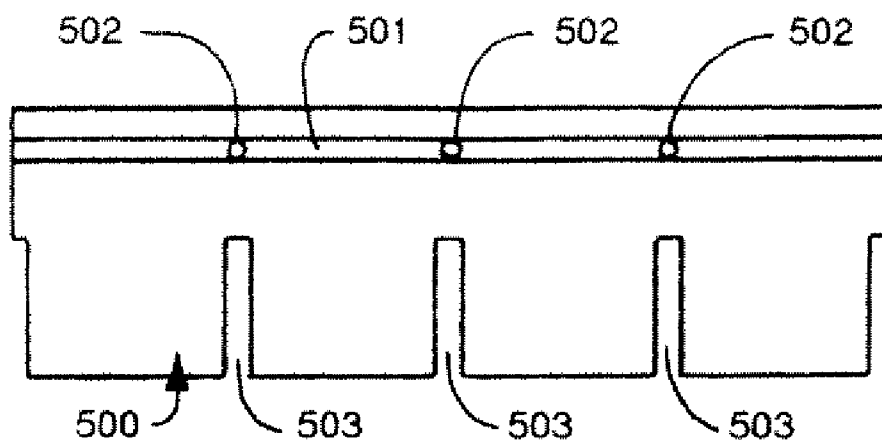

Fig. 6

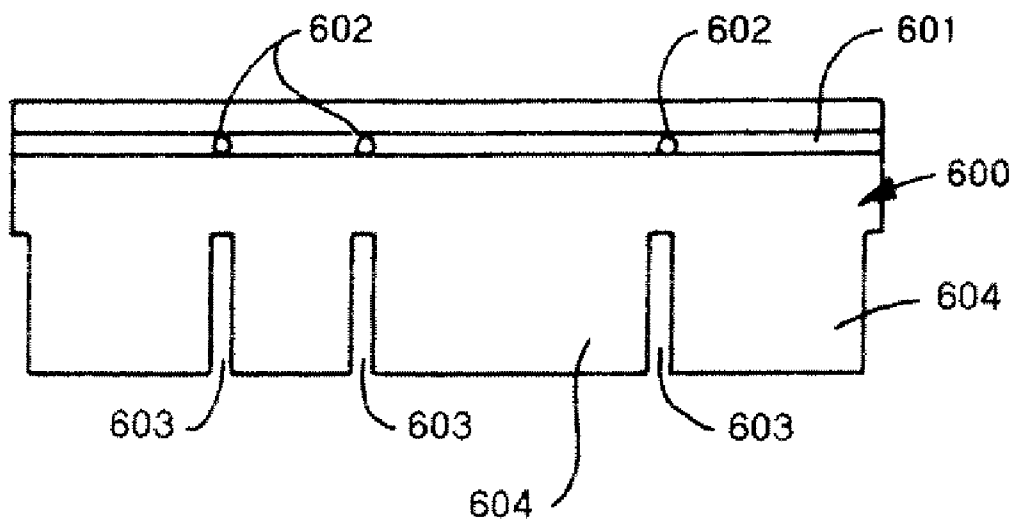

Fig. 7

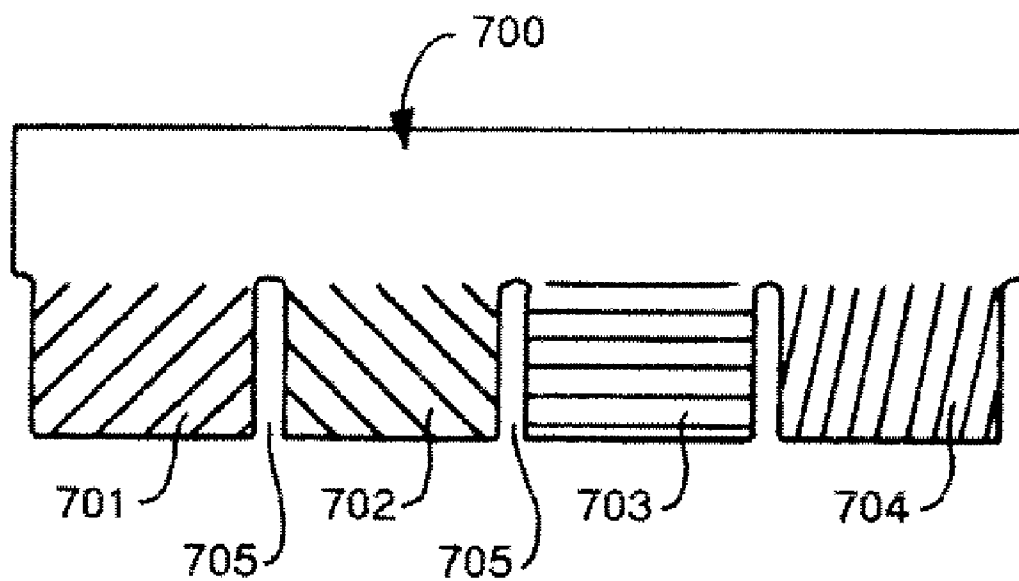

Fig. 8

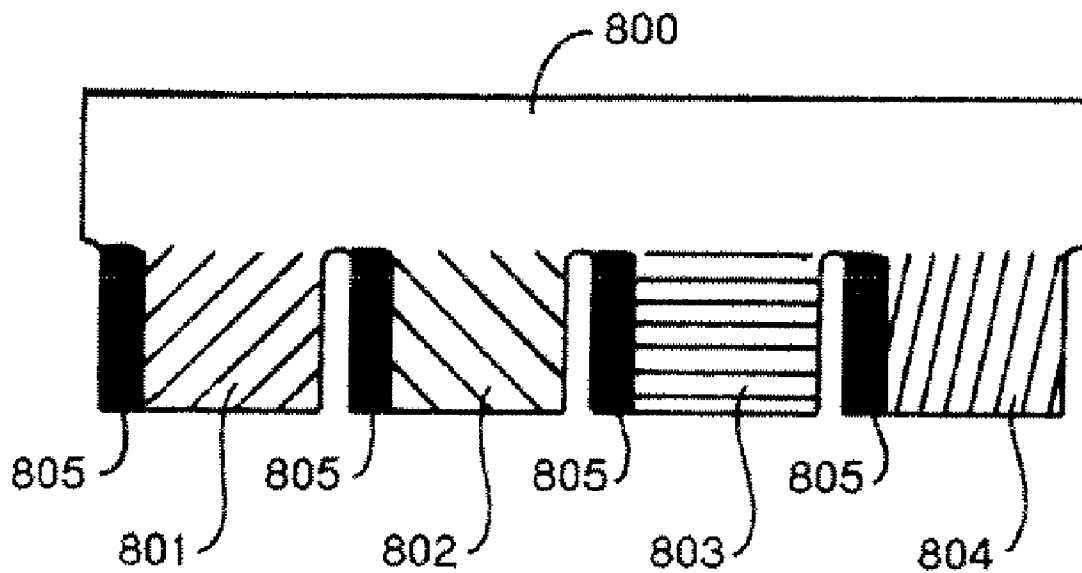

Fig. 9

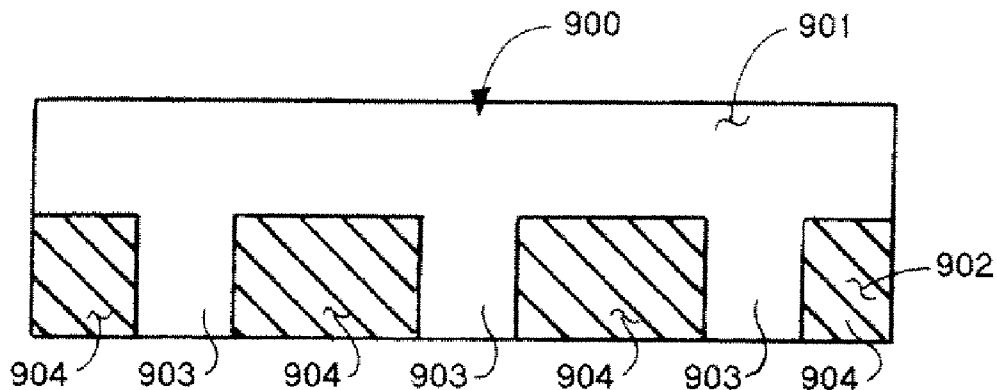

Fig. 10

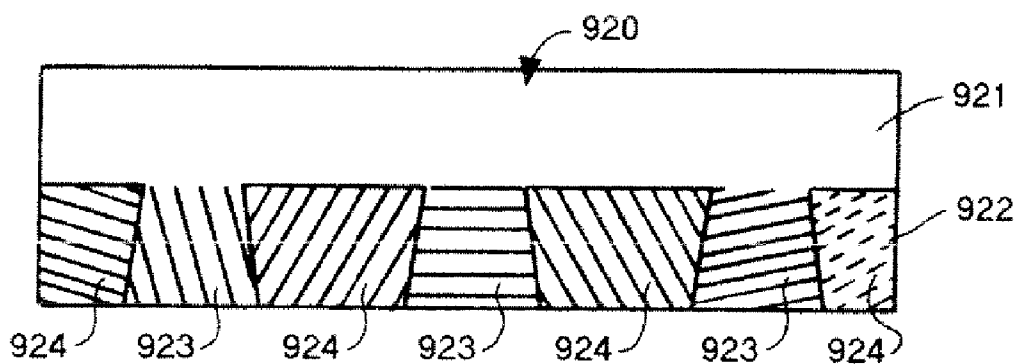

Fig. 11

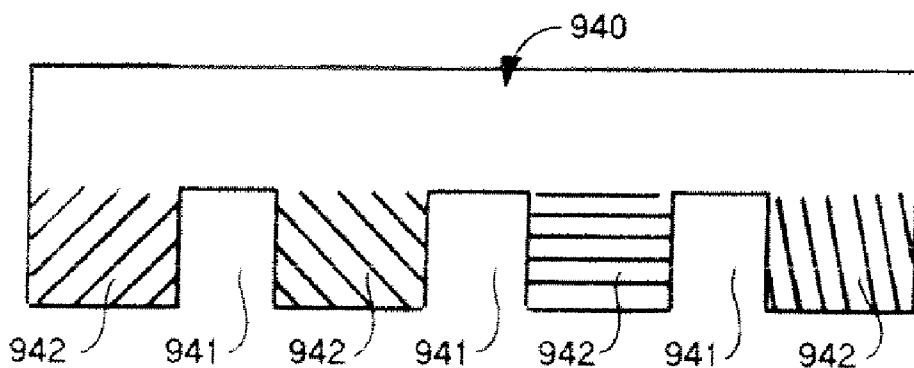

Fig. 12

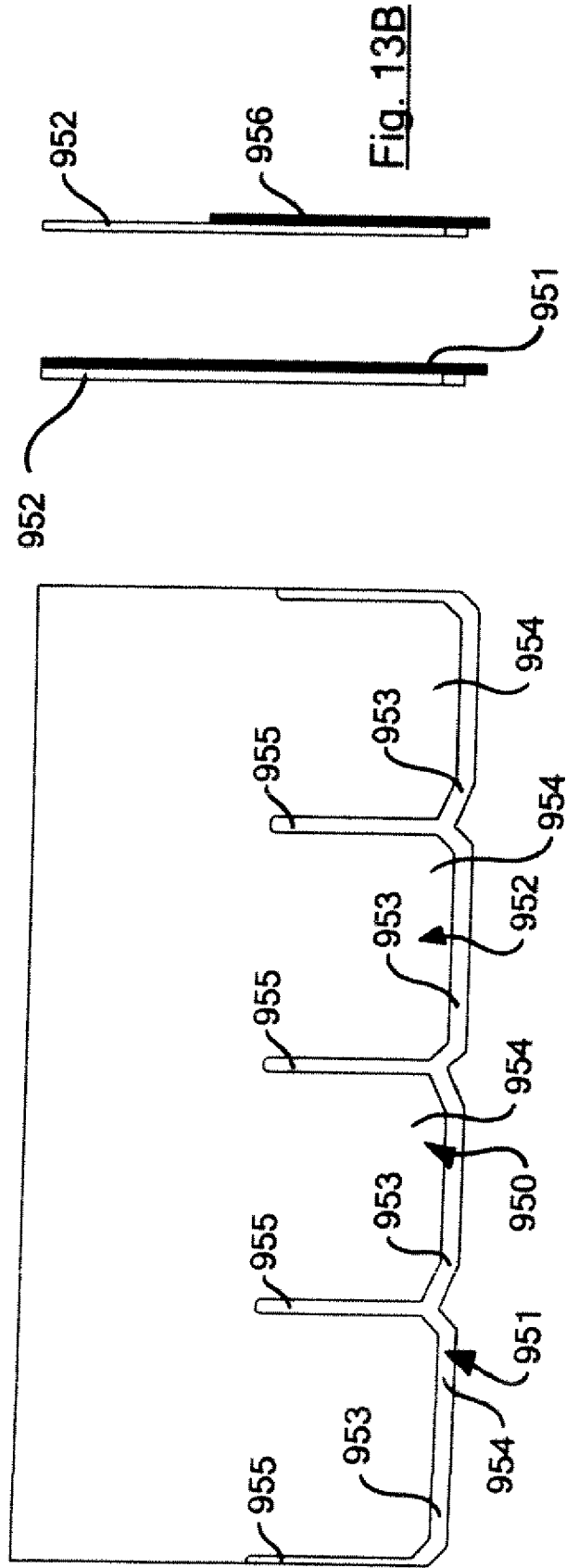

Fig. 13A

Fig. 13

METHOD OF MAKING A SHINGLE AND SHINGLE MADE THEREBY

BACKGROUND OF THE INVENTION

[0001] Endeavors have been made for many years to manufacture asphalt shingles having appearances of natural materials, such as slate, tile, and cedar shakes.

[0002] In the course of manufacture of such shingles, it is known to use a mat, generally of fiberglass construction, impregnated with an asphalt or other bitumen material, and then to apply granules to the shingle, to adhere to the bitumen material.

[0003] When shingles are to be laid-up on a roof, with each successive course overlying in part, an underlying course of shingles, it is generally not considered necessary that the same granules be applied both to the butt (or head lap) region of the shingle as will be applied to the tab region of the shingle, because the butt region of the shingle will be covered by one or more next-overlying shingles, whereas the tab region of a shingle will remain visible.

[0004] Consequently, when decorative granules are to be applied to a shingle, they are generally only applied to a tab region, because that is the region of the shingle that will be visible when the shingle is laid-up on a roof.

[0005] Various techniques have been developed for making the tab regions of shingles decorative, often to resemble natural materials, as mentioned above.

[0006] Often, different decorative effects are sought to be applied to different tabs of the same multi-tab manufactured shingle, such that each tab can simulate an individual, tile, piece of slate, cedar shake, etc.

SUMMARY OF THE INVENTION

[0007] The present invention is directed to creating decorative manufactured shingles, wherein various decorative effects, such as decorative granule application, slot or other space in between adjacent tabs, shingle cut-off between adjacent shingles, and shingle expansion/contraction, or any of the above functions can be controlled with great precision, by first marking the layer of shingle-forming material, prior to, during or after doing any of the decorative granule application, slot or spacing formation, or cut-off functions, and then sensing the mark(s) and then controlling with precision the placement of such subsequent functions, in an automatic manner, such that the desired shingle is manufactured with precision. That is, some operations to produce a shingle could already have occurred prior to marking the shingle-forming material to control other, subsequent operations in the manufacture of the shingle.

[0008] The markings can be uniformly spaced apart, to create a predetermined repeatability of features in the shingles, or they can be unevenly spaced apart to provide a predetermined appearance of non-repeatability, as desired, for example by printing or marking on a portion of the moving web or shingle-forming layer, or having a coating or tape applied to the shingle-forming layer with a printer, such as an inkjet printer online, or by any other means.

[0009] The markings can be provided in any of a number of manners, such as by applying a tape to the shingle-forming layer early in its manufacture, by applying a barcode to the shingle-forming layer, directly or via a tape, by applying holes (which include punctures or notches), or any other form of marking as may be desired.

[0010] Accordingly, it is an object of this invention to provide a novel method of manufacturing a shingle, wherein various decorative effects can be achieved with precision, by controlling the exact application of such decorative effects by sensing a predetermined mark on a shingle-forming layer, prior to application of decorative effects.

[0011] It is another object to accomplish the above object, wherein one such decorative effect is the application of decorative granules in the tab region of the shingle-forming layer.

[0012] It is another object of this invention to accomplish the above objects wherein the decorative effects include cutting slots or other spaces in the tab region of the shingle-forming layer to form spaced-apart tabs.

[0013] It is a further object of this invention to accomplish the above objects, wherein one such decorative effect is the cutting of the shingle-forming layer into separate shingles of predetermined length.

[0014] It is yet another object of this invention to accomplish the above objects, wherein one such decorative effect is controlling the expansion and/or contraction of the shingle-forming layer prior to cutting the shingle-forming layer into separate shingles, by controlling the humidity in the shingle manufacturing environment. Such is desirable for dimensional stability of a paper or polymer based or tape appliqué bearing a marking scheme prior to application to the shingle-forming layer.

[0015] Other objects and advantages of the present invention will be readily apparent to those skilled in the art upon a reading of the following brief descriptions of the drawing figures, the detailed descriptions of the preferred embodiments, and the appended claims.

BRIEF DESCRIPTIONS OF THE DRAWING FIGURES

[0016] FIG. 1 is a top perspective view of a schematic illustration of the manufacture of shingles by the application, of various decorative effects to a shingle-forming layer as it is being conveyed along a longitudinal path, and wherein marks are applied to the shingle-forming layer prior to application, of decorative effects thereto, such marks being applied to the shingle-forming layer in the form of a tape that is applied thereto.

[0017] FIG. 1A is a diagrammatic illustration of the placement of a sensor onto the shingle-forming layer after application of the marking feature, with the mark position being responsive to something that has already occurred, for triggering or controlling subsequent events.

[0018] FIG. 2 is a top perspective view, fragmentally illustrating a portion of a shingle-forming layer having sensible marks applied thereto in the form of holes or punctures.

[0019] FIG. 3 is an illustration similar to that of FIG. 2, but wherein barcode(s) are applied to the shingle-forming layer, to comprise the marks.

[0020] FIG. 4 is an illustration similar to that of FIGS. 2 and 3, but wherein a tape having marks thereon similar to those of FIG. 1 is applied to the shingle-forming layer, and wherein the shingle that is made is a multi-layer shingle.

[0021] FIG. 5 is an illustration similar to that of FIGS. 2 and 3, but wherein the marks are applied in the form of a tape, and which are seemingly randomly disposed on the tape, to yield an appearance of non-repeatability of features in the completed shingle.

[0022] FIG. 6 is a top plan view of a shingle in accordance with this invention, wherein the marks appear on a tape that is

applied to the shingle, and are synchronized above the placement of slots between adjacent tabs of the shingle.

[0023] FIG. 7 is an illustration similar to that of FIG. 6, but wherein the marks and tab-separating slots are seemingly randomly located along the length of the shingle.

[0024] FIG. 8 is a top view of a shingle made in accordance with this invention, wherein four distinct decorative effects are shown in the tab regions of the shingle, with the tab regions being spaced apart by slots.

[0025] FIG. 9 is an illustration similar to that of FIG. 8, but wherein shade lines are illustrated adjacent the left edge of each tab of the shingle.

[0026] FIGS. 10, 11 and 12 are top plan views of different shingles made in accordance with this invention, wherein different aesthetic effects are realized.

[0027] FIGS. 13, 13A and 13B represent a multi-layer shingle (FIG. 13) wherein a full backing or posterior layer is shown in FIG. 13A, and wherein a partial backing or posterior layer is shown in FIG. 13B

DETAILED DESCRIPTIONS OF THE PREFERRED EMBODIMENTS

[0028] Referring now to the drawings in detail reference is first made to FIG. 1, wherein a shingle-forming layer 10 is generally illustrated as being conveyed from left to right, in the longitudinal direction of the arrow 11. It will be understood that the shingle-forming layer is being conveyed on a conveyor, generally of the roller type (not shown), and that the layer 10 is fragmentally illustrated. The layer 10 is comprised of a base mat of reinforcement material, preferably fiberglass, although the same can be an organic material, and wherein the reinforcement material is already impregnated with an asphalt or other bitumen material.

[0029] The bitumen material also appears on the surface 12, to receive granules dispensed therefrom from a granule applicator 13. The granule applicator 13 has granules 14 therein which will normally dispense lower grade granules, that can be reclaimed granules (also called headlap granules) therefrom, into a butt or headlap region 15 of the shingle-forming layer, which region 15 is above a tab region 16 of the shingle-forming layer, as shown in FIG. 1.

[0030] Generally, the granules 14 dispensed from the granule dispenser or applicator 13 are dark in color, although they can, if desired, be of any other shade.

[0031] Because the granules dispensed from the applicator 13 are principally dispensed into the butt or headlap region 15, the applicator 13 need not be of the full width 17 of the shingle-forming layer, although, if desired, the applicator 13 can be of full width as shown by the phantom extension portion 18 thereof, if it is desired to initially, or at any other time, dispense headlap granules also into the tab region of the shingle-forming layer 12.

[0032] It will be understood that, in the manufacture of a shingle-forming layer 12 in accordance with this invention, the shingle-forming layer may be manufactured in the form of a pair of side-by-side shingle-forming layer portions 12 and 20, with the portion 20 being fragmentally shown in phantom in FIG. 1, such that the layer portions 12 and 20 are simultaneously formed, in accordance with that portion of the disclosure of parallel, shingle-forming layers as manufactured according to U.S. Pat. No. 6,212,843, the complete disclosure of which is herein incorporated by reference.

[0033] For the purposes of simplifying the presentation of the invention in accordance with this application, hereafter, only a single shingle-forming layer 12 will be discussed.

[0034] It will also be understood that it is not essential that headlap granules 14 be applied at all, in accordance with this invention, prior to the application of decorative granules as will hereinafter be discussed, and prior to the application of slots and shingle cut-off, although the application of headlap granules 34 in the headlap or butt region 15 of the shingle is preferred.

[0035] Marks are applied to the shingle-forming layer 12, preferably in the butt region 15, and such marks may be applied by applying a tape 21, supplied from a roll 22 or the like, which tape becomes attached to a preferably upper surface of the shingle-forming layer 12 by means of an adhesive 23 applied from an adhesive applicator 24 of a roller or like type, as shown in FIG. 1, such that the lower surface of the tape adhesively sticks to the upper surface of the tab portion 15 of the shingle-layer 12, and preferably onto headlap granules that are applied in the butt region 15 of the shingle-forming layer 12.

[0036] A roller 25 or the like can urge the tape 21 into contact with the upper surface of the butt region 15 of the shingle-forming layer 12, as shown.

[0037] The tape 21 has a plurality of marks 26 thereon, which, in the embodiment shown in FIG. 1, can be darkened areas of the tape 21, which can be evenly spaced apart as shown to provide a predetermined repeatability of features of other shingle-completion steps that will subsequently be discussed, or which darkened areas 26 may, if desired, be unevenly spaced apart from each other to provide a predetermined non-repeatability of features of shingle-completion steps that will subsequently be discussed.

[0038] A sensor 30 is provided, for sensing the presence of marks 26 passing therebeneath and communicating, in response thereto, via a signal line 31, to a computer or other controller 32, preferably of the microprocessor type. In the case of a wireless transmission of the signal from the sensor 30 to the controller 32, a physical signal line 31 would not be necessary.

[0039] It will be understood that the sensor 30 may take on various forms, such as a lightness or darkness detector, a metal or magnetic detection device, a barcode reader, an infrared detection device, a hole detection device, a photocell, a CCD array image reader or any other form of detection device, many types of which are well known in the art, which can detect some difference caused by a mark of various types such as that 26, passing therebeneath.

[0040] Once the sensor 30 detects the presence of a mark 26 passing therebeneath, it can then control the application of various other shingle-completion features, which control is exercised subsequently to the sensing of marks 26 by the sensor 30.

[0041] One such feature that can be controlled is the humidity environment in which the shingle-forming layer 12 continues to pass in the direction of the arrow 11. To this end, the controller 32 is operatively connected to a humidifier 33, supplied with water via a line 34, in the manufacturing environment 35 in which the shingles are being made, such that moisture 36, provided from the humidifier 33 is added to the environment 35 in amounts as determined by the controller 32. By proper control of the humidity in the environment 35, any expansion and/or contraction of the layer 12 as shingles

are being formed therefrom can be controlled with precision. Humidity control facilitates dimensional stability of the marking tape 21, as well.

[0042] In FIG. 1 there are also shown a pair of decorative granule applicator systems 37 and 38. While only two such systems 37 and 38 are shown, it will be apparent that any desired number of such systems may be used, in accordance with the present invention.

[0043] The applicator system 37 includes a decorative granule applicator 40 fragmentally illustrated, having granules 41 therein, with an openable bottom 42 controlled in some manner within the skill of those in this art, but shown closed in the direction of arrows 39. In the particular embodiment shown, the openable bottom 42 is shown as being controlled by a pair of gears 43 controlled by a gear box 44, that, in turn, is electrically controlled via control line 45 from the controller 32. It will be apparent that other forms of granule application may be utilized other than that shown for the system 37, and that the discharge from openable bottom 42 may be replaced by any other means of discharge. Similarly, the gearing and gear box 43, 44, respectively represents only one representative means of controlling the application of granules from the applicator system 37.

[0044] Thus, the dropping of decorative granules 41 is controlled from the controller 32, that in turn responds to the sensor 30 detecting marks such as those 26.

[0045] The decorative granule applicator 37 is also controlled as to its longitudinal position leftward or rightward, in order to control the precise placement of dropping of granules therefrom onto the upper surface of the shingle-forming layer 12. Thus, variations leftward and rightward in the positioning of the applicator 40 can take place in that the applicator 40 is connected via positioning rod 46 to a means for moving the applicator 40 leftward and rightward. One such means can be the use of a worm gear 47, rotatable as determined by a motor 48 that controls the rotation of the worm screw, and by which a bearing 50 that rides along the worm gear 47 is moved leftward and rightward upon rotation of the motor 48, and with the rotation of the motor 48 being controlled via control line 51 from the controller 32, which, again, is, in turn, responsive to the detection of marks 26 by the sensor 30.

[0046] The decorative granule system 38, likewise is adapted for dropping decorative granules on the upper surface of the shingle-forming layer 12, by opening openable bottom 52 in the direction of the arrows 53.

[0047] In a similar manner to the system 37, the system 38 is operated via a positioning rod 53, a bearing 54, a worm gear 55, motor 56, control line 57, and the controller 32 upon sensing of marks 26 by the sensor 30.

[0048] It will thus be seen that the granule applicator systems 37 and 38 are shown to have accurately deposited granules of different decorative appearances that start and stop as viewed longitudinally, with precision, as shown by the dimensions A and B for the tab-forming zones 58 and 60, respectively.

[0049] The manner in which the sensor 30, by sensing marks 26 and operating to control the cutting of slots or other spaces in the tab region 16 of the shingle-forming layer 12, to form spaced-apart tabs will now be discussed. The slot or other space-forming system 62 comprises a slot or space cutter 63, positionable into and out of contact with the shingle-forming layer 12, and positionable longitudinally for precise placement of the slot or other space that is to be cut. In the embodiment shown, the cutter 63 is adapted to be moved

upwardly or downwardly in the direction of the double-headed arrow 64, to form the slot 65 or other space between tab zones 58 and 66 in FIG. 1. One mechanism for moving the cutter 63 to form the slot 65 or other space, is in the form of a cam 67, driven via a drive mechanism 68, controlled via control line 79 from controller 32 and with the cam 67 operating against a cam follower 70 that drives a rod 71 carried thereby upwardly or downwardly, as shown in FIG. 1 to cut a slot 65 or other space between adjacent tabs.

[0050] The entire system 62 can also be moved leftwardly or rightwardly as shown in FIG. 1 in that it is mounted to an "L"-shaped bar 72 that, in turn is carried by a bearing 73 that is mounted on a worm gear 74, such that upon rotation of the worm gear 74, the bearing 73 moves the system 62 leftward or rightward, and with the worm gear 74 being controlled by the motor 75 that is connected via control line 76 to the controller 32, such that upon detection of marks 26 by the sensor 30, the system 62 can be placed leftward or rightward, in the precise position desired and can be activated to engage the shingle-forming layer and cut a slot 65 or other space between tab zones to form tabs such as that 65 of FIG. 1.

[0051] A system 80 will now be discussed for cutting the shingle-forming layer 12 into discrete shingles. The system 80 as shown in FIG. 1, includes a shingle cutter 81 adapted for movement upwardly or downwardly as shown by the double-headed arrow 82. Such vertical movement can be controlled by a plurality of cams 83 engaged with cam followers 84 that in turn operate drive rods 85 that move the cutter 81 upwardly or downwardly as driven by the cam drive mechanism 86. The drive mechanism 86 is, in turn, controlled for movement of the cutoff system 80 leftwardly or rightwardly in a manner similar to that provided for the system 62, in that an "L"-shaped bar 87 between the cam drive 86 and a bearing 88 mounted on a worm gear 90 is controlled in its leftward and rightward movement by a motor 91 that is connected via line 92 to the controller 32. Thus, upon the sensor 32 sensing marks 26, the longitudinal positioning of the cutter mechanism 80 can be precisely set, and the activation of the cam drive 86 to move the cutter 81 downwardly is controlled from the controller 32 via line 93, again, upon sensing by the sensor 30 of marks 26.

[0052] It should be apparent from the above, that only representative mechanisms are discussed for controlling the opening and closing of the decorative granule applicator systems 37 and 38, for controlling the leftward and rightward positioning of the decorative granule applicator systems 37 and 38, for controlling the manner in which the slot or other space cutting system 62 makes cutting contact with the shingle-forming layer 12, for controlling the leftward and rightward positioning of the slot or other space-cutting system 62, for controlling the manner in which the cutter 81 makes contact with the shingle-forming layer for cutting the same into discrete shingles, for controlling the manner in which the shingle cutting system 80 moves leftward or rightward, for proper cut-off placement as determined by the controller 32 and for controlling humidity in the manufacturing environment. As is specifically shown in FIG. 1, representative mechanisms and controlling apparatus are shown. However, it will be understood that in place of the particular systems shown, other systems either electrical and/or mechanical can be utilized. For example, other positioners than worm gears can be used, such as electrically operated solenoids, mechanically or pneumatically operated piston cylinders, or the like. Also, in lieu of the cams and cam

followers described above, solenoids, pistons or the like could be used in their places. Also, for purposes of cutting the slots or other spaces between adjacent tabs, and/or for use in cutting the shingle-forming layer into discrete shingles, apparatus such as that shown in U.S. Pat. No. 6,212,843 may be used, for cutting slots between tabs, for use as a shingle cut-off, and even for use in severing a pair of shingle-forming layer portions **12** and **20** (as is fragmentarily shown in phantom) in FIG. 1, along a common severance line. Thus, the apparatus as shown in FIG. 1 is merely one representative apparatus for accomplishing the shingle-completion steps in accordance with this invention. For purposes of transmission of signals, for example, for control of various mechanisms and apparatuses in the operation, wireless transmitted signals may provide an alternative to hardwired signal lines. Such signals may be electrical, electronic, optical, electro optic in nature, or of any other form.

[0053] There are several advantages to overall shingle design and aesthetics with regard to synchronization of color blend drops to tabs or fixed positions on a shingle and synchronization of shingle length. When cutouts are evenly spaced on a shingle and there is a fixed length it is critical that the synchronized length occur at the correct positioning such as in the middle of a cutout slot to give a balanced or center cut. This is important when applying multiple shingles so that a desired appearance of a uniform and seamless joint is present. Synchronization to the cutout slot position therefore is a critical advantage to a product having two or more layers. The advantage applies to a top layer with side edge cutouts and a bottom layer with a straight cut where the top layer is applied over the bottom layer and then cut to length and position by a synchronization.

[0054] Other applications to shingle product design and aesthetics could involve:

[0055] (a) petticoat (posterior layer extending below anterior layer) or top to bottom offset between adhered multiple layers including uniform and non-uniform bottom edge cut designs and varying heights of petticoat top to bottom offset and on-off petticoat height variations where a portion of the bottom edge is offset and another adjacent or non-adjacent portion is not offset from the bottom edge of two or more multiple layers;

[0056] (b) cutouts could be in non-uniform locations on the top or other layer locations and could be on one or more side edge locations;

[0057] (c) shingle lengths could also be of pre-designed lengths that are intended to be variable for a particular aesthetic appearance such as to simulate a wood shake appearance;

[0058] (d) cutout widths could vary in width across an individual shingle surface;

[0059] (e) cutout widths are thought to have the best aesthetics with uniform cutout widths less than one inch in width;

[0060] (f) cutouts could also vary in non-uniform height and could also vary in height when combined with varying widths;

[0061] (g) cutouts can also vary in non-uniformity of top to bottom dimension, such as not to be a continuous straight line on one or more sides. The same could hold true for left to right dimensions such as at the top or bottom of a cutout; and/or

[0062] (h) a slit or slice could also be considered as a cutout.

[0063] With reference to FIG. 1A, it will be seen that the shingle-forming layer **12'** may have granules applied via granule drop **37'** after bitumen is applied from lank **9'** while the layer **12'** passes between rollers **7'** and **8'**, and that after the granules are applied at **37'**, the shingle-forming layer passes around roller **38'**, and then the sensor **30'** senses a mark that has been applied to the shingle-forming layer **12'** after the marking tape **21'** is applied subsequent to the granule application at **37'**. The mark applied by the marking tape **21'** or via some other marking means is thus responsive to something that has already occurred and serves to trigger and/or control subsequent events.

[0064] With reference now to FIG. 2, it will be seen that a shingle **100** is fragmentally shown, as having a plurality of holes **101** applied in groupings **102**, as shown, by means of a mechanism **103** movable upwardly and downwardly in the direction of the double-headed arrow **104**, as shown, by a suitable motor, solenoid or the like (not shown), which in turn carries a base **105** (shown in phantom), which base, in turn, carries a plurality of piercing members **106**, for piercing the shingle-forming layer **107** to make a plurality of holes **101** that in a given collection **102** provide a mark, adapted for being sensed by a sensor **30** or the like, as described above, for accomplishing the shingle-completion steps described above. It will be understood that the holes **101** may be of any desired size or shape, may pass entirely through the shingle-forming layer **107**, or not, may take the form of notches or any other shapes, etc.

[0065] With reference now to FIG. 3, it will be seen that a shingle-forming layer **200** is shown, in which barcode(s) **201**, identical or different from each, other, as may be desired, are applied to the upper surface **202** of the shingle-forming layer **200**, by means of a barcode printer or the like **203** applying the same onto a tape **204** applied to the upper surface of the shingle-forming layer **200**. Alternatively, the barcode(s) may be applied directly to the upper surface of the shingle-forming layer, as may be desired. In a similar manner as described above, the barcode(s) may be read by a sensor such as that **30** or the like, for controlling the shingle-completion steps. Such barcodes can be at least one-dimensional in nature, or two-dimensional or more complex images, depending upon the complexity of the information necessary to control multiple actions and operations in the manufacture of the finished shingles.

[0066] With reference to FIG. 4 a shingle-forming layer **300** is shown, comprising a multi-layer formation, including an upper layer **301** and a lower layer **302**, adhesively secured together to form a multi-layer shingle, after the shingle-forming layer **300** is severed into discrete shingles.

[0067] As with the embodiment shown in FIG. 1, the upper surface of the shingle-forming layer **300** is provided with a tape **303** having a plurality of marks **304** thereon for detection by a sensor such as that **30** or its functional equivalent, as described above, for controlling shingle-completion steps.

[0068] With reference now to FIG. 5, as distinguished from the even spacing-apart of the marks **304** as shown for the embodiment of FIG. 4, the marks **404** on the shingle-forming layer **400** of the embodiment of FIG. 5, are unevenly spaced apart to provide a predetermined non-repeatability of features of subsequent shingle-completion steps.

[0069] In FIG. 6 a shingle **500** is shown, having a tape **501** on the upper surface, which tape **501** has a plurality of marks **502** thereon, with the marks **502** being spaced apart to define placement precisely aligned therewith for slots **503**. The tape

501 is applied in a manner similar to that described above for the tape discussed with respect to FIG. 1, and the slots **503** are likewise controlled in their placement by a controller such as that **32** of FIG. 1 that, in turn, is actuated by means of a sensor such as that **30** of FIG. 1 sensing the marks **502**.

[0070] In FIG. 7 a shingle **600** is presented, having a tape **601** applied to an upper surface thereof, with irregularly spaced marks **602**, that dictate via a sensor such as that **30** and controller such as that **32**, the placement of slots **603** between adjacent tabs **604** of the shingle **600**, to correspond to the placement of marks **602**, in the longitudinal direction.

[0071] With reference now to FIG. 8, a shingle **700** is shown, having four tabs, each with its own decorative covering of granules thereon, each having its own aesthetic appearance.

[0072] The four different granule drops that produce the differently decorated tabs **701**, **702**, **703** and **704** are controlled in the manner described above with respect to FIG. 1. As was discussed above with respect to FIG. 1, any desired number of granule drop systems such as those **37** and **38** can be used. In the case of the shingle of FIG. 8, preferably four such systems are used to produce the different aesthetic presentations shown for the tab portions **701-704** of the shingle **700**. Likewise, the precise placement of slots such as those **705** between adjacent tabs may be controlled in the manner described above with respect to FIG. 1. It will be understood that the shingle **700** of FIG. 8 could be an anterior layer of a multilayer shingle, where a posterior layer (not shown) may have portions visible between and/or extending below the lower edges of the tab portions **701-704**.

[0073] It will be understood that where different decorative granule applications are applied to shingle tab areas, such as those shown in FIG. 8, those shown in FIG. 1, or those shown in the other figures of this application, any individual granule drop from, its granule applicator may be comprised entirely of granules of a given color or size, or may be comprised of predetermined blends of granules of different colors and/or sizes, but that the different presentations for the different tabs, such as shown in FIG. 5 depict different visual appearances for the tabs.

[0074] With reference to FIG. 9, a shingle **800** is illustrated having tabs **801**, **802**, **803** and **804**, of different visual decorations, as described above with respect to FIG. 8, but in the case of the tabs of FIG. 9, shading areas **805** are shown on the left side of each tab, representing another visual decoration that may be applied by sensing marks and controlling the application of granules, for example, of darker selection, from a granule applicator, all as sensed and controlled in a manner such as is set forth above with respect to the description of FIG. 1.

[0075] With reference to FIG. 10, a multi-layer shingle **900** is shown, having an upper layer **901** and a lower layer **902**. The upper layer has tabs **903** precisely spaced apart in a manner as controlled by a system such as that described above with respect to FIG. 1. However, in the illustration of FIG. 10, a shim provides the layer **902**, either of full height or approximately half height, laminated behind the layer **901**, and wherein decorative frontal or anterior surface portions **904** for the posterior layer **902** are visible between adjacent tabs **903** to provide a dragon's tooth effect. In the embodiment shown in FIG. 10, the visible portions **904** of the anterior surface of the posterior layer **902** are of the same decorative or aesthetic effect, but it will be understood that such could be of different aesthetic effects. It will also be apparent that the control of

placement of the decorative granules on the posterior layer **902** can be as controlled in the manner described above with respect to the various mechanisms of FIG. 1.

[0076] With reference now to FIG. 11, a shingle **920** is illustrated as having an upper or anterior shingle layer **921** and a lower or posterior shingle layer **922** adhesively secured thereto to make a laminated two-piece shingle. The shingle **920** is also of the dragon's tooth type, wherein spaced apart tabs **923** have angled right and left edges and have spaces therebetween as determined by the slot or space making technique as described above with respect to FIG. 1 are made, and with the spaces between the tabs **923** showing anterior surface portions of posterior layer **922** therethrough, as shim zones **924**. It will be noted that each of the shim zones **924** and each of the tabs **923** have different decorative configurations, either by having different colored and/or sized granules thereon, or by having different mixes of various colored granules and/or granule sizes thereon, but wherein each tab and each shim zone presents a different aesthetic variation. It will be understood that the various decorative tab areas and shim areas as shown in FIG. 11 may have their placements precisely controlled in accordance with the method described above with respect to FIG. 1.

[0077] With respect to FIG. 12, a shingle **940** is illustrated, of the single layer type, in which the spaces **941** between adjacent tabs **942** are more widely spaced apart than the slots, for example for the shingles illustrated in any of FIGS. 6-9, to yield a dragon's tooth effect, and wherein the anterior surfaces of the tabs **942** each have some decorative variation from the other tabs, which variations can be in different colors or sizes of granules, different blends of colors or sizes of granules, or the like, all as may be desired.

[0078] In FIG. 13, the anterior layer **950** and posterior layer **951** for the shingle **952** are shown, with the posterior layer portions **953** and **954** providing a petticoat effect **953** beneath anterior tabs **954** and visible posterior portions **955** between anterior tabs **954**, respectively. FIG. 13A shows a full height backing or posterior layer **951** behind anterior layer **952** and FIG. 13B shows a partial height backing or posterior layer **956** behind anterior layer **952**, each with a petticoat portion **953** and visible portions **955** as discussed above. The tabs **954** could be different in color or shading, in whole or in part, as may be desired.

[0079] It will be understood from the above that many variations can be made in the shingles that are made in accordance with the process of this invention, and that variations can be made in the processes as well. For example, the marks that are made on a tape may be in the shape of a square or rectangle, and that the tape may be a film or other thin substrate attached or adhered to the shingle-forming layer. The marks can be printed on either or both sides, for example of a clear substrate, and the substrate may be comprised of paper, parchment, or films commonly used in the roofing industry and applied to roofing shingles or rolls. Such tapes can be, but are not limited to, those of polyester, nylon, polypropylene or the like, and may be metalized or comprise combinations of layered film types to add integrity or heat resistance. To add resistance where tension, can be a concern, a reinforced film substrate with reinforcement strands in the longitudinal, or machine direction may, if desired, be included as components of the tape.

[0080] The marks can be magnetic in nature, if desired, can have color contrast, can be radioactive, or can be otherwise

measurable or distinctive, to be detected by a sensor having a means for detection of such marks.

[0081] The shingle-forming layer can be, if desired, of a contrasting color relative to the marks, such as dark in the case of a light mark, or light in the case of a dark mark, or can be metalized or clear in nature, such that dark asphalt showing through a clear tape can give contrast to a lighter colored mark. It will also be clear that the marks, whether applied by means of a tape or the like, or not, can be applied to either the top or bottom side of a shingle-forming layer, as may be desired, and that the marks can be of various shapes, widths and lengths as may be required by a desired sensor, if the mark is applied to a tape or the like, such tape could also function as a release film, in that release films are commonly used in the roofing industry to be applied against an adhesive strip, in bundling of shingles, to keep adjacent bundled shingles from sticking together, but which will facilitate their separation when installed on a roof. The tape could also be light colored in nature when applied over a darker shingle-forming layer, and in instances in which the mark is in the form of perforations in such a tape, the darker color showing through the tape could be the mark that is detectable by a sensor. It will also be apparent that in accordance with this invention, shingles having no tabs may be enhanced by having in their tab regions which comprise the lower portion of the shingle as it is installed on a roof, different decorative presentations adjacent each other, precisely applied in accordance with the features of the present invention, yet wherein no slots or spaces are formed in the tab regions and consequently no distinct tabs as such are presented.

[0082] It will thus be apparent from the foregoing that various modifications may be made in the details of shingle construction, as well as in the method of making such shingles, all within the spirit and scope of the invention as defined in the appended claims.

- 1. (canceled)
- 2. (canceled)
- 3. (canceled)
- 4. (canceled)
- 5. (canceled)
- 6. (canceled)
- 7. (canceled)
- 8. (canceled)
- 9. (canceled)
- 10. (canceled)
- 11. (canceled)
- 12. (canceled)
- 13. (canceled)
- 14. (canceled)
- 15. (canceled)
- 16. (canceled)
- 17. (canceled)
- 18. (canceled)
- 19. (canceled)
- 20. (canceled)

21. A manufactured shingle in which the shingle has a butt region and a tab region with the tab region having decorative granules applied thereto, the shingle comprising:

- (a) a shingle-forming layer comprised of shingle reinforcement material impregnated with a bitumen material, the layer having a butt region and a tab region;
- (b) an optional layer of headlap granules on an upper surface of at least the butt region of the shingle-forming layer;
- (c) a plurality of marks carried by the shingle-forming layer, with the marks being provided at pre-determined longitudinally spaced-apart distances from each other and comprising sensing means for aiding in controlling the timing and placement of features of the shingle;
- (d) said marks comprising any of:
 - (i) a marking tape with a plurality of marks thereon;
 - (ii) a plurality of groups of holes;
 - (iii) barcode(s);
 - (iv) placement indicated for placement of decorative granules;
 - (v) placement indicators for placement of different colored granules; and
 - (vi) placement indicators for placement of different sized granules.

22. A manufactured building product in which the building product has a butt region and a tab region with the tab region having decorative granules applied thereto, the shingle comprising:

- (a) a building product-forming layer comprised of building product reinforcement material impregnated with a bitumen material, the layer having a butt region and a tab region;
- (b) an optional layer of headlap granules on an upper surface of at least the butt region of the building product-forming layer;
- (c) a plurality of marks carried by the building product-forming layer, with the marks being provided at pre-determined longitudinally spaced-apart distances from each other and comprising sensing means for aiding in controlling the timing and placement of features of the building product;
- (d) said marks comprising any of:
 - (i) a marking tape with a plurality of marks thereon;
 - (ii) a plurality of groups of holes;
 - (iii) barcode(s);
 - (iv) placement indicated for placement of decorative granules;
 - (v) placement indicators for placement of different colored granules; and
 - (vi) placement indicators for placement of different sized granules.

23. (canceled)

24. (canceled)

25. A shingle according to claim 21, wherein the marks comprise high visual contrast areas relative to the shingle-forming layer to which they are applied.

26. (canceled)

27. A shingle according to claim 21, wherein the marks comprise coded holes applied to the shingle-forming layer.

28. (canceled)

29. (canceled)

30. (canceled)

* * * * *