



US00D822748S

(12) **United States Design Patent**
Van Deusen et al.

(10) **Patent No.:** **US D822,748 S**

(45) **Date of Patent:** **** Jul. 10, 2018**

(54) **VEHICLE-MOUNTED CAMERA MODULE**

(71) Applicant: **Lytx, Inc.**, San Diego, CA (US)

(72) Inventors: **Marie Van Deusen**, Poway, CA (US);
Ken Sung, San Diego, CA (US); **Scott Stewart**, Boise, ID (US)

(73) Assignee: **Lytx, Inc.**, San Diego, CA (US)

(**) Term: **15 Years**

(21) Appl. No.: **29/575,261**

(22) Filed: **Aug. 23, 2016**

(51) **LOC (11) Cl.** **16-01**

(52) **U.S. Cl.**

USPC **D16/218; D16/208**

(58) **Field of Classification Search**

USPC D16/200–204, 208, 218, 219;
D12/187–189, 400; 340/932.2, 933, 937;
348/143, 148, 151, 360, 373–376;
396/419, 427–429, 433, 529, 535,
396/537–541

CPC G03B 15/03; G03B 17/02; G03B 17/04;
G03B 17/48; G03B 17/56; G03B 19/04;
G08G 1/0175; H04N 5/2251; H04N
5/2252; H04N 5/2253; H04N 5/2254

See application file for complete search history.

(56) **References Cited**

U.S. PATENT DOCUMENTS

D484,160 S *	12/2003	Kangasmaa	D16/202
D518,842 S *	4/2006	Hilborn	D16/200
D542,820 S *	5/2007	Depay	D16/202
D591,321 S *	4/2009	Sheppard	D16/202
D610,178 S *	2/2010	Adolfsson	D16/200
D617,821 S *	6/2010	Kaplan	D16/202
D624,106 S *	9/2010	Cho	D16/203

D636,424 S *	4/2011	Lin	D16/202
D736,845 S *	8/2015	Yilin	D16/203
D737,878 S *	9/2015	Zhang	D16/218
D755,875 S *	5/2016	Geng	H04N 5/2251
				D16/203
2012/0327234 A1 *	12/2012	Fish, Jr.	H04N 7/185
				348/148
2013/0107110 A1 *	5/2013	Park	H04N 5/2252
				348/373

* cited by examiner

Primary Examiner — Philip S Hyder

Assistant Examiner — Ramzi Almatrahi

(74) *Attorney, Agent, or Firm* — Van Pelt, Yi & James
LLP

(57) **CLAIM**

We claim the ornamental design for a vehicle-mounted camera module, as shown and described.

DESCRIPTION

FIG. 1 is a front and left side perspective view of a vehicle-mounted camera module showing our new design. FIG. 2 is a top, front and left side perspective view thereof. FIG. 3 is a bottom rear and left side perspective view thereof.

FIG. 4 is a top, rear and right side perspective view thereof. FIG. 5 is a top, rear and left side perspective view thereof. FIG. 6 is a front view thereof.

FIG. 7 is a rear view thereof.

FIG. 8 is a top view thereof.

FIG. 9 is a bottom view thereof.

FIG. 10 is a left side view thereof; and,

FIG. 11 is a right side view thereof.

The broken lines depict portions of the vehicle-mounted camera module in which the design is embodied that form no part of the claimed design.

1 Claim, 6 Drawing Sheets

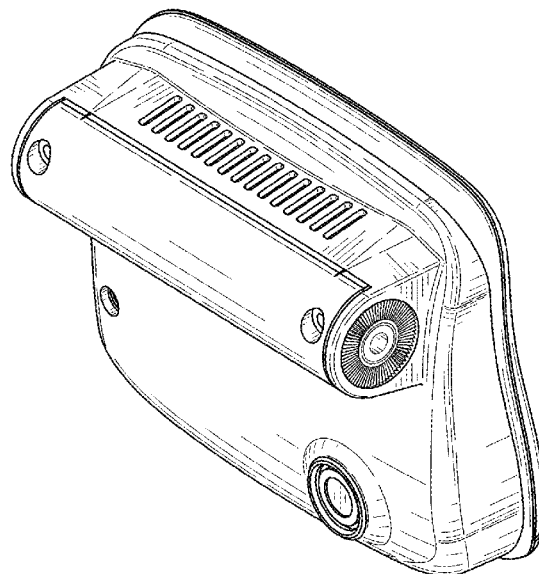
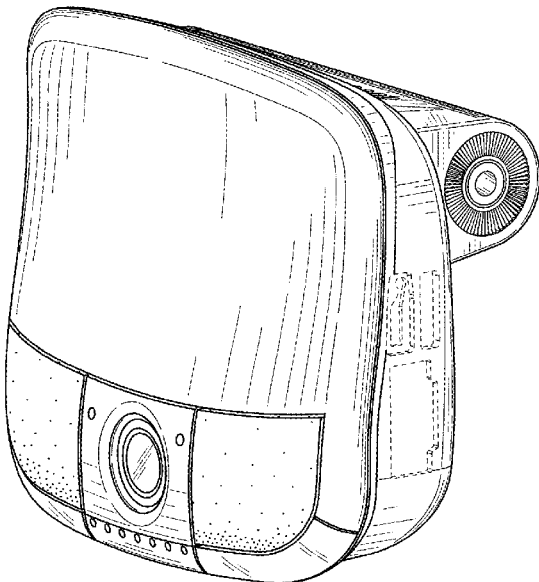

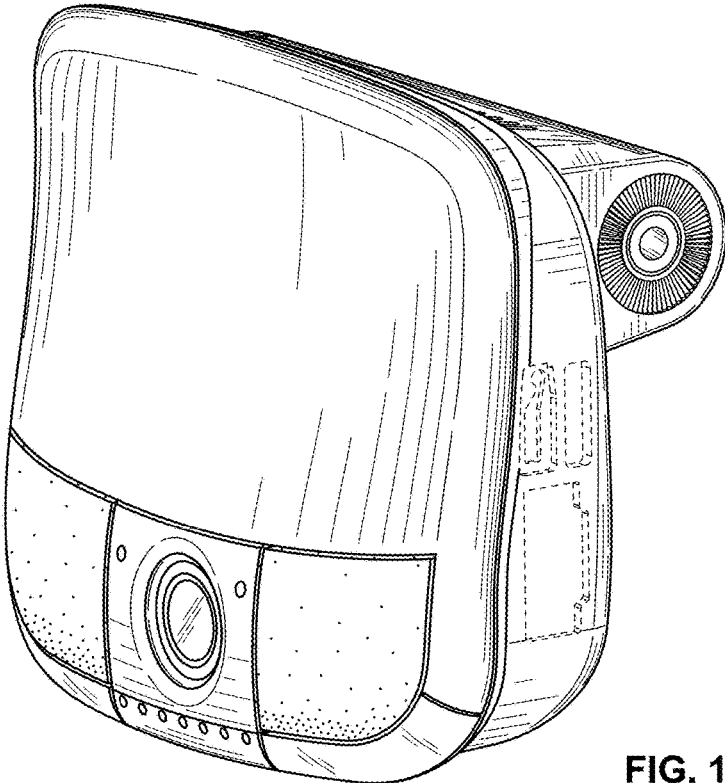

FIG. 1

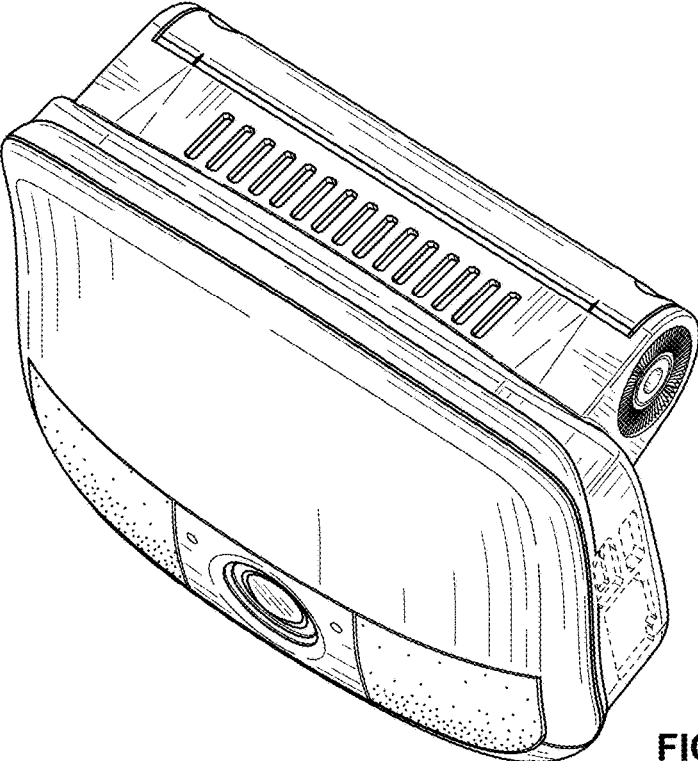

FIG. 2

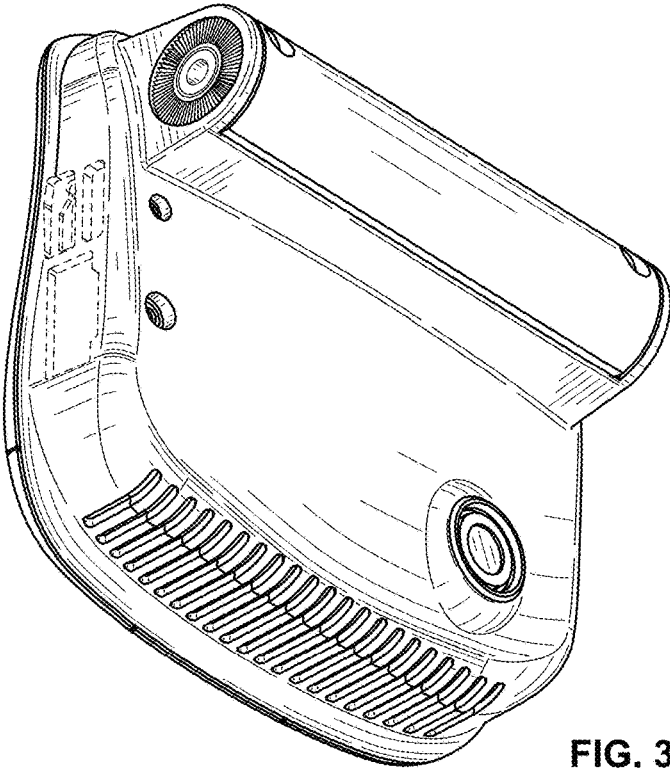

FIG. 3

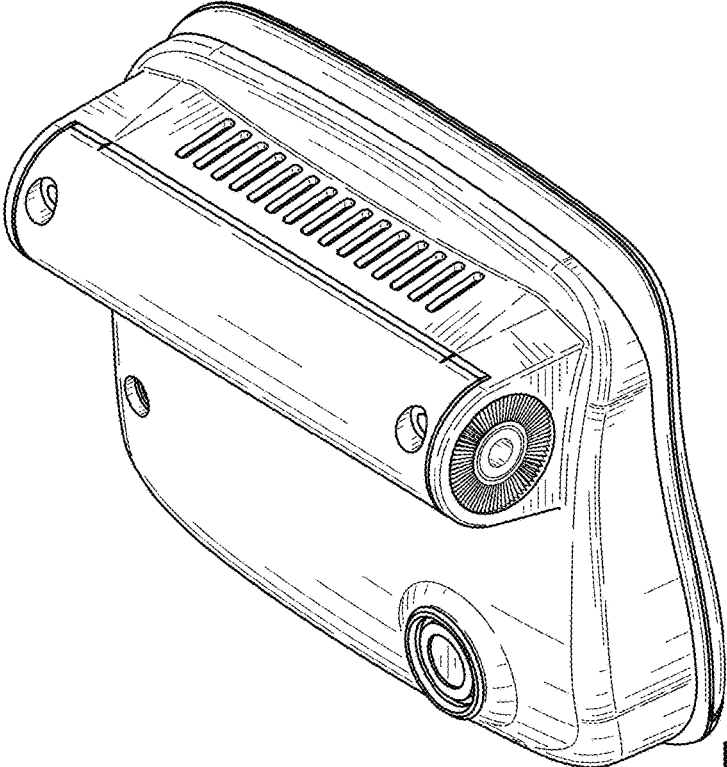

FIG. 4

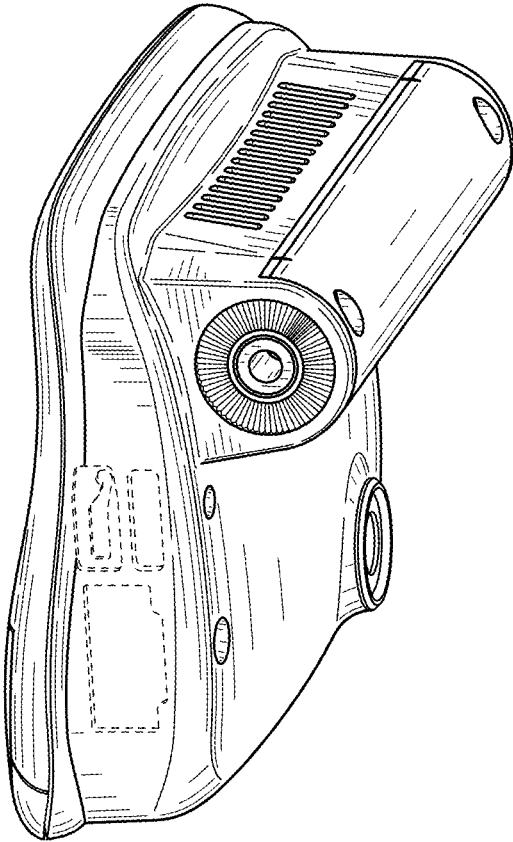

FIG. 5

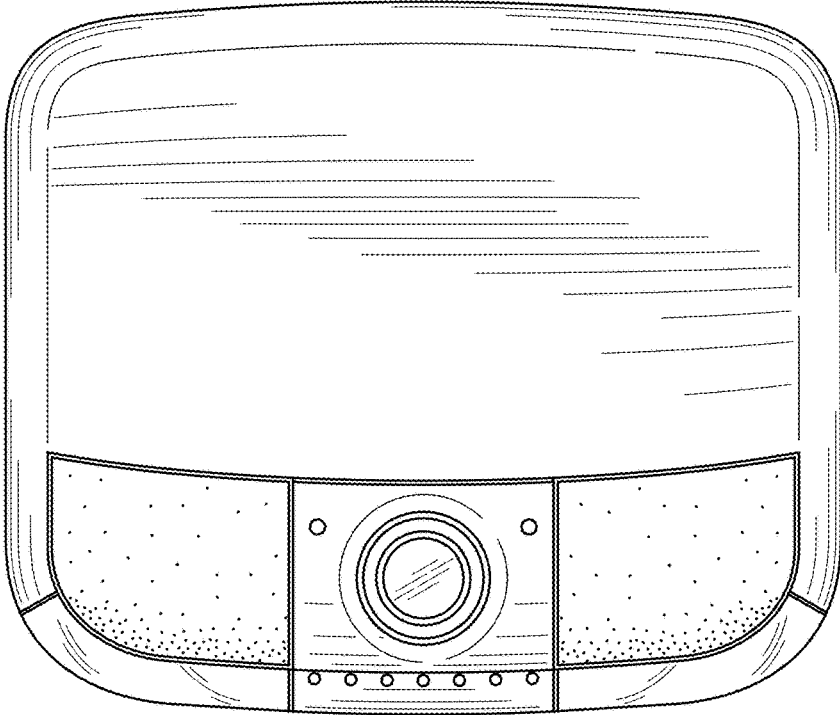

FIG. 6

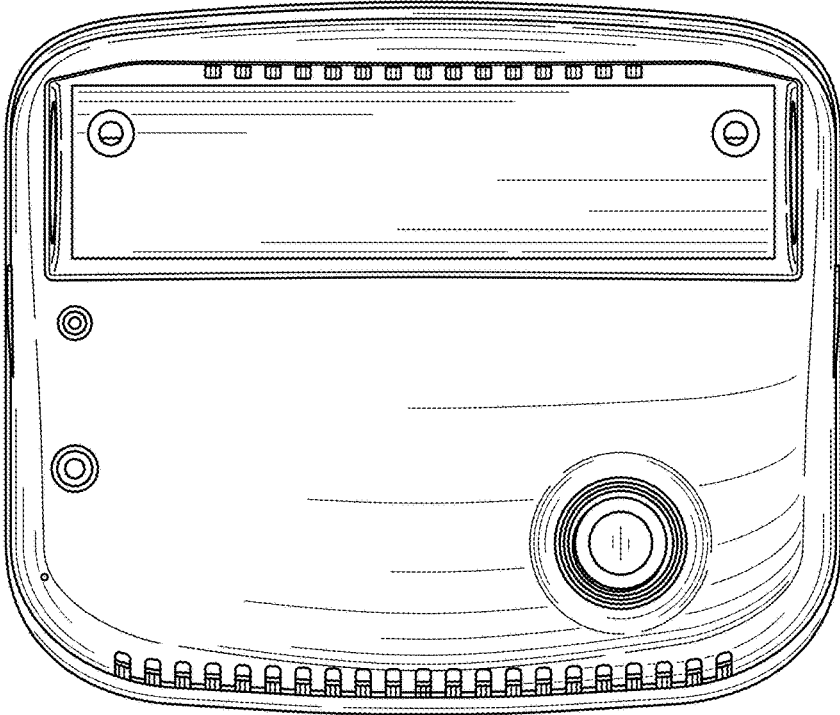

FIG. 7

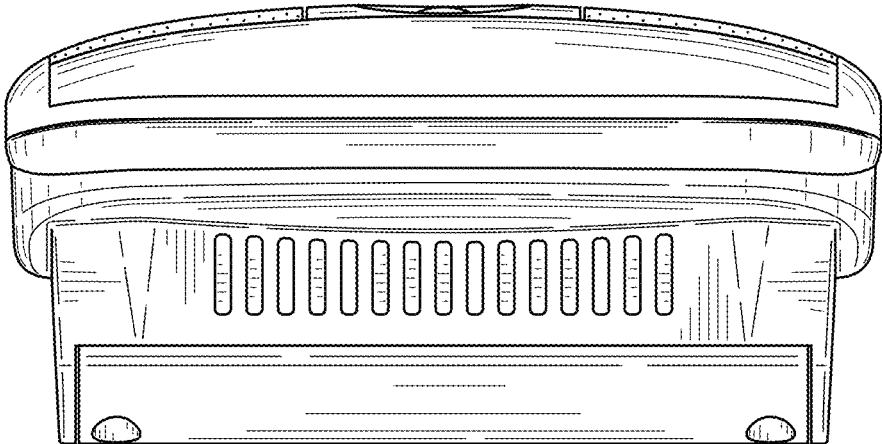

FIG. 8

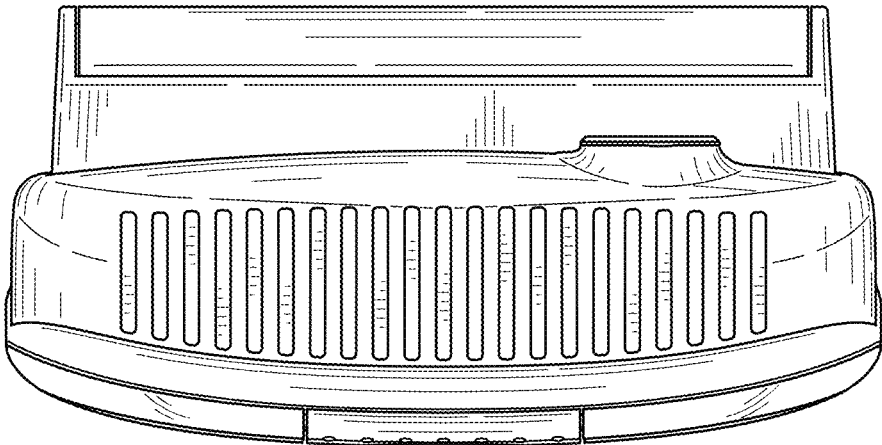

FIG. 9

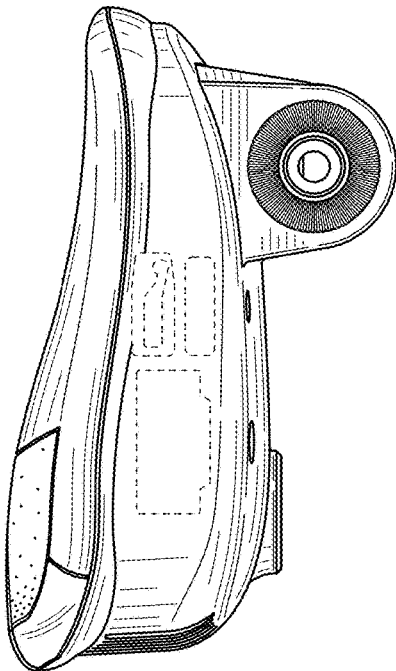

FIG. 10

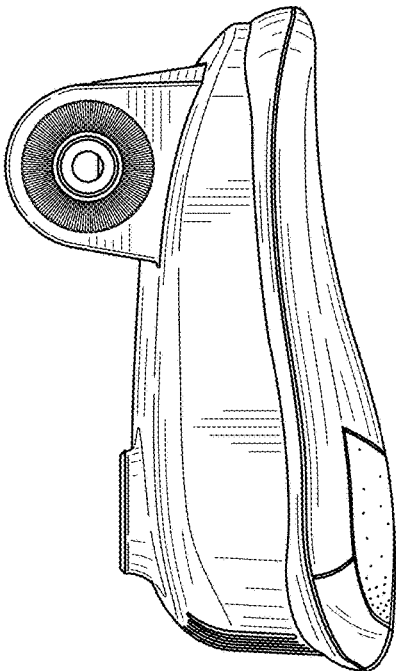

FIG. 11