

May 17, 1966

F. M. LUND

3,251,923

KEYBOARD OPERATED ELECTRICAL SWITCHES

Filed May 29, 1962

2 Sheets-Sheet 1

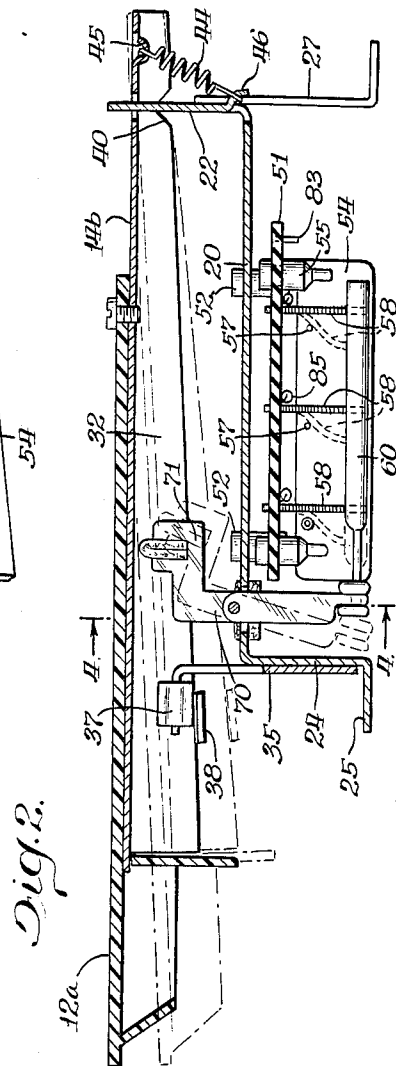
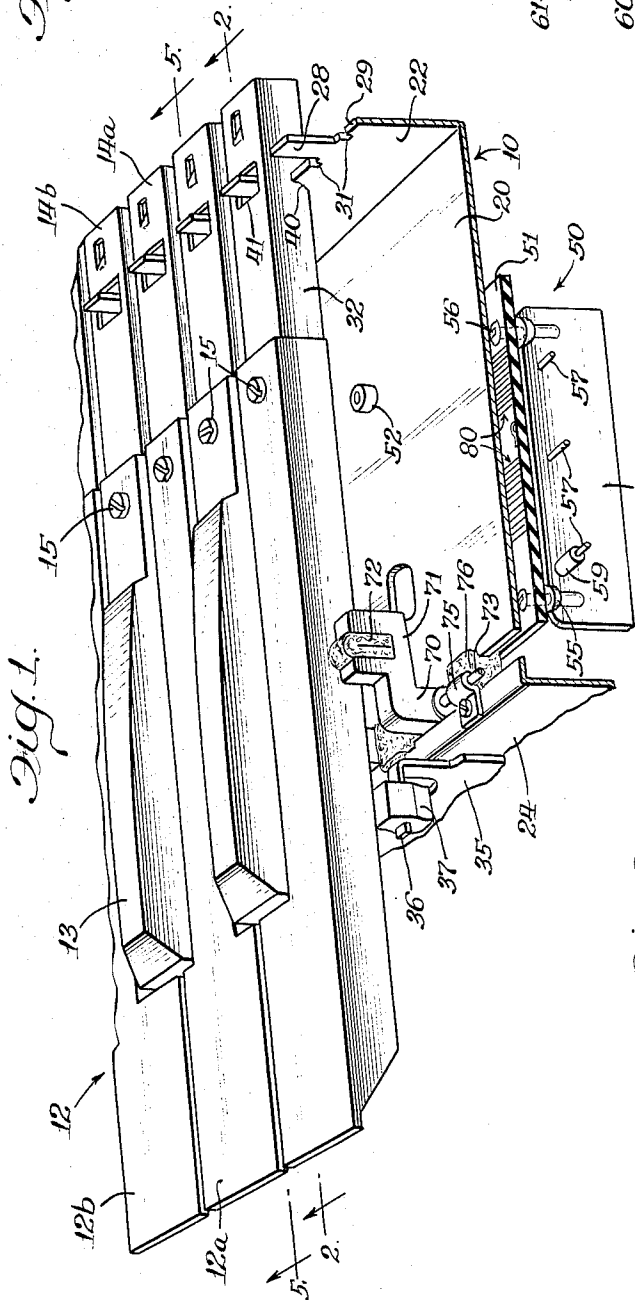
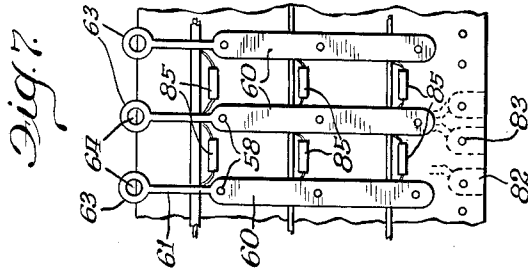
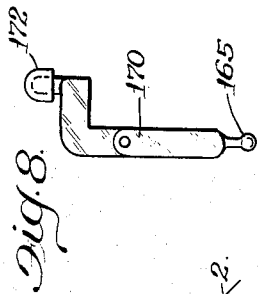

INVENTOR.  
*Frank M. Lund*  
 BY *Muell. & Aichele*

*Atlys.*

May 17, 1966

F. M. LUND

3,251,923

KEYBOARD OPERATED ELECTRICAL SWITCHES

Filed May 29, 1962

2 Sheets-Sheet 2

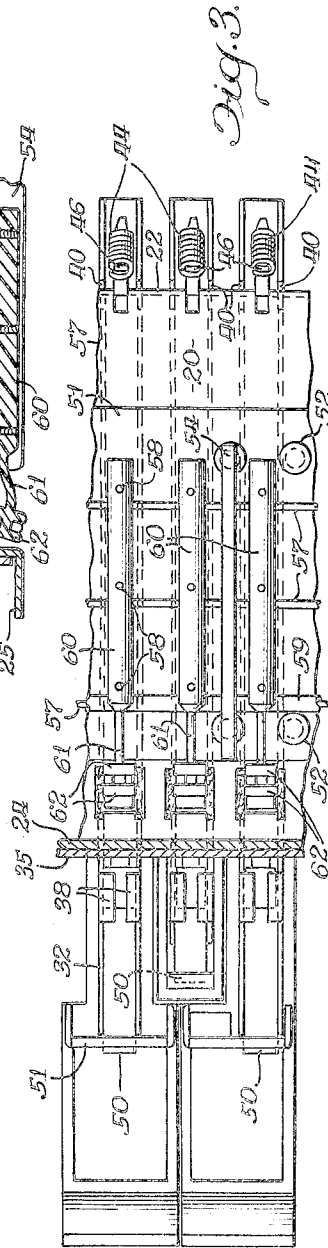
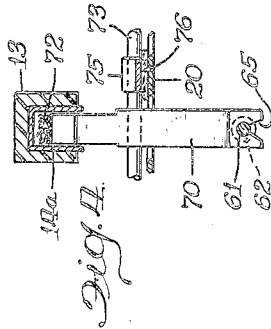
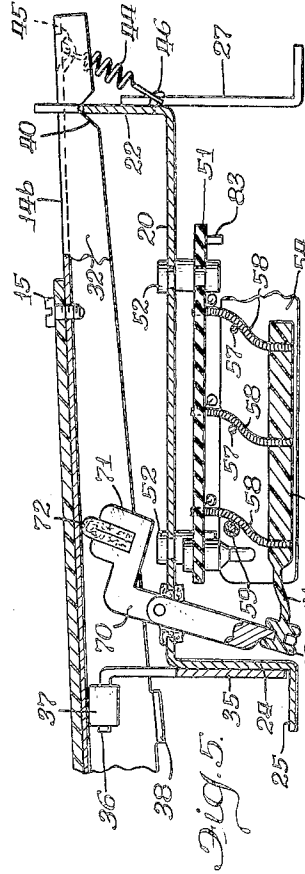
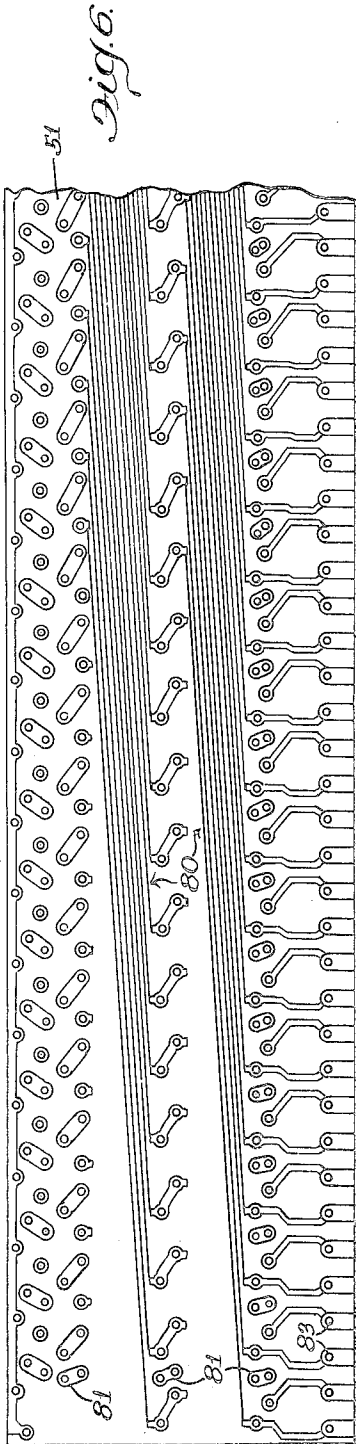

INVENTOR.  
*Frank M. Lund*  
 BY *Mueller & Aichele*

*Atlys.*

1

3,251,923

## KEYBOARD OPERATED ELECTRICAL SWITCHES

Frank M. Lund, Northbrook, Ill., assignor to Pratt, Read & Co., Incorporated, Ivoryton, Conn., a corporation of Connecticut

Filed May 29, 1962, Ser. No. 198,670  
8 Claims. (Cl. 84-1.01)

This invention relates to switching circuits and particularly to key switches for selectively coupling individual tone generators to electroacoustical transducers wherein selected tone signals are converted to musical expressions.

In electronic musical instruments such as organs, pianos, and accordions, it is conventional to provide means which activates a switch upon depression of a selected key on the keyboard to complete an electrical circuit between associated tone generators and mixing busses so that given waveforms of a selected frequency can be coupled to electroacoustical transducers to produce a desired musical effect. It is important that the keys and their associated switches operate with a minimum of manual pressure to provide a firm reliable electrical contact without generating objectionable mechanical and electrical noise. Because of the large number of circuits involved, it is also desirable that the circuit making elements coacting with individual keys to provide the switching be durable to insure operating life yet be simple in construction to form a compact unit which is economical to assemble and is readily accessible for maintenance.

It is therefore an object of the present invention to provide a key switch assembly for use with electronic musical instruments that is essentially free from noise during operation.

A further object is to provide a key switching arrangement for use with electronic musical instruments which makes positive and reliable electrical contact with associated mixing busses, and which incorporates a construction that insures long operating life.

Another object is to provide a key switch assembly for coaction with a musical keyboard which is operable by a minimum of manual pressure applied to individual playing keys.

Still another object is to provide an electrical key switch which employs a simple and compact circuit interconnection panel that can be economically fabricated and readily assembled with the coacting keyboard.

A feature of the present invention is the provision of a keyboard having pivotally mounted key assemblies and coacting lever arms adapted to move in an arcuate path upon activation of individual key assemblies. A resilient insulating member forms a flexible tie-bar connected between one end of each lever arm and flexible coil springs to impart translational movement to the free ends thereof to make electrical contact with stationary signal mixing busses, thereby completing an electrical circuit between individual tone generators associated with selected key assemblies and the electroacoustical transducers of the system.

A further feature of the invention is the provision of an organ key switch arrangement including a plurality of coil springs having a fixed end supported by a plated circuit panel and a free end coupled by a flexible insulating member to a key activated lever arm. The flexible member imparts translational movement to the free ends of the coil springs upon arcuate movement of the lever arm by depression of selected keys to make electrical contact with mixing busses, and a plated or etched circuit wiring pattern interconnects the coil springs and isolation resistors disposed on the circuit panel to complete an electrical cir-

2

cuit between selected tone generators and the audio amplifiers of the system.

Another feature is the provision, in a key switch arrangement of the type described above, of a coating of resilient resistive material on the mixing busses to provide noise deadening during the switching operation and to provide a predetermined resistance value in the circuit.

A still further feature is the provision of a tie-rod molded from resilient insulating material to couple the key activated lever arm to the free ends of selected coil springs in the above-described switching arrangement to provide positive, noiseless switch activation with a minimum of keyboard pressure.

Other objects, advantages and features of the invention will become apparent upon making reference to the following specification, claims and drawings, in which:

FIG. 1 is a fragmentary perspective view of an organ keyboard chassis assembly incorporating the key switching arrangement of the present invention;

FIG. 2 is a vertical sectional view of the keyboard chassis assembly of FIG. 1, taken substantially along line 2-2;

FIG. 3 is a bottom plan view of the chassis assembly of FIG. 1;

FIG. 4 is a transverse section taken substantially along line 4-4 of FIG. 2;

FIG. 5 is a vertical sectional view of the keyboard chassis assembly of FIG. 1, illustrating a key in a depressed position, taken substantially along line 5-5;

FIG. 6 is a plane view of the plated circuit panel of the invention, illustrating a typical circuit configuration;

FIG. 7 is a fragmentary perspective of circuit panel showing an alternate configuration of the means coupling the coil springs to the lever arms actuated by the key assemblies; and

FIG. 8 is a view of an alternate type of lever arm for use in the assembly of FIG. 1.

In practicing the present invention there is provided a generally flat chassis having an upstanding fulcrum-forming wall on the rear marginal edge thereof and a plurality of upstanding fingers on the front marginal edge thereof. A plurality of elongated key assemblies are transversely disposed between the two marginal edges, with the fulcrum-forming wall providing pivotal points for the key assemblies and the upstanding fingers cooperating with the key assemblies to provide up and down stops. Each key assembly is maintained in a normally up position by a biasing spring and may be depressed to the down position by application of sufficient manual pressure to overcome the bias thereby provided. Lever means associated with each key assembly include arms extending above and below the chassis through openings in the flat portion of the chassis, and are mounted to pivot about a horizontally disposed axis located near the front marginal edge of the chassis. Extensions of the lever arms above the chassis include off-center portions which coact with individual key assemblies to provide rotation of the levers and thus arcuate movement of the arms extending below the chassis within the limits provided by the up and down stops as individual key assemblies are depressed.

A generally elongated insulating panel is provided below a flat portion of the chassis, coextensive with the key assemblies. The insulating panel contains plated or tilted circuit wiring patterns and associated circuit components for interconnection of individual tone generators with the audio amplifiers and the electroacoustical transducers of the associated audio system. A plurality of signal mixing busses, which further function as the fixed contacts for the switching arrangement, are supported from and extend the length of the insulating panel. A plurality of resilient,

closely wound electrically conductive coil springs are pendent from the insulating panel in close proximity to the mixing busses. The free end of selected ones of the coil springs are mechanically joined by an insulating member, which member further includes a flexible portion coupled to the lower extending arms of the lever means. Thus, when individual key assemblies are manually depressed to cause rotation of a coacting lever arm, the flexible coupling portion of the insulating member imparts a translational movement to the free ends of the coil springs to thereby complete an electrical circuit between associated coil springs and the mixing busses. Release of manual pressure from the key assembly causes it to be biased to its normal up position and the resilient coil springs return to their pendent positions to open the electrical circuit.

In a typical electronic organ system isolation resistors are series wired between selected coil springs and individual tone generators. Contact with the mixing busses completes the circuit between the tone generators and the audio amplifiers and acoustical transducers of the system. A predetermined plate or etched circuit wiring pattern disposed on the insulating panel interconnects isolation resistors, also located on the panel, to selected coil springs so that depression of individual keys provides the necessary signal mixing to produce a desired musical effect. The plated or etched circuit wiring pattern and the interconnecting isolation resistors may be disposed in a manner to provide octave-to-octave coupling with the mixing busses, depending on the complexity of the individual musical instrument with which the key switch arrangement is used. To further enhance noise free operation of the switching arrangement a pliable resistive material may be applied to the mixing busses. This material may be selected to provide a fixed or variable value of resistance between the coil springs and the busses, or may be of substantially zero resistance.

Referring now to FIGS. 1 and 2 of the drawings, the keyboard assembly incorporating the key switch arrangement of the present invention includes an elongated chassis member 10 having a substantially flat horizontal portion 20. A plurality of key assemblies 12 are supported in longitudinally spaced relation upon the chassis member 10 to form a conventional organ or accordion keyboard. Each key assembly comprises a left or right hand white key piece 12a or 12b or a black key piece 13, and an elongated channel-shaped arm 14a or 14b, the front portion of which is overlaid by the key piece involved. Individual key pieces are secured to channel-shaped arms 14a or 14b by a plurality of screws 15. The left hand white key piece 12a and the right hand white key piece 12b is shaped to extend part way around the front portion of black key piece 13 in the usual manner.

Chassis member 10 is made of a single sheet metal stamping having a main generally horizontal rectangular panel section 20 an upwardly projecting fulcrum-forming wall 22 extending for substantially the full length of the rear longitudinal margin, and downwardly projecting flange portion 24 extending substantially the full length of the front longitudinal margin. Downwardly projecting portion 24 is provided with bracketed feet 25 for front support and bracketed legs 27 provide rear support for the chassis assembly. A series of upwardly projecting longitudinally spaced fingers 28 extend upwardly from the horizontal upper marginal edge 29 of fulcrum forming wall 22. A plurality of slots 31 are provided in upper marginal edge 29 of fulcrum forming wall 22. These slots are spaced apart at a distance slightly greater than the longitudinal width of upwardly projecting fingers 28 and coincide with downwardly extending flanges 32 on arms 14a and 14b.

A front member 35, containing a series of longitudinally spaced fingers 36, is secured to the front longitudinal margin of rectangular panel section 20. Fingers 36 have a portion struck parallel to horizontal section 20 and are

in transverse alignment with upwardly projecting fingers 28. A body of resilient flexible material 37, such as neoprene rubber or a suitable plastic material, generally rectangular in cross-section and having a small aperture therein is secured to fingers 36 in the manner shown. Referring more specifically to FIGS. 3 and 5, side flanges 32 of elongated arms 14a and 14b are provided with inwardly projecting lugs 38 on the bottom thereof, located directly above the horizontal portion of fingers 36. Lugs 38 form horizontal abutment shoulders at the bottom of elongated channels 14a and 14b to abut against the bottom portion of resilient stop member 37 to thereby limit the upward movement of individual key assemblies, as is most clearly shown in FIG. 2 wherein the key assembly including key piece 12a and arm 14b is shown in its upmost position. Sufficient clearance is provided between the upper surface of flexible stop member 37 and the top of elongated channels 14a and 14b to permit the necessary downward movement of the key unit involved. Thus, by abutment against lugs 38 when the key assembly is in its upmost position and against the top of elongated channel-shaped arms 14a and 14b when the key assembly is in its downmost position, flexible stop member 37 functions as both an upstop and a downstop for the key assembly.

Side flanges 32 of elongated channel-shaped arms 14a and 14b are further provided with generally V-shaped notches 40. These notches are engaged with slots 31 in the upper marginal edge 29 of fulcrum-forming wall 22 to provide the fulcrum point for the key assemblies. Fingers 28 extend through a plurality of generally rectangular openings 41 in the upper surface of arms 14a and 14b. Openings 41 have sufficient width to just engage the longitudinal edges of fingers 28. This engagement, in conjunction with the engagement of notches 40 with slots 31 on fulcrum forming wall 22, prevent relative lateral movement between channel-shaped arms 14a and 14b and the chassis member. When assembled fingers 28 pass through openings 41 and the apex of V-shaped notches 40 engage the bottom slots 31 thereby forming the fulcrum points which pivotally support individual key assemblies. Sufficient clearance exists between the front and rear of fingers 28 and the front and rear of openings 41 so that the fingers do not touch the front and rear portions of openings 41 for all positions of the key assembly. On the other hand, there is little or no clearance between the fingers 28 and the sides of the walls of openings 41, thus restraining lateral movement of the key assemblies. Individual key assemblies are spring biased by tension spring members 44 extending between spring anchoring lugs 45 and 46 respectively, struck from the channel-shaped arms and from the chassis member. The front ends of the key assemblies are thereby biased upwardly, with the upward movement of each key assembly limited by stop member 37 in abutment with lugs 38.

As has been previously mentioned, individual key pieces are secured to the channel-shaped arms by screws 15. Each of channel shaped arms 14a and 14b have forward extending tongue portions 50 on the upper surface, as best seen in FIG. 3. Each key piece is of a generally hollow configuration molded from thermoplastic material such as, for example, acrylic or butyrate resin, and adapted for a close fit with each of their respective channel-shaped arms. Tongues 50 on the forward end of the channel-shaped arms associated with the black key pieces engage a slot in the forward end thereof to anchor the front of the black key pieces. To provide additional rigidity for the relatively wider forward end of the white key pieces, a transverse web 51 is provided. A slot in this web receives tongues 50 for the channel-shaped arms associated with the white key pieces to thereby anchor the forward end of the white key pieces.

The electrical circuit assembly shown generally at FIG. 6 includes a plurality of circuit making contacts adapted to be operated in conjunction with manual operation of

individual key assemblies, is disposed below longitudinally extending horizontal channel portion 20. An insulating board 51 extends the entire length of the keyboard chassis and is supported immediately below chassis portion 20 by a plurality of rubber or neoprene grommets 52. As shown in detail in FIG. 6, insulating board 51 has disposed on the top surface thereof a plated or etched circuit pattern of a predetermined configuration. A plurality of flat insulating members 54, having enlarged threaded portions 55, are secured by screws 56 to extend vertically below and transverse to the longitudinal dimension of insulating panel 51. A plurality of buss bars or signal mixing busses 57 are supported by insulating member 54 a short distance below the bottom surface of panel 51 and extend the entire length of the panel.

Flexible, tightly wound coil springs 58 are secured at one end by insulating panel 51. The free end of springs 58 extend perpendicularly downward from panel 51. As shown in FIGS. 2 and 5, several such coil springs are disposed transverse to the longitudinal direction insulating panel 51, generally below each key assembly and offset a short distance from buss bars 57. In addition, there is one coil spring in the longitudinal direction of panel 51 for each key assembly to thereby form a plurality of transversely spaced longitudinally extending rows. Coil springs 58 are preferably closely wound from small diameter Phosphor bronze wire for flexibility, and are gold clad for increased electrical conductivity and low contact potential. The free ends of each set of transversely spaced coil springs are physically connected together by insulating member 60. A plurality of holes, undersized with respect to the diameter of the coil springs 58, provide a secure mechanical bond between insulating member 60 and coil springs 58.

A tie-bar portion 61 substantially reduced in diameter and integral with insulating member 60, is joined to locking portion 62, adapted to provide an interlocking coupling with lever arm 70. As best shown in FIG. 4, generally V-shaped keyway 65 opens into a circular apex to provide an interlocking coupling with locking portion 62. In an alternate embodiment shown in FIG. 7, tie-bar portion 61 of insulating member 60 is integrally joined with a flat disc-shaped portion 63 having aperture 64 therein, which aperture may be conveniently interlocked with a mating pin member on the lower portion of lever means 70. To this end modified lever means 170 (FIG. 8) has a dimpled dowel member 165 located on the bottom portion thereof. Lever means 170 has a molded plastic or rubber cap 172 secured to a generally circular top portion to provide sound deadening when engaging the key assembly. Insulating member 60, along with tie-bar portion 61 and the locking portion is preferably molded as an integral unit from a relatively flexible plastic material such as polyethylene, polyvinyl chloride, or neoprene rubber.

There is one lever means 70 associated with each key assembly, interlocked with each insulating member 60 so as to provide mechanical coupling with a corresponding set of coil springs. Lever means 70 includes an offset, generally horizontal portion 71 having a slot therein adapted to receive sound deadening material 72 such as felt or a pliable plastic material. Chassis portion 20 has a plurality of openings near the front marginal edge thereof to allow one arm of lever means 70 to extend downwardly for interlocking coupling with the tie-bar provided by insulating member 60. As best illustrated in FIG. 4, a longitudinally extending rod 73, secured to chassis portion 20 by brackets 75, extends through the pivotal points of lever means 70. Horizontally extending off-center portion 71 of the upper arm of lever means 70 is of such a width and height to fit within channel-shaped arms 14a and 14b without making physical contact with side portions 32. A small nominal clearance may be provided between sound deadening material 72 and the upper portion of channels 14a and 14b.

As shown in FIG. 5, wherein a key assembly is illustrated in its extreme downward portion in abutment with stop member 37, a bearing surface is provided between the top inner surface of channel-shaped arm 14b and sound deadening material 72. Since this bearing point is horizontally disposed in a position which is off-center with respect to its pivotal point, lever means 70 pivots about rod 73, causing its lower arm to move forward to provide a forward translational motion to insulating member 60. The lower portion of the springs 58, positioned on the opposite side of the mixing busses, are imparted with a like translational movement. Tie-bar portion 61 of insulating member 60 is flexed when the rotation of lever means 70 causes the lower extending arm to move in an arcuate path to compensate for the vertical component of such movement. Such flexing allows the free ends of springs 58 to be translated in a substantially horizontal plane so that portions of the springs adjacent to mixing busses 57 make firm, positive contact without a sliding or rubbing action and without any vertical extension of the springs. This eliminates arcing and contact wear to insure noiseless switching and long operating life. Upon release of the key assemblies they are biased to their normal upward position and springs 58 return to their vertical position to break the electrical contact. Because of the flexible coupling provided by tie-bar portion 61 of insulating member 60, the springs 58 are translated in the same plane as the circuit-making switching action. Thus, quick-acting, noiseless circuit making and circuit breaking is provided with a minimum of manual keyboard pressure. Further, because of the flexibility of the coil springs and of the tie-bar coupling, it is not necessary that individual groups of coil springs 58 and associated insulating members 60 be in exact transverse alignment with the plane of rotation of lever means 70, or be located immediately below individual key assemblies. This allows ease of assembly of the unit and interchangeability of parts without requiring close structural tolerances. Proper switching action is obtained even though panel 51 and the coil springs located thereon may vary longitudinally with respect to the key assemblies.

As best seen from FIG. 3, three mixing busses are disposed parallel to one another and are supported by insulating members 54 to extend along the length of panel 51. Grommets 52 are regularly spaced along the length of the panel and engage chassis portion 20 to provide a cushioned mounting between the panel and the chassis. Because of the extensive longitudinal dimensions of panel 51 and chassis 10 and because of their relative differences in temperature coefficients of expansion, grommets 52 are preferably rubber or a similar flexible material. This allows thermal expansion of panel 51 relative to chassis 10 without cracking and buckling.

Of the three mixing busses shown, two are illustrated as small diameter metal rods having sufficient rigidity to function as fixed contacts for the switching arrangement described. Preferably they are clad with a highly conductive metal such as gold to increase conductivity and to reduce contact resistance. The third mixing buss is shown with a coating of insulating material 59. This material may be vinyl plastic or silicon rubber, impregnated with graphite or carbon, to provide a given amount of resistivity between the springs and the mixing busses. This resistivity may range from zero ohms to a selected high value, or may be variable with contact pressure to provide a degree of volume control as the manual pressure applied to the key assemblies is varied. The resilience of such material provides additional noise deadening during switching. It is to be understood from the foregoing that any number of mixing busses may be employed as the fixed switch contacts, and may utilize various combinations of the mentioned structural features, not limited by the specific mixing buss combinations illustrated.

The top surface of insulating panel 51, with a representative plated or etched circuit pattern disposed thereon, is shown in FIG. 6. Conductors 80 interconnect a plurality of plated or etched eyelets and feedthrough apertures of the type commonly employed in printed circuit practice. These eyelets receive leads of resistors located on the opposite surface of the panel 51 and are soldered in position. Plated or etched eyelets 81 receive the fixed end of coil springs 58, which are also soldered into position. Terminal portions 82 further provides means for interconnection with individual tone generators of the system. As shown in FIG. 7, a plurality of upstanding pins 83 extend through the panel and are soldered to terminals 82. Resistors 85 are disposed on the lower surface of the panel, with leads extending there-through soldered to selective ones of the eyelets and associated interconnecting conductors 80. For the three-buss panel shown, conductors 80 provide octave-to-octave coupling for three octaves. However, to lesser or greater degrees, circuit intercoupling and signal mixing of selective tone generators can be achieved to provide a desirable musical effect by selection of other plated or etched circuit patterns and resistor interconnections.

While the invention has been described more or less precisely as to details of construction, it is to be understood that modifications and variations of the novel features disclosed may be achieved by those skilled in the art without departing from the spirit and scope of the invention set forth in the appended claims.

I claim:

1. A key switch assembly for use in an electronic organ including in combination, a substantially horizontally disposed keyboard chassis, said chassis including a plurality of elongated key assemblies supported for pivotal movement in a vertical direction, a plurality of lever means pivotally mounted on said chassis and individually connected to said key assemblies so that operation of a key causes arcuate movement of the associated lever means in a vertical plane, an insulating panel supported by said chassis and having a plurality of circuit conductors disposed thereon, a plurality of fixed signal conductors insulatingly supported in spaced relationship with respect to said panel, a plurality of elongated coil springs each having first and second substantially coaxial ends and intermediate portions between said ends, said first ends of said coil springs being supported on said panel and electrically joined with selected ones of said circuit conductors, said intermediate portions of said coil springs extending normal to said panel and in close proximity to said signal conductors, and a plurality of insulating members joining said second ends of said coil springs with said lever means, said insulating members each having an elongated body portion fixedly secured to said second ends of selected coil springs, a flexible portion extending from said body portion, and a connecting portion securing said flexible portion to said lever means, whereby arcuate movement of said lever means is transmitted through said flexible portions of said insulating members to provide translational movement of said body portions thereof which is imparted to said second ends of said coil springs to stretch said coil springs about said signal conductors and thereby bring said coil springs into positive contact with said signal conductors.

2. A key switch assembly for electronic organs including in combination, a substantially horizontally disposed keyboard chassis, said chassis including a plurality of elongated key assemblies pivotally supported near one end for movement in a vertical direction, a plurality of lever means having arms extending vertically above and below a fulcrum point at the horizontal surface of said chassis, with each said lever means adapted to coact with individual key assemblies for arcuate movement in a vertical plane, an insulating panel having a plurality of etched circuit conductors disposed on one major surface thereof mounted parallel to and below said chassis, a plurality of fixed sig-

nal mixing busses insulatingly supported in spaced relationship from the other major surface of said panel, a plurality of elongated coil springs each having first and second substantially coaxial ends, said coil springs extending normal to said other major surface in close proximity to said mixing busses, with said first end of said coil springs projecting through apertures in said panel and electrically joined with selected ones of said etched circuit conductors, and a plurality of horizontally disposed insulating members joining said second ends of selected coil springs with the downwardly extending arms of said lever means, said insulating members each having a first portion with vertically disposed apertures therein to fixedly receive said second ends of selected coil springs, a second portion to provide locking engagement with the downwardly extending arms of said lever means, and a flexible intermediate portion of reduced cross-section forming a tie-rod to link said first portion and said lever arm engaging portion, whereby arcuate movement of said lever arms imparts translational movement to said second ends of said coil springs to thereby bring them into positive contact with said mixing busses.

3. A key switch assembly including in combination, a substantially horizontally disposed keyboard chassis, said chassis including a plurality of elongated key assemblies pivotally supported near one end for movement in a vertical direction, a plurality of lever means having arms extending vertically above and below a fulcrum point at the horizontal surface of said chassis, with each said lever means adapted to coact with individual key assemblies for arcuate movement in a vertical plane, an insulating panel having a plurality of plated circuit conductors disposed on one major surface thereof mounted parallel to and below said chassis, a plurality of horizontally disposed buss bars insulatingly supported from the other major surface of said panel, with at least one of said buss bars having a coating of flexible carbon containing material, a plurality of elongated coil springs extending perpendicular to said panel in close proximity to said buss bars, with one end of said coil springs extending through apertures in said panel and electrically joined with selected ones of said plated circuit conductors, and a plurality of horizontally disposed insulating members joining the other end of said coil springs with the downwardly extending arms of said lever means, said insulating members having a first portion with vertically disposed apertures therein to receive said other ends of selected ones of said coil springs, a second portion to provide locking engagement with the downwardly extending arms of said lever means, and a flexible intermediate portion of reduced cross-section forming a tie rod between said first portion and said lever arm engaging portion, whereby arcuate movement of said lever arms imparts translational movement to said other ends of said coil springs to thereby complete an electrical circuit between said contact members and said plated circuit conductors.

4. A key switch assembly for electronic musical instruments including in combination, a keyboard and chassis having a substantially flat horizontally disposed portion, said chassis including a plurality of elongated key assemblies pivotally supported near one end for movement in a vertical direction, a plurality of lever means having a fulcrum point in the plane of the horizontal portion of said chassis means, each said lever means having a first arm extending vertically below the horizontal surface of said chassis and a second arm extending vertically above the horizontal surface of said chassis, with said second arm having a horizontally extending portion containing a vertically extending noise deadening member adapted to coact with individual ones of said key assemblies for arcuate movement in a vertical plane, an insulating panel having a plurality of plated circuit conductors disposed on one major surface thereof and mounted parallel to and below the horizontal portion of said chassis, a plurality of buss bars insulatingly supported in spaced rela-

tionship with respect to the other major surface of said panel, a plurality of elongated coil springs each having first and second ends, said coil springs extending normal to said other major surface in close proximity to said buss bars, with said first ends of said coil springs extending through apertures in said panel and electrically joined with selected ones of said plated circuit conductors, and a plurality of insulating members each having a resilient portion forming a tie bar for flexible coupling between said downwardly extending lever arms and the other ends of selected coil springs, each of said insulating members having a first body portion fixedly secured to said second ends of selected coil springs, a second connecting portion secured to one of said lever arms, and a flexible intermediate portion joining said first and second portions, so that vertical depression of said key assemblies imparts horizontal translational movement to said other ends of said coil springs, said coil springs being pulled and stretched across said buss bars to thereby complete an electrical circuit between said contact members and said buss bars.

5. A key switch assembly including in combination, a substantially horizontally disposed keyboard chassis, said chassis including a plurality of elongated key assemblies pivotally supported near one end for movement in a vertical direction, said key assemblies including an elongated channel-shaped arm having a flanged portion adapted to engage fingers upstanding on the front marginal edge of said chassis to limit the vertical movement of said key assemblies, a plurality of lever means having a fulcrum point near the front marginal edge of said chassis, said lever means each having a first arm extending vertically below the horizontal surface of said chassis and a second arm extending vertically above the horizontal surface of said chassis, with said second lever arm having a horizontally extending portion containing noise deadening material adapted to engage said channel-shaped arm and to coact with said key assembly for arcuate movement in a vertical plane, an insulating panel having a plurality of plated circuit conductors disposed on one major surface thereof mounted parallel to and below said chassis, a plurality of fixed electrical contact members insulatingly supported from the other major surface of said panel, a plurality of elongated coil springs extending perpendicular to said other major surface in close proximity to said contact members, with one end of said coil springs extending through apertures in said panel to make electrical contact with selected ones of said plated circuit conductors, and a plurality of insulating members each having a resilient portion forming a tie-bar to provide flexible coupling between said second lever arms and the other end of selected coil springs, each of said insulating members having a first body portion fixedly secured to said other ends of selected coil springs, a second portion mechanically connected to one of said lever arms, and a flexible intermediate portion of reduced cross-section connecting said first and second portions, so that vertical depression of said key assemblies imparts horizontal translational movement to the free ends of said coil springs to thereby complete an electrical circuit between said contact members and said plated circuit conductors.

6. A keyboard assembly including in combination, a generally elongated chassis, said chassis including a horizontal panel section having a series of upwardly projecting longitudinally spaced front key positioning fingers and rear fulcrum forming means, a set of transversely extending longitudinally spaced key assemblies movably supported on said chassis and forming a keyboard, the rear end portion of each key assembly being pivotally mounted on said fulcrum forming means and the front end portion thereof engaging said front key positioning fingers, a plurality of levers pivotally secured to said horizontal panel section, each said lever having an arm extending below said horizontal panel section and an arm extending above said horizontal panel section, with the upwardly extending arm of each said lever coacting with individual ones of said

key assemblies for arcuate movement in a vertical plane, a flat elongated insulating panel mounted with the major surfaces thereof parallel to and below said horizontal panel section, a plurality of signal mixing busses insulatingly supported in spaced relationship with respect to one major surface of said insulating panel, a plurality of elongated resilient coil springs extending vertically from said insulating panel in close proximity to said signal mixing busses, with one end of each said coil springs secured in fixed position by said insulating panel, and a plurality of insulating members each having a resilient portion forming a tie bar flexibly coupling the other end of selected coil springs to the downwardly extending arm of a coacting lever, said insulating members each having a body portion fixedly secured to said other ends of said selected coil springs, a flexible portion extending from said body portion and a connecting portion securing said flexible portion to said arm of one of said levers, whereby arcuate movement of said levers imparts translational movement to said other ends of selected coil springs to thereby make positive electrical contact with said mixing busses.

7. For use with a keyboard having a plurality of key assemblies adapted to coact with lever means to impart arcuate movement thereto, the combination including a flat elongated insulating panel having first and second major surfaces, a plurality of elongated buss bars insulatingly supported at fixed points from said first major surface, a plated circuit pattern including a plurality of conductors and terminal areas disposed on said second major surface, a plurality of apertures of a first size extending between said major surfaces opening into selected portions of said plated circuit pattern, a plurality of apertures of a second size extending to said major surfaces opening into areas not covered by said plated circuit pattern, a plurality of electrical resistors disposed on said first surface having leads extending through selected apertures of said first size and electrically joined to said circuit pattern, a plurality of flexible grommets engaging said apertures of said second size for suspending said panel from said keyboard, a plurality of elongated coil springs disposed perpendicular to said first major surface extending in close proximity to said buss bars, said coil springs having one end engaging selected apertures of said first size and in electrical contact with said plated circuit conductors, and a plurality of insulating members each engaging the other ends of selected coil springs, each said insulating member having a resilient elongated tie rod formed as an integral part therewith, with said tie rods adapted to provide a flexible linkage between said selected coil springs and corresponding lever means.

8. A keyboard assembly including in combination, a generally elongated chassis means, said chassis means including a horizontal panel section having a series of upwardly projecting longitudinally spaced front key-positioning fingers and rear fulcrum-forming means, a set of transversely extending longitudinally spaced key assemblies movably supported upon said chassis means and forming a keyboard, the rear end portion of each key assembly being pivotally mounted upon said fulcrum-forming means and the front end portion thereof engaging said front key-positioning fingers, with said key assemblies having means coacting with said front key positioning fingers to limit the vertical movement thereof, a set of lever means secured to said horizontal panel section, each said lever means having an arm extending below said horizontal panel section and an arm extending above said horizontal panel section, with the upwardly extending arm of each said lever means coacting with individual ones of said key assemblies for arcuate movement in a vertical plane, a generally flat insulating member mounted with the major surfaces thereof parallel to and below said horizontal panel section, a plurality of fixed electrical contacts insulatingly supported from one major surface of said insulating board, a plurality of elongated resilient coil springs extending vertically from said insulating board

11

in close proximity to said fixed contacts, with one end of each said coil springs secured in fixed position by said insulating board, and a plurality of resilient insulating member forming tie bars connecting the other end of selected ones of said coil springs to coact with downwardly extending lever arms of corresponding lever means, each of said resilient insulating members including a first body portion fixedly secured to said other ends of said selected coil springs, a second portion mechanically connected to one of said lever means, and a flexible intermediate portion of reduced cross-section connecting said first and second portions.

5

10

12

## References Cited by the Examiner

## UNITED STATES PATENTS

1,521,793	1/1925	Roe	200—86.5 X
2,567,870	9/1951	Bozak et al.	84—1.01
2,630,503	3/1953	Larsen et al.	200—18
2,641,153	6/1953	Enochs et al.	84—423
2,816,181	12/1957	Mann	84—1.01
2,963,564	12/1960	Cutler et al.	200—153
3,013,188	12/1961	Kohler	317—101
3,022,447	2/1962	Henss	317—101

DAVID J. GALVIN, *Primary Examiner.*