

March 30, 1954

F. E. DUEKER

2,673,381

QUICK LACE SHOELACE TIGHTENER

Filed Dec. 13, 1951

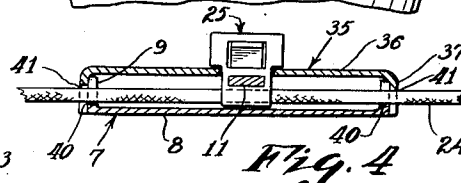
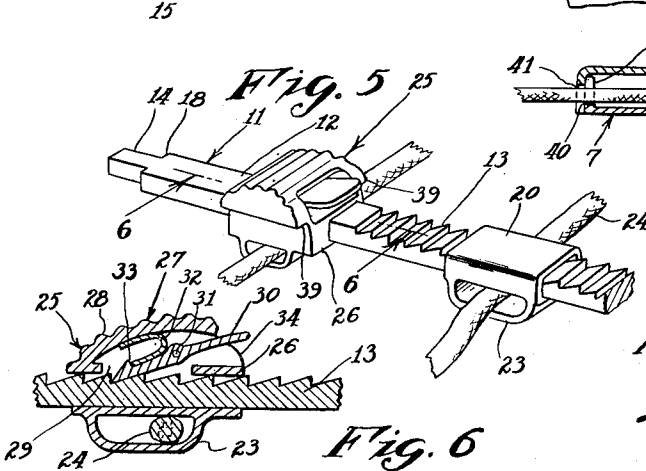
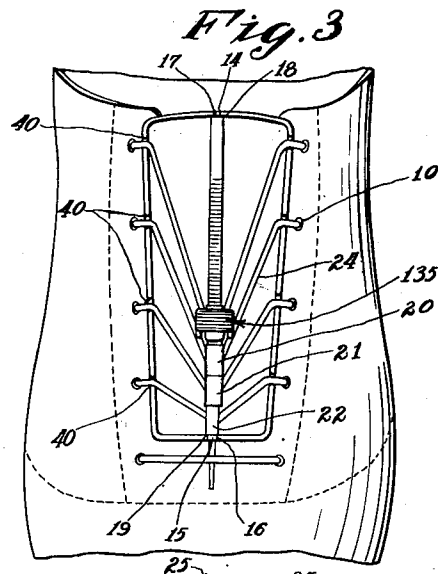
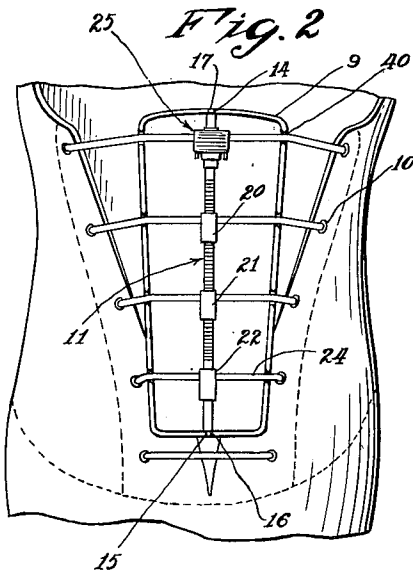
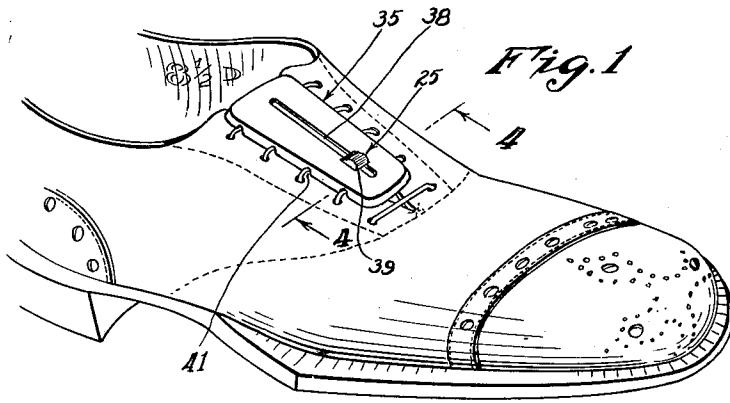

INVENTOR.  
FRED E. DUEKER  
BY  
L. S. Saulsbury  
ATTORNEY

# UNITED STATES PATENT OFFICE

2,673,381

## QUICK LACE SHOELACE TIGHTENER

Fred E. Dueker, Fort Bliss, Tex.

Application December 13, 1951, Serial No. 261,486

5 Claims. (Cl. 24-140)

1

This invention relates to improvements in shoe closures.

It is the principal object of this invention to provide a shoe closure whereby the shoe can be quickly and easily tightened and untightened and which eliminates the conventional tying and untying of knots.

A further object of the present invention is to provide a shoe closure that can be operated with one hand and of such simplicity and ease in operation that the shoe may be tightened or untightened by children without assistance of adults.

A still further object of the present invention is to provide a shoe closure that eliminates the tying of knots in the conventional manner and thereby eliminates accidents due to untied shoe lace knots.

A still further object of the present invention is to provide a shoe closure that can be adjusted to the wearer's comfort and which will retain such adjustment until the shoe is removed.

A still further object of the present invention is to provide a shoe closure which is fixedly secured to the shoe uppers at all times and which includes novel means for tightening and untightening said shoe uppers.

Other objects of the present invention are to provide a shoe closure which is of simple construction, easy to operate, inexpensive to manufacture, pleasing in appearance and efficient in operation.

For a better understanding of the invention, reference may be had to the following detailed description, taken in connection with the accompanying drawing, in which:

Fig. 1 is a perspective view of the shoe closure in position on the shoe uppers;

Fig. 2 is a top plan view of the shoe closure with the cover plate removed to illustrate the position of the moving parts when the shoe is untightened;

Fig. 3 is a top plan view of the shoe closure with the cover plate removed to show the position of the moving parts when the shoe uppers are tightened on the foot of the wearer;

Fig. 4 is a vertical section taken along line 4-4 of Fig. 1;

Fig. 5 is an enlarged perspective view of a portion of the shoe closure;

Fig. 6 is a vertical section taken along the line 6-6 of Fig. 5.

Referring now to the figures, a base plate 7 consisting of a rectangular base 8 and an upwardly extending flange 9 extending around the

2

periphery thereof is adapted to be placed over the shoe uppers, the upwardly extending flange 9 being bordered by the shoe lace eyelets 10 in the manner shown in Fig. 3. The longitudinal sides of the base plate 7 taper slightly downwardly and the lower surface thereof is slightly curved to fit the contour of the foot. The rectangular shaft 11 consisting of a smooth portion 12 and a saw-toothed portion 13 is disposed along the longitudinal axis of said base plate 7, the ends 14 and 15 of the shaft 11 being adapted to rest in holes 16 and 17 located at the top of the upwardly extending flange 9 at the longitudinal axis thereof. Shoulders 18 and 19 prevent longitudinal displacement of the shaft 11 relative to the base plate 7. Rectangular members 20, 21 and 22 are located along the toothed portion 13 of the shaft 11 and are adapted to ride freely along said toothed portion 13. The lower portions of the rectangular members 20, 21 and 22 have integrally formed loops 23 adapted to receive the shoe lace 24.

An operating knob 25 consisting of a central portion 26 and an upper portion 27 is located along the upper portion of the shaft 11 above the rectangular members 20, 21 and 22. The central portion 26 of the operating knob 25 is adapted to ride along the shaft 11 in a manner similar to rectangular members 20, 21 and 22. The upper portion 27 of the operating knob 25 consists of a shell 28, said shell 28 being roughly semi-circular in cross-section, a ratchet 30 and a U-spring 32. The center of the ratchet 30 is pivotally connected to the side walls of the shell 28 in conventional manner by means of a pin 31. The lower portion of the ratchet 30 extends downwardly of the central portion 26 through the opening 29, the lower portion of the ratchet 30 being adapted to engage the saw-toothed portion 13. The ratchet 30 is kept in engagement with the saw-toothed portion 13 by means of the use of the U-spring 32. A shoulder 33 located at the lower end of the ratchet 30 prevents displacement of the U-spring 32. The ratchet 30 extends upwardly and outwardly from said shell 28 by means of the opening 34. The lower surface of the operating knob 25 has integrally formed thereto a loop 23 adapted to engage the shoe lace 24.

A cover plate 35 consisting of a cover 36 and a downwardly extending flange 37 located around the periphery of said cover 36 and integrally connected thereto is adapted to snap over the base plate 7 in the manner shown in Fig. 1. The cover 36 is provided with an elongated

3

opening 38 located along the longitudinal axis of said cover 35 and adapted to permit longitudinal movement of the operating knob 25 along the shaft 11. Shoulders 39 of the shell 28 engage the upper surface of said cover 35 and prevent upward displacement of said cover plate 35 relative to said base plate 7.

Openings 40 are located along the longitudinal sides of the upwardly extending flange 9 adjacent the shoe lace eyelets 10, as shown in Fig. 3. Corresponding openings 41 are located in the downwardly extending flange 37 of the cover plate 35 and coincide with the openings 40.

The shoe closure is permanently attached to the shoe by lacing it on with the conventional shoe lace employing the horizontal front lacing method. The shoe lace 24, as is shown in Fig. 3, passes upwardly from the shoe lace eyelet 10 through the openings 40 and 41 in the base plate 7 and cover plate 35 respectively, then passing through the loop 23 of the rectangular member 22 and out the other side of the base plate 7 and cover plate 35 through the openings 40 and 41. In order to provide access to the openings 40 and 41 and the loop 23 when lacing, the various parts of the shoe closure are not assembled until the lacing is complete. When the shoe lace 24 has passed through the openings 40 and 41 and the loops 23 in the manner shown in Fig. 2, the shoe lace is tied in a firm knot near the operating knob and the loose ends of the lace remaining are severed. This lacing is effected with the base plate 7 in the position shown in Fig. 2, while the rectangular shaft 11 and the operating knob 25 and cover plate 35 rest slightly above the base plate 7. During the lacing, the operating knob 25 rests in the elongated opening 38 of the cover plate 35 and moves free of the longitudinal shaft 11, which in turn moves free of the base plate 8. When the lacing is complete, the central portion of the operating knob 25 with the cover plate 35 attached thereto is slid onto the rectangular shaft 11 from the end 14. The rectangular members 20, 21 and 22 are, of course, in their proper place on the rectangular shaft 11 during the operation. After sliding the cover plate 35 and operating knob 25 onto the rectangular shaft 11, the latter is then snapped into place in the base plate 7, the ends 14 and 15 of the rectangular shaft 11 engaging the openings 16 and 17 in said base plate 7.

In operation the shoe is placed on the wearer's foot with the operating knob and rectangular members in the position shown in Fig. 2. The outer end of the ratchet 30 is then pressed downwardly and the operating knob moved downwardly. The movement of the operating knob 25 carries the rectangular members 20, 21 and 22 to the lower end of the rectangular shaft 11, as shown in Fig. 3. The outer end of the ratchet 30 is then released, the U-spring 32 serving to hold the inner end of the ratchet in position on the saw-toothed portion of the rectangular shaft 11. The position of the operating knob 25 may, of course, be adjusted to the comfort of the wearer. To remove the shoe, the foregoing procedure is merely reversed.

It should now be apparent that there has been provided a novel shoe closure which permits the tightening and untightening of shoes with a minimum of effort.

While various changes may be made in the detailed construction, it should be understood that such changes shall be within the spirit and scope

4

of the present invention, as defined by the appended claims:

What is claimed is:

1. A shoe closure comprising a rectangular shaft, a portion of the upper surface of said rectangular shaft being of saw tooth construction, a plurality of rectangular members adapted to slide freely along said saw tooth portion, the lower surface of each of said rectangular sliding members having integrally formed thereto a loop adapted to receive a shoe lace, another rectangular sliding member adapted to slide along said rectangular shaft, above said first mentioned rectangular sliding members, said other rectangular sliding member having integrally formed on the lower surface thereof a loop adapted to receive a shoe lace, the upper portion of said other rectangular sliding member being provided with releasable means for locking said another rectangular member along the saw tooth portion of said rectangular shaft, and a flat rectangular housing for said rectangular shaft, said shaft at each end being fixedly mounted in the ends of said housing, said flat rectangular housing being adapted to rest on the shoe uppers between the shoe lace eyelets and being provided on each side thereof with a series of openings located adjacent said eyelets, said flat rectangular housing being provided with an elongated opening whereby to permit access to said releasable means of said other rectangular sliding member.

2. A shoe closure comprising an elongated rectangular shaft, a portion of the upper surface of said rectangular shaft being of saw tooth construction, three rectangular sliding members adapted to slide freely along said saw tooth portion, each of said three rectangular sliding members having integrally formed to the lower surface thereof a loop adapted to receive a shoe lace, a fourth rectangular sliding member adapted to slide along said saw tooth portion above said three rectangular sliding members and having integrally formed to the lower surface thereof a loop adapted to receive a shoe lace, the upper surface of said fourth rectangular member having integrally formed thereto an enlarged hollow knob, said enlarged hollow knob in the upper wall thereof being provided with a first opening, said enlarged hollow knob in the bottom wall thereof being further provided with a second opening communicating with the interior portion of said fourth rectangular sliding member whereby to provide access to said saw tooth portion, a ratchet located within said knob and pivotally connected to the side walls thereof by means of a pin, the lower portion of said ratchet extending through said second mentioned opening and being adapted to engage the saw tooth portion of said rectangular shaft, the upper portion of said ratchet extending upwardly and outwardly of said enlarged hollow knob by means of said first mentioned opening, spring means located within said enlarged hollow knob adapted to maintain the lower portion of said ratchet in engagement with said saw tooth portion, and a flat rectangular housing for said rectangular shaft, said shaft at each end being fixedly mounted in the ends of said housing, said flat rectangular housing being adapted to rest on shoe uppers between shoe lace eyelets and being provided on each side thereof with a series of openings adjacent said eyelets, said flat rectangular housing being provided with an elongated opening adapted to receive the central portion of said fourth sliding member while preventing the downward displacement of the

5

enlarged hollow head integrally formed thereto, said elongated opening lying above the said rectangular shaft and extending substantially the length thereof.

3. A shoe closure comprising an elongated rectangular shaft, the upper surface of said rectangular shaft being of saw tooth construction along a portion thereof, three hollow rectangular members adapted to slide along the saw tooth portion of said rectangular shaft, each of said hollow rectangular members having integrally formed to the lower surface thereof a loop adapted to receive a shoe lace, a fourth hollow rectangular sliding member adapted to slide along the saw tooth portion of said rectangular shaft above said three rectangular sliding members, the lower surface of said fourth rectangular sliding member having integrally formed thereto a loop adapted to receive a shoe lace, the upper surface of said fourth rectangular member having integrally formed thereto an enlarged hollow knob, said enlarged hollow knob being provided in the upper wall thereof with a first opening, said enlarged hollow knob being further provided in the bottom wall thereof with a second opening communicating with the interior portion of said fourth rectangular sliding member whereby to provide access to said saw tooth portion, a ratchet located within said knob and pivotally connected to the side walls thereof by means of a pin, the lower portion of said ratchet extending through said second mentioned opening and being adapted to engage the saw tooth portion of said rectangular shaft, the upper portion of said ratchet extending upwardly and outwardly of said enlarged hollow knob by means of said first mentioned opening, a U-shaped spring located within said enlarged hollow knob between the upper interior surface thereof and the lower portion of said ratchet whereby to maintain said lower portion of said ratchet in normal engagement with said saw tooth portion, the lower portion of said ratchet being provided with a shoulder whereby to maintain said U-shaped spring against displacement relative to said ratchet, and a flat rectangular housing for said rectangular shaft, said shaft at each end being fixedly mounted in the ends of said housing, said flat rectangular housing being adapted to rest on shoe uppers between shoe lace eyelets and being provided on each side thereof with a series of openings adjacent said eyelets, said flat rectangular housing being provided on the upper surface thereof along the rectangular axis thereof with an elongated opening adapted to receive the central portion of said fourth sliding member while preventing the downward displacement of the enlarged hollow head integrally formed thereto, said elongated opening lying above the said rectangular shaft and extending substantially the length thereof.

4. A shoe closure comprising a rectangular shaft, a portion of the upper surface of said rectangular shaft being of saw tooth construction, said shaft being provided at each end with a shoulder, three hollow rectangular members adapted to slide along the saw tooth portion of said rectangular shaft, each of said hollow rectangular members having integrally formed to the lower surface thereof a loop adapted to receive a shoe lace, a fourth hollow rectangular sliding member adapted to slide along the saw tooth portion of said rectangular shaft above said three rectangular sliding members, the lower surface of said fourth rectangular sliding

6

member having integrally formed thereto a loop adapted to receive a shoe lace, the upper surface of said fourth rectangular member having integrally formed thereto an enlarged hollow knob, said enlarged hollow knob being provided in the upper wall thereof with a first opening, said enlarged hollow knob being further provided in the bottom wall thereof with a second opening communicating with the interior portion of said fourth rectangular sliding member whereby to provide access to said saw tooth portion, a ratchet located within said knob and pivotally connected to the side walls thereof by means of a pin, the lower portion of said ratchet extending through said second mentioned opening and being adapted to engage the saw tooth portion of said rectangular shaft, the upper portion of said ratchet extending upwardly and outwardly of said enlarged hollow knob by means of said first mentioned opening, a U-shaped spring located within said enlarged hollow knob between the upper surface thereof and the lower portion of said ratchet, the lower portion of said ratchet being provided with a shoulder whereby to maintain said U-shaped spring against displacement and a flat rectangular housing for said rectangular shaft, said flat rectangular housing consisting of a base plate, said base plate being adapted to rest on shoe uppers between shoe lace eyelets, an upwardly extending flange integrally connected around the periphery of said base plate, the longitudinal sides of said upwardly extending flange being provided with a series of openings located adjacent said eyelets, the lower surface of said base plate being curved concavely, the longitudinal sides of said upwardly extending flange tapering slightly towards each other, a cover plate, said cover plate being provided around the periphery thereof with a downwardly extending flange integrally formed thereto, said downwardly extending flange being adapted to fit snugly around said upwardly extending flange and being provided along the longitudinal sides of said downwardly extending flange with a series of openings coinciding with the said openings in said upwardly extending flange, said cover plate being provided with an elongated opening adapted to receive the central portion of said fourth sliding member while preventing the downward displacement of the enlarged hollow head integrally formed thereto, said elongated opening lying above the said rectangular shaft and extending substantially the length thereof, the upwardly extending flange of said base plate being provided with openings at each end thereof, said openings being located along the longitudinal axis of said base plate, said openings being located near the top of said upwardly extending flange, and receiving therein the ends of the said rectangular shaft, said shoulders located at the ends of said rectangular shaft preventing longitudinal displacement of said shaft relative to said base plate.

5. A shoe closure comprising a shaft having a saw tooth portion, a freely slidable member adjustable along the shaft and having a shoe lace receiving portion, another sliding member on said shaft also having a shoe lace receiving portion, releasable means on said other sliding member engageable with the saw tooth portion of the shaft to retain the sliding member in its adjusted position thereon, a supporting housing for retaining said shaft therewithin and inclosing said sliding members so as to permit movement thereof, said housing being adapted to rest upon the

7

shoe between the shoe lace eyelets thereof, the ends of said shaft being fixedly mounted in the ends of said housing, said supporting housing having openings adjacent the respective shoe lace eyelets, and shoe lace means extending through the openings of the supporting housing and the shoe lace receiving portions of the respective sliding members.

FRED E. DUEKER. 10

8

## References Cited in the file of this patent

## UNITED STATES PATENTS

Number	Name	Date
317,528	Forbes -----	May 12, 1885
914,897	Thomas -----	Mar. 9, 1909

## FOREIGN PATENTS

Number	Country	Date
124,450	Germany -----	Oct. 26, 1901