



(19) **United States**

(12) **Patent Application Publication**
HOWARD

(10) **Pub. No.: US 2001/0008725 A1**

(43) **Pub. Date: Jul. 19, 2001**

(54) **CURRENT COLLECTOR FOR LITHIUM ELECTRODE**

Publication Classification

(76) Inventor: **WILLIAM G. HOWARD,**
ROSEVILLE, MN (US)

(51) **Int. Cl.⁷** **H01M 2/26; H01M 4/54;**
H01M 4/62; H01M 2/18

Correspondence Address:
GIRMA WOLDE-MICHAEL
MEDTRONIC INC
7000 CENTRAL AVENUE NE
MINNEAPOLIS, MN 55432 (US)

(52) **U.S. Cl.** **429/94; 429/219; 429/231.5;**
429/232; 429/136; 429/211;
429/245; 429/217

(*) Notice: This is a publication of a continued prosecution application (CPA) filed under 37 CFR 1.53(d).

(57) **ABSTRACT**

(21) Appl. No.: **09/067,208**

An electrochemical cell and corresponding electrode assembly are described in which an alkali metal anode and a cathode assembly are wound together in a unidirectional winding having substantially straight sides such that the winding will fit into a prismatic cell. The anode and cathode are preferably arranged in the winding to provide for even utilization of reactive material during cell discharge by placing cathode and anode material in close proximity throughout the electrode assembly in the proportions in which they are utilized. An anode current collector having a length or height shorter than at least one of the length or height of the cathode current collector or alkali metal strips operatively associated with the anode current collector is also described.

(22) Filed: **Apr. 28, 1998**

Related U.S. Application Data

(60) Continuation-in-part of application No. 08/430,532, filed on Apr. 27, 1995, now Pat. No. 6,051,038, which is a division of application No. 08/155,410, filed on Nov. 19, 1993, now Pat. No. 5,439,760 and which is a non-provisional of provisional application No. 60/072,223, filed on Jan. 7, 1998.

Fig. 1A

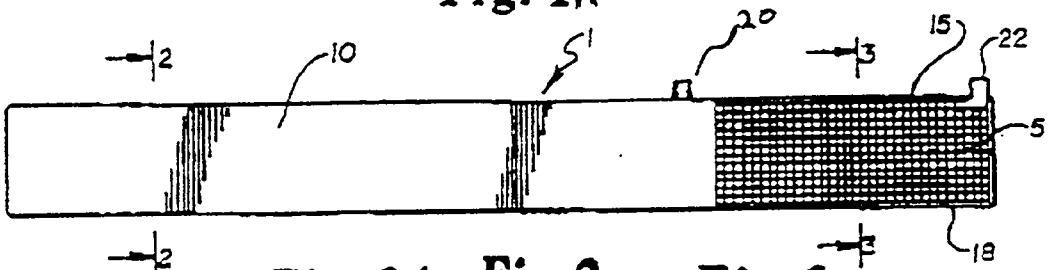

Fig. 5

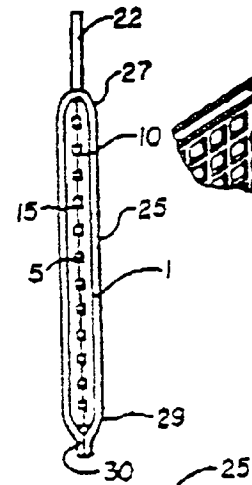

Fig. 3A Fig. 2

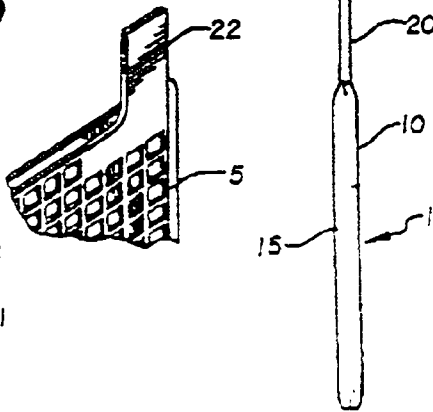

Fig. 3

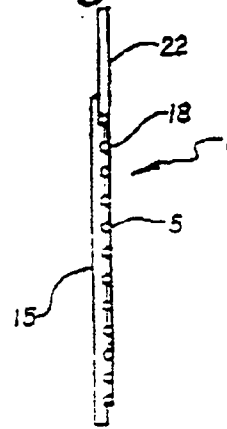

Fig. 4

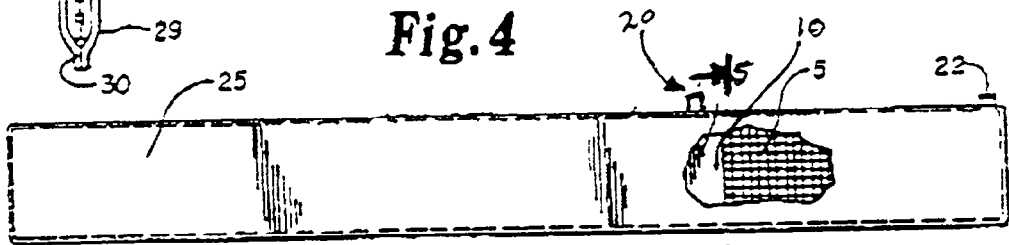

Fig. 7

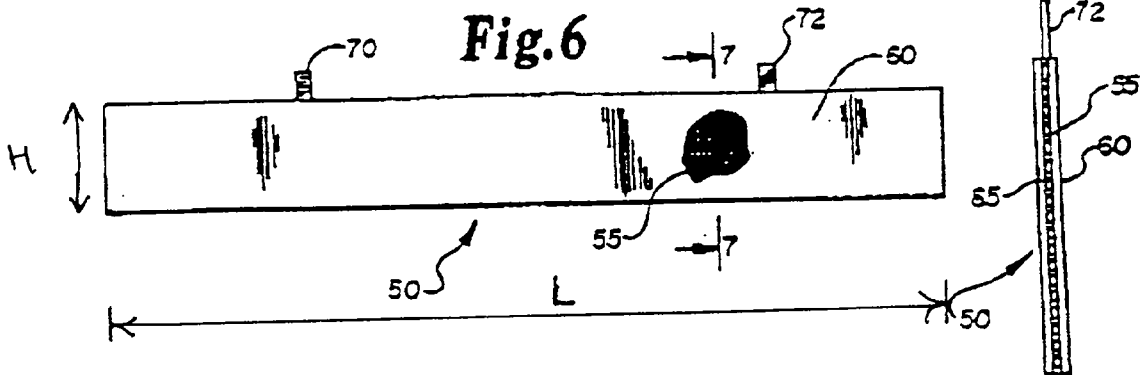

Fig. 8

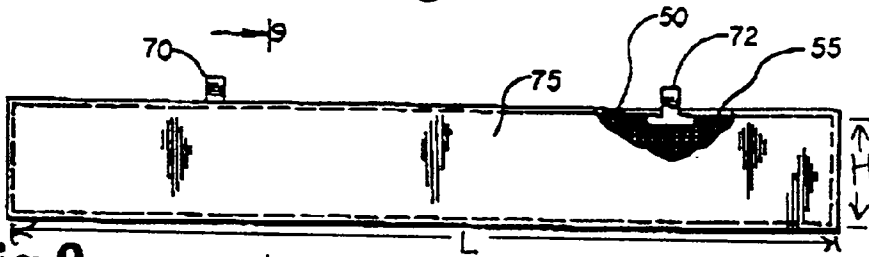

Fig. 9

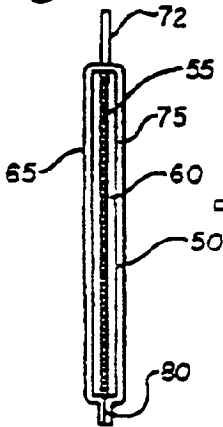

Fig. 11

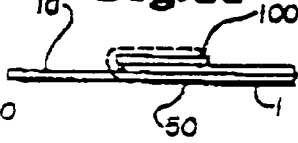

Fig. 12

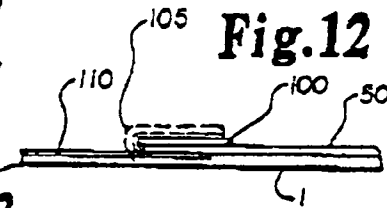

Fig. 13

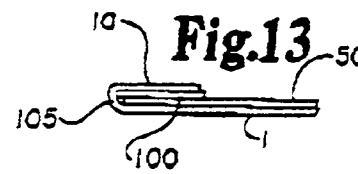

Fig. 10



Fig. 14

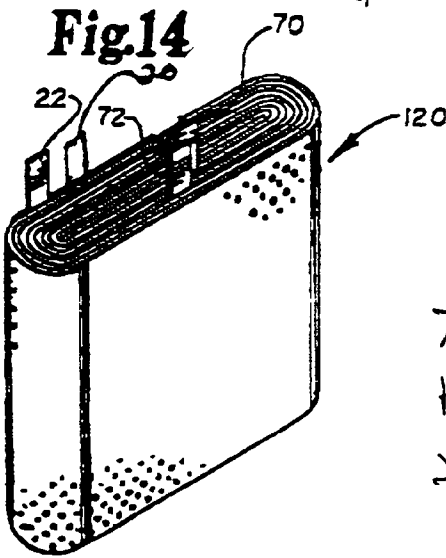

Fig. 13

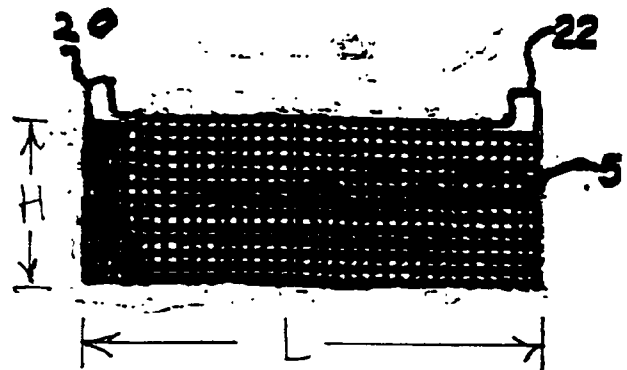

Fig. 15

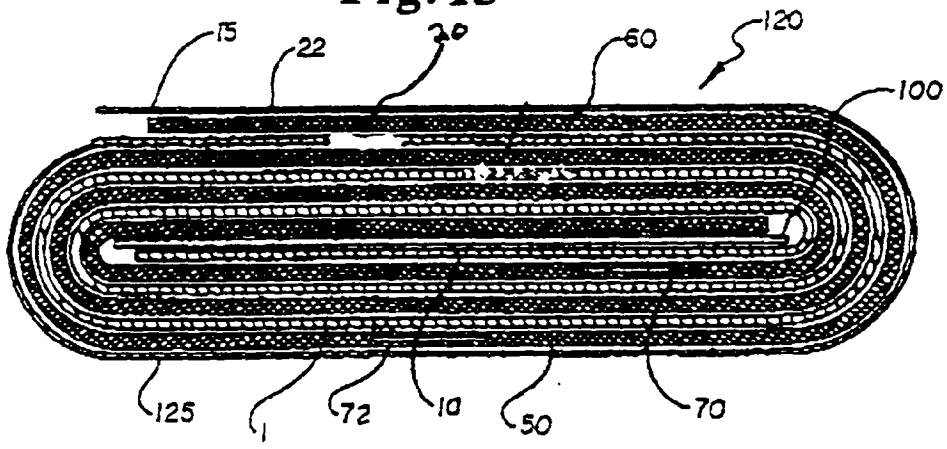

Fig. 17

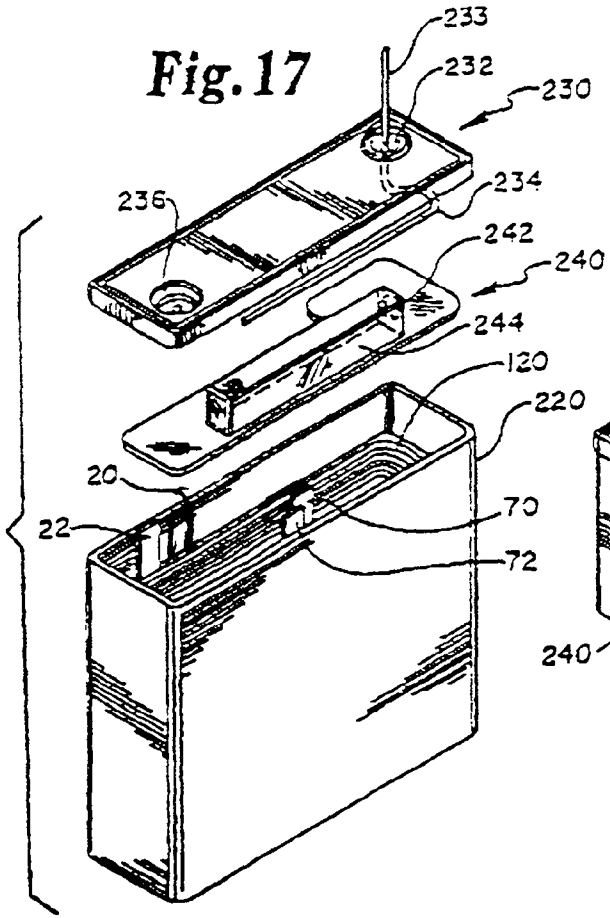

Fig. 18

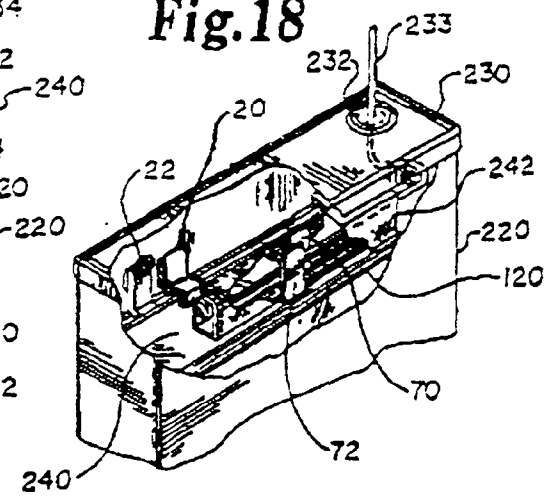

Fig.16

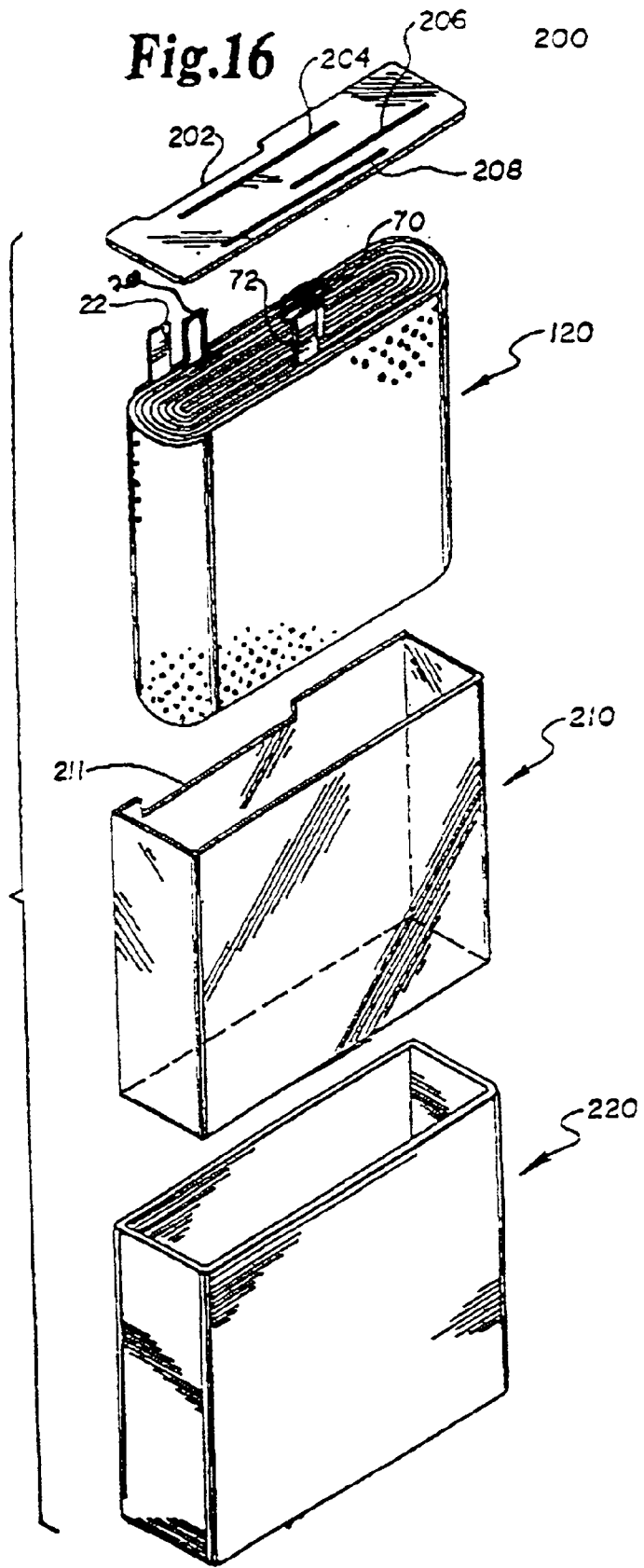

Fig. 19

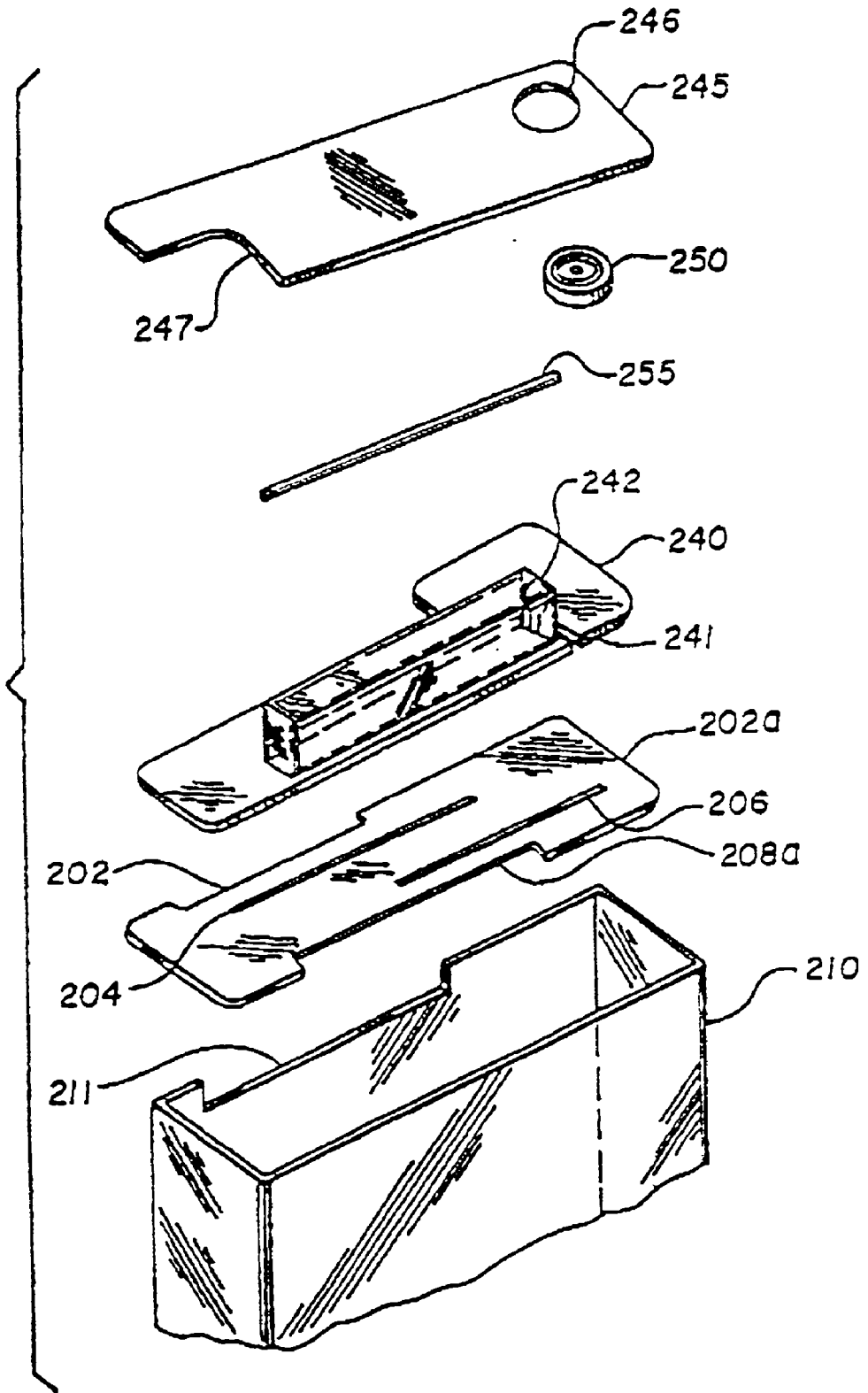

Fig. 20

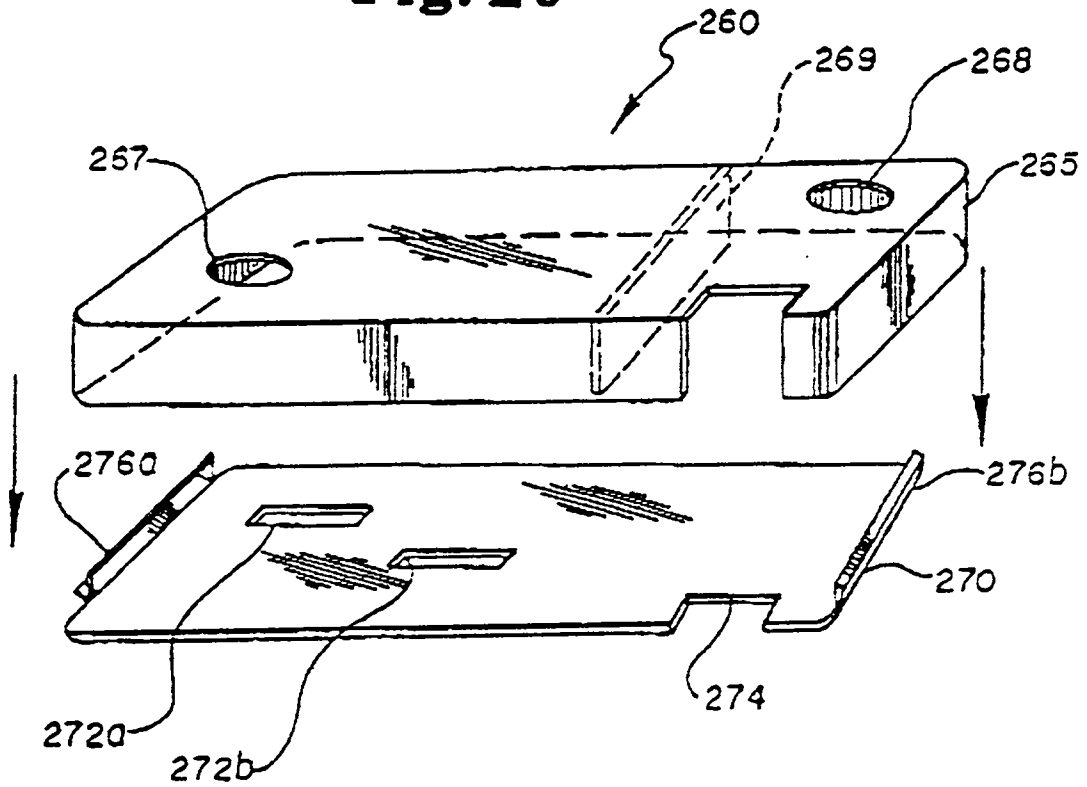

Fig.21

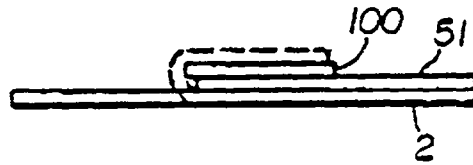
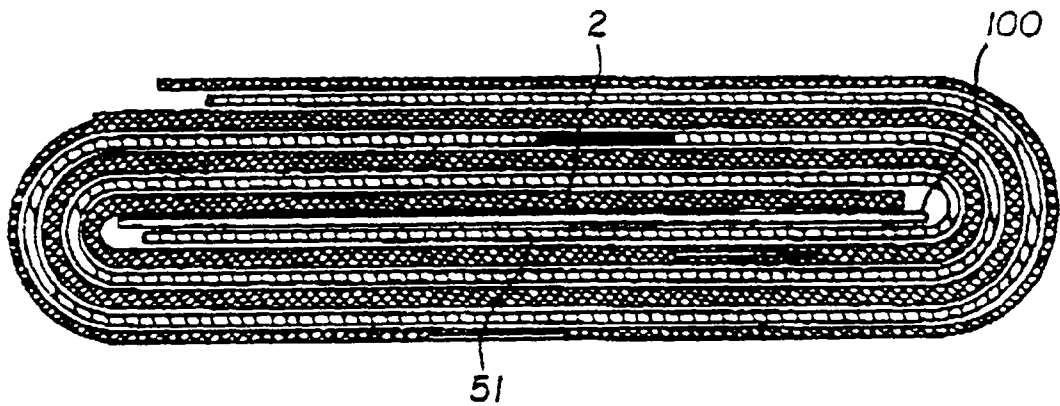

Fig.22



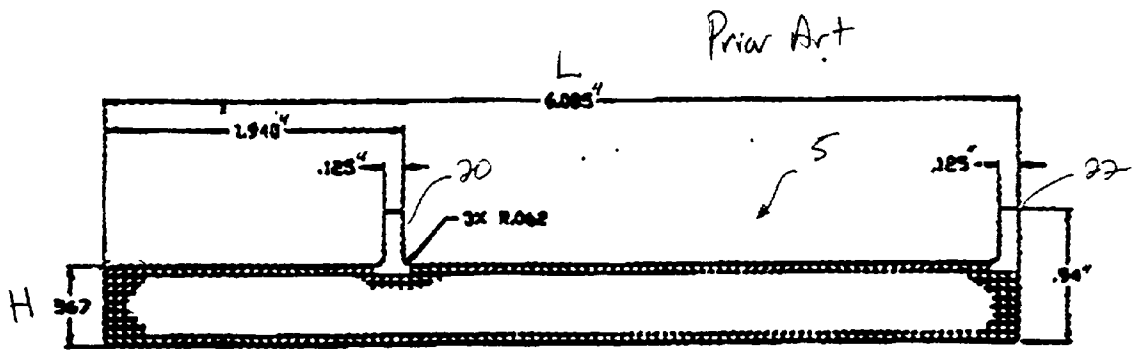

Fig. 23

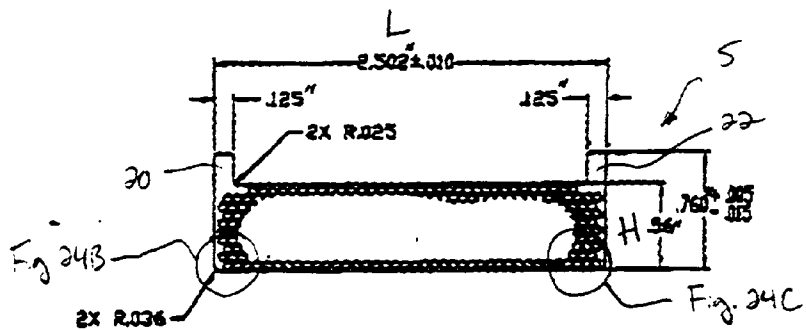

Fig. 24A

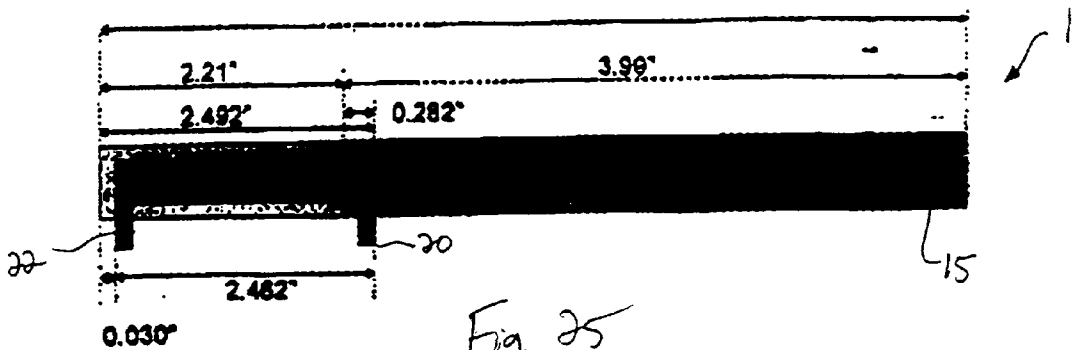

Fig. 25

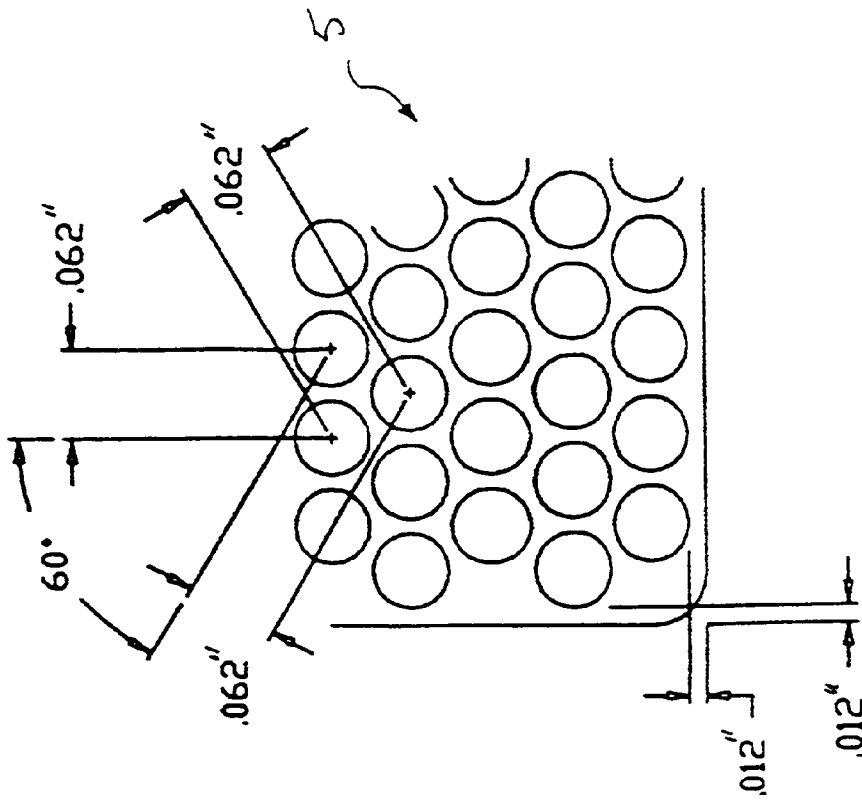

Fig. 24B

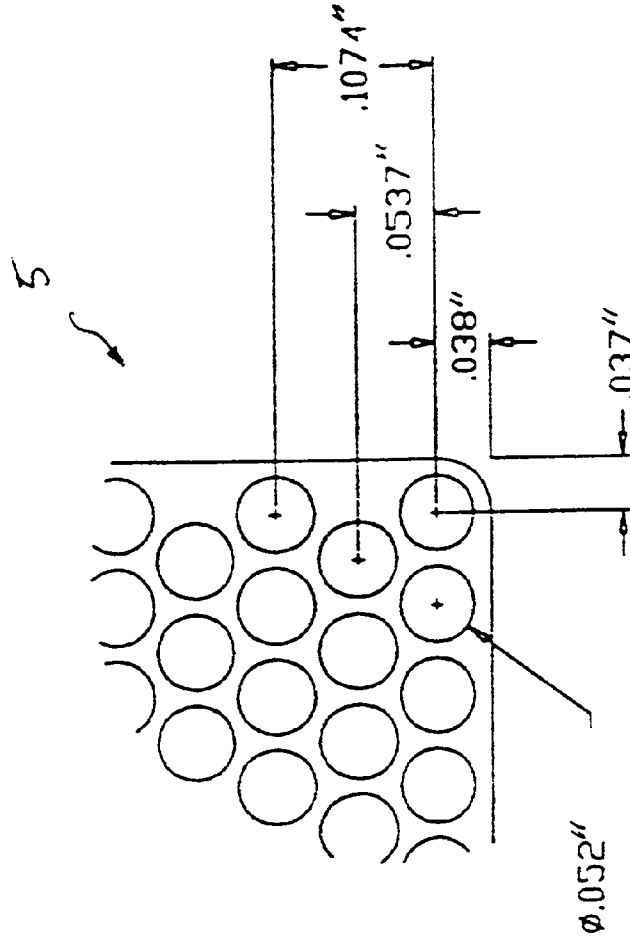

Fig. 24C

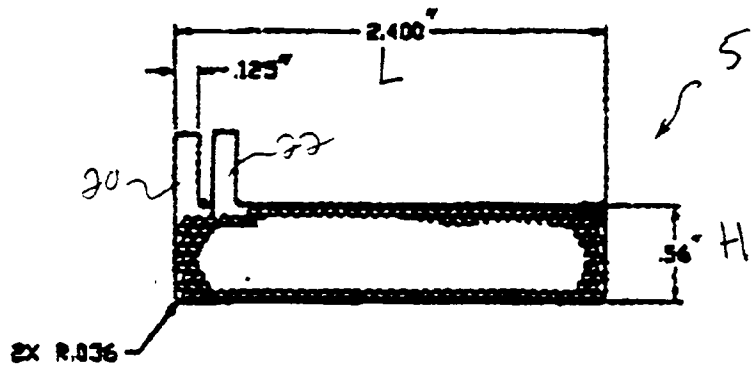

Fig 26

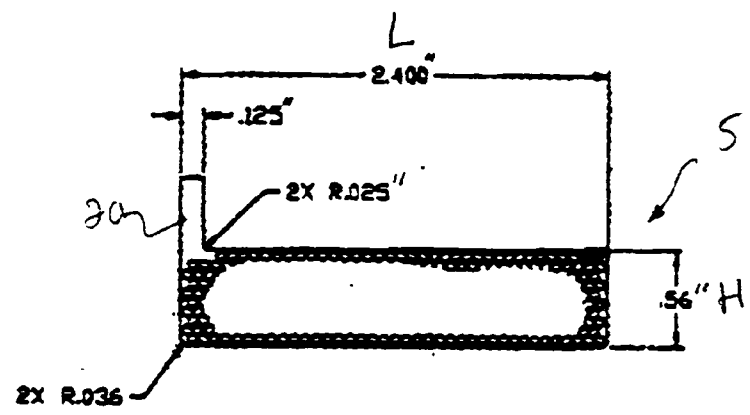

Fig. 27

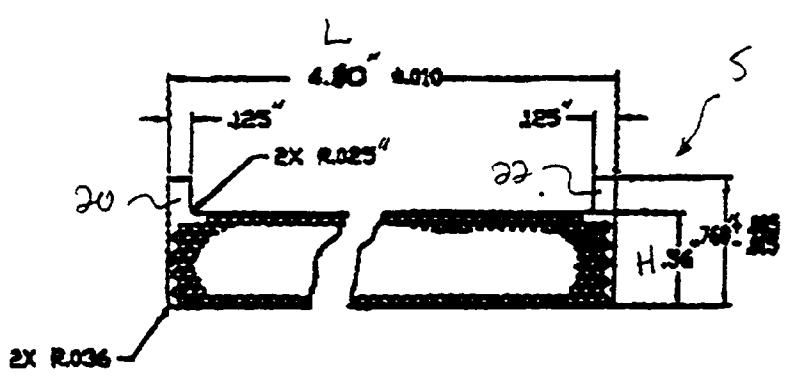

Fig. 28

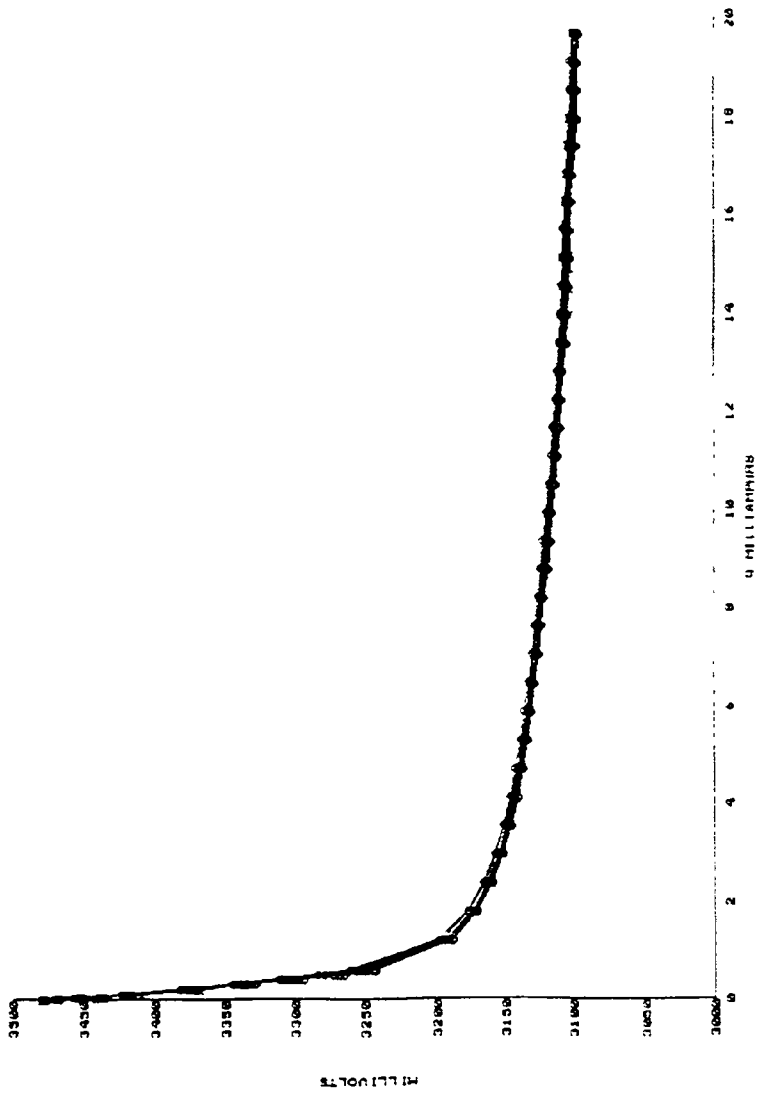

Fig. 29

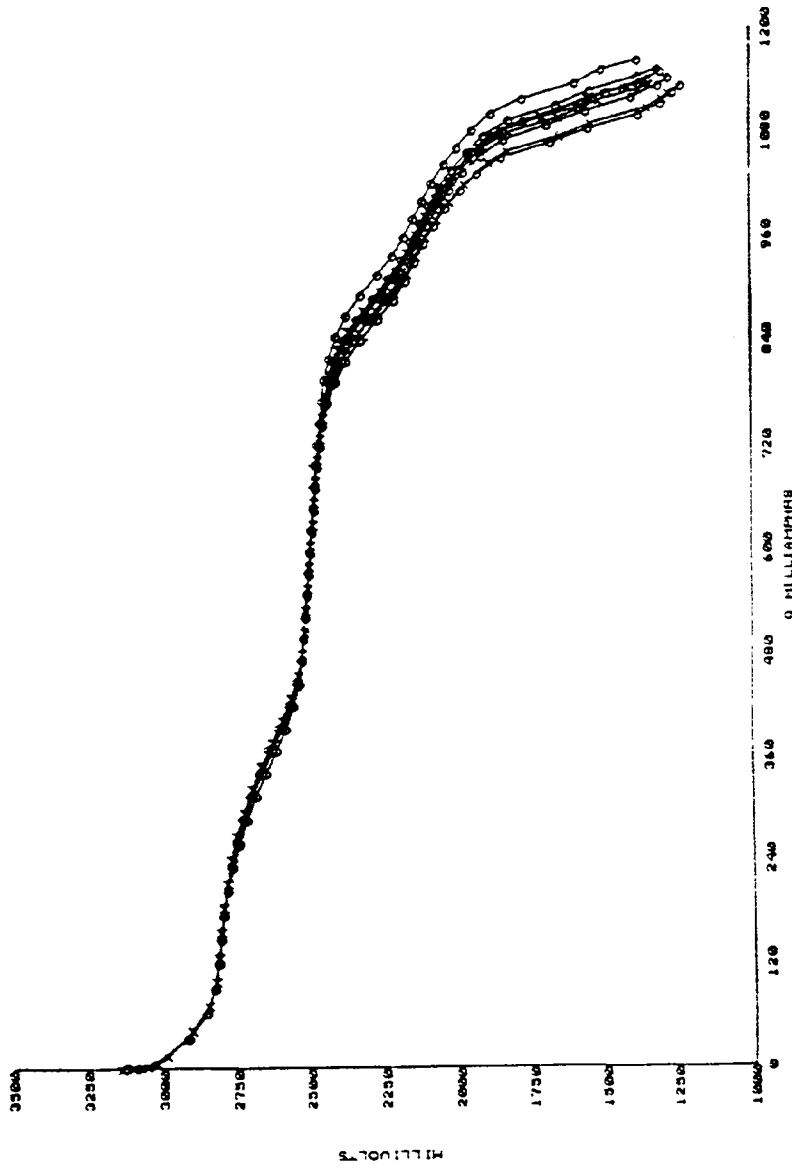

Fig. 30

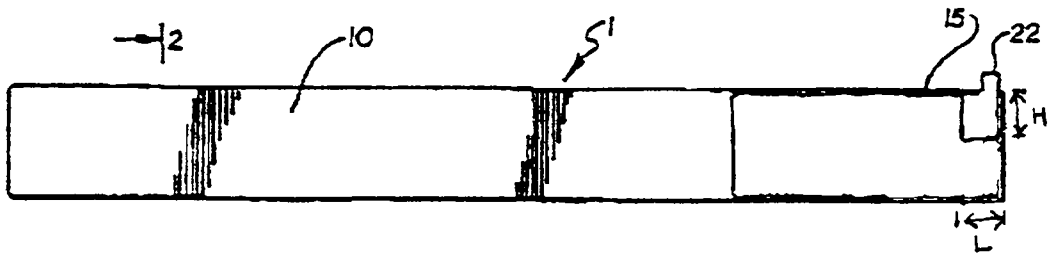

Fig 31

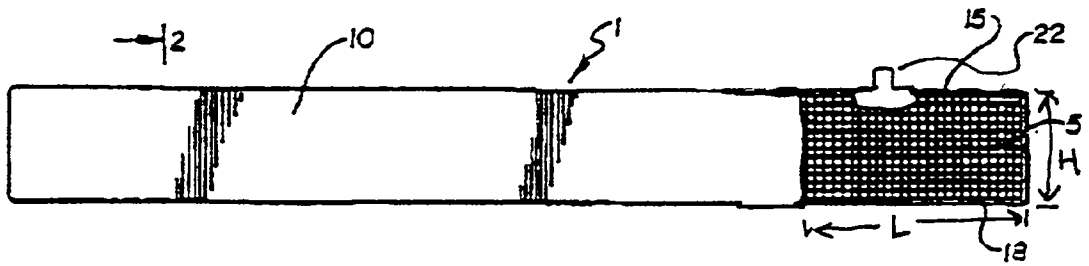

Fig 32

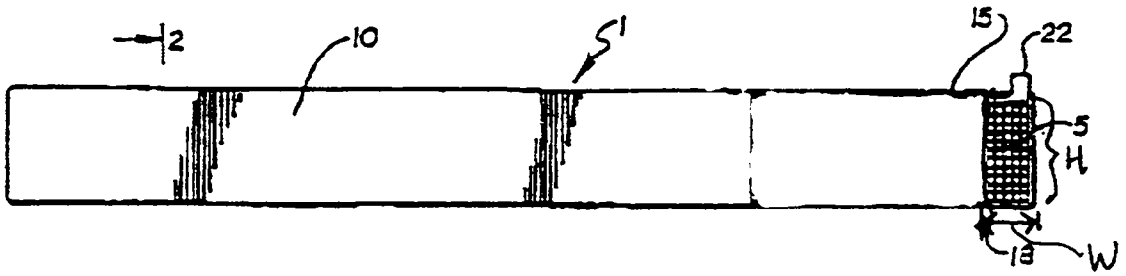

Fig. 33

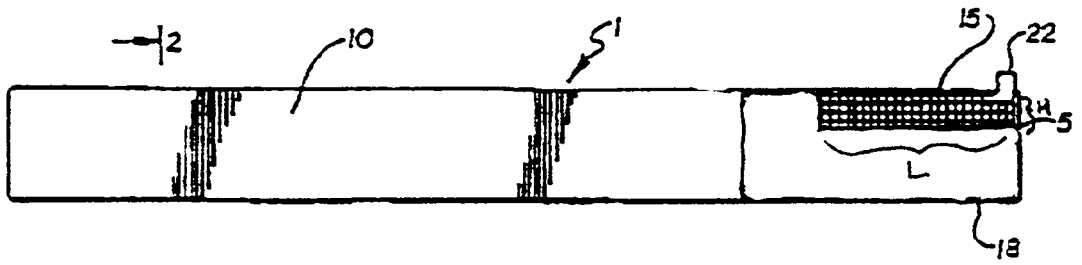

Fig. 34

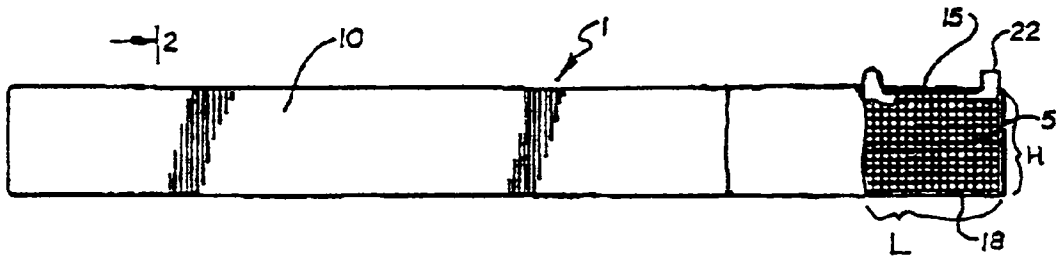

Fig. 35

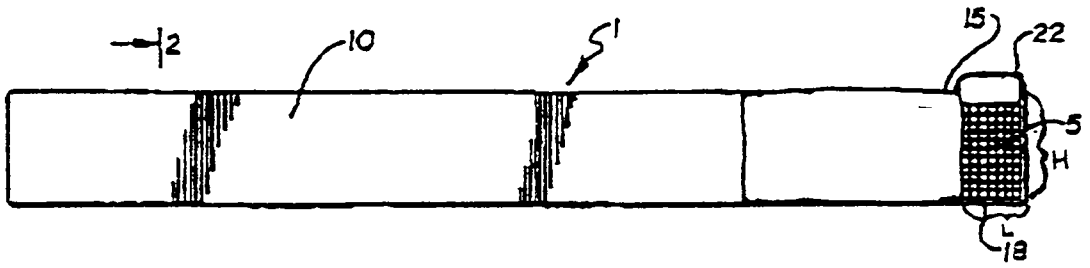

Fig. 36

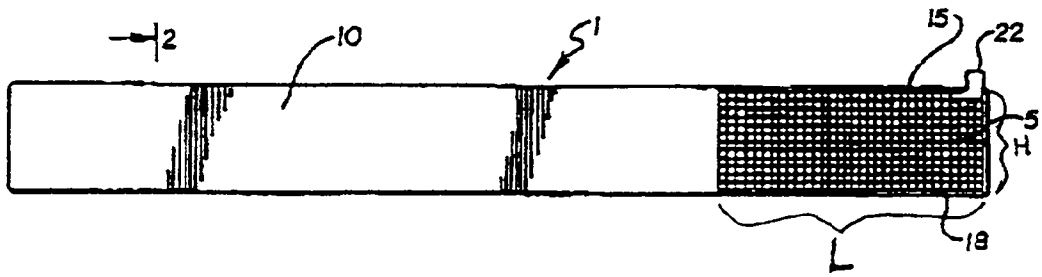

Fig. 37

CURRENT COLLECTOR FOR LITHIUM ELECTRODE

CROSS-REFERENCE TO RELATED APPLICATION

[0001] This application claims priority and other benefits from U.S. Provisional Patent Appln. Ser. No. 60/072,223 for "Spirally Wound High Rate Electrochemical Cell" to Howard et al, and hereby incorporates by reference herein in its entirety such application. This application is also a continuation-in-part of U.S. Patent Appln. Ser. No. 08/430,532 to Howard et al. for "High Reliability Electrochemical Cell and Electrode Assembly therefor" filed Apr. 27, 1995, which is a divisional application of U.S. Patent Appln. Ser. No. 08/155,410 to Howard et al. for "High Reliability Electrochemical Cell and Electrode Assembly therefor" filed Nov. 19, 1993.

FIELD OF THE INVENTION

[0002] This invention relates to electrochemical cells having a lithium anode, and more particularly to primary or secondary electrochemical cells having a lithium anode and corresponding current collector adapted for high reliability and high rates of current discharge.

BACKGROUND OF THE INVENTION

[0003] This invention relates to electrochemical cells having a lithium anode, and more particularly to primary or secondary electrochemical cells having a lithium anode and corresponding current collector adapted for high reliability and high rates of current discharge.

[0004] Implantable cardiac defibrillators are used to treat patients suffering from ventricular fibrillation, a chaotic heart rhythm that can quickly result in death if not corrected. In operation, the defibrillator device continuously monitors the electrical activity of the heart of the patient, detects ventricular fibrillation, and in response to that detection, delivers appropriate shocks to restore a normal heart rhythm. Shocks as large as 30-40 joules may be needed. Shocks are delivered from capacitors capable of providing that energy to the patient in a fraction of a second. In order to provide timely therapy to the patient after the detection of ventricular fibrillation, it is necessary to charge the capacitors with the required amount of energy in only a few seconds. Thus, the power source must have a high rate capability to provide the necessary charge to the capacitors, it must also possess low self-discharge in order to have a useful life of many months, and it must be highly reliable to provide an urgently needed therapy whenever necessary. In addition, since cardiac defibrillators are implanted, the battery must be able to supply energy from a minimum packaged volume.

[0005] One battery suitable for defibrillator use is disclosed in U.S. Pat. No. 4,830,940 to Keister et al, which patent is incorporated herein by reference. As disclosed therein, the anode material of the battery is lithium and the reactive cathode material is silver vanadium oxide. The anode is constructed in a serpentine-like fashion with cathode plates inserted between each of the convolutions thereof on both sides thereof. The electrolyte for a lithium battery or cell is a liquid organic type which comprises a lithium salt and an organic solvent. Both the anode and the cathode plates are encapsulated in an electrically insulative separator

material. However, a disadvantage such a battery design is that the serpentine anode is not efficiently used since anode material at the bends is not faced by cathode material and is therefore not fully utilized. An improvement which addresses this problem is disclosed in U.S. Pat. No. 5,147,737 to Post et al., in which the active material on the serpentine-type electrode is positioned so that the sections of the serpentine-like structure which do not face cathode plates do not contain anode active material. However, the serpentine bends of the anode are still present to the detriment of volumetric efficiency. Additional problems with these battery designs include the number of piece parts and connections required to make the battery which can affect both the manufacturability and the reliability of the battery; and the difficulty of achieving good current distribution and utilization of reactive material due to the unmatched configurations of the anode and cathode.

[0006] Conventional lithium batteries can also employ an electrode body in which anode and cathode elements are combined in spiral wound form. A strip sheet of lithium or lithium alloy comprises the anode, a cathode material supported on a charge collecting metal screen comprises the cathode, and a sheet of non-woven material separates the anode and cathode elements. These elements are combined and wound to form a spiral. Typically, the battery configuration for such a wound electrode would be cylindrical. For example, such configurations may be found in U.S. Pat. Nos. 3,373,060; 3,395,043; 3,734,778; 4,000,351; 4,184,012; 4,332,867; 4,333,994; 4,539,271; 4,550,064; 4,663,247; 4,668,320; 4,709,472; 4,863,815; 5,008,165; 5,017,442, and 5,053,297. Unlike the battery of the '940 patent, the anode material need not be mated to cathode material. Such designs therefore have the potential for an improved match between the cathode and anode components and improved uniformity of anode and cathode utilization during discharge. Cylindrical cells, however, typically cannot achieve the same space utilization inside the case of an implantable defibrillator as a cell of prismatic shape.

[0007] It has also been known to adapt wound electrodes to a prismatic case configuration by departing from a true spiral winding. For example, U.S. Pat. No. 2,928,888 discloses in FIGS. 5a and 5b therein an oblong electrode assembly wound on an elongated mandrel for use in a rectangular case. Also, for example, U.S. Pat. No. 4,051,304 discloses in FIG. 2 therein another oblong wound electrode assembly for use in a rectangular case. However, those patents do not indicate that such structures could be advantageously used for a high current rate capability lithium battery or that they provide a uniform utilization of reactive anode and cathode material during discharge.

SUMMARY OF THE INVENTION

[0008] The present invention has certain objects. That is, the present invention provides solutions to at least some of the problems existing in the prior art respecting high reliability electrochemical cells for implantable medical device applications. It is therefore an object of the present invention to provide a high current rate capability lithium battery having a coiled electrode suitable for use in a prismatic case. It is an object of the present invention to provide a high current rate capability lithium battery which provides uniform utilization of cathode and anode materials during discharge. It is a further object of the present invention to

provide a high current rate capability lithium battery for use in implantable cardiac defibrillators which employs a reduced number of piece parts and welds respecting prior art devices.

[0009] It is an additional object of the present invention to provide an anode assembly which accommodates swelling of the cathode without having localized areas of high force or pressure existing between the anode current collector and the cathode. Such high forces or pressure may lead to undesired compression of electrode material or even puncture of the separator. The anode current collector of the present invention permits an increased degree or amount of cathode expansion to occur than do prior art designs without undesired electrode material compression or separator puncture occurring. This is an important advantage of the present invention, as an increased ability to accommodate cathode swelling assumes becomes ever more important as cathodes increase in thickness and as the bending radii of anode and/or cathode assemblies decrease.

[0010] It is another object of the present invention to provide an anode assembly wherein the probability of lithium isolation occurring during cell discharge is minimized. Such isolation may be caused by misaligned electrodes having localized Faradically unbalanced portions. Faradically unbalanced electrode portions are known to occur in prior art lithium cells where the anode current collector is a single tab pressed onto one end of a strip of lithium metal. The anode current collector of the present invention provides a solution to the problem presented by Faradically unbalanced electrode portions.

[0011] It is another object of the present invention to provide an anode current collector having redundant welds for connecting the anode current collector to a lead, case and/or terminal.

[0012] It is still another object of the present invention to increase the reliability and performance predictability of electrochemical cells of the present invention.

[0013] It is a further object of the present invention to provide a high-reliability electrochemical cell for implantable medical device applications that may be manufactured at lower cost owing to higher energy density, fewer parts, fewer materials and easier assembly.

[0014] These and other objects, features and advantages are provided by the electrochemical cell, electrode assembly and anode current collector of the present invention. We have discovered an electrode assembly and corresponding anode current collector for an electrochemical cell, where the assembly most preferably comprises an alkali metal anode and a cathode assembly wound together in a unidirectional winding having substantially straight sides such that the winding will fit into a prismatic cell, and where the anode current collector has a length and/or height less than that corresponding to at least one of the length or height of an elongated alkali metal strip included in the anode or the length or height of the cathode current collector.

[0015] The anode assembly preferably includes an elongated strip of alkali metal having a first portion with a first uniform thickness of alkali metal and preferably a second portion with a second, lesser uniform thickness of alkali metal and at least one connector tab in electrical contact with the alkali metal on an edge of the anode.

[0016] In a preferred embodiment of the present invention, at least corresponding adjacent ends of the first and second portions of alkali metal are disposed on either side of, and pressed upon, a metal or alloy anode current collector, where the anode current collector has a length less than those corresponding to the first and second portions of alkali metal. The anode current collector may range in length anywhere between the full lengths corresponding to the first and second alkali metal portions and a length substantially shorter than the full length of the alkali metal portions yet longer than the length associated with the one anode current collecting tab only.

BRIEF DESCRIPTION OF THE DRAWINGS

[0017] FIG. 1A shows a side view of an anode component employed in the present invention.

[0018] FIG. 1B shows a side view of an anode current collector 5 of the anode component of FIG. 1A.

[0019] FIG. 2 shows a cross sectional view of a first portion of the anode of FIG. 1A.

[0020] FIG. 3 shows a cross sectional view of a second portion of the anode of FIG. 1A.

[0021] FIG. 3A shows a detailed view of the electrode tab of the anode of FIG. 1A.

[0022] FIG. 4 shows a partially cut-away side view of a combined anode and separator employed in the present invention.

[0023] FIG. 5 shows a cross sectional view of the anode and separator of FIG. 4.

[0024] FIG. 6 shows a partially cut-away side view of a cathode assembly employed in the present invention.

[0025] FIG. 7 shows a cross sectional view of the cathode assembly of FIG. 6.

[0026] FIG. 8 shows a partially cut-away side view of a combined cathode assembly and separator employed in the present invention.

[0027] FIG. 9 shows a cross sectional view of the combined cathode assembly and separator of FIG. 8.

[0028] FIG. 10 shows a top view of a mandrel, cathode assembly and anode assembly of the present invention ready to be wound.

[0029] FIG. 11 shows a top view of the end portion of the mandrel, cathode assembly and anode assembly of FIG. 10 showing the direction of the bend for the anode about the cathode and mandrel.

[0030] FIG. 12 shows a top view of the end portion of the mandrel, cathode assembly and anode assembly of FIG. 11 showing the use of additional separator material at the anode bend.

[0031] FIG. 13 shows a top view of the end portion of the mandrel, cathode assembly and anode assembly showing the completed bend from FIG. 11.

[0032] FIG. 14 shows a perspective view of a completed electrode assembly according to the present invention.

[0033] FIG. 15 shows a top view of the windings of an electrode assembly of the present invention, where separator

material between the winding elements is not shown, and the position of the mandrel in the windings prior to its removal.

[0034] FIG. 16 shows an exploded perspective view of the insertion of an electrode assembly of the present invention into a battery case with insulator materials.

[0035] FIG. 17 shows an exploded perspective view of application of an insulator and case top to the case and electrode assembly of FIG. 16.

[0036] FIG. 18 shows a partial cut-away perspective view of a completed battery of the present invention and the connection of the tabs of an electrode with case elements.

[0037] FIG. 19 shows a partial cut-away perspective view of isolation components for the battery of the present invention.

[0038] FIG. 20 shows a perspective view of an alternative embodiment of isolation components for the battery of the present invention.

[0039] FIG. 21 shows a top view of the end portion of the mandrel, cathode assembly and anode assembly showing the direction of the bend for the cathode about the anode and mandrel.

[0040] FIG. 22 shows a top view of the windings of the electrode assembly of FIG. 21, where the separator material between the winding elements is not shown, after the winding step has been completed, and the position of the mandrel in the windings prior to its removal;

[0041] FIG. 23 shows a full-length anode current collector 5;

[0042] FIG. 24A shows one embodiment of a shortened anode current collector 5 of the present invention having two non-adjacent connector tabs 20;

[0043] FIG. 24B shows a detailed view of the lower left-hand portion of anode current collector 5 shown in FIG. 24A;

[0044] FIG. 24C shows a detailed view of the lower right-hand portion of anode current collector 5 shown in FIG. 24A;

[0045] FIG. 25 shows anode assembly 1 made using current collector 5 of FIG. 24;

[0046] FIG. 26 shows another embodiment of a shortened anode current collector 5 of the present invention having two adjacent connector tabs 20 and 22;

[0047] FIG. 27 shows another embodiment of a shortened anode current collector 5 of the present invention having one connector tab 20;

[0048] FIG. 28 shows yet another embodiment of a shortened anode current collector 5 of the present invention having a length greater than the anode current collectors shown in FIGS. 24, 26 and 27;

[0049] FIG. 29 shows current-voltage discharge profiles obtained during the burn-in of test cells having full length and shortened anode current collectors;

[0050] FIG. 30 shows current-voltage discharge profiles for test cells having full length and shortened anode current collectors, and

[0051] FIGS. 31 through 37 show various embodiments of the anode current collector of the present invention.

DETAILED DESCRIPTION OF THE INVENTION

[0052] As used in the specification and claims hereof, the following terms have the following meanings. The term "tab" means a metallic member generally but not necessarily having four edges and forming a substantially rectangular shape, the tab or member being attached to at least a portion of a current collector, the tab extending or protruding out of or away from an anode body for mechanical or electrical connection to a wire, feedthrough or external electrical circuit. The term "shortened anode current collector" means a current collector having a tab attached to or forming a part of the current collector, the current collector not extending either the full length of a strip- or otherwise-shaped anode body or the full height of a strip- or otherwise-shaped anode body, or any combination or permutation of lengths or heights thereof.

[0053] Referring now to the drawings, FIGS. 1A through 6 show the anode portion of the electrode assembly. In FIG. 1A, elongated anode assembly 1 is shown including current collector 5 having a first layer of alkali metal 10 on one side and a second layer of alkali metal 15 on the other side. Alkali metal layers 10 and 15 are most preferably formed from a lithium metal or alloy pressed onto the screen current collector 5. FIG. 1B shows a side view of shortened length current collector 5 of the anode assembly of FIG. 1, where tabs 20 and 22 project upwardly therefrom.

[0054] In one embodiment of the present invention, anode current collector 5 in FIG. 1B is characterized in having length L and height H, either one or both of which may be less than the corresponding lengths or heights of the alkali metal strips 10 or 15 pressed or disposed thereon to form an anode electrode assembly. For example, length L or height H of anode current collector 5 may be about 90%, about 80%, about 70%, about 60%, about 50%, about 40%, about 30%, about 20%, about 15%, about 10% or about 5% of the lengths or heights corresponding to alkali metal strips 10 or 15 pressed or disposed on anode current collector 5.

[0055] In another embodiment of the present invention, anode current collector 5 of FIG. 1B is characterized in having length L and height H, either one or both of which may be less than the corresponding length or height of cathode current collector 55. For example, length L or height H of anode current collector 5 may be about 90%, about 80%, about 70%, about 60%, about 50%, about 40%, about 30%, about 20%, about 15%, about 10% or about 5% of the length L or height H corresponding to cathode current collector 55.

[0056] In still another embodiment of the present invention, anode current collector 5 is characterized in having length L and height H, either one or both of which may be less than the corresponding length L or height H of cathode current collector 55 and/or less than the lengths or heights corresponding to alkali metal strips 10 or 15 pressed or disposed on anode current collector 5. It will now be seen that a virtually infinite number of various combinations of respective heights and lengths of anode current collector 5, cathode current collector 55 and alkali metal strips 10 and 15 fall within the scope of the present invention.

[0057] FIG. 2 shows a cross-sectional view of the sandwich structure of anode assembly 1 with current collector 5 interposed between first and second layers of alkali metal 10 and 15, respectively. FIG. 3 shows in cross section that anode assembly 1 has at one end 18 alkali metal layer 15 only on one side of current collector 5. A bare portion of current collector 5 most preferably forms the outer wrap of the wound electrode assembly since no active material is required for such surface.

[0058] Current collector 5 is an electrically-conductive metal that is corrosion-resistant when associated with the alkali metal 10, 15, and is most preferably formed of nickel, titanium, copper, an alloy thereof, or any other transition metal or metal alloy that does not readily form an alloy with lithium such as iron, stainless steel and metals of or alloys formed from Group IB of the Periodic Table. First and second connector tabs 20, 22 most preferably project from the upper or lower edge of current collector 5, although a single connector tab may also be used since the conductivity of lithium metal on a current collector formed of suitable metal or alloy is capable of providing adequate current distribution at high discharge rates if the current collector has sufficient conductive cross sectional area for its length. Additional connector tabs may also be added if improved reliability of connections is desired.

[0059] Connector tabs 20 and 22 may also be incorporated into current collector 5 when formed as shown in FIG. 3A. The current collector 5 is preferably made by an etching process which provides smooth edges on the current collector 5 and thereby eliminates stray metal pieces which might otherwise poke through the separator material and cause shorting of the battery. An alternative to anode assembly 1 depicted in FIGS. 1 through 5 is to dispense with the current collector 5 in favor of an anode which is made up almost entirely of an alkali metal or alkali metal alloy. In such a configuration, the alkali metal would be formed in a thicker cross-section at one end than at another and the connector tabs would be connected directly to the alkali metal.

[0060] FIGS. 4 and 5 show anode assembly 1 covered by separator 25. Separator 25 forms a pocket around the anode assembly 1 since it folds over at the top edge 27 and conforms to the anode assembly 1 until it reaches the bottom edge 29 where it is joined to itself at a seal 30. Slits (not shown) can be cut in the separator 25 to allow the connector tabs 20, 22 to project through the separator 25. The material used in the separator 25 can be a commercially available microporous polyolefin (i.e. polyethylene or polypropylene) separator material such as CELGARD 4560 (a microporous/nonwoven laminate material made by Hoechst Celanese). Preferably, the nonwoven side of separator 25 is pressed into the surface of alkali metal layers 10 and 15 of the anode assembly 1 such that the alkali metal deforms into intimate contact with the separator 25 and bonds to the separator 25.

[0061] This deformation bonding can be accomplished by pressing the nonwoven side of separator 25 onto alkali metal layers 10 and 15 in an hydraulic press, and may further be accomplished in the same pressing operation in which alkali metal layers 10 and 15 are pressed onto the current collector 5 as described above. In preparation for the pressing operation, alkali metal layers 10 and 15 are cut to size from appropriate sheets of anode material, weighed, and then

placed on either side of the current collector 5 in a die. The die and anode components 5, 10 and 15 are then placed in a rolling fixture which presses alkali metal layers 10 and 15 onto the current collector at a pressure sufficient to hold them in place. The separator 25 is then placed around the anode assembly 1 and is pressed onto alkali metal layers 10 and 15 on anode assembly 1 by an hydraulic press at a pressure such as 800 psi that deforms the anode metal into intimate contact with the separator. Seal 30 for separator 25 may be a heat seal made by conventional heat sealing equipment.

[0062] FIGS. 6 through 9 show elongated cathode assembly 50, which includes current collector 55 onto which layers 60 and 65 of a cathode material are pressed. Most preferably, cathode assembly 50 has essentially the same width as the anode assembly 1. The cathode material includes a solid reactive cathode ingredient such as manganese dioxide, V_6O_{13} , silver vanadium oxide, or CF_x , or mixtures or combinations thereof, and dry mixtures including such materials together with such binders and conductivity enhancers as may be desirable.

[0063] Preferably, the silver vanadium oxide employed is that disclosed in U.S. Pat. No. 5,221,453 to Crespi, which is a "combination silver vanadium oxide" or "SVO". For example, in a battery employing silver vanadium oxide as a reactive cathode ingredient, about 5% PTFE may be added as a binder along with about 2% carbon black and 2% graphite as conductivity enhancers. The particulate ingredients can be mixed together, dried to a desired moisture content, placed in a uniform layer over the current collector 55 and then dry pressed in a high pressure press to form each of the cathode material layers 60 and 65. Alternatively, wet processes known in the art could also be used in which a wet mix of cathode material is deposited on the current collector 55 and then dried and rolled to form each of the cathode material layers 60 and 65.

[0064] Connector tabs 70 and 72 project from the edge of the current collector 55 in substantially the same manner as in anode assembly 1 described above. Current collector 55 is a conductive metal that is corrosion-resistant when associated with the cathode material, preferably titanium, stainless steel or an alloy of titanium.

[0065] Separator 75 most preferably forms a pocket around cathode assembly 50 in the same manner as that for anode assembly 1 above, and is provided with seal 80. The material used to form separator 75 may be the same commercially available microporous polyolefin (i.e. polyethylene or polypropylene) separator material most preferably employed in anode assembly 1. Seal 80 may be formed using heat seal means. It is preferred that separator 75 for cathode assembly 50 be made slightly larger than cathode assembly 50 to allow for swelling of the cathode layers 60 and 65 as the battery is discharged and to keep the battery from splitting as it is discharged. This is in contrast to separator 25 for the anode assembly 1, which most preferably tightly fits around the circumference of anode assembly 1.

[0066] FIGS. 10 through 13 indicate how the winding process may be initiated. FIG. 10 shows how anode assembly 1 is most preferably aligned with cathode assembly 50 and mandrel 100 to commence the winding operation. Separators 25 and 75 for those components are in place

around anode assembly **1** and cathode assembly **50**, respectively, during the winding operation although they are not shown in **FIGS. 10 through 13**.

[**0067**] It should be noted that anode assembly **1** is longer than cathode assembly **50** and has been positioned such that end **1a** overlaps corresponding end **50a** of cathode assembly **50**. End **50a** of cathode assembly **50** has been positioned slightly behind edge **100a** of mandrel **100**. Anode assembly **1** has also been placed against cathode assembly **50** such that alkali metal layer **15** is pressed against cathode material layer **60** at end **18** of anode assembly **1** to ensure the outer winding of the electrode assembly has alkali metal layer **15** facing cathode material **60** and bare current collector **5** at end **18** faces outwardly.

[**0068**] As shown in **FIGS. 11 and 13**, the winding process is commenced by bending end **1a** of anode assembly **1** onto mandrel **100**. As shown, bend **105** also bends anode assembly **1** around the end of the cathode assembly. A minor to this bending procedure alternative (not shown in the Figures) that may find particularly efficacious use when making bend **105** by hand is to first bend anode assembly **1** over mandrel **100** in the absence of the cathode assembly **50** (but including a spacer of equivalent thickness to the cathode assembly **50** to make the proper bend radius on the anode assembly **1**), and then remove the spacer and slip cathode assembly **50** between mandrel **100** and anode assembly **1**.

[**0069**] It may be desirable to place additional separator material between anode assembly **1** and cathode assembly **50**, and between anode assembly **1** and mandrel **100**, to provide smoother bends. This may be accomplished as shown in **FIG. 12**, where additional separator material **110** has been placed over the anode assembly **1** and between anode assembly **1** and cathode assembly **50** at the point where bend **105** is to be made. A most convenient method for adding additional separator material **110** is to merely make separator **25** longer and extend separator **25** for anode assembly **1** beyond the length of anode assembly **1** at appropriate end **1a**, and to simply fold separator **25** back along anode assembly **1**, thereby providing a triple thickness of separator material at the point of bend **105**.

[**0070**] The winding then most preferably proceeds by winding combined anode assembly **1** and cathode assembly **50** around mandrel **100** unidirectionally until the electrode assembly is completed. It is essential that the winding process be carried out by a method which will result in consistent winding tension. Uneven winding tension may cause higher and lower resistance paths during discharge and thereby produce uneven current distribution. Uneven winding tension may also result in the location of the connector tabs **20, 22, 70** and **72** being undesirable altered or moved in the final winding which may make establishing the necessary subsequent mechanical and electrical connections difficult. Even winding tension may be realized through careful hand winding or appropriate machine winding. Machine winding is preferred because it can produce greater battery-to-battery winding tension uniformity.

[**0071**] **FIG. 14** shows completed electrode assembly **120** with connector tabs **20, 22, 70** and **72** projecting from electrode assembly **120**. Most preferably, connector tabs **20** and **22** are disposed on one side of electrode assembly **120**, while connector tabs **70** and **72** are spaced apart from anode connector tabs **20** and **22** on the opposite side of the

electrode assembly as shown. Such a tab construction helps avoid inadvertent shorts in the completed battery. Additionally, it is preferred that connector tabs **20, 22, 70** and **72** be located such that they are positioned close to their intended connection point with the feedthrough or case and with no overlap between cathode tabs or anode tabs to facilitate the making of the individual welded connections.

[**0072**] **FIG. 15** shows the final arrangement of the windings in one embodiment of electrode assembly **120** together with mandrel **100**; note that separators **25** and **75** and current collectors **5** and **55** are not shown. Consistent winding of anode assembly **1** and cathode assembly **50** results in electrode assembly **120** in which mandrel **100** determines substantially the length of the straight sides of electrode assembly **120** and in which final anode layer **125** has alkali metal layer **15** only facing cathode material **60**. As described above, and depending on the particular embodiment of the present invention selected, current collector **5** may be eliminated altogether, substantially eliminated, shortened, or at least partially eliminated in the battery. Thus, for example, final anode layer **125** may be formed simply of anode material having half the thickness of the remainder of the anode.

[**0073**] Removal of the mandrel **100** brings first end **1a** of anode assembly **1** into contact on both sides with cathode assembly **50** and completes electrode assembly **120**. It will be appreciated that in order to provide close proximity between anode assembly **1** and cathode assembly **50** at the start of the winding that mandrel **100** is most preferably very thin. For example, a stainless steel mandrel about 0.010 inch thick may be used, although thicker mandrels may be employed if additional stiffness is desired or required.

[**0074**] As will be appreciated by those skilled in the art, the number of windings chosen for the battery will be determined by the required rate of discharge and the required capacity of the battery. Increasing the number of windings will provide an increased ability to discharge at a high rate but will tend to reduce the capacity per unit volume for the battery.

[**0075**] Assembly of electrode assembly **120** into a completed battery is shown in **FIGS. 16 through 18**. In **FIG. 16**, coil insulator **200** is placed onto electrode assembly **120**. Coil insulator **200** includes notch **202** for accommodating anode connector tab **22** and slits **204, 206** and **208** for accommodating anode connector tab **20** and cathode connector tabs **70** and **72**, respectively. Electrode assembly **120** is also inserted into insulative case liner **210**. Case liner **210** preferably extends at its top edge above the edge of the electrode assembly **120** to provide an overlap with other insulative elements. If so, it may include notch **211** on one side in order to allow easy connection of anode connector tabs **20** and **22** to case **220**. Coil insulator **200** and case liner **210** are most preferably formed from a polyolefin polymer or a fluoropolymer such as ETFE or ECTFE. Electrode assembly **120** and case liner **210** are then inserted into prismatic case **220**, which is most preferably formed of stainless steel.

[**0076**] In **FIG. 17**, case cover **230** and pin insulator **240** are shown along with electrode assembly **120** and prismatic case **220**. Case cover **230** most preferably includes glassed-in feedthrough **232** and feedthrough pin **233** extending through an aperture in case cover **230** having bend **234**.

Bend **234** places feedthrough **232** in alignment with cathode connector tabs **70** and **72**. Case cover **230** also most preferably has fill port **236**. Case cover **230** is most preferably formed from stainless steel. Feedthrough pin **233** is most preferably formed from niobium or molybdenum. Pin insulator **240** has aperture **242** leading into raised portion **244** for receiving feedthrough pin **233** and insulating feedthrough pin **233** from contact with case cover **230**.

[0077] In combination with one side of coil insulator **200** (which is disposed immediately below pin insulator **240**), the raised portion forms a chamber which isolates the cathode connections. Additional insulation in the form of tubing or a coating (not shown) may also be included on feedthrough pin **233** or feedthrough **232** at locations which are not welded to further insulate feedthrough pin **233** and feedthrough **232**. An additional cover insulator (not shown) may also be applied to the underside of case cover **230** to provide additional insulation for case cover **230**. Feedthrough pin **233** is most preferably welded to cathode connector tabs **70** and **72** as shown in FIG. 18. Anode connector tabs **20** and **22** are most preferably bent into an "L" shape as shown in FIG. 18 and welded to the side of case **220** to thereby make metal case **220** one terminal or contact for the battery (i.e. a case negative design). Feedthrough pin **233** is then inserted through a split (not shown) in the pin insulator **240** until it projects through aperture **242** of pin insulator **240**. Electrode assembly **120** may be located outside case **220** during some of the welding and bending operations. Naturally, all electrode welding operations should take place in an inert gas atmosphere. Case cover **230** is then welded to case **220** to seal electrode assembly **120** in the case.

[0078] FIG. 19 shows isolation components for the battery in greater detail. Cover insulator **245** is adapted to fit under case cover **230** with aperture **246** to accommodate feedthrough **232** and feedthrough pin **233**. Cut-away portion **247** accommodates fill port **236**. Cover insulator **245** is applied to the underside of case cover **230**. Feedthrough insulator **250** then slides over feedthrough pin **233** and over feedthrough **232** into contact with cover insulator **245**. Once feedthrough insulator **250** is in place, tubular insulator **255** is slipped over feedthrough pin **233** until it contacts the glass of feedthrough **232**. Feedthrough pin **233** is then bent into its desired configuration for connection with cathode connector tabs **70** and **72** (as shown in FIG. 17).

[0079] Pin insulator **240** is shown with split **241** extending from the edge of pin insulator **240** to aperture **242**. Pin insulator **240** has aperture **242** leading into raised portion or recess **244** for receiving feedthrough pin **233** and tubular insulator **255** over the feedthrough pin and insulating feedthrough pin **233** from contact with the case cover **230** at the point where feedthrough pin **233** is welded to cathode connector tabs **70** and **72**. Split **241** allows pin insulator **240** to be placed on feedthrough pin **233** after feedthrough pin **233** has been welded to cathode tabs **70** and **72**. Tubular insulator **255** therefore extends through aperture **242**, thereby preventing any discontinuity in the isolation of the cathode connector tabs **70** and **72** and feedthrough pin **233** from elements at anode potential.

[0080] Coil insulator **202a** is shown with a notch **202** to accommodate anode connector tab **22** and slits **204** and **206** to accommodate anode connector tab **20** and cathode con-

necting tab **70**, respectively. Notch **208a** is also provided to accommodate cathode connector tab **72** in place of slit **208** shown in FIG. 16. Electrode assembly **120** is also inserted into insulative case liner **210**. All case isolation components, including cover insulator **245**, feedthrough insulator **250**, tubular insulator **255**, pin insulator **240**, coil insulator **202a** and case liner **210**, are most preferably molded or extruded self-supporting polymeric parts made from, for example, polyolefin polymers or fluoropolymers such as E/TFE or ECTFE. The result of such an insulator configuration is cathode connections that are thoroughly isolated electrically from portions of the battery at anode potential and a feedthrough connection that is thoroughly isolated from stray particles of cathode or anode material that may form as a result of battery discharge.

[0081] It will be appreciated that additional improvements to the foregoing insulator configuration may be achieved by improving the fit between insulative components to provide better isolation of anode and cathode elements. For example, aperture **242**, pin insulator **240** and tubular insulator **255** may be sized to be tightly fitting components, or feedthrough pin **233** may be fitted with corresponding mating insulator parts for providing a snap fit to thereby reduce, obviate or eliminate migration of stray battery materials or particles through aperture **242**.

[0082] Alternative configurations of the foregoing type may be similar to that shown in FIG. 20, where a perspective view of an alternative embodiment of isolation components for the battery of the present invention is shown. In FIG. 20, snap fit isolation system **260** is shown which reduces the number of isolation components in the battery. Snap fit isolation system **260** may comprise two principal components: top component **265** and bottom component **270**, where components **265** and **270** are most preferably formed by injection molding means from an electrically insulative plastic or polymeric material. Components **265** and **270** may be employed to replace components **202a** and **240**, and optionally component **245** of FIG. 19.

[0083] Bottom component **270** most preferably includes apertures **272a** and **272b** for accommodating two cathode connector tabs and notch **274** (which, in turn, may accommodate an anode connector tab and also provide a passageway from fill port **236** into the remainder of the battery case to facilitate filling of the battery with electrolyte). Hooks **276a** and **276b** are adapted to mate with top component **265** to form a secure snap fit between top component **265** and bottom component **270**.

[0084] Many alternative structures for forming a secure snap fit between components **265** and **270** are contemplated in the present invention, some of which are well known. Additionally, one of hooks **276a** and **276b** may be omitted in favor of a molded hinge for joining one edge of each of components **265** and **270** to one another. Top component **265** may include first aperture **267** for accommodating feedthrough pin **233** and second aperture **268** aligned with fill port **236** to allow electrolyte to be introduced in the battery through fill port **236**.

[0085] Top component **265** may also include partition wall **269** which, when top and bottom components **265** and **270** are joined together, separate cathode connections, feedthrough pin **233** from fill port **236**, an anode connection (only one anode tab is employed to connect the anode with

the case in the embodiment shown in FIG. 20) from cathode connections, feedthrough pin 233 and other battery components. By joining components 265 and 270, a separate compartment is created to house feedthrough pin 233 and its connections with the cathode tabs.

[0086] Alternative embodiments of the present invention in which the battery is a case positive design or case neutral design can readily be constructed in like manner. For a case positive design, cathode connector tabs 70 and 72 may be rearranged for welding to case 220 while anode connector tabs 20 and 22 may be rearranged for welding to feedthrough pin 233. In a case neutral design, an additional feedthrough may be supplied that is connected to anode connector tabs 20 and/or 22.

[0087] As shown in FIGS. 21 and 22, yet another embodiment of the present invention may be constructed readily by exchanging the relative positions of the cathode and anode materials. FIG. 21 shows a top view of the end portion of the mandrel, cathode assembly and anode assembly, and shows the direction of the bend for the cathode about the anode and mandrel. FIG. 22 shows a top view of the windings of the electrode assembly of FIG. 21. In FIG. 22, the separator material between the winding elements is not shown, and the various battery elements are displayed after the winding step has been completed and with the mandrel positioned in the windings prior to its removal.

[0088] In such an alternative embodiment of the present invention, the electrode assembly configuration is reversed so that the cathode assembly is made longer than the anode assembly. A portion of the current collector only having cathode material on one side forms the outer layer of the winding, and the winding is initiated by bending the cathode assembly over the mandrel. Other embodiments of the present invention described hereinabove, however, are generally preferred due to their superior rate capabilities and greater volumetric efficiencies.

[0089] An appropriate electrolyte solution is introduced through fill port 236 by a vacuum filling process, after which fill port 236 is sealed. The electrolyte solution may be an alkali metal salt in an organic solvent such as a lithium salt (e.g., 1.0 M LiClO₄, LiPF₆ or LiAsF₆) in a 50/50 mixture of propylene carbonate and dimethoxyethane. The sealing process (not shown in the Figures) may include, for example, making a first seal by pressing a plug into the aperture of fill port 236 and making a second seal by welding a cap or disc over fill port 236. As is well known in the art, a material for leak checking hermetic seals may be included between the first and second seals.

[0090] FIG. 23 shows a full-length anode current collector 5. A first group of six spirally wound test cells was built using the full-length anode current collector 5 of FIG. 23 and other cell components and methods disclosed herein. Cells of the first group are referred to as cells 1 through 6 herein.

[0091] FIGS. 24A through 24C show one embodiment of a shortened anode current collector 5 of the present invention having two non-adjacent connector tabs 20. FIG. 24A shows a side view of the entire anode current collector 5, while FIGS. 24B and 24C show details of a preferred grid pattern at two end portions of current collector 5. A second group of seven spirally wound test cells was built using

shortened anode current collector 5 of FIG. 24A. Cells of the second group are referred to as cells 8 through 14 herein. In the second group of cells, corresponding ends of first and second portions of lithium were aligned and then embedded in shortened current collector 5 of FIG. 24A such that shortened current collector 5 was disposed in only that portion of anode assembly 1 forming the outer wrap or outer layer in a spirally wound cell. Anode assembly 1 employed in the second group of test cells is shown in FIG. 25.

[0092] With the exception of the shortened anode current collectors in the second group of test cells, cells of the first and second groups were constructed using identical structures, materials and compositions, including identical CELGARD® 4560 separators, identical silver vanadium oxide cathode compositions, identical lithium anode compositions and identical electrolytes comprising 1 Molar LiAsF₆ in a 50/50 mixture of propylene carbonate and dimethoxyethane. Anode and cathode current collectors in cells of the first and second groups were formed from nickel having a thickness of about 0.0020 inches. Additionally, hand winding methods employed to form the cells of the two groups were identical.

[0093] Further details and specifications concerning the construction and materials employed in forming the test cells of the first and second groups are set forth in Table 1 below, where all dimensions are in inches and all fill weights are in grams.

[0094] Following assembly, cells of the first and second groups were burned in using identical burn-in procedures, where all cells were discharged for 17 hours through a 2.7 kOhm load, followed by a 1.16 Ampere four pulse sequence and open circuit storage for a period of 5.25 days. FIG. 29 shows current-voltage discharge profiles obtained during the burn-in of test cells of the first and second groups having full length and shortened anode current collectors, respectively. Further results concerning burn-in of the test cells are set forth in Table 2 below.

TABLE 1

General Specifications for Test Cells of the First and Second Groups	
<u>Anode</u>	
Length overall	6.20"
Height overall	0.65"
Length current collector for first group	6.08"
Height current collector for first group	0.57"
Length current collector for second group	2.40"
Height current collector for second group	0.57"
Mass lithium*	0.39 g
<u>Cathode</u>	
Length overall	5.00"
Height overall	0.65"
Length current collector	5.00"
Height current collector p	0.65"
Mass	4.30 g
Mix Type	Silver vanadium oxide
Electrolyte Type	1M LiAsF ₆ in a 50/50 mixture of propylene carbonate and dimethoxyethane.
<u>Separator</u>	
Type	Celgard 4560
Configuration Type	Prismatic/Wound electrodes

[0095]

TABLE 2

Burn-In Results for Test Cells of the First and Second Groups					
Cell #	Group	Final 2.7 KΩ Load Voltage	Pre-Pulse OCV (mV)	Min. 1.16 AMP Voltage, 1st Pulse (mV)	Min. 1.16 AMP Voltage, 4th Pulse (mV)
1	1	3098	3236	2187	2264
2	1	3098	3234	2253	2271
3	1	3098	3236	2212	2281
4	1	3099	3236	2171	2249
5	1	3100	3236	2269	2305
6	1	3099	3234	2223	2306
8	2	3099	3231	2226	2256
9	2	3100	3231	2238	2271
10	2	3098	3230	2228	2270
11	2	3096	3228	2265	2310
12	2	3098	3230	2225	2252
13	2	3096	3228	2253	2283
14	2	3097	3230	2230	2278

[0096]

TABLE 3

Delivered Capacity and Cathode Utilization for Test Cells of the First and Second Groups Discharged to 1.4 Volts through a 50 Ohm Load		
Cell	Description	mAH to 1.4 V*
3	First Group - Full	1126
4	Length Anode	1132
5	Current Collectors	1134
6		1104
	MEAN	1124
	STD DEV	14
8	Second Group	1141
9	Shortened Anode	1161
10	Current Collectors	1120
11		1097
12		1134
	MEAN	1131
	STD DEV	24

*CAPACITY EXCLUDES BURN-IN

[0097] Following burn-in, cells 1, 2, 13 and 14 were purposely shorted through a 20 milli-Ohm external load for four hours at an ambient temperature of 37 degrees Celsius to replicate extreme abuse conditions. During the shorting tests, individual cell voltages, current and temperatures were monitored. Cells 13 and 14 containing shortened anode current collectors exhibited higher peak currents. Peak temperatures attained in all cells were approximately equal, but cells having shortened anode current collectors reached their peak temperatures more quickly.

[0098] Cells 1, 2, 13 and 14 were then taken apart and examined. Severe separator damage was noted to have occurred in all shorted cells. Heat generated by shorting fused some separator areas together. All other considerations being equal, shortened anode current collectors cells provided substantially the same performance as that of all having full length anode current collectors.

[0099] Also following burn-in, remaining cells 3-6 and 8-12 were discharged through identical 50 Ohm loads at an ambient temperature of 37 degrees Celsius until an end

discharge voltage of 1.4 Volt was obtained. FIG. 30 shows voltage-current discharge profiles for cells 3-6 and 8-12. Table 4 sets forth the results of the 50 Ohm load 1.4 Volt discharge tests, and the delivered capacity and cathode utilization obtained.

[0100] The discharge profiles of FIG. 30 are stable and reproducible, regardless of the type of anode current collector employed. Variations in voltage appearing towards the ends of the discharge profiles are believed to be due to entirely, or at least principally, to minor variations in the starting amounts of cathode active material employed to build the test cells. FIG. 30 and Table 3 show that the type of anode current collector employed has little if any effect on cell performance when all other cell parameters are held constant (e.g., amounts of anode and cathode active material employed, type of electrolyte, etc.).

[0101] Cells 3-6 and 8-12 were taken apart and examined upon conclusion of the discharge tests. Upon disassembly, cells 3-6 of the first group of cells were all noted to have sustained various types of damage to the separators thereof. More particularly, the separators of cells 3-6 were discovered to have transparencies and splits not attributable to the tear-down procedure. Such transparencies, or thinned portions of the separator, were found to have been caused by expansion of the cathode layer at points where bending radii of the spirally-wound electrodes were most severe (or smallest). It was concluded that pressure exerted by expanding cathodes through the separator and against the full-length anode current collector caused the observed transparencies.

[0102] In contrast, cells 8-14 of the second group of cells displayed no transparencies or thinning of separators at points where bending radii of the spirally-wound electrodes were most severe. Moreover, cell case expansion in cells 8-14 was noticeably less than that observed to occur in cells 1-6.

[0103] It will now become clear that it is an advantage of the shortened anode current collector of the present invention that more active material, either anodic or cathodic, may be included in a cell having the same internal volume and otherwise similar in all respects saving for a full length anode current collector. Conversely, a cell having a shortened anode current collector and the same amount of anode and cathode active material as an otherwise similar cell having a full length anode current collector may be made in accordance with the teachings of the present invention that occupies less overall volume.

[0104] FIG. 25 shows anode assembly 1 made using current collector 5 of FIG. 24. FIG. 26 shows another embodiment of a shortened anode current collector 5 of the present invention having two adjacent connector tabs 20 and 22. FIG. 27 shows another embodiment of a shortened anode current collector 5 of the present invention having one connector tab 20. FIG. 28 shows yet another embodiment of a shortened anode current collector 5 of the present invention having a length greater than the anode current collectors shown in FIGS. 24, 26 and 27. FIGS. 32 through 38 show yet other embodiments of the shortened anode current collector 5 of the present invention.

[0105] In the Figures, all dimensions shown are merely illustrative, and are not intended to limit the scope of the present invention. It is to be understood that other expedients

known to those skilled in the art or disclosed herein, may be employed without departing from the invention or the scope of the appended claims. For example, the present invention is not limited to electrochemical cells having a spirally wound electrode construction. The present invention is also not limited to shortened anode current collectors of constant thickness in spirally wound electrode assemblies per se, but includes within its scope anode current collectors having varying thicknesses, different stiffnesses and different grid patterns. Additionally, the anode current collector of the present invention is not limited to embodiments having connector tabs attached to an edge of a gridded current collector or to a screen-like current collector, but instead includes within its scope anode current collectors forming with the connector tab a single imperforate piece of metal as well as current collectors having holes formed therein by punching, stamping, rolling, chemical etching and other means. The present invention further includes within its scope methods of making and using the current collector described hereinabove.

[0106] In the claims, means-plus-function clauses are intended to cover the structures described herein as performing the recited function and not only structural equivalents but also equivalent structures. Thus, although a nail and a screw may not be structural equivalents in that a nail employs a cylindrical surface to secure wooden parts together, whereas a screw employs a helical surface, in the environment of fastening wooden parts a nail and a screw are equivalent structures.

[0107] All patents listed hereinabove are hereby incorporated by reference into the specification hereof in their respective entireties. As those of ordinary skill in the art will appreciate readily upon reading the Summary of the Invention, Detailed Description of the Preferred Embodiments and Claims set forth herein, at least some of the devices and methods disclosed in those patents may be modified advantageously in accordance with the teachings of the present invention.

I claim:

1. An electrode assembly for an electrochemical cell, comprising:

(a) an anode assembly comprising an elongated strip of alkali metal forming an anode and an anode current collector having at least a first connector tab disposed on a first edge thereof, the strip of elongated alkali metal having a first length and a first height, the anode current collector having a second length and a second height;

(b) a cathode assembly, comprising:

(1) a cathode current collector having disposed on a second edge thereof at least a second connector tab, the cathode current collector having a third length and a third height; and

(2) a cathode material bonded to the current collector, the anode and cathode assemblies forming a unidirectional electrode winding having two substantially straight sides, the assemblies having interposed therebetween at least one separator, the first length of the anode current collector being shorter than the second length of the elongated strip of alkali metal.

2. The electrode assembly of claim 1, wherein the first length is about 90%, about 80%, about 70%, about 60%, about 50%, about 40%, about 30%, about 20%, about 15%, about 10%, or about 5% shorter than the second length.

3. The electrode assembly of claim 1, wherein the anode current collector is formed from a material selected from the group consisting of titanium, nickel, copper and alloys thereof.

4. The electrode assembly of claim 1, wherein the cathode current collector is formed of titanium.

5. The electrode assembly of claim 1, wherein the cathode material comprises a solid reactive material, a binder material and a conductivity enhancer.

6. The electrode assembly of claim 1, wherein the solid reactive material is silver vanadium oxide.

7. The electrode assembly of claim 1, wherein the binder material is PTFE.

8. The electrode assembly of claim 1, wherein the conductivity enhancer is conductive carbon.

9. The electrode assembly of claim 1, wherein the separator covers the anode assembly and provides a seal therearound, the pouch having an opening through which the at least first connector tab projects.

10. An electrode assembly for an electrochemical cell, comprising:

(a) an anode assembly comprising an elongated strip of alkali metal forming an anode and an anode current collector having at least a first connector tab disposed on a first edge thereof, the strip of elongated alkali metal having a first length and a first height, the anode current collector having a second length and a second height;

(b) a cathode assembly, comprising:

(1) a cathode current collector having disposed on a second edge thereof at least a second connector tab, the cathode current collector having a third length and a third height; and

(2) a cathode material bonded to the current collector, the anode and cathode assemblies forming a unidirectional electrode winding having two substantially straight sides, the assemblies having interposed therebetween at least one separator, the first height of the anode current collector being shorter than the second height of the elongated strip of alkali metal.

11. The electrode assembly of claim 10, wherein the first length is about 90%, about 80%, about 70%, about 60%, about 50%, about 40%, about 30%, about 20%, about 15%, about 10%, or about 5% shorter than the second length.

12. The electrode assembly of claim 10, wherein the anode current collector is formed from a material selected from the group consisting of titanium, nickel, copper and alloys thereof.

13. The electrode assembly of claim 10, wherein the cathode current collector is formed of titanium.

14. The electrode assembly of claim 10, wherein the cathode material comprises a solid reactive material, a binder material and a conductivity enhancer.

15. The electrode assembly of claim 10, wherein the solid reactive material is silver vanadium oxide.

16. The electrode assembly of claim 10, wherein the binder material is PTFE.

17. The electrode assembly of claim 10, wherein the conductivity enhancer is conductive carbon.

18. The electrode assembly of claim 10, wherein the separator covers the anode assembly and provides a seal therearound, the pouch having an opening through which the at least first connector tab projects.

19. An electrode assembly for an electrochemical cell, comprising:

(a) an anode assembly comprising an elongated strip of alkali metal forming an anode and an anode current collector having at least a first connector tab disposed on a first edge thereof, the strip of elongated alkali metal having a first length and a first height, the anode current collector having a second length and a second height;

(b) a cathode assembly, comprising:

(1) a cathode current collector having disposed on a second edge thereof at least a second connector tab, the cathode current collector having a third length and a third height; and

(2) a cathode material bonded to the current collector, the anode and cathode assemblies forming a unidirectional electrode winding having two substantially straight sides, the assemblies having interposed therebetween at least one separator, the first length of the anode current collector being shorter than the third length of the cathode current collector.

20. The electrode assembly of claim 19, wherein the first length is about 90%, about 80%, about 70%, about 60%, about 50%, about 40%, about 30%, about 20%, about 15%, about 10%, or about 5% shorter than the third length.

21. The electrode assembly of claim 19, wherein the anode current collector is formed from a material selected from the group consisting of titanium, nickel, copper and alloys thereof.

22. The electrode assembly of claim 19, wherein the cathode current collector is formed of titanium.

23. The electrode assembly of claim 19, wherein the cathode material comprises a solid reactive material, a binder material and a conductivity enhancer.

24. The electrode assembly of claim 19, wherein the solid reactive material is silver vanadium oxide.

25. The electrode assembly of claim 19, wherein the binder material is PTFE.

26. The electrode assembly of claim 19, wherein the conductivity enhancer is conductive carbon.

27. The electrode assembly of claim 19, wherein the separator covers the anode assembly and provides a seal therearound, the pouch having an opening through which the at least first connector tab projects.

28. An electrode assembly for an electrochemical cell, comprising:

(a) an anode assembly comprising an elongated strip of alkali metal forming an anode and an anode current collector having at least a first connector tab disposed on a first edge thereof, the strip of elongated alkali metal having a first length and a first height, the anode current collector having a second length and a second height;

(b) a cathode assembly, comprising:

(1) a cathode current collector having disposed on a second edge thereof at least a second connector tab, the cathode current collector having a third length and a third height; and

(2) a cathode material bonded to the current collector, the anode and cathode assemblies forming a unidirectional electrode winding having two substantially straight sides, the assemblies having interposed therebetween at least one separator, the first height of the anode current collector being shorter than the third height of the cathode current collector.

29. The electrode assembly of claim 28, wherein the first height is about 90%, about 80%, about 70%, about 60%, about 50%, about 40%, about 30%, about 20%, about 15%, about 10%, or about 5% shorter than the third height.

30. The electrode assembly of claim 28, wherein the anode current collector is formed from a material selected from the group consisting of titanium, nickel, copper and alloys thereof.

31. The electrode assembly of claim 28, wherein the cathode current collector is formed of titanium.

32. The electrode assembly of claim 28, wherein the cathode material comprises a solid reactive material, a binder material and a conductivity enhancer.

33. The electrode assembly of claim 28, wherein the solid reactive material is silver vanadium oxide.

34. The electrode assembly of claim 28, wherein the binder material is PTFE.

35. The electrode assembly of claim 28, wherein the conductivity enhancer is conductive carbon.

36. The electrode assembly of claim 28, wherein the separator covers the anode assembly and provides a seal therearound, the pouch having an opening through which the at least first connector tab projects.

37. An electrode assembly for an electrochemical cell, comprising:

(a) an anode assembly comprising an elongated strip of alkali metal forming an anode and an anode current collector having at least a first connector tab disposed on a first edge thereof, the strip of elongated alkali metal having a first length and a first height, the anode current collector having a second length and a second height;

(b) a cathode assembly, comprising:

(1) a cathode current collector having disposed on a second edge thereof at least a second connector tab, the cathode current collector having a third length and a third height; and

(2) a cathode material bonded to the current collector, the anode and cathode assemblies forming a unidirectional electrode winding having two substantially straight sides, the assemblies having interposed therebetween at least one separator, the first length of the anode current collector being shorter than the second length of the elongated strip of alkali metal, the first height of the anode current collector being shorter than the second height of the elongated strip of alkali metal.

38. The electrode assembly of claim 37, wherein the first height is about 90%, about 80%, about 70%, about 60%, about 50%, about 40%, about 30%, about 20%, about 15%, about 10%, or about 5% shorter than the second height.

39. The electrode assembly of claim 37, wherein the anode current collector is formed from a material selected from the group consisting of titanium, nickel, copper and alloys thereof.

40. The electrode assembly of claim 37, wherein the cathode current collector is formed of titanium.

41. The electrode assembly of claim 37, wherein the cathode material comprises a solid reactive material, a binder material and a conductivity enhancer.

42. The electrode assembly of claim 37, wherein the solid reactive material is silver vanadium oxide.

43. The electrode assembly of claim 37, wherein the binder material is PTFE.

44. The electrode assembly of claim 37, wherein the conductivity enhancer is conductive carbon.

45. The electrode assembly of claim 37, wherein the separator covers the anode assembly and provides a seal therearound, the pouch having an opening through which the at least first connector tab projects.

46. An electrode assembly for an electrochemical cell, comprising:

- (a) an anode assembly comprising an elongated strip of alkali metal forming an anode and an anode current collector having at least a first connector tab disposed on a first edge thereof, the strip of elongated alkali metal having a first length and a first height, the anode current collector having a second length and a second height;

(b) a cathode assembly, comprising:

- (1) a cathode current collector having disposed on a second edge thereof at least a second connector tab, the cathode current collector having a third length and a third height; and
- (2) a cathode material bonded to the current collector, the anode and cathode assemblies forming a unidirectional electrode winding having two substantially straight sides, the assemblies having interposed therebetween at least one separator, the first length of the anode current collector being shorter than the second length of the elongated strip of alkali metal, the first length of the anode current collector being shorter than the third length of the cathode current collector.

47. The electrode assembly of claim 46, wherein the first length is about 90%, about 80%, about 70%, about 60%, about 50%, about 40%, about 30%, about 20%, about 15%, about 10%, or about 5% shorter than the third length.

48. The electrode assembly of claim 46, wherein the anode current collector is formed from a material selected from the group consisting of titanium, nickel, copper and alloys thereof.

49. The electrode assembly of claim 46, wherein the cathode current collector is formed of titanium.

50. The electrode assembly of claim 46, wherein the cathode material comprises a solid reactive material, a binder material and a conductivity enhancer.

51. The electrode assembly of claim 46, wherein the solid reactive material is silver vanadium oxide.

52. The electrode assembly of claim 46, wherein the binder material is PTFE.

53. The electrode assembly of claim 46, wherein the conductivity enhancer is conductive carbon.

54. The electrode assembly of claim 46, wherein the separator covers the anode assembly and provides a seal therearound, the pouch having an opening through which the at least first connector tab projects.

55. An electrode assembly for an electrochemical cell, comprising:

- (a) an anode assembly comprising an elongated strip of alkali metal forming an anode and an anode current collector having at least a first connector tab disposed on a first edge thereof, the strip of elongated alkali metal having a first length and a first height, the anode current collector having a second length and a second height;

(b) a cathode assembly, comprising:

- (1) a cathode current collector having disposed on a second edge thereof at least a second connector tab, the cathode current collector having a third length and a third height; and
- (2) a cathode material bonded to the current collector, the anode and cathode assemblies forming a unidirectional electrode winding having two substantially straight sides, the assemblies having interposed therebetween at least one separator, the first length of the anode current collector being shorter than the second length of the elongated strip of alkali metal, the first height of the anode current collector being shorter than the third height of the cathode current collector.

56. The electrode assembly of claim 55, wherein the first length is about 90%, about 80%, about 70%, about 60%, about 50%, about 40%, about 30%, about 20%, about 15%, about 10%, or about 5% shorter than the second length.

57. The electrode assembly of claim 55, wherein the anode current collector is formed from a material selected from the group consisting of titanium, nickel, copper and alloys thereof.

58. The electrode assembly of claim 55, wherein the cathode current collector is formed of titanium.

59. The electrode assembly of claim 55, wherein the cathode material comprises a solid reactive material, a binder material and a conductivity enhancer.

60. The electrode assembly of claim 55, wherein the solid reactive material is silver vanadium oxide.

61. The electrode assembly of claim 55, wherein the binder material is PTFE.

62. The electrode assembly of claim 55, wherein the first height is about 90%, about 80%, about 70%, about 60%, about 50%, about 40%, about 30%, about 20%, about 15%, about 10%, or about 5% shorter than the third height.

63. The electrode assembly of claim 55, wherein the separator covers the anode assembly and provides a seal therearound, the pouch having an opening through which the at least first connector tab projects.

64. An electrode assembly for an electrochemical cell, comprising:

- (a) an anode assembly comprising an elongated strip of alkali metal forming an anode and an anode current collector having at least a first connector tab disposed on a first edge thereof, the strip of elongated alkali

metal having a first length and a first height, the anode current collector having a second length and a second height;

(b) a cathode assembly, comprising:

(1) a cathode current collector having disposed on a second edge thereof at least a second connector tab, the cathode current collector having a third length and a third height; and

(2) a cathode material bonded to the current collector, the anode and cathode assemblies forming a unidirectional electrode winding having two substantially straight sides, the assemblies having interposed therebetween at least one separator, the first height of the anode current collector being shorter than the second height of the elongated strip of alkali metal, the first length of the anode current collector being shorter than the third length of the cathode current collector.

65. The electrode assembly of claim 64, wherein the first length is about 90%, about 80%, about 70%, about 60%, about 50%, about 40%, about 30%, about 20%, about 15%, about 10%, or about 5% shorter than the third length.

66. The electrode assembly of claim 64, wherein the anode current collector is formed from a material selected from the group consisting of titanium, nickel, copper and alloys thereof.

67. The electrode assembly of claim 64, wherein the cathode current collector is formed of titanium.

68. The electrode assembly of claim 64, wherein the cathode material comprises a solid reactive material, a binder material and a conductivity enhancer.

69. The electrode assembly of claim 64, wherein the solid reactive material is silver vanadium oxide.

70. The electrode assembly of claim 64, wherein the first height is about 90%, about 80%, about 70%, about 60%, about 50%, about 40%, about 30%, about 20%, about 15%, about 10%, or about 5% shorter than the second height.

71. The electrode assembly of claim 64, wherein the conductivity enhancer is conductive carbon.

72. The electrode assembly of claim 64, wherein the separator covers the anode assembly and provides a seal therearound, the pouch having an opening through which the at least first connector tab projects.

73. An electrode assembly for an electrochemical cell, comprising:

(a) an anode assembly comprising an elongated strip of alkali metal forming an anode and an anode current collector having at least a first connector tab disposed on a first edge thereof, the strip of elongated alkali metal having a first length and a first height, the anode current collector having a second length and a second height;

(b) a cathode assembly, comprising:

(1) a cathode current collector having disposed on a second edge thereof at least a second connector tab, the cathode current collector having a third length and a third height; and

(2) a cathode material bonded to the current collector, the anode and cathode assemblies forming a unidirectional electrode winding having two substantially straight sides, the assemblies having interposed therebetween at least one separator, the first height of the

anode current collector being shorter than the second height of the elongated strip of alkali metal, the first length of the anode current collector being shorter than the third length of the cathode current collector, the first height of the anode current collector being shorter than the third height of the cathode current collector.

74. The electrode assembly of claim 73, wherein the first length is about 90%, about 80%, about 70%, about 60%, about 50%, about 40%, about 30%, about 20%, about 15%, about 10%, or about 5% shorter than the third length.

75. The electrode assembly of claim 73, wherein the anode current collector is formed from a material selected from the group consisting of titanium, nickel, copper and alloys thereof.

76. The electrode assembly of claim 73, wherein the cathode current collector is formed of titanium.

77. The electrode assembly of claim 73, wherein the cathode material comprises a solid reactive material, a binder material and a conductivity enhancer.

78. The electrode assembly of claim 73, wherein the solid reactive material is silver vanadium oxide.

79. The electrode assembly of claim 73, wherein the first height is about 90%, about 80%, about 70%, about 60%, about 50%, about 40%, about 30%, about 20%, about 15%, about 10%, or about 5% shorter than the third height.

80. The electrode assembly of claim 73, wherein the conductivity enhancer is conductive carbon.

81. The electrode assembly of claim 73, wherein the separator covers the anode assembly and provides a seal therearound, the pouch having an opening through which the at least first connector tab projects.

82. An electrode assembly for an electrochemical cell, comprising:

(a) an anode assembly comprising an elongated strip of alkali metal forming an anode and an anode current collector having at least a first connector tab disposed on a first edge thereof, the strip of elongated alkali metal having a first length and a first height, the anode current collector having a second length and a second height;

(b) a cathode assembly, comprising:

(1) a cathode current collector having disposed on a second edge thereof at least a second connector tab, the cathode current collector having a third length and a third height; and

(2) a cathode material bonded to the current collector, the anode and cathode assemblies forming a unidirectional electrode winding having two substantially straight sides, the assemblies having interposed therebetween at least one separator, the first length of the anode current collector being shorter than the third length of the cathode current collector, the first height of the anode current collector being shorter than the third height of the cathode current collector.

83. The electrode assembly of claim 82, wherein the first length is about 90%, about 80%, about 70%, about 60%, about 50%, about 40%, about 30%, about 20%, about 15%, about 10%, or about 5% shorter than the third length.

84. The electrode assembly of claim 82, wherein the anode current collector is formed from a material selected

from the group consisting of titanium, nickel, copper and alloys thereof.

85. The electrode assembly of claim 82, wherein the cathode current collector is formed of titanium.

86. The electrode assembly of claim 82, wherein the cathode material comprises a solid reactive material, a binder material and a conductivity enhancer.

87. The electrode assembly of claim 82, wherein the solid reactive material is silver vanadium oxide.

88. The electrode assembly of claim 82, wherein the first height is about 90%, about 80%, about 70%, about 60%,

about 50%, about 40%, about 30%, about 20%, about 15%, about 10%, or about 5% shorter than the third height.

89. The electrode assembly of claim 82, wherein the conductivity enhancer is conductive carbon.

90. The electrode assembly of claim 82, wherein the separator covers the anode assembly and provides a seal therearound, the pouch having an opening through which the at least first connector tab projects.

* * * * *